

ULINE H-2564

8' A-FRAME PICNIC TABLE

1-800-295-5510
uline.com

TOOLS NEEDED



Power Drill or
Impact Driver



7/16" (11 mm)
Socket Bit

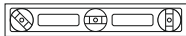

Level



Two Person Assembly
Recommended

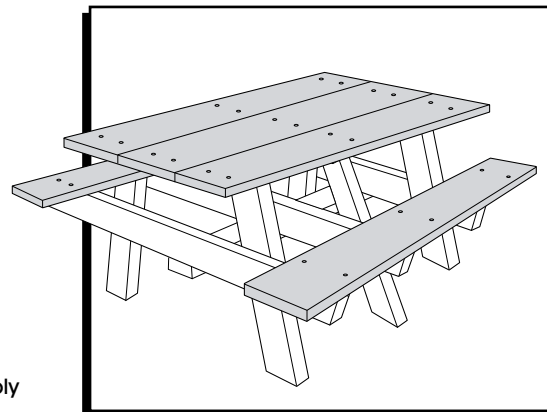

PARTS

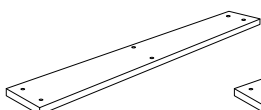

Seat Board x 2

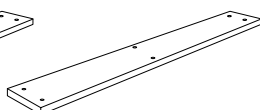

Tabletop Board x 3

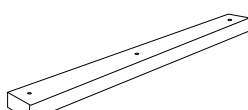

Leg Brace Board x 1

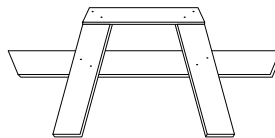

A-Frame Base x 3

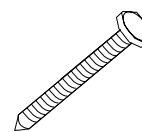

3/2" Lag Screw x 33



Washer x 33

ASSEMBLY



NOTE: It is important to keep the lag screws loose throughout assembly. Tighten during step 6.



WARNING! Do not lean on tabletop or seats when assembling.

1. Verify all parts are present before beginning.
2. Place the three A-Frame bases on a flat, level surface.
3. Place one seat board on each side of the A-Frame bases. Align the pre-drilled holes over the middle of the A-Frame base supports. Seat board should be flush with the end of support.
4. Loosely attach seat boards to A-Frame base with 3/2" lag screws and washers using the power drill and 7/16" socket bit (will tighten later in step 6). (See Figure 1)

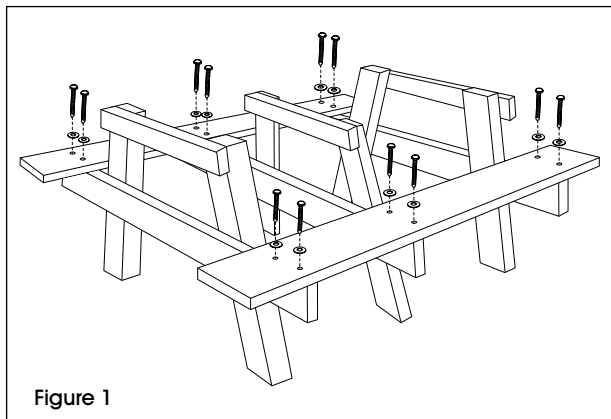

Figure 1

5. Place the three tabletop boards on the A-Frame bases. Align the pre-drilled holes with the A-Frame base. Loosely attach tabletop board slats to A-Frame base with the 3/2" lag screws and washers using the power drill and 7/16" socket bit (will tighten later in step 6). (See Figure 2)
6. Make sure the table is square and tighten all lag screws.

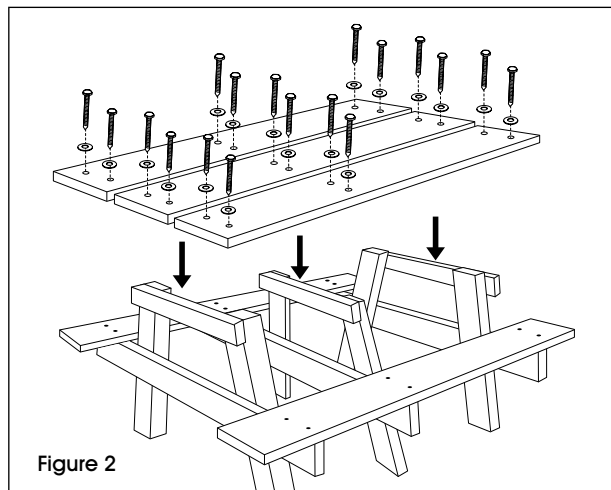
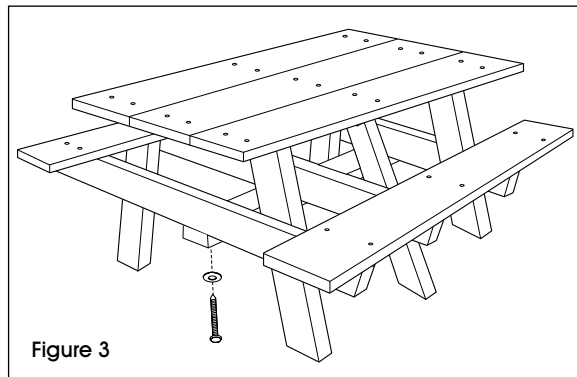

Figure 2

ASSEMBLY CONTINUED

7. Attach leg brace board to the underside of the A-Frame bases with the 3½" lag screws and washers using the power drill. (See Figure 3)

 **NOTE: H-6681 mounting hardware sold separately. Two packs are recommended.**



ULINE

1-800-295-5510
uline.com

ULINE H-2564

MESA CON ARMAZÓN EN A PARA PÍCNIC – 8'

HERRAMIENTAS NECESARIAS



Taladro Eléctrico
o Atornillador de
Impacto



Dado de 11
mm (7/16")



Nivel

800-295-5510

uline.mx



Se recomienda Armar
Entre Dos Personas

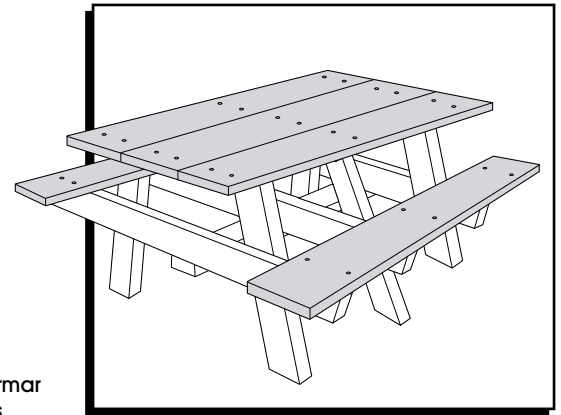

PARTES

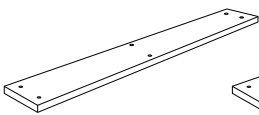

2 Tablas para
Asiento

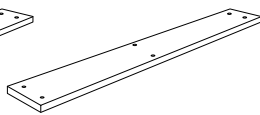

3 Tablas para
Cubierta

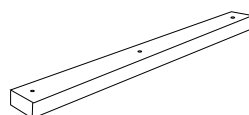

1 Tabla de Soporte
para Patas

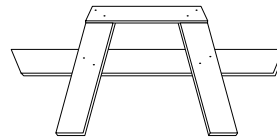

3 Bases del
Armadón en A

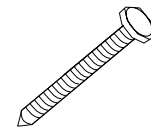

33 Tornillos Tirafondo
de 3/2"



33 Rondanas

ENSAMBLE



NOTA: Es importante mantener los tornillos aflojados durante el ensamble. Apriételes hasta el paso 6.



¡ADVERTENCIA! No se recargue sobre la cubierta o asientos mientras está ensamblando.

1. Verifique que estén todas las partes antes de comenzar.
2. Coloque las tres bases del Armazón en A sobre una superficie plana y nivelada.
3. Coloque una tabla para asiento a cada lado de las bases del Armazón en A. Alinee los orificios preperforados por el medio de los soportes de los Armazones en A. La tabla para asiento deberá quedar alineada con el extremo del soporte.
4. Acople ligeramente las tablas para asientos a las bases del Armazón en A con tornillos tirafondo de 3/2" y las rondanas utilizando el taladro y el dado de 7/16" (después se apretarán en el paso 6). (Vea Diagrama 1)



Diagrama 1

5. Coloque las tres tablas de la cubierta en las bases del Armazón en A. Alinee los orificios preperforados con la base del Armazón en A. Acople ligeramente las ranuras de las tablas para cubierta a las bases del Armazón en A con los tornillos tirafondo de 3/2" y las rondanas utilizando el taladro eléctrico y el dado de 7/16" (después se apretarán en el paso 6). (Vea Diagrama 2)
6. Asegúrese de que la mesa esté en escuadra y apriete todos los tornillos tirafondo.

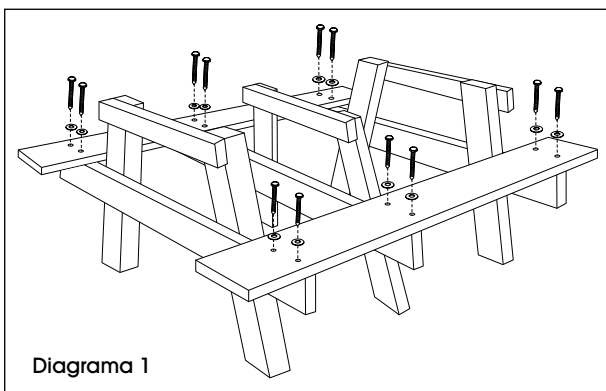

Diagrama 2

CONTINUACIÓN DE ENSAMBLE

7. Fije la tabla de soporte de las patas por debajo de las bases del Armazón en A con los tornillos tirafondo de 3½" y las rondanas utilizando el taladro eléctrico. (Vea Diagrama 3)

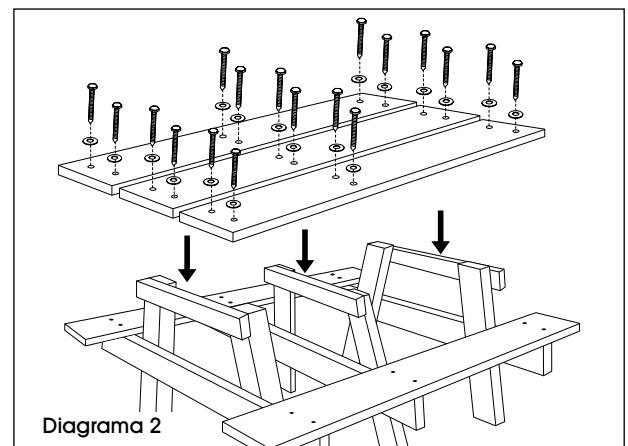

NOTA: La tornillería de instalación H-6681 se vende por separado. Se recomiendan dos paquetes.



Diagrama 3

ULINE

800-295-5510
uline.mx

ULINE H-2564

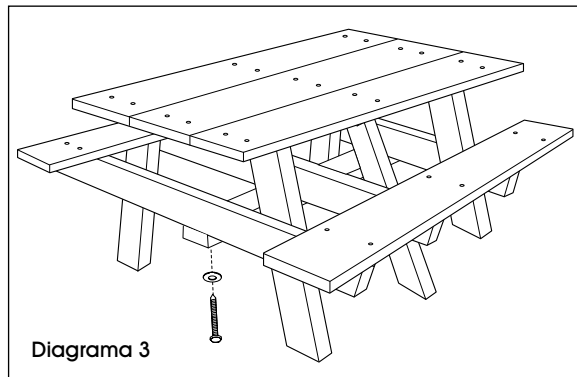
1-800-295-5510

uline.ca

TABLE DE PIQUE-NIQUE EN A – 8 pi

OUTILS REQUIS



Perceuse électrique
ou visseuse à
percussion



Douille tournevis
de 11 mm (7/16 po)



Niveau à bulle



Montage à deux
personnes recommandé

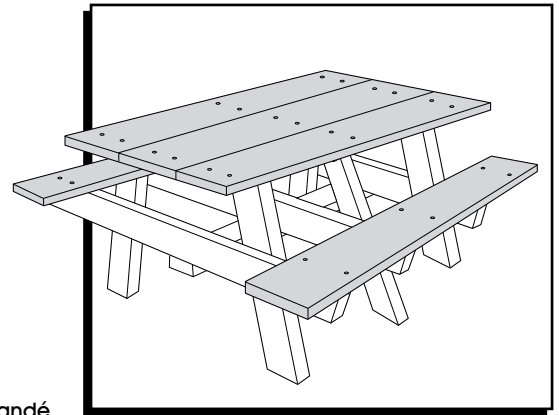

PIÈCES



Planche de
siège x 2



Planche du dessus
de table x 3

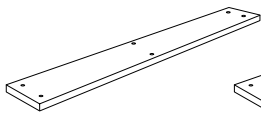

Renfort de pied x 1

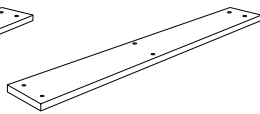
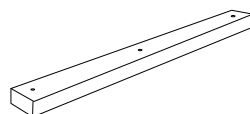
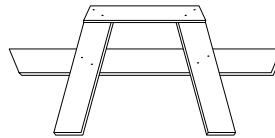

Base en forme
de A x 3

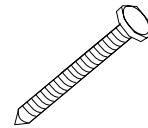

Tire-fond de
3 1/2 po x 33



Rondelle x 33

MONTAGE



REMARQUE : Il est important de ne pas serrer les tire-fonds durant le montage. Le vissage s'effectue à l'étape 6.



AVERTISSEMENT! Ne vous appuyez pas sur la surface de table ou les sièges durant le montage.

1. Assurez-vous que toutes les pièces sont présentes avant de commencer.
2. Placez les bases en A sur une surface plane nivelée.
3. Placez une planche de siège de chaque côté des bases en A. Alignez les trous prépercés au-dessus du milieu des supports de base en A. Les planches de siège doivent s'aligner avec les extrémités du support.
4. Fixez sans serrer les planches de siège à la base en A à l'aide des tire-fonds de 3 1/2 po et des rondelles en utilisant la perceuse et la douille tournevis de 7/16 po (à bien visser plus tard à l'étape 6). (Voir Figure 1)

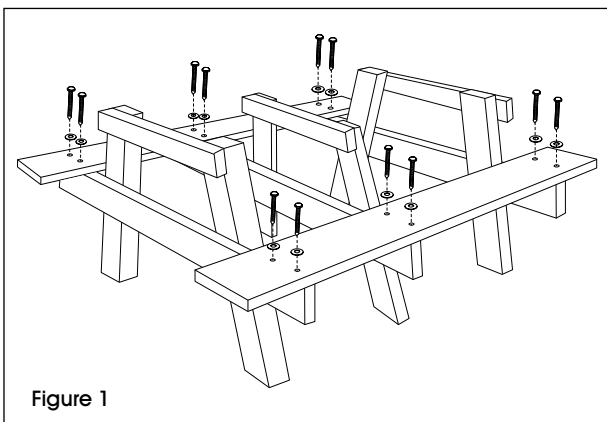

Figure 1

5. Placez les trois planches du dessus de table sur les bases en A. Alignez les trous prépercés sur la base en A. Fixez sans serrer les planches du dessus de table à la base en A à l'aide des tire-fonds de 3 1/2 po et des rondelles en utilisant la perceuse et la douille tournevis de 7/16 po (à bien visser plus tard à l'étape 6). (Voir Figure 2)
6. Assurez-vous que la table est bien cadrée et vissez tous les tire-fonds.

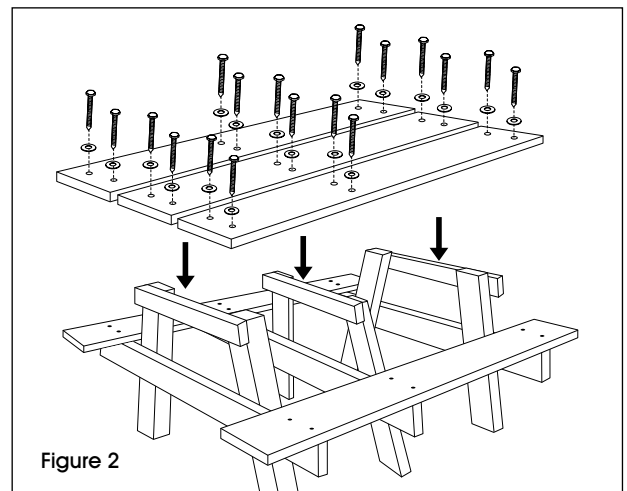

Figure 2

MONTAGE SUITE

7. À l'aide de la perceuse, fixez le renfort de pied sur la face inférieure des bases en A avec les tire-fonds de 3½ po et les rondelles. (Voir Figure 3)



REMARQUE : Le matériel d'installation H-6681 est vendu séparément. Deux sachets de matériel sont recommandés.

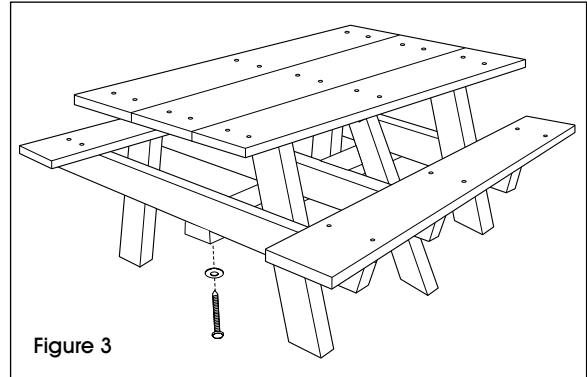

Figure 3

ULINE

1-800-295-5510
uline.ca