

ULINE H-2589 HIGHWAY WARNING TRIANGLE KIT

1-800-295-5510
uline.com

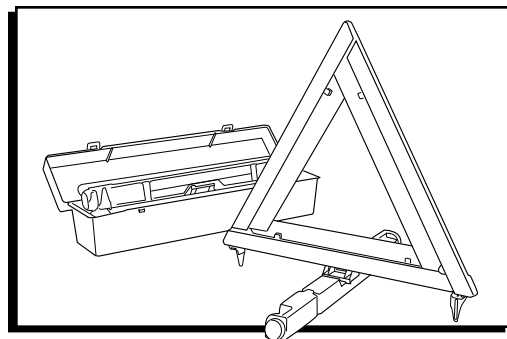

ASSEMBLY

 **NOTE:** Before leaving your vehicle, turn on emergency flashers.

1. Raise the two arms. (See Figures 1-2)

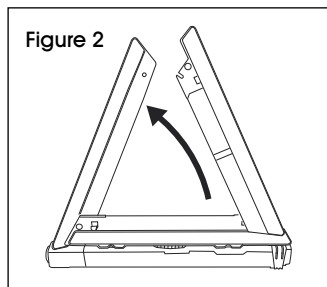
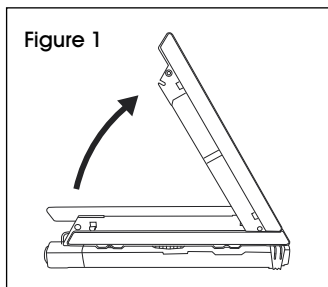

2. Snap pin into slot at the top of the arms to connect. (See Figure 3)

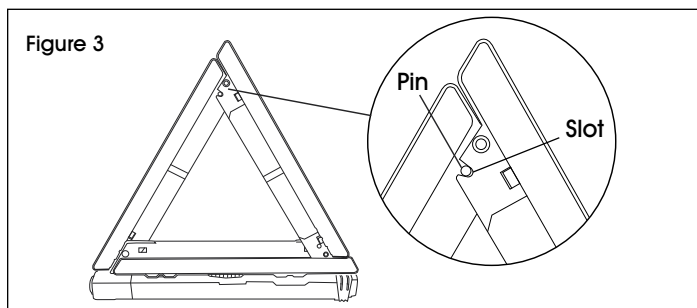

3. Turn the triangle 90° on top of the black base. (See Figure 4)

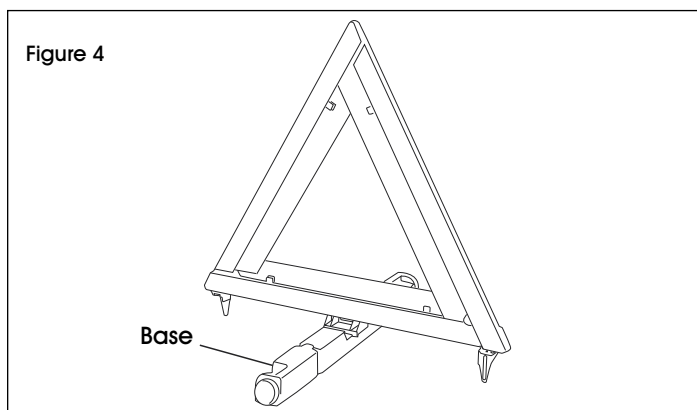

4. Insert wire into hole at the top of the triangle. (See Figure 5)

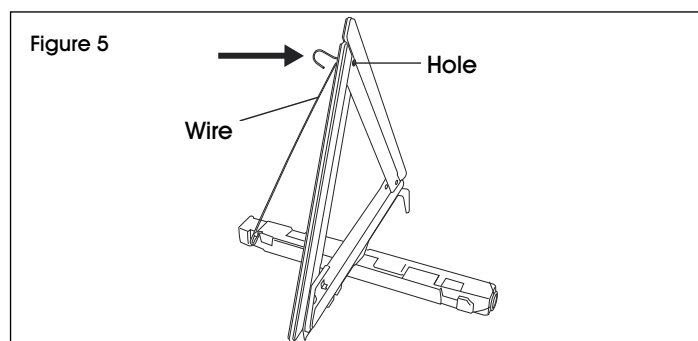

5. Set triangle(s) per diagram below, facing traffic. (See Figure 6)

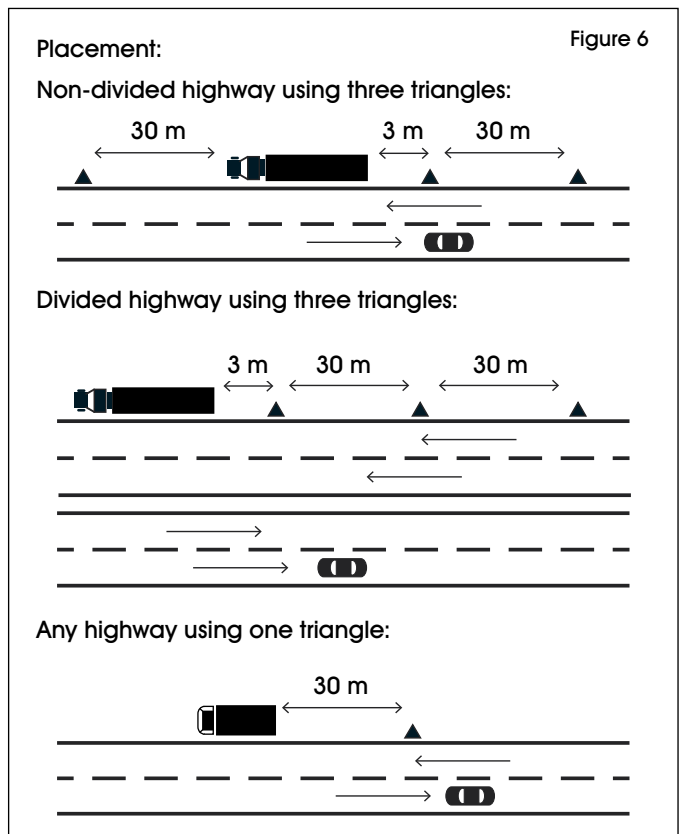

ULINE H-2589 KIT DE TRIÁNGULO DE EMERGENCIA PARA AUTOPISTAS

800-295-5510
uline.mx

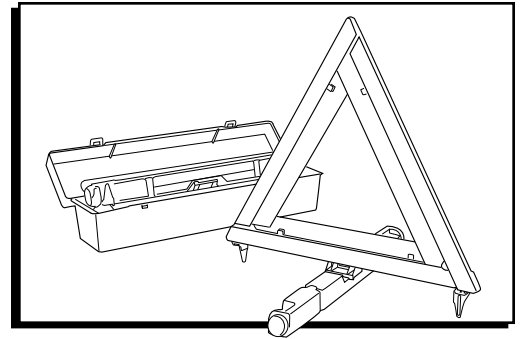

ENSAMBLE

NOTA: Antes de salir de su vehículo, encienda las intermitentes de emergencia.

1. Levante los dos brazos. (Vea Diagramas 1-2)

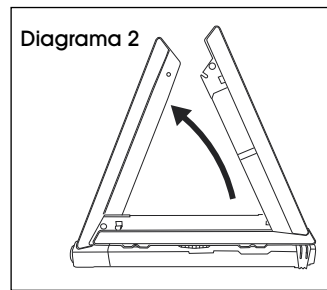
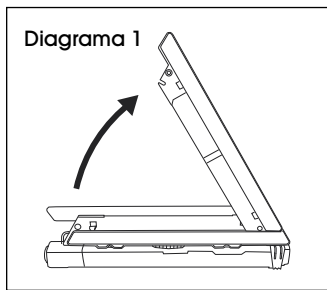

2. Inserte el pivote en la ranura de la parte superior de los brazos ejerciendo presión para unirlos. (Vea Diagrama 3)

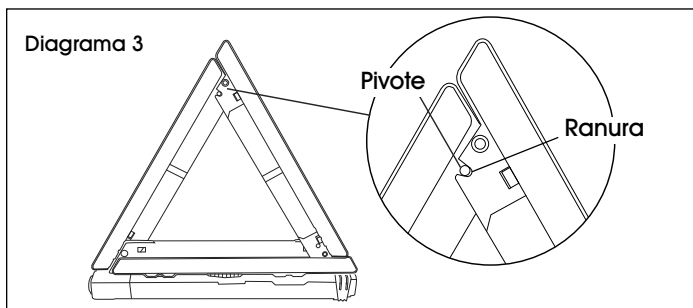

3. Gire el triángulo 90° con respecto a la base negra. (Vea Diagrama 4)

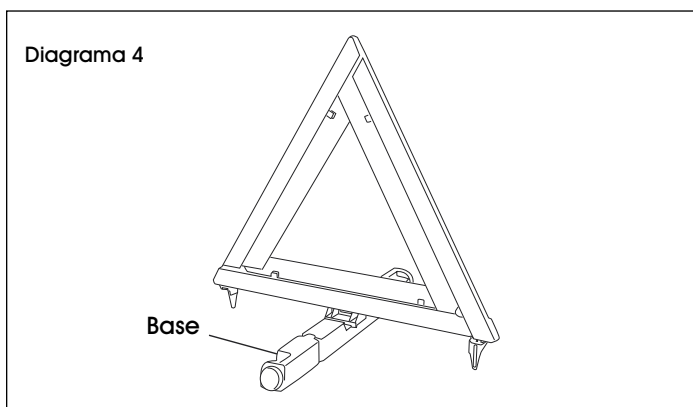

4. Inserte el alambre en el orificio de la parte superior del triángulo. (Vea Diagrama 5)

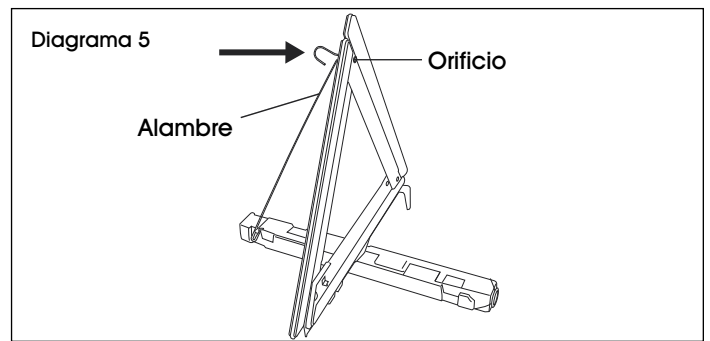

5. Coloque el/los triángulo(s) tal y como se muestra en el diagrama a continuación, mirando al tráfico. (Vea Diagrama 6)

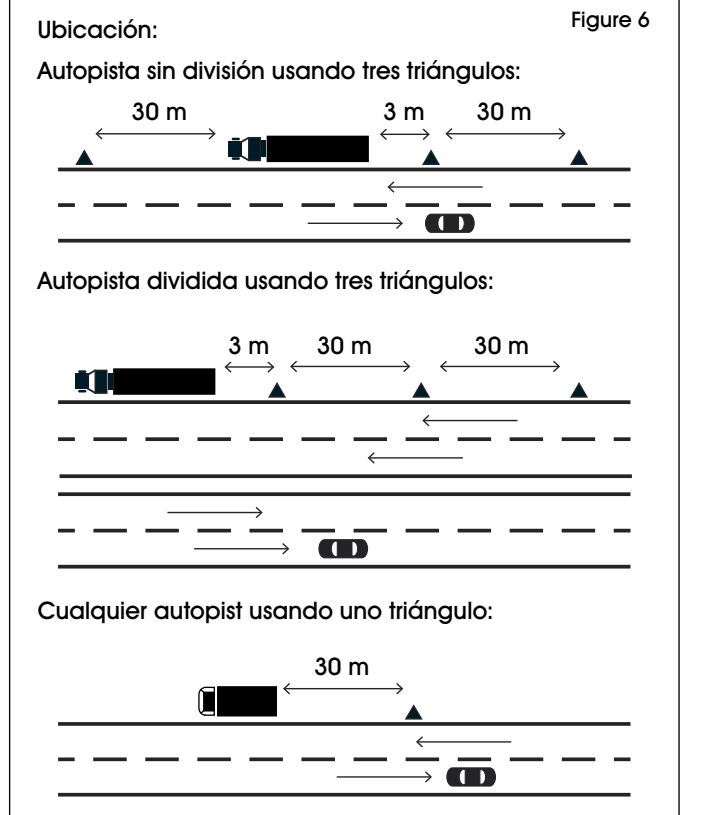

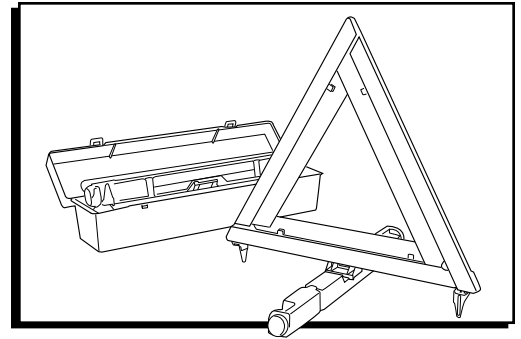

MONTAGE

REMARQUE : Avant de quitter votre véhicule, allumez les feux de détresse.

1. Levez les deux bras. (Voir Figures 1 et 2)

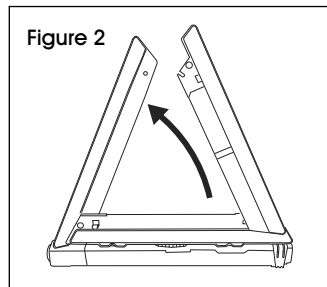
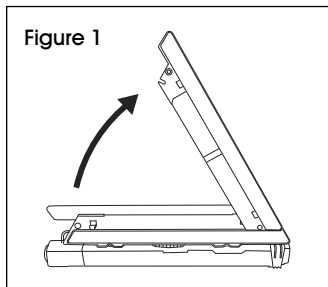

2. Encliquez la tige dans la fente de la partie supérieure des bras pour les raccorder. (Voir Figure 3)

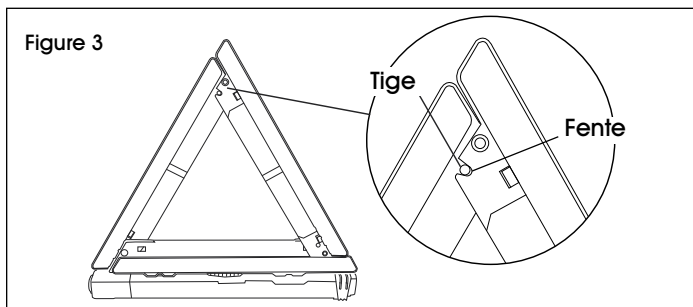

3. Tournez le triangle de 90° sur la base noire. (Voir Figure 4)

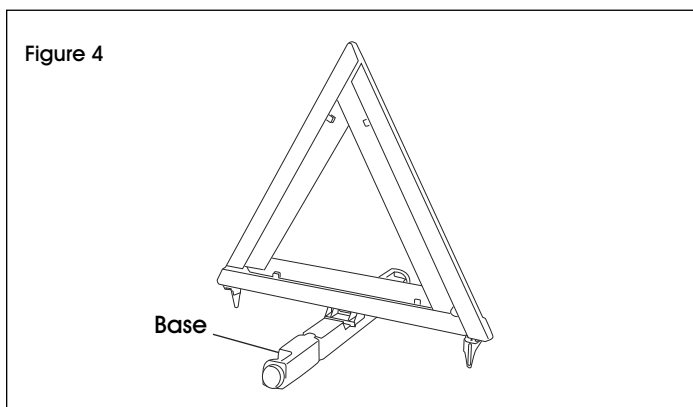

4. Insérez le fil dans le trou au sommet du triangle. (Voir Figure 5)

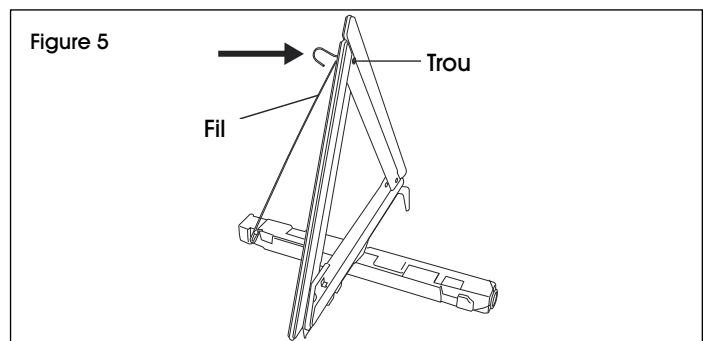

5. Réglez le(s) triangle(s) selon le schéma ci-dessous, en les plaçant face à la circulation. (Voir Figure 6)

