

ULINE H-2666, H-2667
H-6708, H-8154
**METAL PLATFORM
TRUCKS**

1-800-295-5510
uline.com

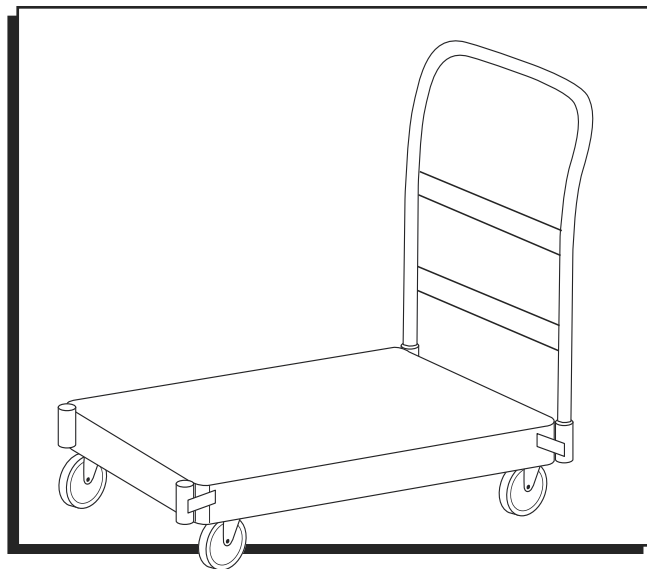

TOOLS NEEDED

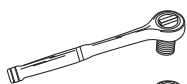

3/4" Socket Wrench

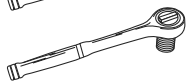

9/16" Socket Wrench

INSTRUCTIONS

1. Attach casters to deck using 9/16" bolts, lock washers and washers. (See Figure 1)
2. Flip the deck over. Insert handle into desired set of handle sockets. (See Figure 2)
3. Secure handle with washers, lock washers and 3/4" bolts. (See Figure 2)



NOTE: Make sure same set of casters go on each end of the deck.

Figure 1

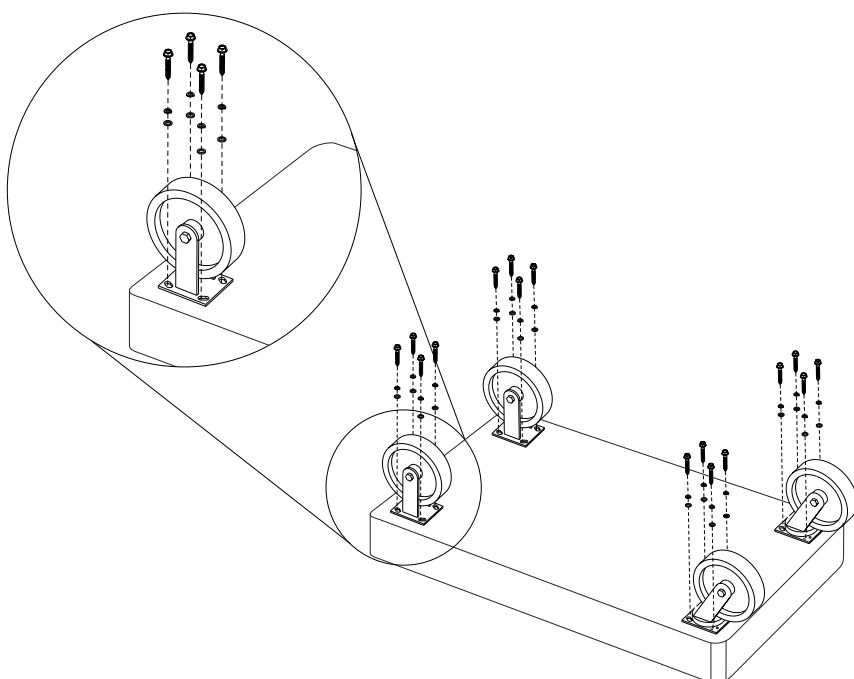
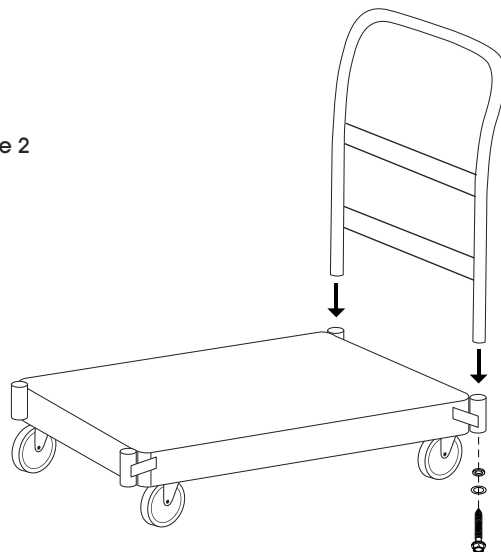
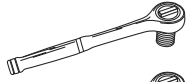

Figure 2



CARRITOS CON PLATAFORMA DE METAL

HERRAMIENTAS NECESARIAS



Llave de Dado de 3/4"

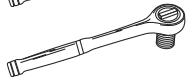

Llave de Dado de 9/16"

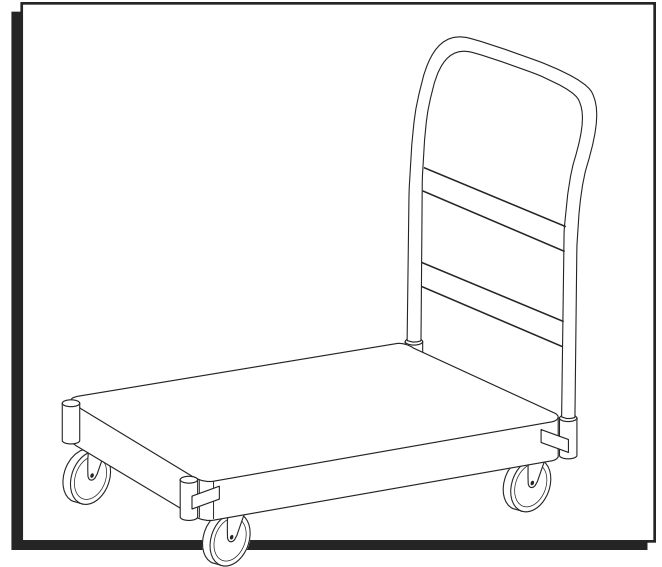

INSTRUCCIONES

1. Alinee las ruedas con la plataforma con pernos de 9/16", rondanas de seguridad y rondanas. (Vea Diagrama 1)

 **NOTA:** Asegúrese de colocar el mismo juego de ruedas en cada uno de los extremos de la plataforma.

2. Voltee la plataforma. Inserte el asa en los orificios de entrada para el asa. (Vea Diagrama 2)
3. Fije el asa con las rondanas, rondanas de seguridad y pernos de 3/4". (Vea Diagrama 2)

Diagrama 1



Diagrama 2



CHARIOT À PLATEFORME EN MÉTAL

OUTILS REQUIS

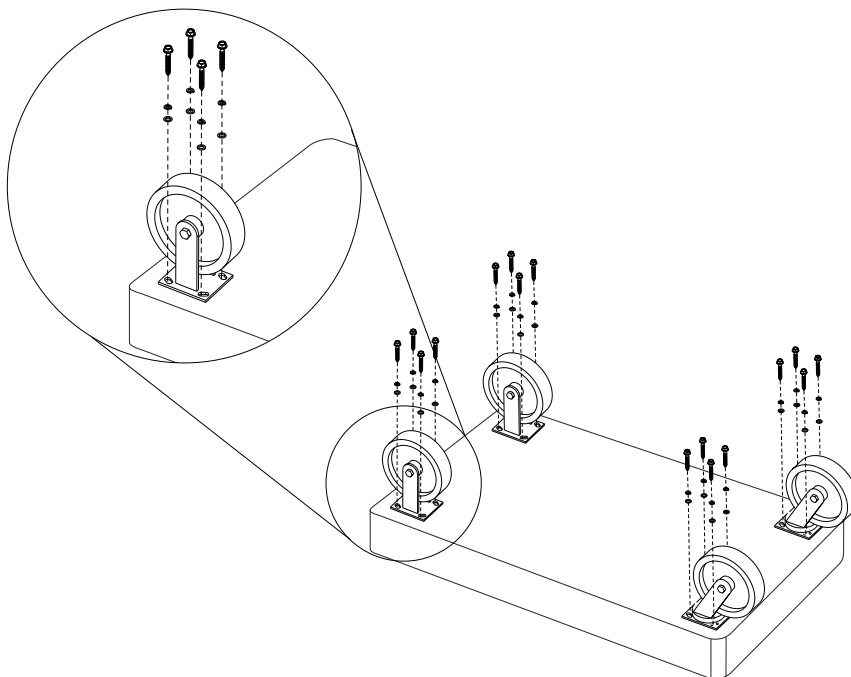
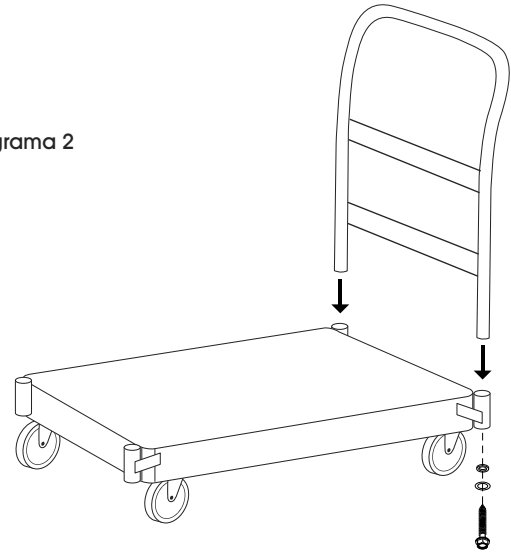
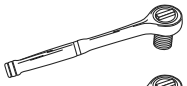

Clé à douilles de 3/4 po

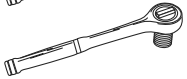

Clé à douilles de 9/16 po

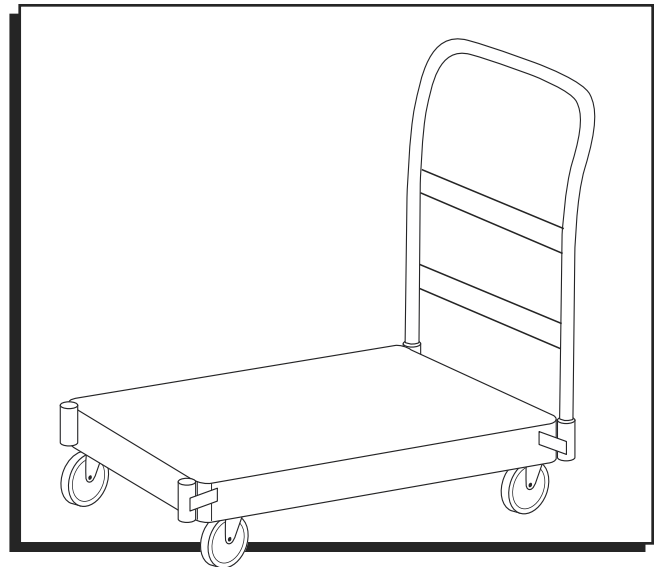

INSTRUCTIONS

1. Fixez les roulettes à la plateforme à l'aide des boulons de 9/16 po, des rondelles de blocage et des rondelles. (Voir Figure 1)



REMARQUE : Assurez-vous que le même ensemble de roulettes est installé à chaque extrémité de la plateforme.

2. Retournez la plateforme. Insérez la poignée dans l'ensemble d'emboîtures pour poignée souhaité. (Voir Figure 2)

3. Fixez la poignée à l'aide des rondelles, des rondelles de blocage et des boulons de 3/4 po. (Voir Figure 2)

Figure 1

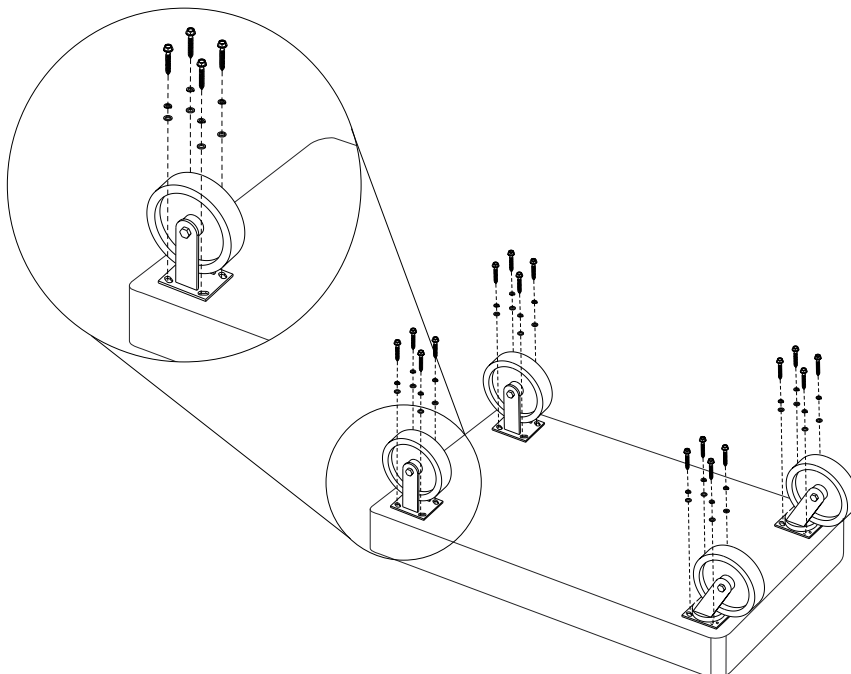

Figure 2

