

ULINE INDUSTRIAL STEEL SHELVING

1-800-295-5510
 uline.com

TOOLS NEEDED

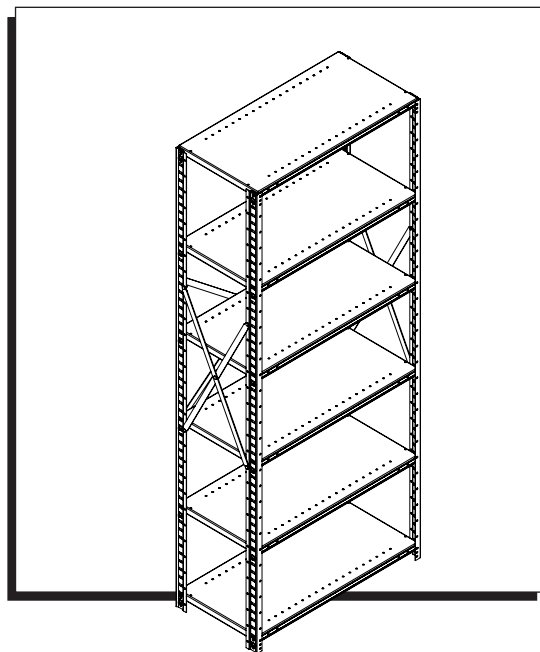

PARTS

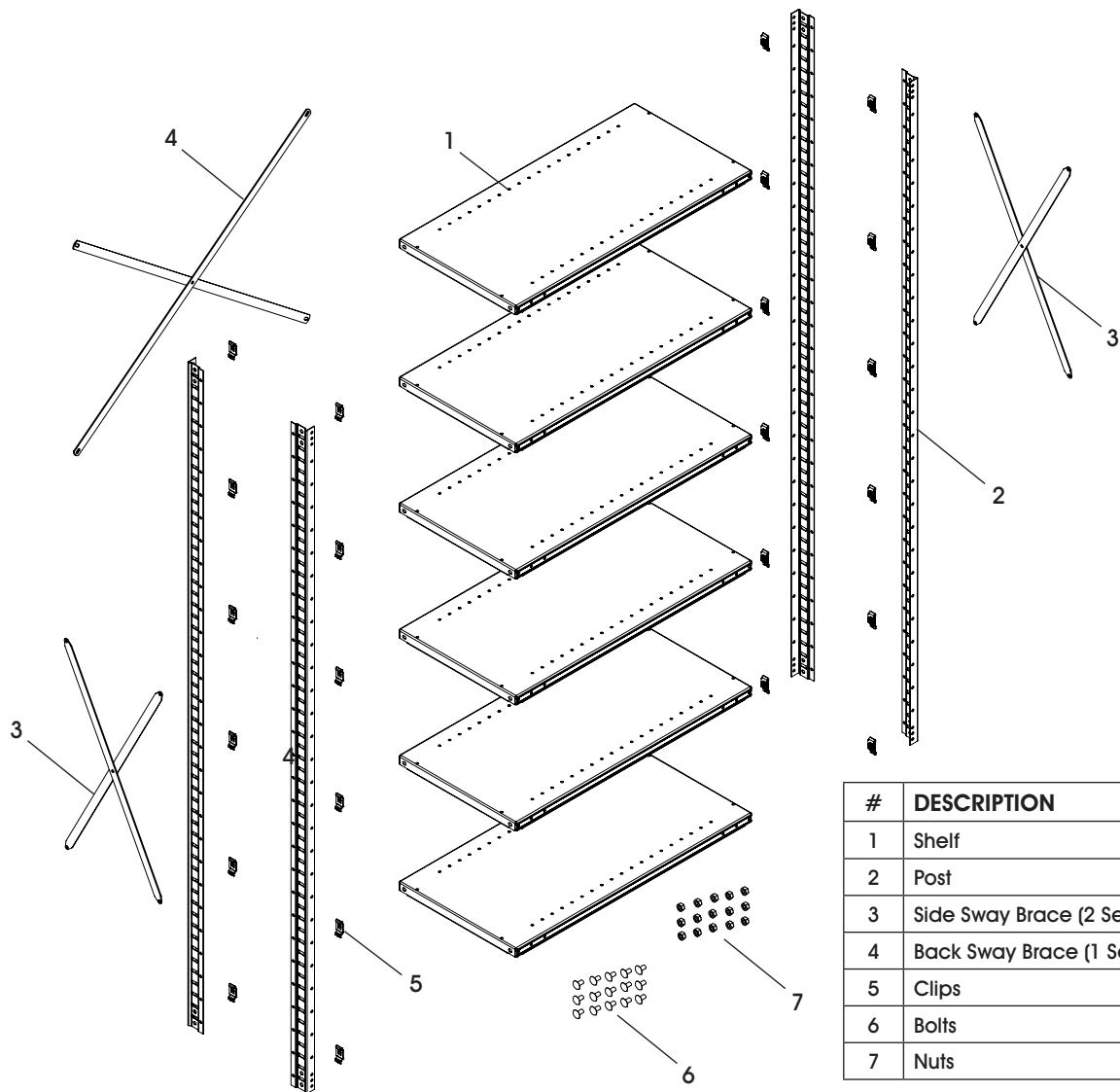

#	DESCRIPTION	QTY.
1	Shelf	6
2	Post	4
3	Side Sway Brace (2 Sets)	4
4	Back Sway Brace (1 Set)	2
5	Clips	24
6	Bolts	15
7	Nuts	15

INSTRUCTIONS

LEFT SIDE VIEW

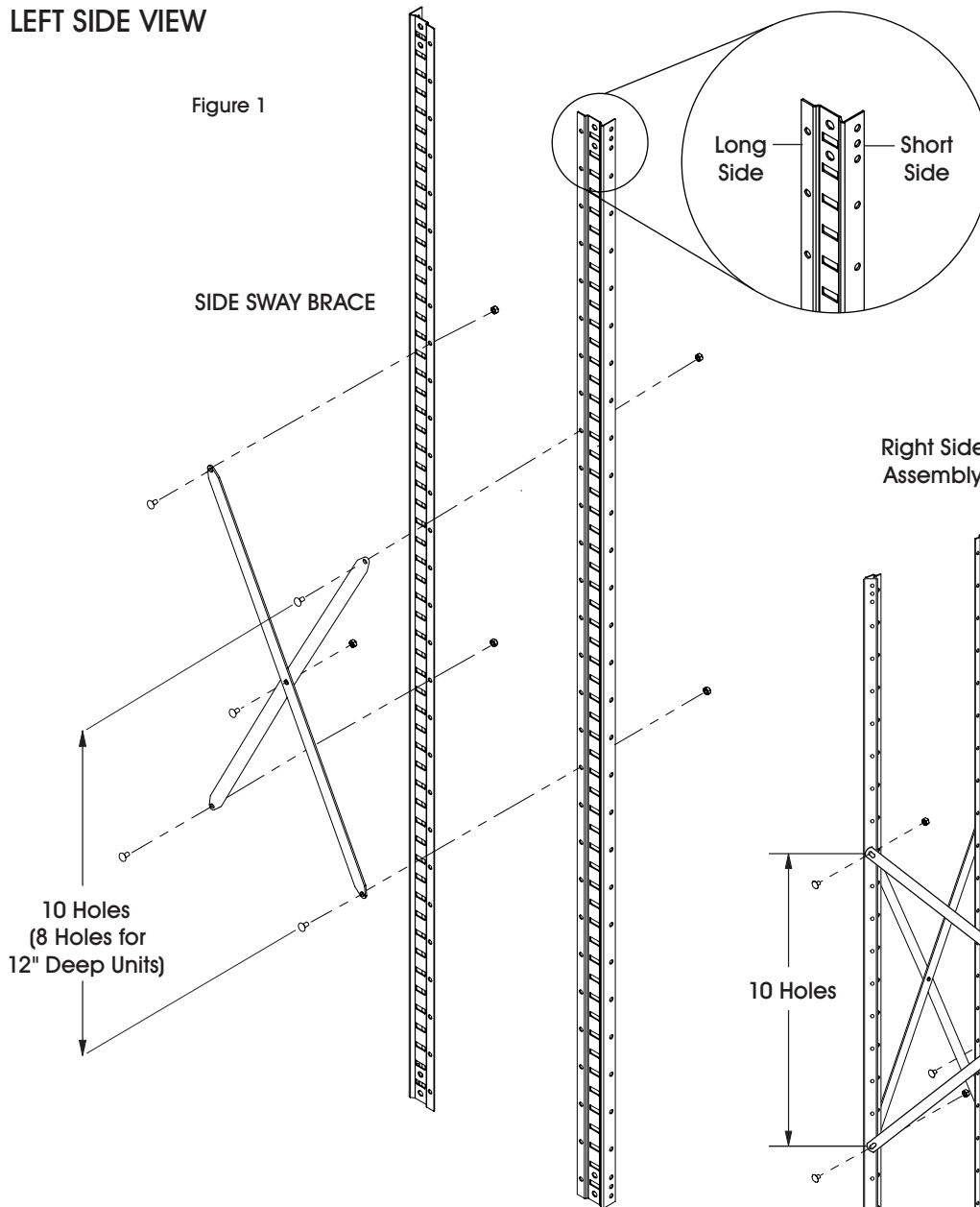

BACK VIEW

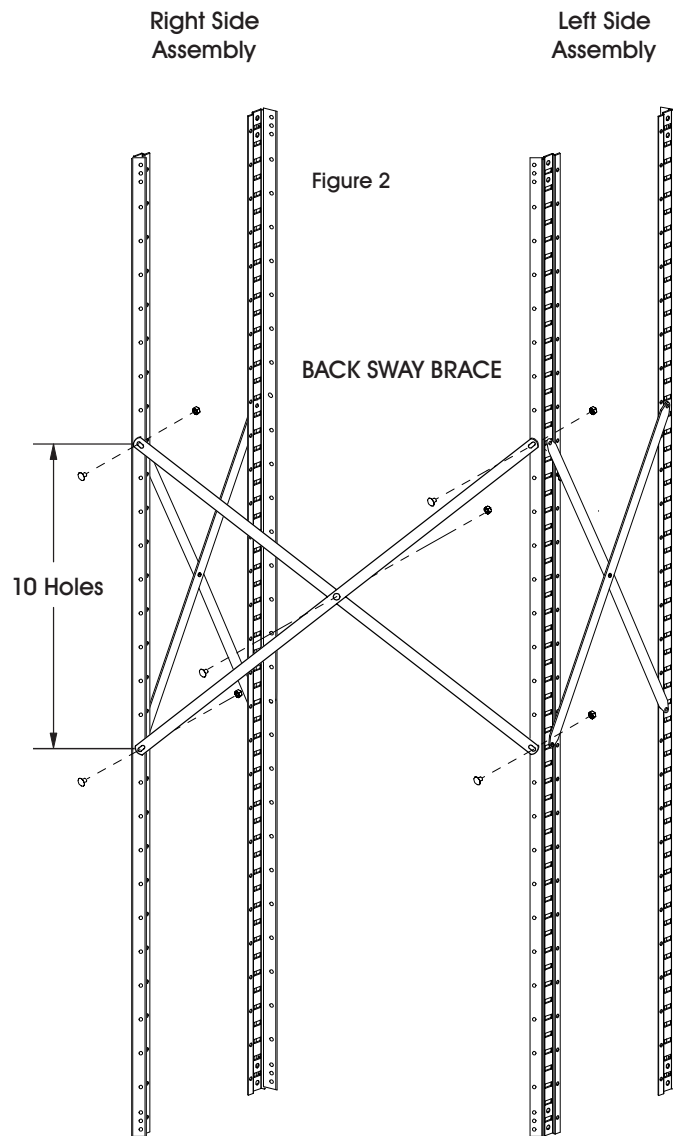

1. To assemble left side, center side sway braces and affix to posts. (See Figure 1)

 **NOTE:** Do not fully tighten nuts and bolts.

 **NOTE:** For 12" deep units (H-3841, H-3842, H-3843, H-3844), side sway braces must be 8 holes apart.

2. Assemble right side. Repeat steps from above.

1. To assemble back, center back sway brace and affix to posts. (See Figure 2)

INSTRUCTIONS CONTINUED

Figure 3

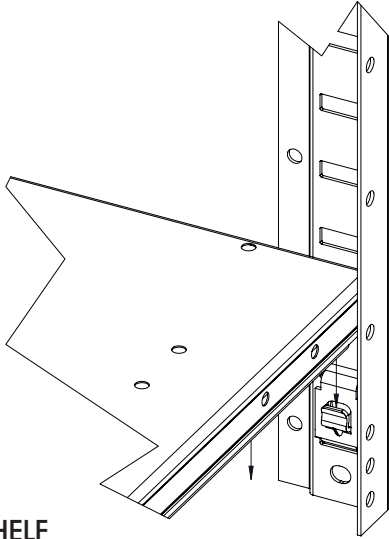

BOTTOM SHELF

1. Insert clips into the first two bottom slots of the posts.
2. Insert the shelf into the clips.

Figure 4

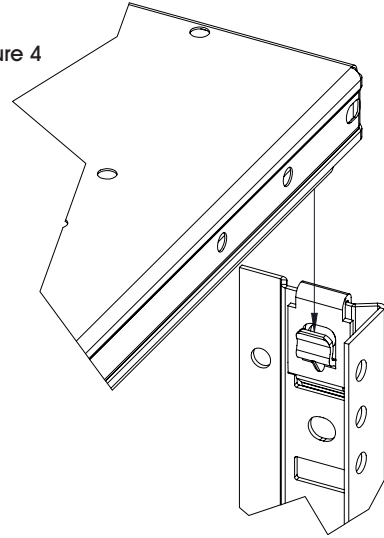

TOP SHELF

1. Insert clips into the top and last slot of the posts.
2. Insert the shelf into the clips.

Figure 5

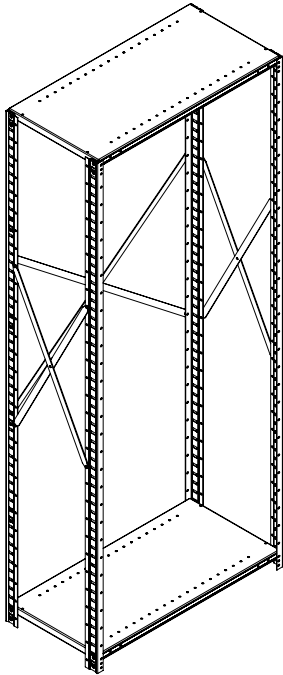

1. Make sure all bolts are fully tightened.

Figure 6

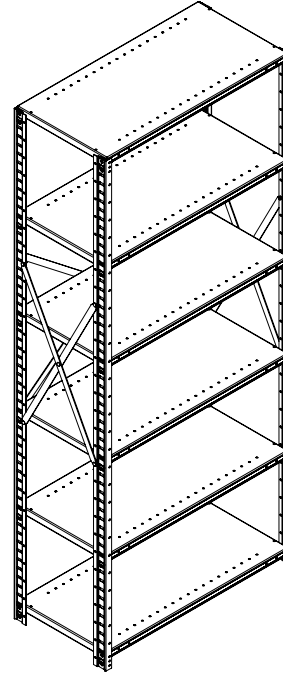

1. Insert remaining clips at desired shelf heights.
2. Insert remaining shelves into the clips.

ULINE

1-800-295-5510
uline.com

ULINE

ESTANTERÍA DE ACERO INDUSTRIAL

800-295-5510
uline.mx

HERRAMIENTAS NECESARIAS



Llave de 11 mm

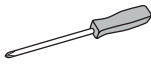

Desarmador de Cruz



Escalera (opcional)

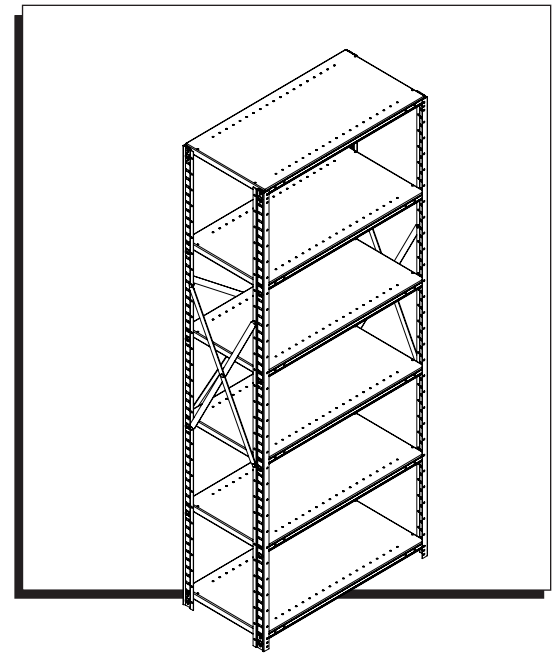

PARTES

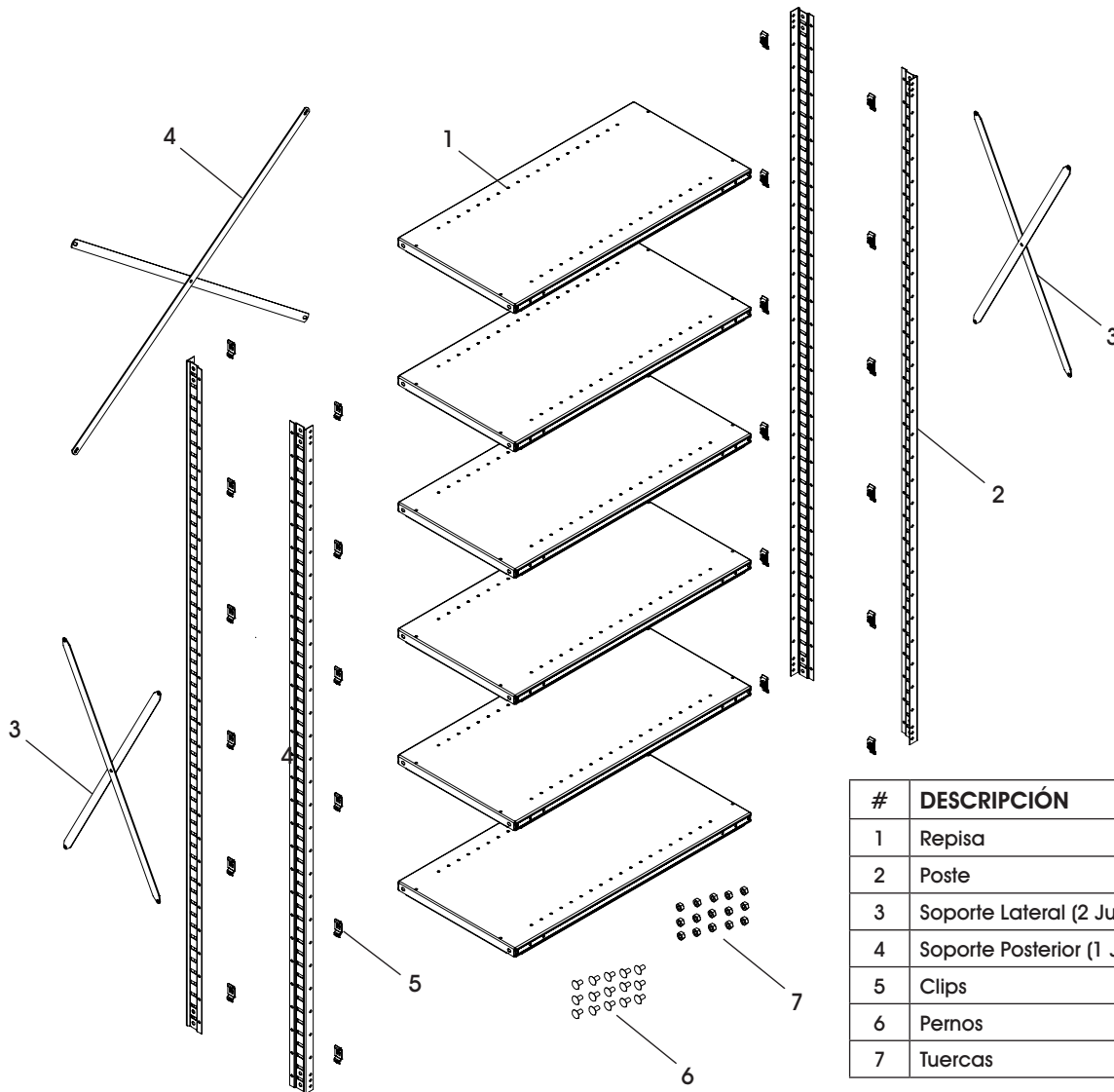

#	DESCRIPCIÓN	CANT.
1	Repisa	6
2	Poste	4
3	Soporte Lateral (2 Juegos)	4
4	Soporte Posterior (1 Juego)	2
5	Clips	24
6	Pernos	15
7	Tuercas	15

INSTRUCCIONES

VISTA LATERAL IZQUIERDA

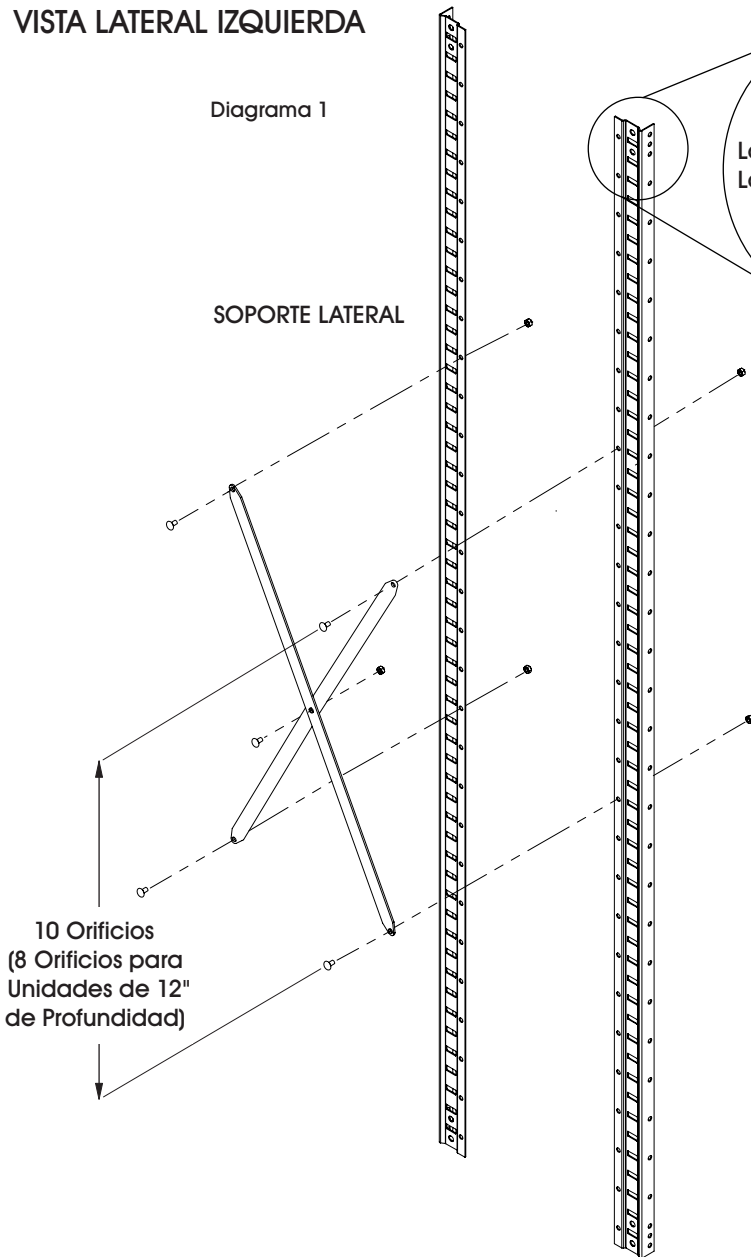

1. Para ensamblar el lateral izquierdo, centre los soportes laterales y fíjelos a los postes. (Vea Diagrama 1)



NOTA: No apriete completamente las tuercas ni los pernos.



NOTA: Para las unidades con una profundidad de 30.5 cm (12") (H-3841, H-3842, H-3843, H-3844) los soportes laterales deberán estar a 8 orificios de distancia.

2. Ensamble el lateral derecho. Repita los pasos mencionados arriba.

VISTA POSTERIOR

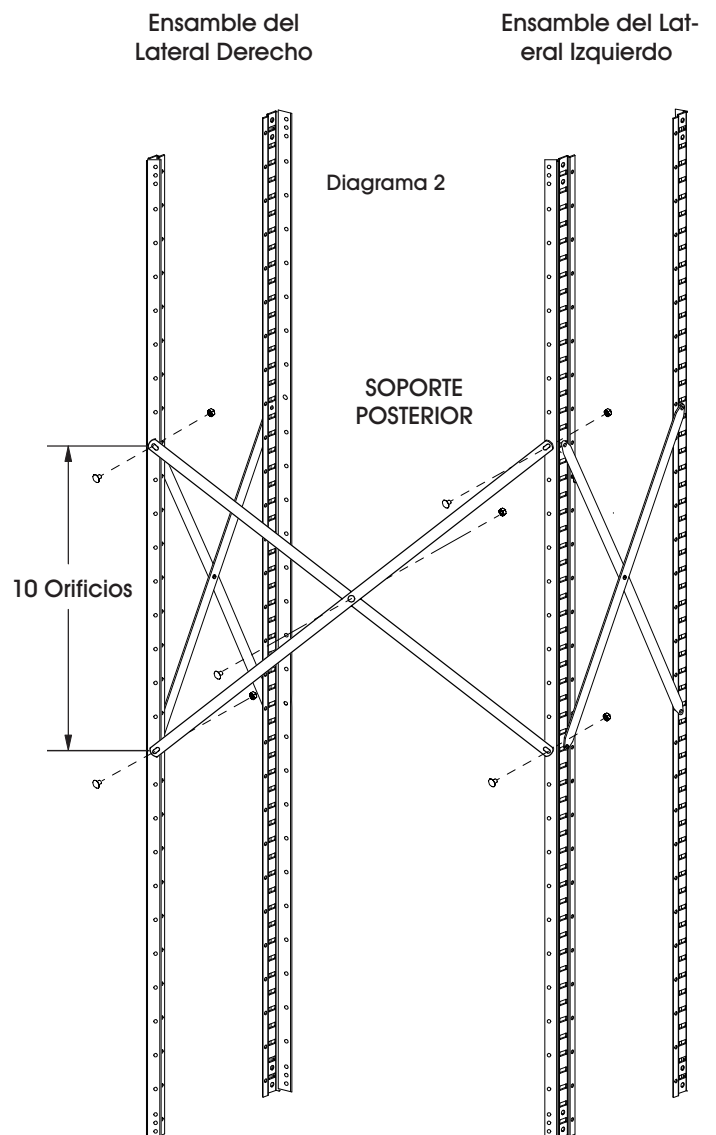

1. Para ensamblar el lado posterior, centre el soporte posterior y fíjelos a los postes. (Vea Diagrama 2)

CONTINUACIÓN DE INSTRUCCIONES

Diagrama 3

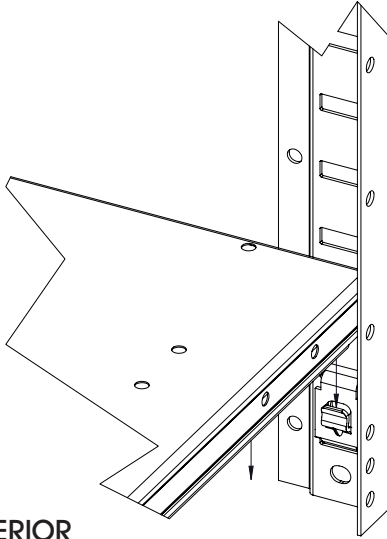

REPISA INFERIOR

1. Inserte los clips en las dos primeras ranuras inferiores de los postes.
2. Inserte la repisa en los clips.

Diagrama 4

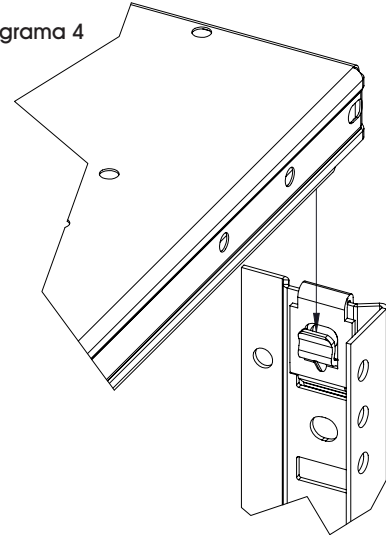

REPISA SUPERIOR

1. Inserte los clips en la ranura superior e inferior de los postes.
2. Inserte la repisa en los clips.

Diagrama 5

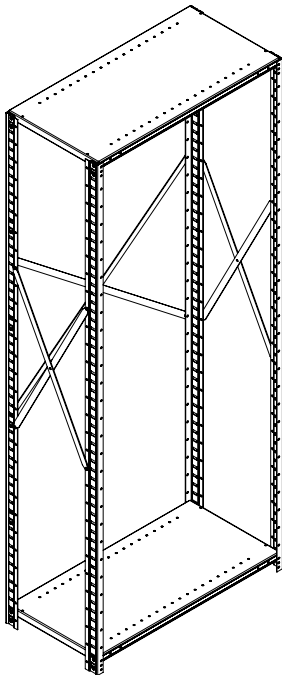

1. Asegúrese de que todos los pernos estén completamente apretados.

Diagrama 6

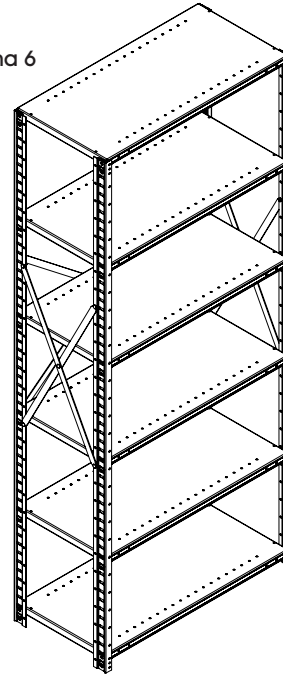

1. Inserte los clips restantes a las alturas de repisa deseadas.
2. Inserte las repisas restantes en los clips.

ULINE

800-295-5510
uline.mx

ULINE

RAYONNAGE EN ACIER INDUSTRIEL

1-800-295-5510
uline.ca

OUTILS REQUIS



Clé de 11 mm

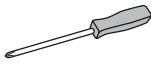

Tournevis
crucefirme



Escabeau
(facultatif)

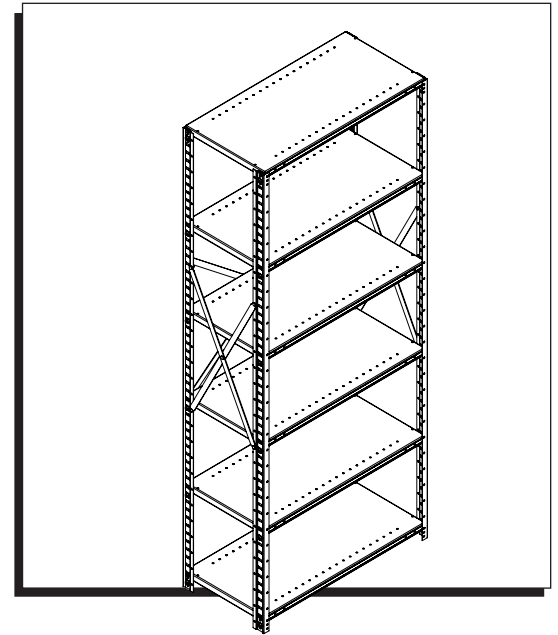

PIÈCES

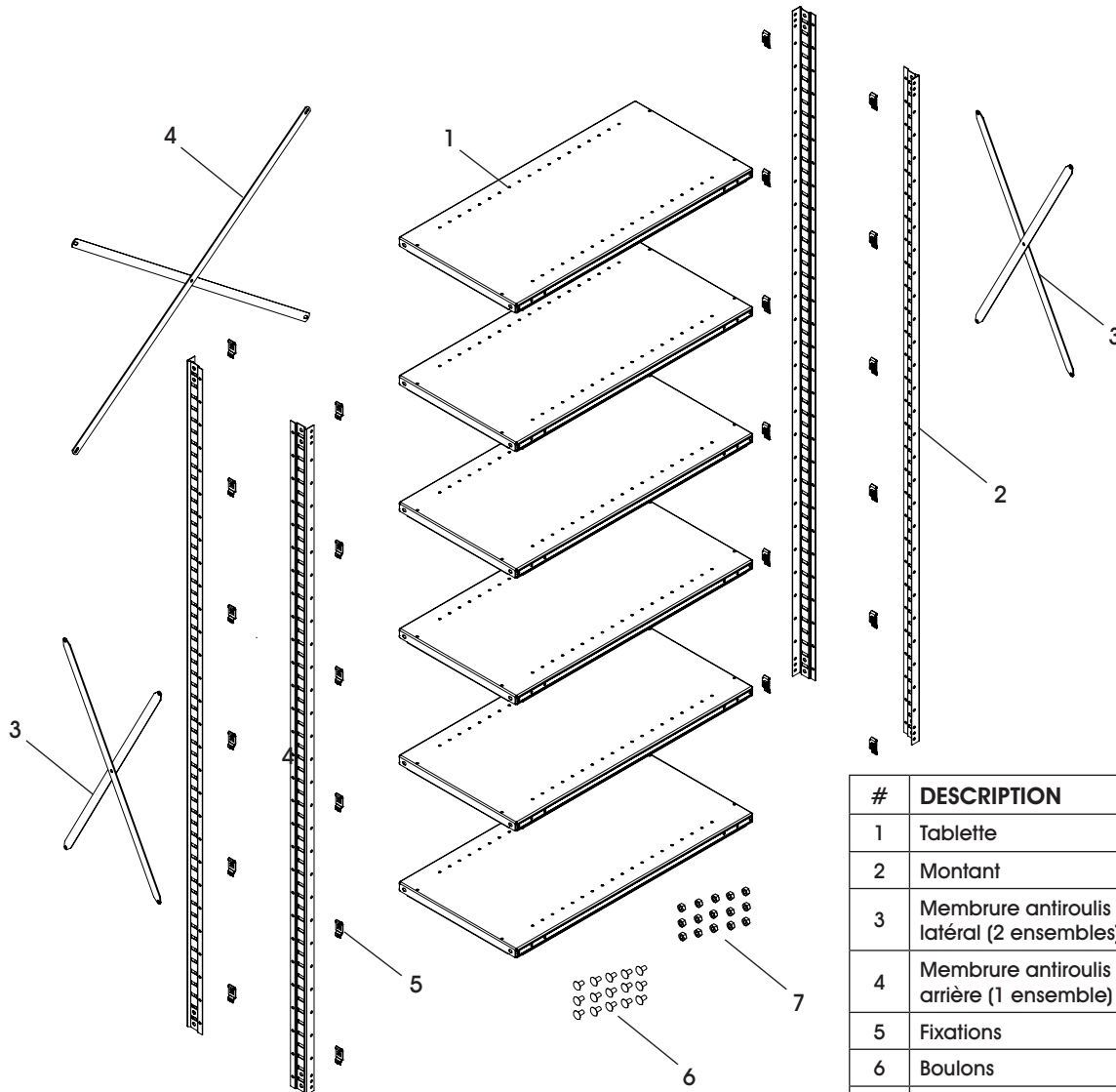

#	DESCRIPTION	QTÉ
1	Tablette	6
2	Montant	4
3	Membre antiroulis latéral (2 ensembles)	4
4	Membre antiroulis arrière (1 ensemble)	2
5	Fixations	24
6	Boulons	15
7	Écrous	15

INSTRUCTIONS

VUE DE GAUCHE

Figure 1

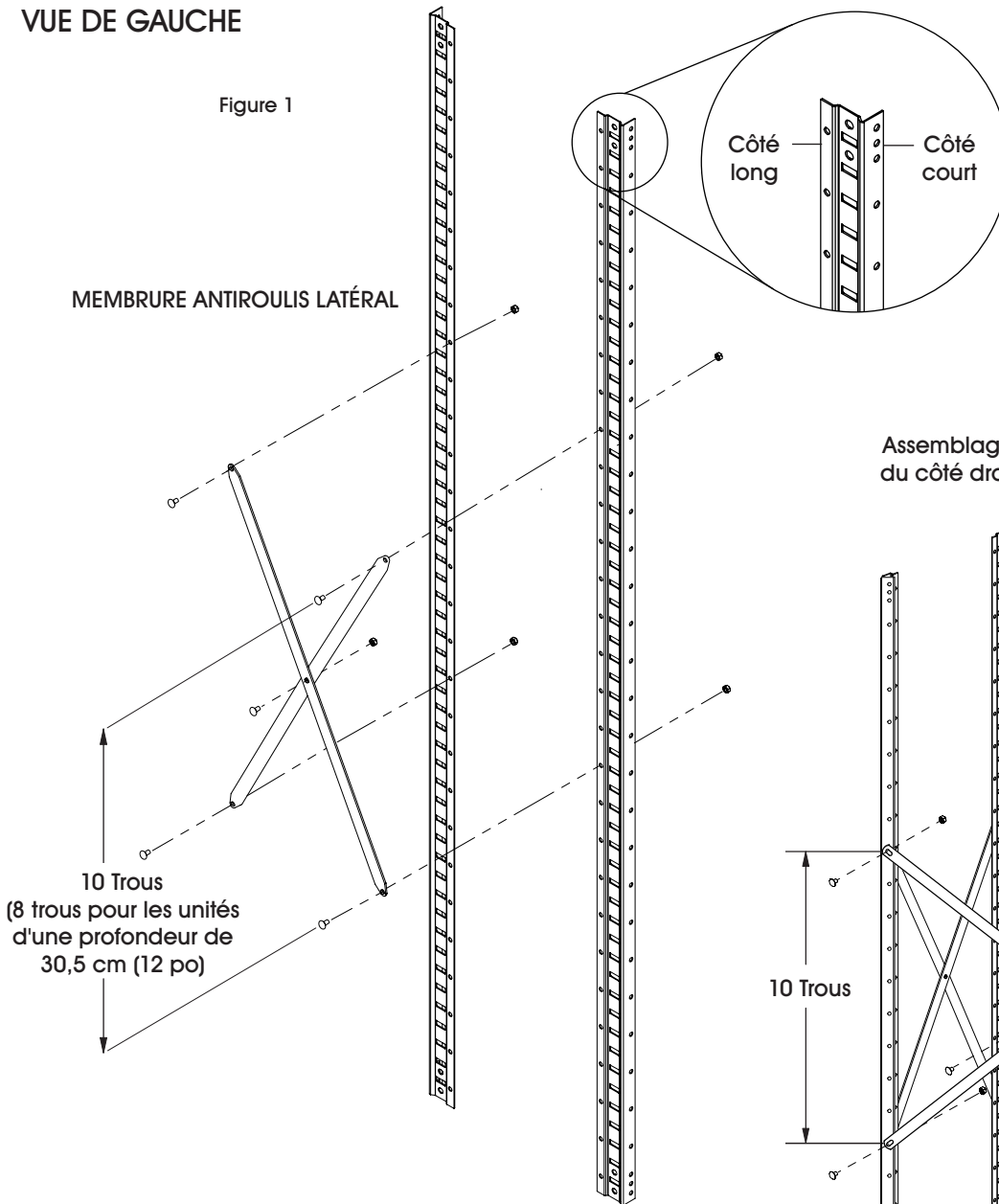

VUE ARRIÈRE

Assemblage
du côté droit

Assemblage du
côté gauche

Figure 2

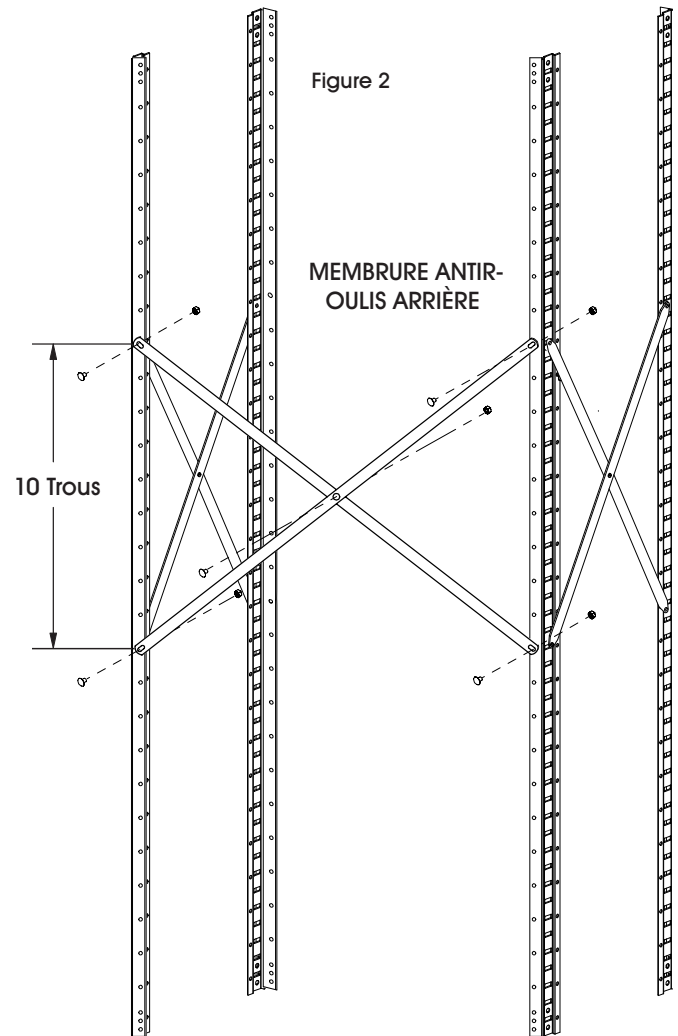

1. Pour monter le côté gauche, centrez les membrures anti-roulis et fixez-les aux montants. (Voir Figure 1)



REMARQUE : Ne serrez pas complètement les écrous et boulons.



REMARQUE : Pour les unités d'une profondeur de 30,5 cm (12 po) (H-3841, H-3842, H-3843, H-3844), les éléments de renforcement latéraux doivent être fixés à huit trous d'intervalle.

2. Montez le côté droit et répétez les étapes ci-dessus.

1. Pour monter le côté arrière, centrez les membrures anti-roulis et fixez-les aux montants. (Voir Figure 2)

INSTRUCTIONS SUITE

Figure 3

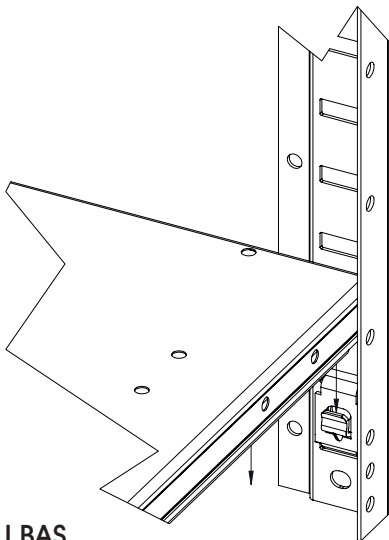

TABLETTE DU BAS

1. Insérez les fixations dans les deux premières fentes inférieures des montants.
2. Emboîtez la tablette dans les fixations.

Figure 4

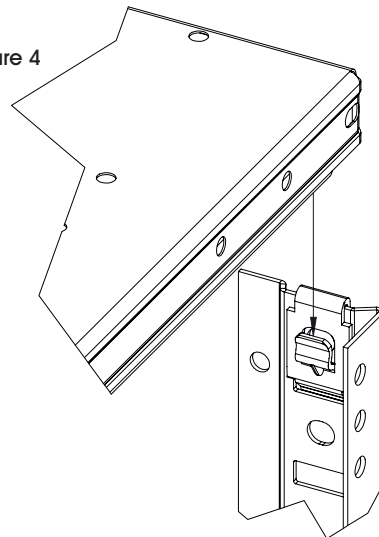

TABLETTE DU HAUT

1. Insérez les fixations dans la fente supérieure et la fente inférieure des montants.
2. Emboîtez la tablette dans les fixations.

Figure 5

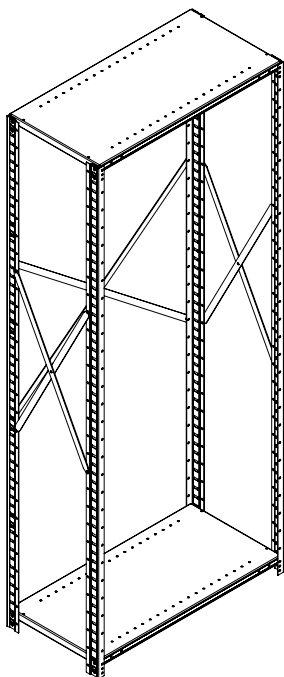

1. Assurez-vous que tous les boulons sont fermement serrés.

Figure 6

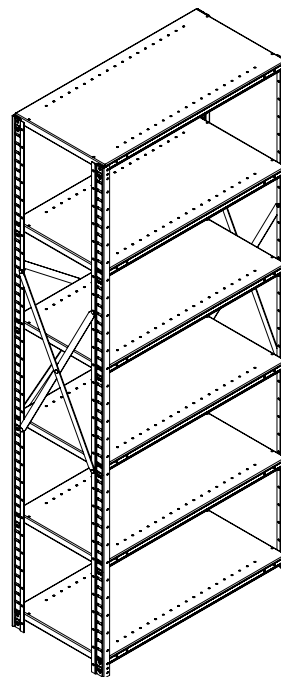

1. Insérez les fixations restantes aux niveaux désirés.
2. Emboîtez les tablettes restantes dans les fixations.

ULINE

1-800-295-5510
uline.ca