

ULINE H-2887 RECYCLED PLASTIC BENCH WITHOUT BACK

1-800-295-5510
uline.com

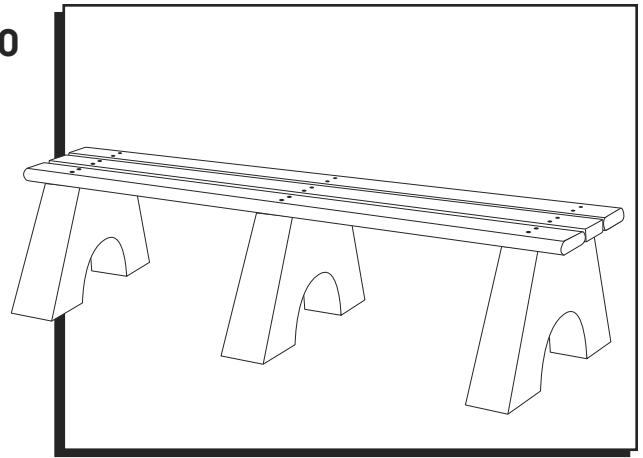

TOOLS NEEDED

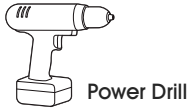

Power Drill



7/16" Socket Bit

PARTS

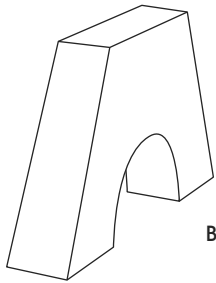

Bench Base x 3

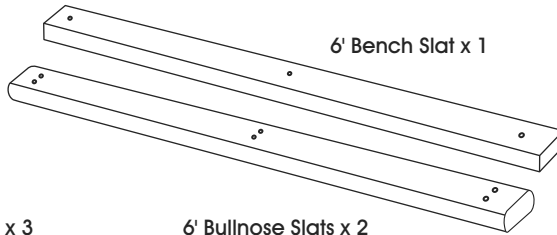

6' Bullnose Slats x 2

6' Bench Slat x 1

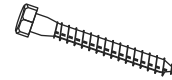

3 1/2" Lag Screws x 18



Washers x 18

ASSEMBLY



IMPORTANT! Keep screws loose throughout assembly. Tighten during step 6.



IMPORTANT! Verify all parts are present before beginning.

1. Place the three bench bases equally spaced on a flat, level surface.
2. Place a bullnose bench slat on the bench bases. Align with the pre-drilled holes.

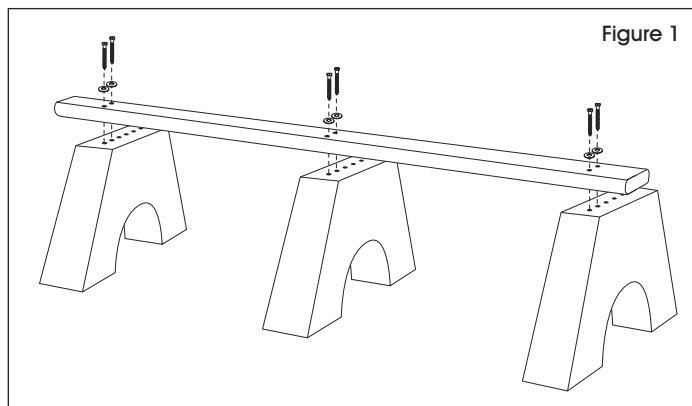

Figure 1

3. Loosely attach bench slat to the bench bases with the 3 1/2" lag screws and washers using the power drill and 7/16" socket bit (will tighten later in step 6). (See Figure 1)
4. For the remaining two bench slats, repeat steps three and four, ensuring second bullnose slat is on far end of assembly. (See Figure 2)
5. Make sure the bench is square and tighten all lag screws.



NOTE: H-2565 Mounting hardware sold separately.

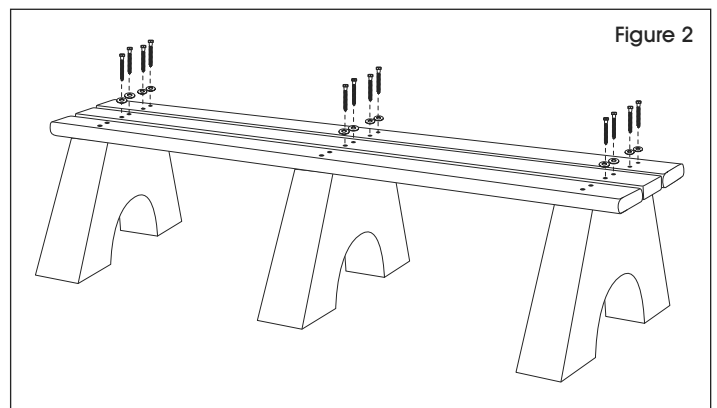
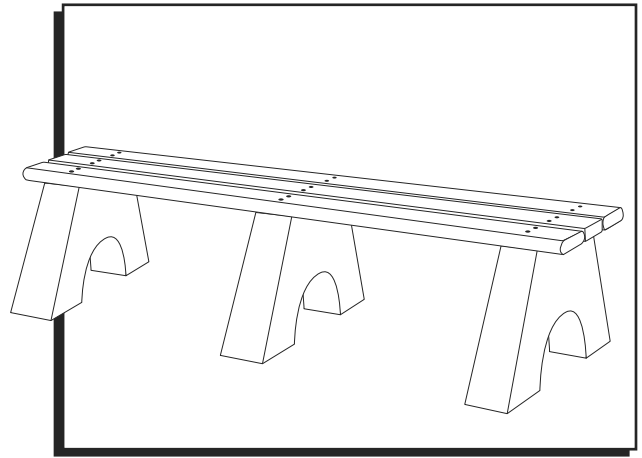

Figure 2

ULINE H-2887
BANCA DE PLÁSTICO
RECICLADO SIN
RESPALDO

800-295-5510
 uline.mx



HERRAMIENTAS NECESARIAS

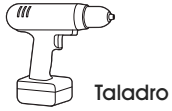

Broca de 7/16"

PARTES

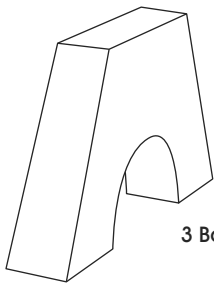

3 Bases para Banca

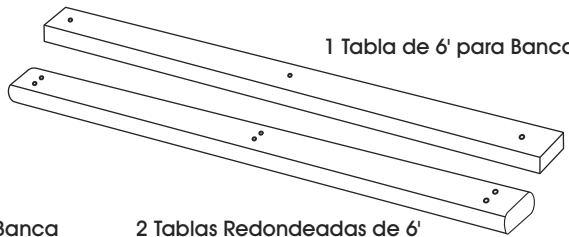

2 Tablas Redondeadas de 6'

1 Tabla de 6' para Banca

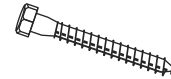

18 Tornillos Tirafondo de 3 1/2"



18 Rondanas

ENSAMBLE



NOTA: Mantener los tornillos aflojados durante el ensamble. Apriételos hasta el paso 6.



¡IMPORTANTE! Verifique que estén todas las partes antes de comenzar.

1. Coloque las tres bases de la banca a distancias iguales sobre una superficie plana y nivelada.
2. Coloque una tabla redondeada sobre las bases de la banca. Alinee con los orificios preperforados.

3. Acople ligeramente la tabla de la banca a las bases con los tornillos tirafondo de 3 1/2" y las rondanas usando el taladro y la broca de 7/16" (se apretarán más adelante en el paso 6). (Vea Diagrama 1)
4. Para las tabla restantes, repita los pasos tres y cuatro, asegurándose de que la segunda tabla esté en el extremo más alejado del ensamble. (Vea Diagrama 2)
5. Asegúrese de que la banca esté en escuadra y apriete todos los tornillos tirafondo.



NOTA: La tornillería de instalación H-2565 se vende por separado.

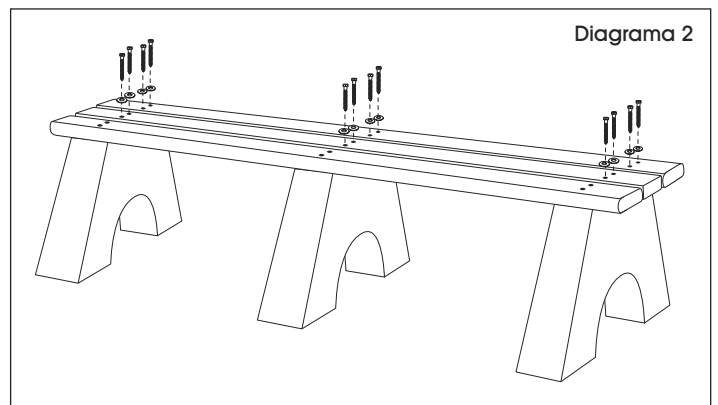
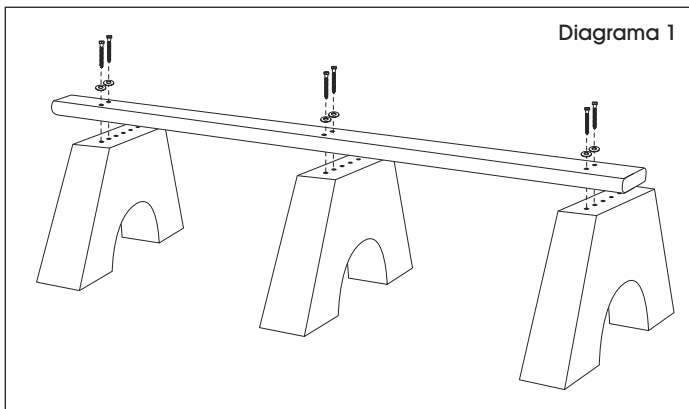

ULINE H-2887

BANC SANS DOSSIER EN PLASTIQUE RECYCLÉ

1-800-295-5510
uline.ca

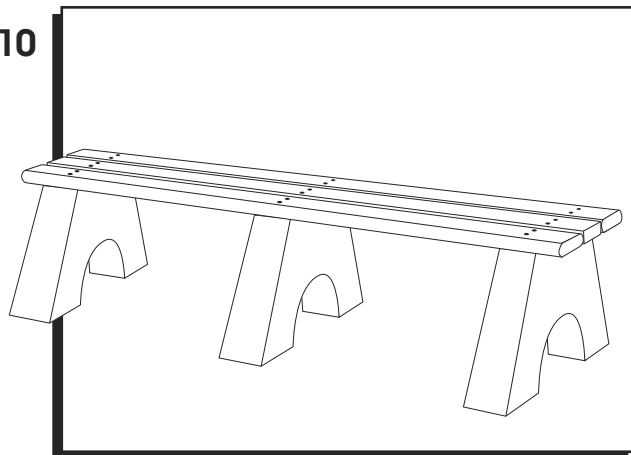

OUTILS REQUIS



Perceuse



Douille tournevis de 7/16 po

PIÈCES

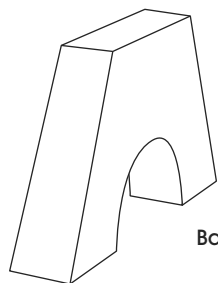

Base de banc x 3

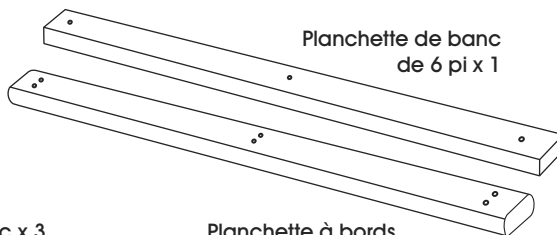

Planchette de banc
de 6 pi x 1

Planchette à bords
arrondis de 6 pi x 2

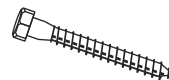

Vis tire-fond de 3 1/2 po x 18



Rondelle x 18

MONTAGE



REMARQUE : De ne pas serrer les vis tire-fonds durant le montage. Le vissage s'effectue à l'étape 6.



IMPORTANT! Assurez-vous que toutes les pièces sont présentes avant de commencer.

1. Placez les trois bases de banc également espacées sur une surface plane et nivelée.
2. Placez une planchette à bords arrondis sur les bases de banc. Alignez-la aux trous prépercés.

3. Fixez la planchette aux bases de banc à l'aide des vis tire-fonds de 3 1/2 po, des rondelles, de la perceuse et de la douille tournevis de 7/16 po (le vissage s'effectuera à l'étape 6). (Voir Figure 1)
4. Répétez les étapes 3 et 4 pour les deux planchettes de banc restantes, en vous assurant que la deuxième planchette à bords arrondis se trouve à l'extérieur. (Voir Figure 2)
5. Assurez-vous que le banc est bien cadré, puis serrez toutes les vis tire-fonds.

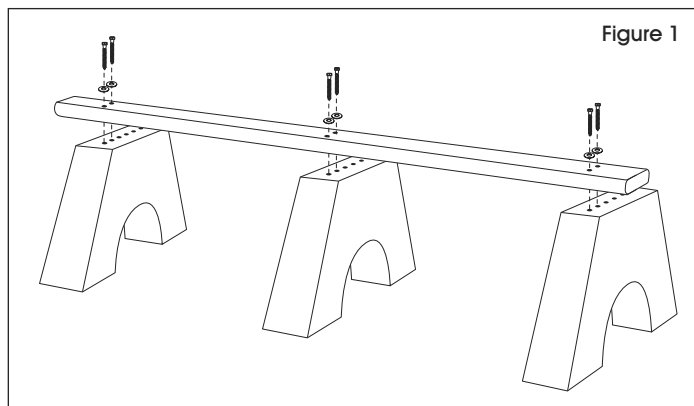

Figure 1



REMARQUE : Le matériel d'installation H-2565 est vendu séparément.

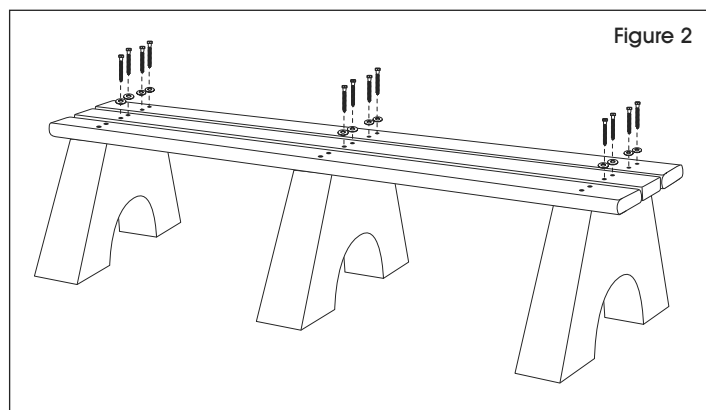

Figure 2