

ULINE H-2920, H-2921, H-2922
H-4468, H-4469

MAIL SORTER

1-800-295-5510
uline.com

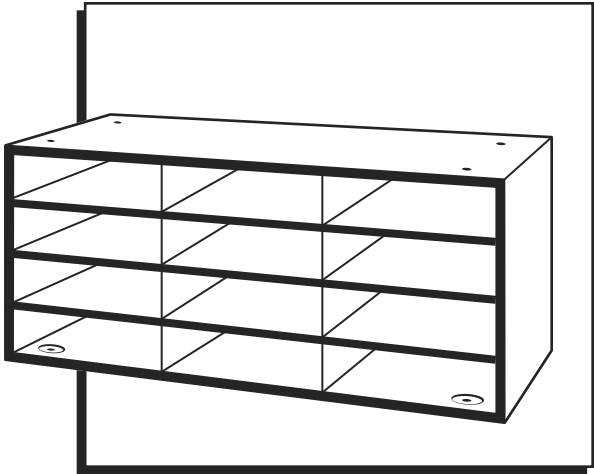

TOOLS NEEDED

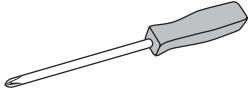

Phillips Screwdriver



3/8" Wrench

TOOLS NEEDED FOR OPTIONAL WALL MOUNTING



Power Drill



1/4" Drill Bit



1/16" Drill Bit

PARTS

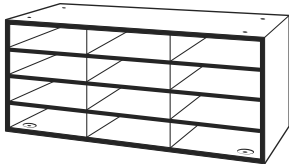

Mail Sorter Unit x 1

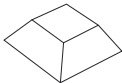

Rubber Foot x 4



1/2" Bolt x 2



3/8" Bolt x 2



Nut x 4



Screw x3
(Included)
(Optional)



Drywall Anchor x3
(Included)
(Optional)

ASSEMBLY

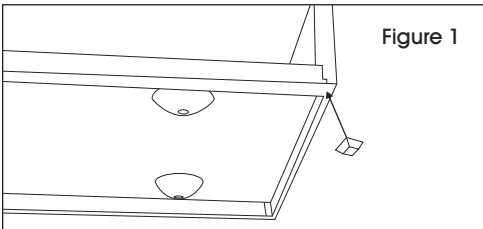

Figure 1

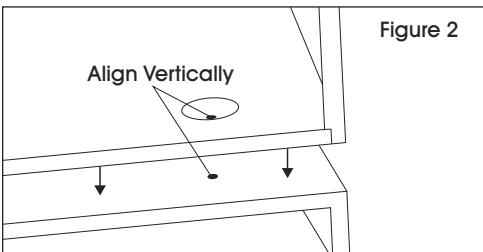

Figure 2

Align Vertically

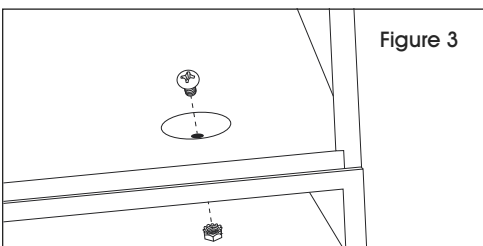

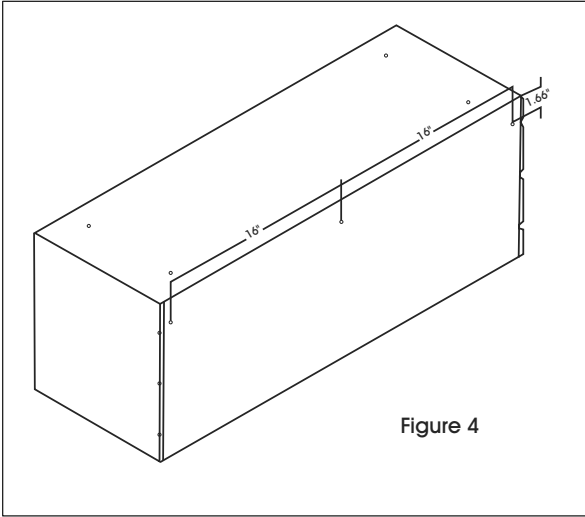

Figure 3

1. To prevent sliding or scratching when mounting an individual rack directly on the floor or on a desk, attach self-adhesive rubber feet to four bottom corners. (See Figure 1)
 2. When combining modular units to construct a larger rack, place individual racks on top of each other, making sure to line up the mounting holes located on the top and bottom of each unit. (See Figure 2)
-  **NOTE:** For H-4468, stack two 15-compartment mail sorters on top of each other. For H-4469, stack three 15-compartment mail sorters on top of each other.
3. Insert four bolts provided into recessed mounting holes. Use the 1/2" bolts for the rear holes and the 3/8" bolts for the front holes. Attach four nuts provided and tighten securely using Phillips screwdriver and 3/8" wrench. Repeat this procedure until all racks are connected. (See Figure 3)

WALL MOUNTING (OPTIONAL)



NOTE: Mounting hardware is intended for drywall.

1. Three mounting holes, located on 16" centers, are on the back of the mail sorter. (See Figure 4)
2. On the wall where the cabinet is to be mounted, mark three points 16" apart in a level, straight line.



NOTE: If points are located on a wall stud, you will not use the drywall anchors. Otherwise, anchors must be used.

3. Pre-drill the three holes using a 1/4" drill bit for the drywall anchors or 1/16" drill bit if using screws only.
4. Insert the drywall anchor into 1/4" pre-drilled hole and screw in tightly.
5. Insert a screw (into the anchor, if used, or directly into pre-drilled hole) and turn screw until almost tight, leaving a 1/16" gap. Repeat this procedure for each hole.
6. Hang the cabinet on the wall, ensuring that all three holes are mounted on the screws.
7. Once mounted, tighten the screws by reaching in through the front of the mail sorter.

ULINE

1-800-295-5510
uline.com



H-2920, H-2921, H-2922
H-4468, H-4469

800-295-5510
uline.mx

CLASIFICADOR DE CORREO

HERRAMIENTAS NECESARIAS

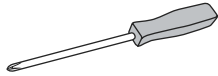

Desarmador de Cruz



Llave de 3/8"

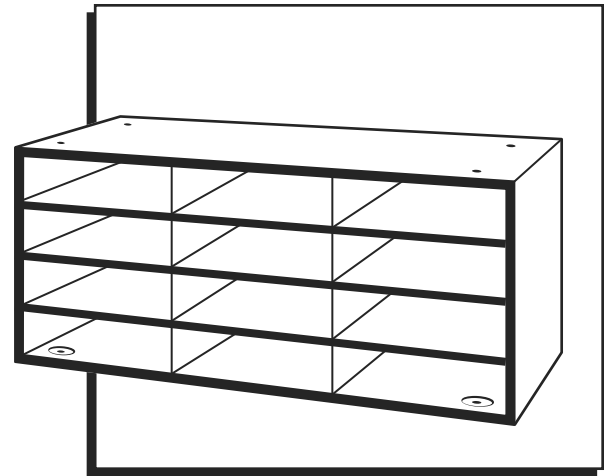

HERRAMIENTAS REQUERIDAS PARA INSTALACIÓN OPCIONAL EN PARED



Taladro



Broca de 1/4"



Broca de 1/16"

PARTES

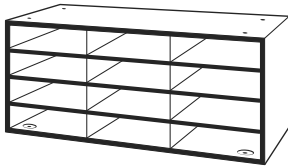

1 Clasificador de Correo

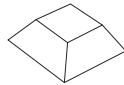

4 Patas de Goma

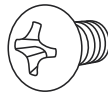

2 Pernos de 1/2"



2 Pernos de 3/8"



4 Tuercas



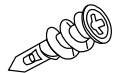

3 Tornillos (incluidos) (opcional)

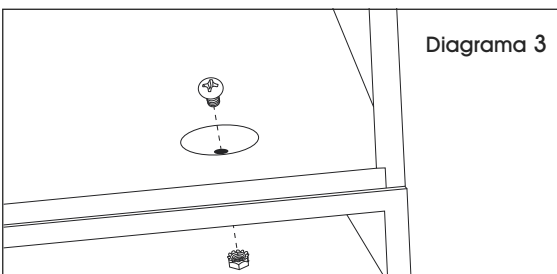
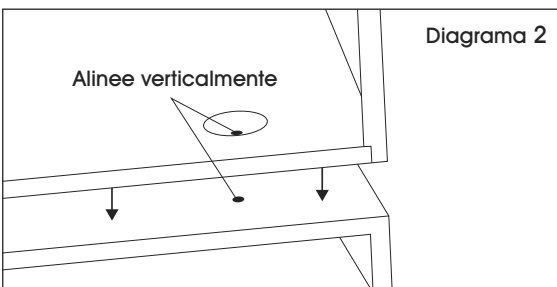
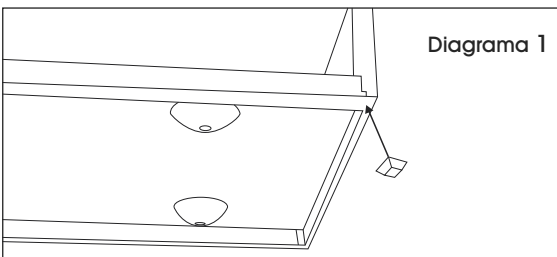

3 Anclajes para Tablaroca (incluidos) (opcional)

ENSAMBLE



1. Para evitar que la unidad resbale o se raye al montar un rack individual directamente sobre el piso o en un escritorio, asegure las patas de goma autoadhesivas a las cuatro esquinas de la parte inferior. (Vea Diagrama 1)
 2. Cuando combine unidades modulares para construir un rack más grande, coloque los racks individuales uno encima del otro, asegurándose de alinear los orificios de montaje en las partes superior e inferior de cada unidad. (Vea Diagrama 2)
-  **NOTA:** Para H-4468, estibe dos clasificadores de correo de 15 compartimentos uno encima del otro. Para H-4469, estibe tres clasificadores de correo de 15 compartimentos uno encima del otro.
3. Inserte los cuatro pernos provistos en los orificios de montaje empotrados. Utilice los pernos de 1/2" para los orificios posteriores y los pernos de 3/8" para los frontales. Acople las cuatro tuercas provistas y apriete con firmeza usando el desarmador de cruz y las llave de 3/8". Repita este procedimiento hasta que todos los racks estén sujetos. (Vea Diagrama 3)

INSTALACIÓN EN PARED (OPCIONAL)

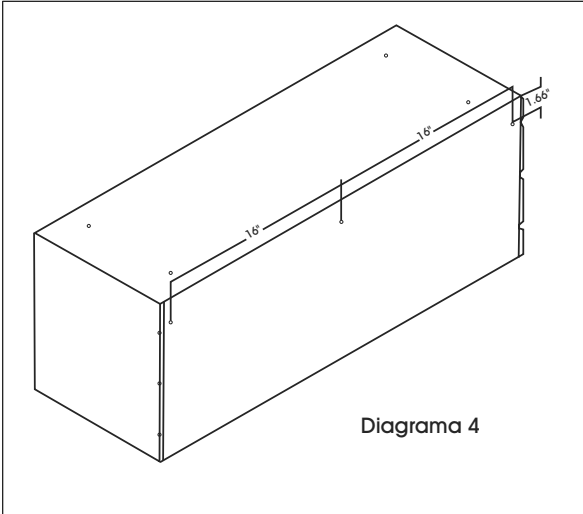

NOTA: La tornillería para instalación está indicada para tablaroca.

1. Los tres orificios para instalación, están localizados en centros de 16" en la parte posterior del clasificador de correo. (Vea Diagrama 4)
2. En la pared donde vaya a instalar el gabinete, marque tres puntos apartados a 16" en una línea recta nivelada.



NOTA: Si los puntos están localizados en un soporte del muro, no utilizará los anclajes para tablaroca. De otra forma, se deben utilizar los anclajes.

3. Pretaladre los tres orificios utilizando una broca de 1/4" para anclajes de tablaroca o broca de 1/16" si utiliza tornillos solamente.
4. Inserte el anclaje para tablaroca en el orificio pretaladrado de 1/4" y atornille firmemente.
5. Inserte un tornillo (dentro del anclaje, si lo utilizó, o directamente dentro del orificio pretaladrado) y gire el tornillo hasta casi apretarlo, dejando un espacio de 1/16". Repita este procedimiento en cada orificio.
6. Cuelgue el gabinete en la pared, asegúrese que los tres orificios están instalados en los tornillos.
7. Una vez instalado, apriete los tornillos desde el frente del clasificador de correo.

ULINE

800-295-5510
uline.mx

OUTILS REQUIS

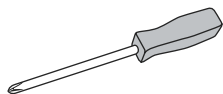

Tournevis cruciforme

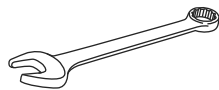

Clé de 3/8 po

OUTILS REQUIS POUR L'INSTALLATION MURALE FACULTATIVE



Perceuse



Mèche de 1/4 po



Mèche de 1/16 po

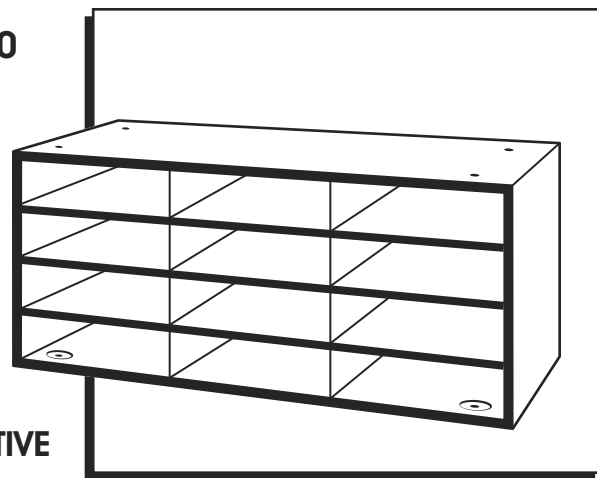

PIÈCES

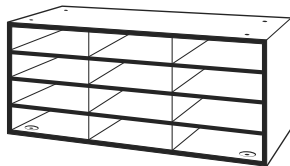

Unité de classe-courrier x 1

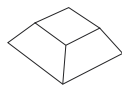

Patte en caoutchouc x 4

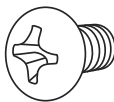

Boulon de 1/2 po x 2



Boulon de 3/8 po x 2



Écrou x 4



Écrou x 3 (fourni) (optionnel)



Boulon d'ancrage x 3 (fourni) (optionnel)

MONTAGE

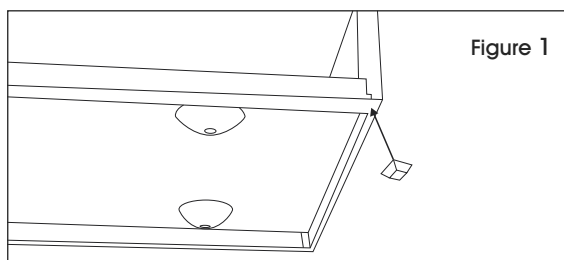

Figure 1

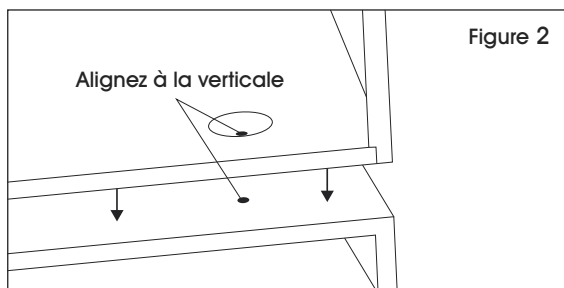

Figure 2

Alignez à la verticale

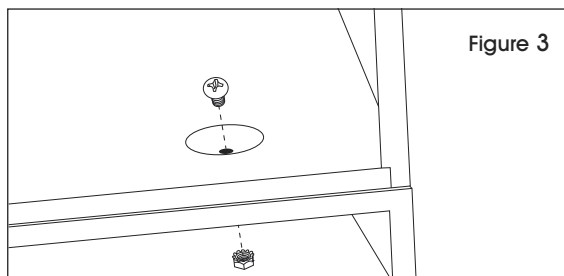

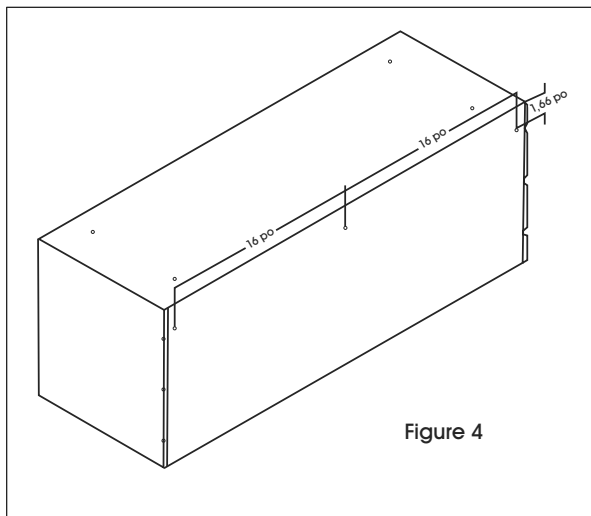

Figure 3

1. Afin d'éviter tout glissement ou éraflure lors de l'installation d'un classe-courrier directement sur le plancher ou sur un bureau, fixez les pattes en caoutchouc autocollantes sous les quatre coins du bas. (Voir Figure 1)
 2. Lorsque vous combinez plusieurs unités pour assembler un meuble de plus grande taille, empilez les classe-courrier les uns sur les autres en vous assurant d'aligner les trous de montage situés sur le dessus et le dessous de chaque unité. (Voir Figure 2)
-  **REMARQUE :** Pour le H-4468, empilez deux classe-courrier à 15 compartiments l'un sur l'autre. Pour le H-4469, empilez trois classe-courrier à 15 compartiments les uns sur les autres.
3. Insérez les quatre boulons fournis dans les trous de montage en retrait. Utilisez les boulons de 1/2 po pour les trous arrière et ceux de 3/8 po pour les trous avant. Installez les quatre écrous fournis et serrez fermement avec le tournevis Phillips et la clé de 3/8 po. Répétez cette procédure jusqu'à ce que tous les classe-courrier soient raccordés. (Voir Figure 3)

INSTALLATION MURALE (FACULTATIVE)



REMARQUE : Le matériel d'installation murale est prévu pour la cloison sèche.

1. Il y a trois trous de montage centrés tous les 16 po au dos du classe-courrier. (Voir Figure 4)
2. Marquez trois points espacés de 16 po en ligne droite sur le mur où le classe-courrier sera installé.



REMARQUE : Si les points se trouvent sur un poteau mural, n'utilisez pas les boulons d'ancrage pour cloison sèche. Autrement, l'utilisation de boulons d'ancrage est obligatoire.

3. Percez trois trous en vous servant d'une mèche de 1/4 po pour la cloison sèche, ou sinon d'une mèche de 1/16 po pour l'utilisation avec uniquement des vis.
4. Insérez le boulon d'ancrage pour cloison sèche dans le trou prépercé et vissez-le fermement.
5. Insérez une vis (dans le boulon d'ancrage, si utilisé, ou directement dans le trou prépercé) et tournez la vis jusqu'à ce qu'elle soit presque entièrement serrée, tout en laissant un espace de 1/16 po. Répétez cette étape pour chaque trou.
6. Pendez le classe-courrier au mur en vous assurant que les vis rentrent dans chacun des trois trous.
7. Une fois le classe-courrier installé au mur, accédez aux vis par l'intérieur et serrez-les.

ULINE

1-800-295-5510
uline.ca