

ULINE H-3199

ALUMINUM STANDARD HAND TRUCK

WITH EXTRA-LARGE NOSE PLATE
 AND SOLID RUBBER WHEELS

1-800-295-5510
 uline.com

TOOLS NEEDED



6 mm Allen Wrench



13 mm Wrench



14 mm Wrench

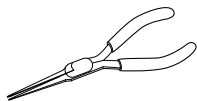

Pliers

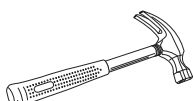

Hammer

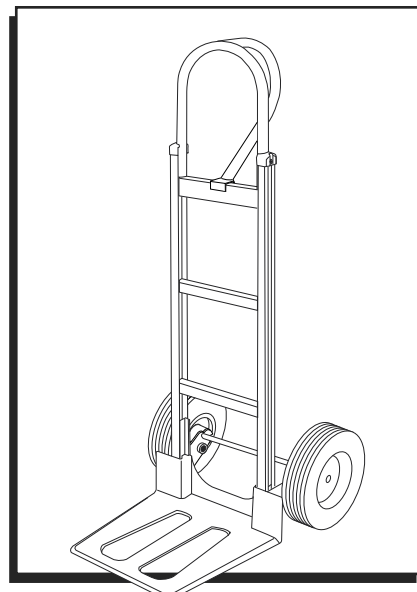

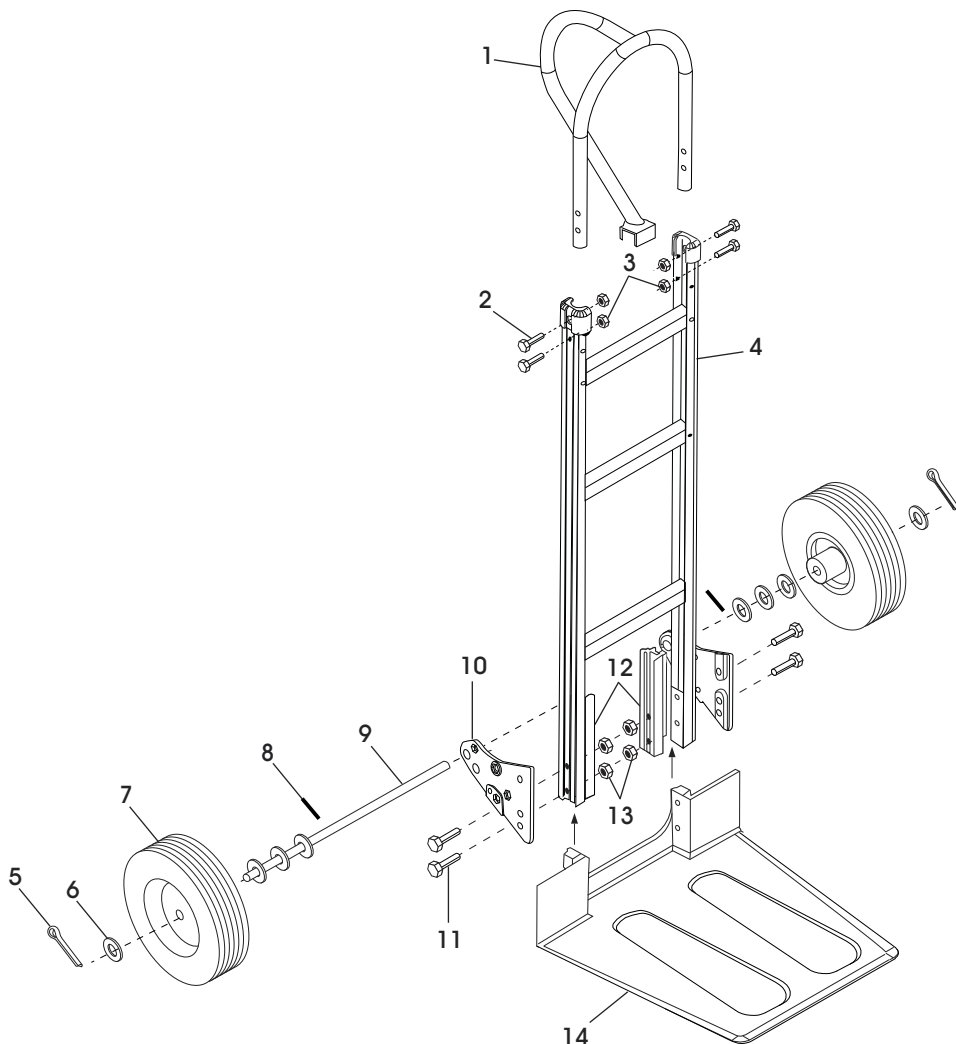

PARTS LIST

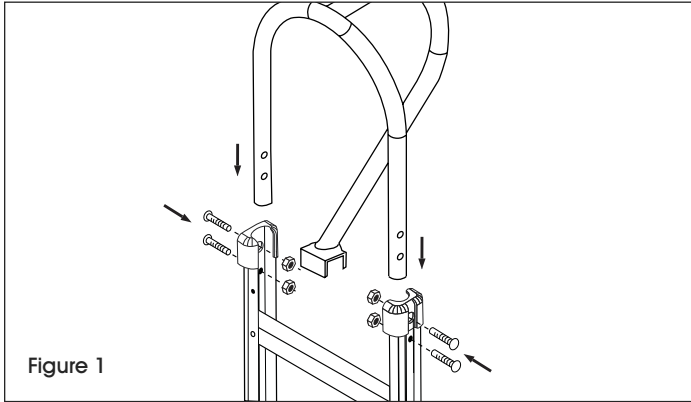

#	QTY.	DESCRIPTION
1	1	Handle
2	4	6mm Bolt
3	4	6mm Locknut
4	1	Frame
5	2	Cotter Pin
6	8	Washer
7	2	Wheel
8	2	Round Pin
9	1	Axle
10	2	Axle Support
11	4	8mm Bolt
12	2	Frame Reinforcement
13	4	8mm Locknut
14	1	Nose Plate

ASSEMBLY INSTRUCTIONS



 **NOTE:** Do not use air or power tools.

ATTACH HANDLE

1. Unscrew and remove four 6 mm bolts and locknuts from top rails of frame. Slide handle into frame. Align holes in handle and frame. Insert bolts back through the frame and handle and secure with locknuts. (See Figure 1)

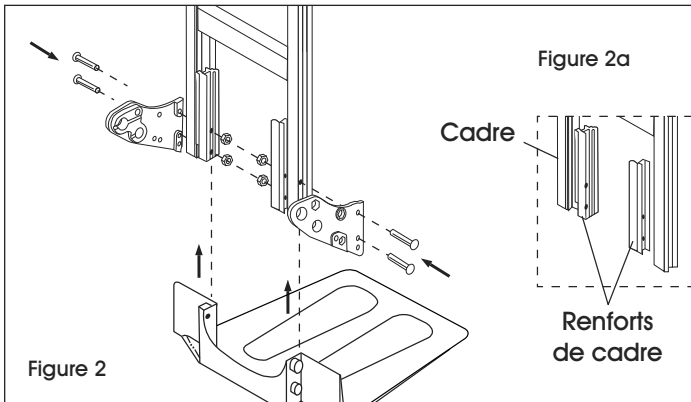

ATTACH NOSE PLATE AND AXLE SUPPORTS

1. Position frame reinforcements against bottom frame rail. (See Figure 2a) Slide nose plate into channel on frame reinforcement, keeping bolt holes aligned. (See Figure 2)
2. Align axle support with outside rail of frame. (See Figure 2)
3. Insert four 8 mm bolts through the axle supports, frame, frame reinforcements and nose plate. Secure with locknuts but **DO NOT** tighten. (See Figure 2)

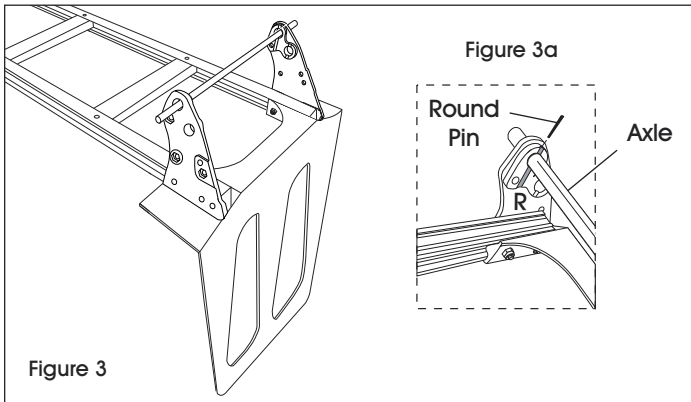

ATTACH AXLE AND WHEELS

1. Lay hand truck on front so axle supports face upwards. (See Figure 3)



WARNING: If installing stair climber, refer to instructions included with stair climber and skip step 2. Once complete, continue with step 3. If not installing stair climber, continue to step 2.

2. Insert axle through top holes in axle supports. Align holes in axle with grooves on inside of the axle supports. Use a hammer to tap in the round pins. (See Figure 3a)
3. Slide three washers onto each end of the axle. Slide a wheel onto each end of the axle. Slide on another washer onto each end of the axle. (See Figure 4)
4. Insert a cotter pin through the holes in each end of the axle. Bend cotter pins using pliers to secure wheels. Wheels should spin freely. (See Figure 4)
5. Tighten all lock nuts.

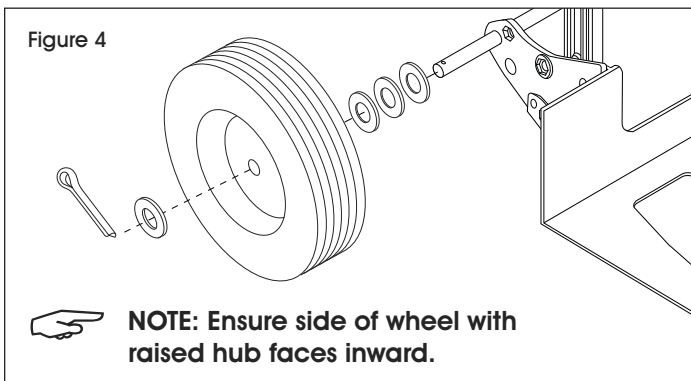

ULINE

1-800-295-5510

uline.com

ULINE H-3199

**DIABLITO DE ALUMINIO
ESTÁNDAR
CON BASE EXTRAGRANDE
Y LLANTAS DE CAUCHO SÓLIDO**

800-295-5510
uline.mx

HERRAMIENTAS NECESARIAS



Llave Allen de 6 mm



Llave de 13 mm



Llave de 14 mm

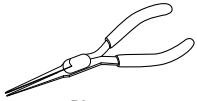

Pinzas

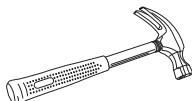

Martillo

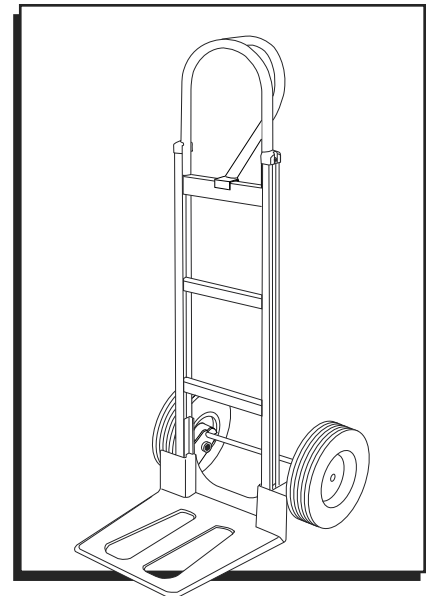

LISTA DE PARTES

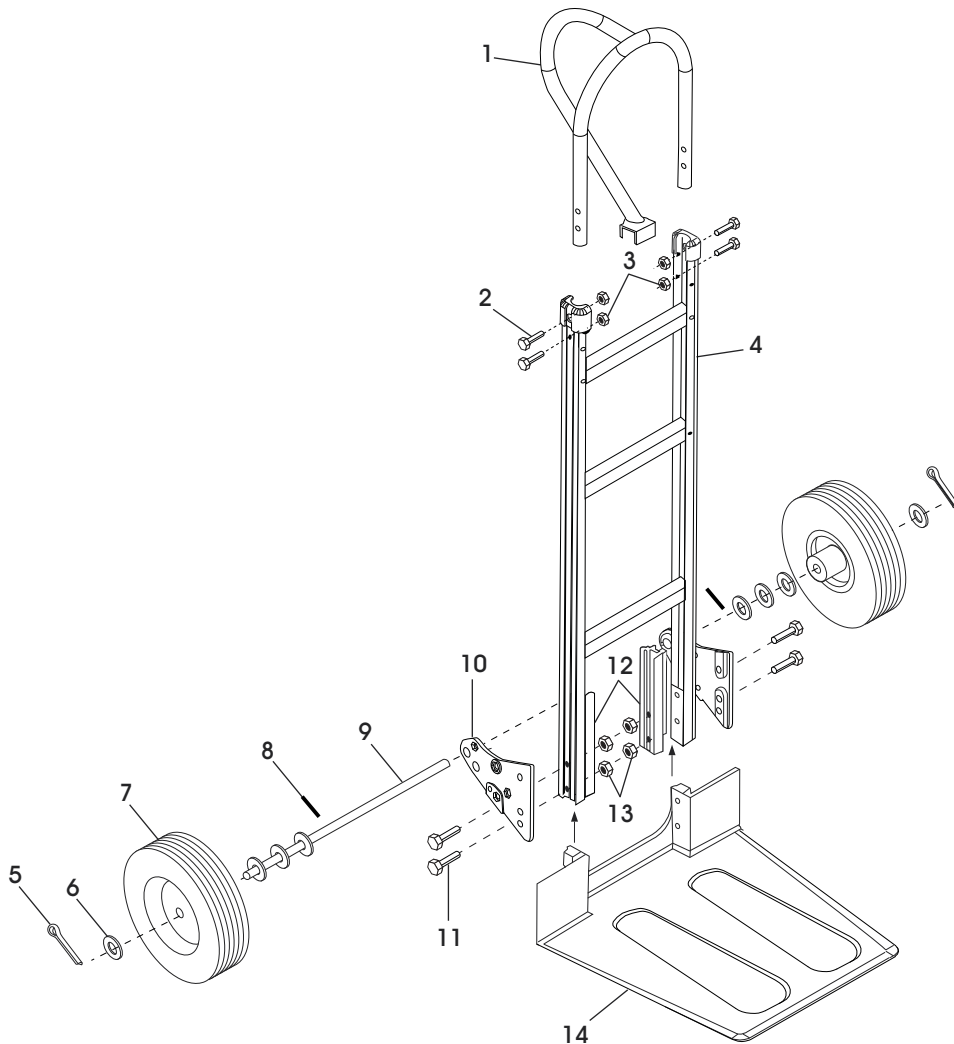

#	CANT.	DESCRIPCIÓN
1	1	Asa
2	4	Perno de 6 mm
3	4	Contratuera de 6 mm
4	1	Armazón
5	2	Pasador de Chaveta
6	8	Rondana
7	2	Llanta
8	2	Pasador Redondo
9	1	Eje
10	2	Soporte del Eje
11	4	Perno de 8 mm
12	2	Refuerzo del Armazón
13	4	Contratuera de 8 mm
14	1	Base

INSTRUCCIONES DE ENSAMBLE



Diagrama 1

 **NOTA:** No use herramientas eléctricas ni neumáticas.

FIJE EL ASA

1. Desatornille y quite los cuatro pernos de 6 mm y las contratuercas de la parte superior del riel del armazón. Deslice el asa en el armazón. Alinee los orificios del asa y el armazón. Inserte otra vez los pernos a través del armazón y el asa y fíjelos con las contratuercas. (Vea Diagrama 1)

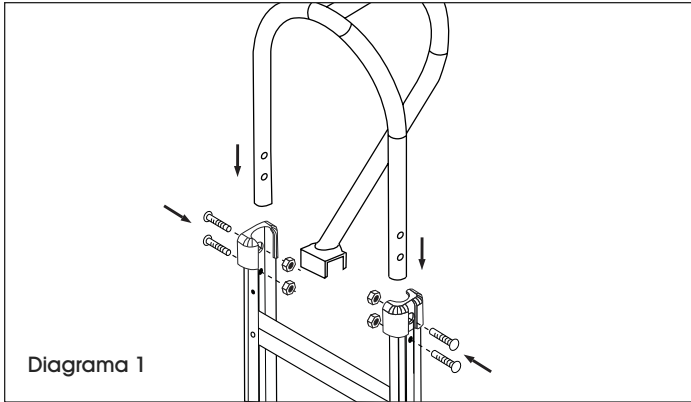
FIJE LA BASE Y LOS SOPORTES DEL EJE

1. Coloque los refuerzos del armazón contra el fondo del riel del armazón. (Vea Diagrama 2a) Deslice la base hacia el canal en los refuerzos del armazón, manteniendo alineados los orificios de los pernos. (Vea Diagrama 2)
2. Alinee el soporte del eje con el riel exterior del armazón. (Vea Diagrama 2)
3. Inserte cuatro pernos de 8 mm a través de los soportes del eje, el armazón, los refuerzos del armazón y la base. Asegure con contratuercas pero **NO** apriete. (Vea Diagrama 2)



Diagrama 2

FIJE EL EJE Y LAS LLANTAS

1. Apoye el diablito sobre su parte delantera de forma que los soportes del eje apunten hacia arriba. (Vea Diagrama 3)



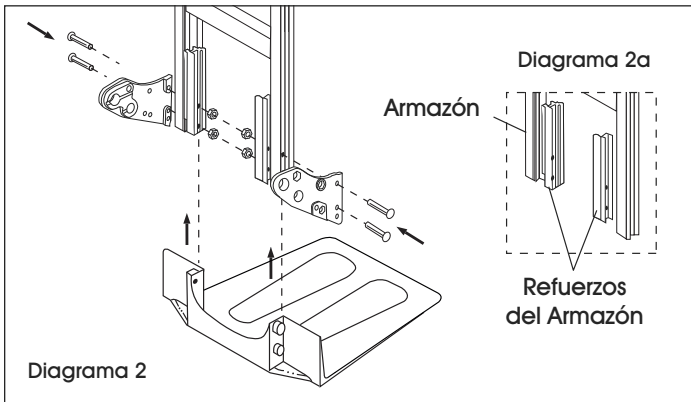

Diagrama 3

 **ADVERTENCIA:** Si va a colocar el aditamento para escaleras, siga las instrucciones que incluye el aditamento y omita el paso 2. Una vez que termine de instalar, continúe con el paso 3. Si no va a colocar el aditamento para escaleras, continúe con el paso 2.

2. Inserte el eje a través de los orificios superiores en los soportes del eje. Alinee los orificios del eje con las muescas de la parte interior de los soportes del eje. Use un martillo para introducir los pasadores redondos. (Vea Diagrama 3a)
3. Deslice tres rondanas en cada extremo del eje. Deslice una llanta en cada extremo del eje. Deslice otra rondana en cada extremo del eje. (Vea Diagrama 4)
4. Inserte un pasador de chaveta a través de los orificios en cada extremo del eje. Doble los pasadores de chaveta usando unos alicates para asegurar las llantas. Las llantas deben girar libremente. (Vea Diagrama 4)
5. Apriete todas las contratuercas.

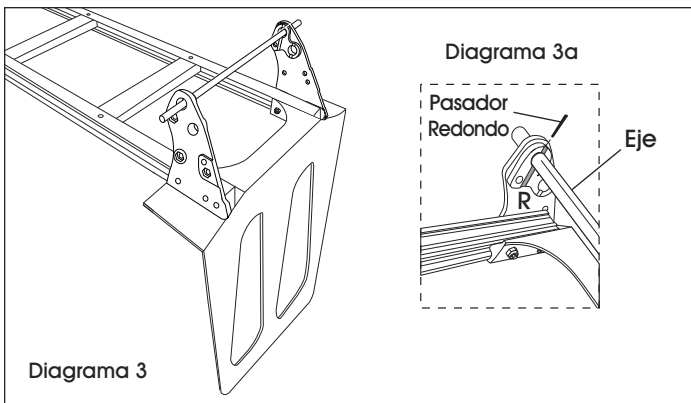



Diagrama 4

 **NOTA:** Asegúrese de que el lado de la llanta con el núcleo elevado quede hacia adentro.

ULINE

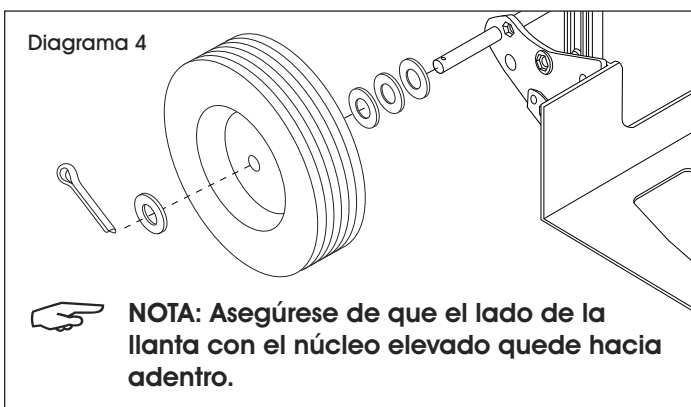
800-295-5510
uline.mx

ULINE H-3199

DIABLE DE MANUTENTION STANDARD EN ALUMINIUM

AVEC BAVETTE TRÈS LARGE
ET ROUES PLEINES

1 800 295-5510

uline.ca

OUTILS REQUIS



Clé Allen de 6 mm



Clé de 13 mm



Clé de 14 mm

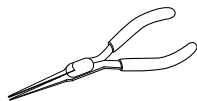

Pince

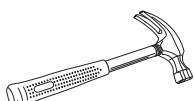

Marteau

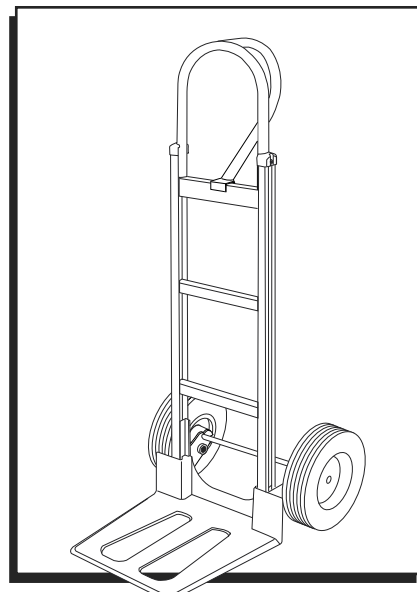

LISTE DES PIÈCES

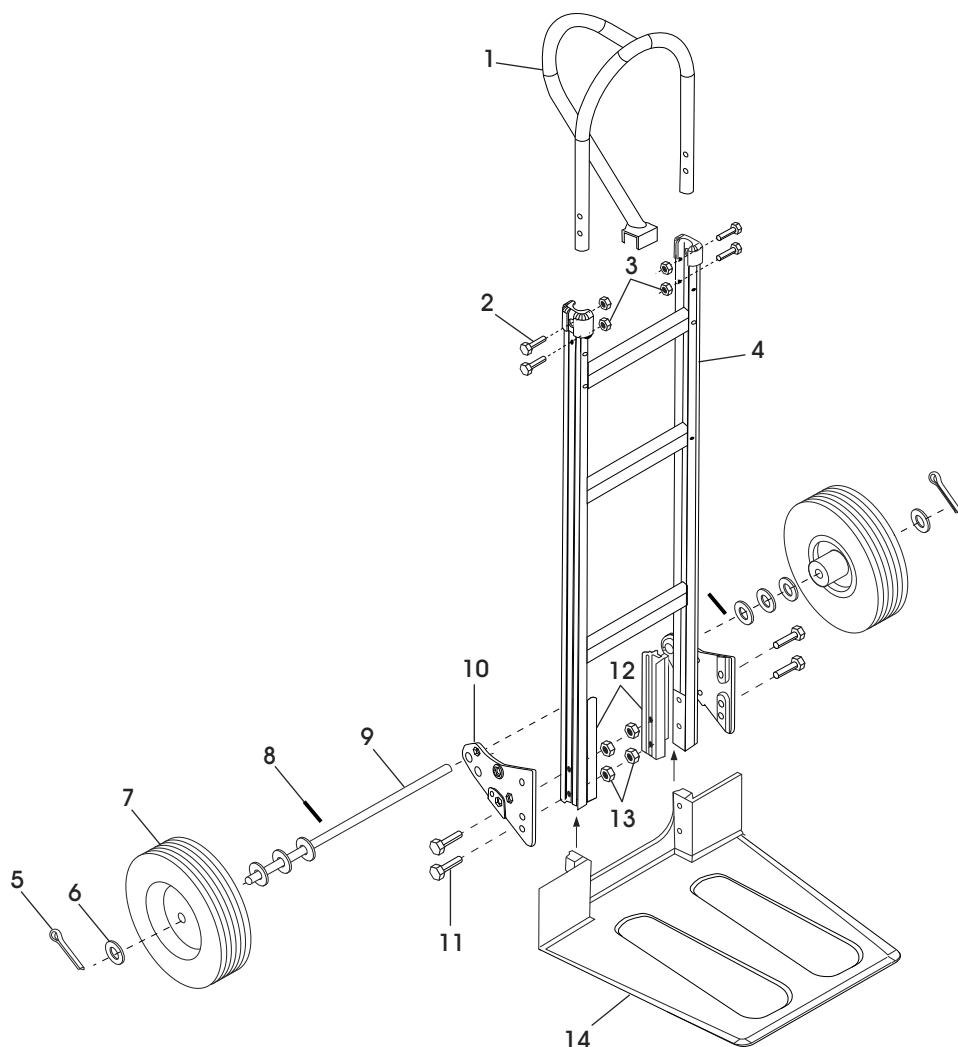

#	QTÉ	DESCRIPTION
1	1	Poignée
2	4	Boulon de 6 mm
3	4	Écrou freiné de 6 mm
4	1	Cadre
5	2	Goupille fendue
6	8	Rondelle
7	2	Roue
8	2	Goupille
9	1	Essieu
10	2	Support d'essieu
11	4	Boulon de 8 mm
12	2	Renfort de cadre
13	4	Écrou freiné de 8 mm
14	1	Bavette

INSTRUCTIONS DE MONTAGE

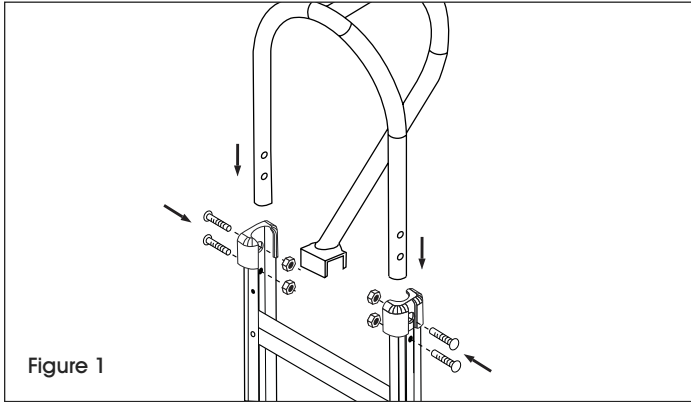

Figure 1

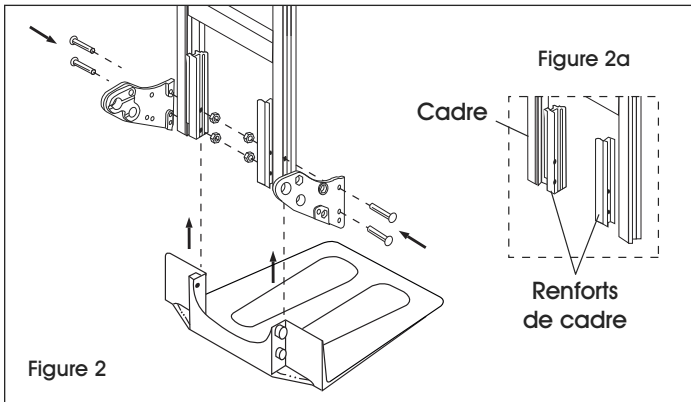

Figure 2

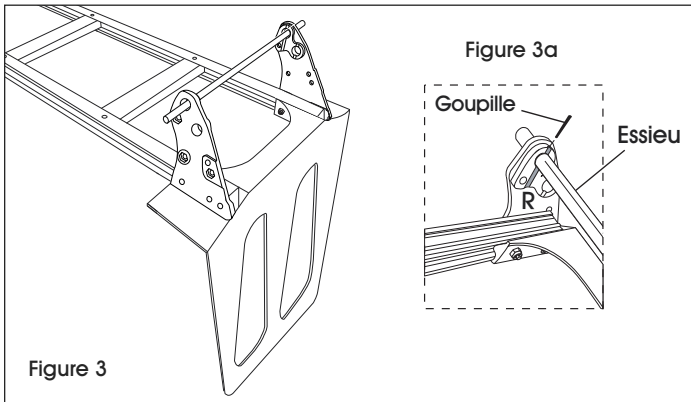

Figure 3

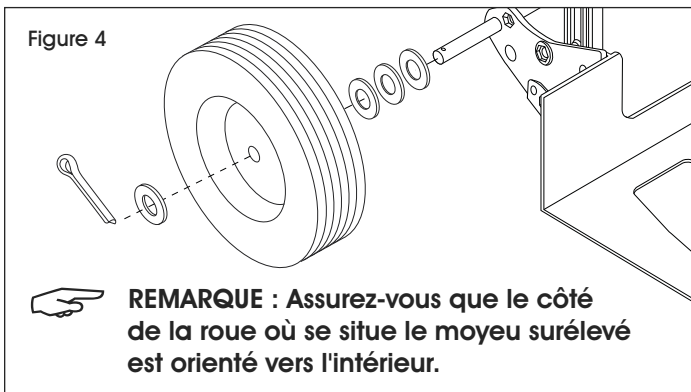

Figure 4

REMARQUE : Assurez-vous que le côté de la roue où se situe le moyeu surélevé est orienté vers l'intérieur.

REMARQUE : N'utilisez pas d'outils pneumatiques ou électriques.

FIXATION DE LA POIGNÉE

1. Dévissez et enlevez les boulons et les écrous freinés de 6 mm situés sur les glissières supérieures du cadre. Faites glisser la poignée dans le cadre. Alignez les trous de la poignée sur ceux du cadre. Enfilez les boulons à travers le cadre et la poignée et fixez-les avec les écrous freinés. (Voir Figure 1)

FIXATION DE LA BAVETTE ET DES SUPPORTS D'ESSIEU

1. Positionnez les renforts de cadre contre les glissières à l'extrémité inférieure du cadre. (Voir Figure 2a) Glissez la bavette dans la cannelure des renforts de cadre en gardant les trous de boulon alignés. (Voir Figure 2)
2. Alignez le support d'essieu avec la glissière extérieure du cadre. (Voir Figure 2)
3. Insérez quatre boulons de 8 mm à travers les supports d'essieu, le cadre, les renforts de cadre et la bavette. Fixez avec les écrous freinés, mais NE serrez PAS. (Voir Figure 2)

FIXATION DE L'ESSIEU ET DES ROUES

1. Posez le diable sur le devant de sorte que les supports d'essieu soient orientés vers le haut. (Voir Figure 3)



AVERTISSEMENT : Si vous voulez installer un monte-escalier, référez-vous aux instructions fournies avec l'accessoire et sautez l'étape 2. Une fois complété, passez à l'étape 3. Si vous n'installez pas de monte-escalier, passez à l'étape 2.

2. Enfilez l'essieu dans les trous supérieurs des supports d'essieu. Alignez les trous dans l'essieu avec les rainures à l'intérieur des supports d'essieu. Utilisez un marteau pour planter les goupilles. (Voir Figure 3a)
3. Enfilez trois rondelles à chaque extrémité de l'essieu. Enfilez une roue à chaque extrémité de l'essieu. Enfilez une autre rondelle à chaque extrémité de l'essieu. (Voir Figure 4)
4. Insérez une goupille fendue dans le trou à chaque extrémité de l'essieu. Repliez les goupilles à l'aide d'une pince afin de fixer les roues en place. Les roues doivent tourner librement. (Voir Figure 4)
5. Serrez tous les écrous freinés.

ULINE

1 800 295-5510
uline.ca