

ULINE H-3643 BIG AND TALL OFFICE CHAIR

1-800-295-5510
uline.com

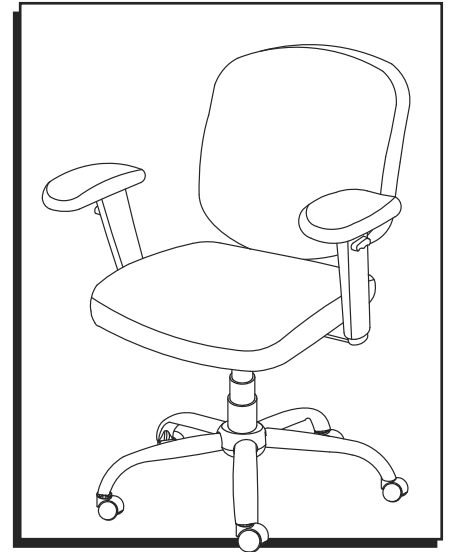





TOOL NEEDED

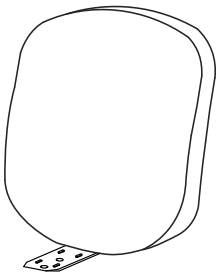

Allen Wrench
(included)

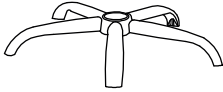
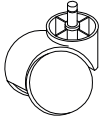
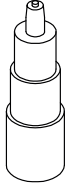
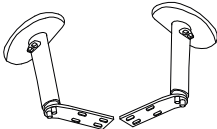
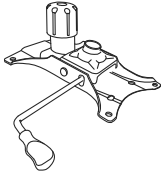
PARTS

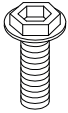
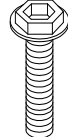
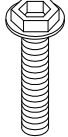
 Back Cushion x 1	 Seat Cushion x 1	 5-Star Base x 1	 Caster x 5	Hardware Kit	
	 Gas Lift x 1	 Armrest x 2	 Mechanism x 1	 Screw x 8 5/16 x 1 1/4"	 Screw x 4 5/16 x 1"
				 Screw x 2 3/8 x 1 1/2"	 Screw x 2 3/8 x 1 1/4"

ASSEMBLY

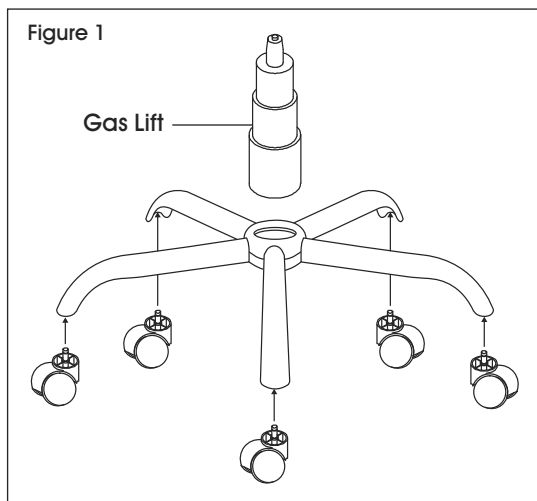

1. Insert casters into legs on five-star base. Turn base upright. Insert gas lift into center of base. (See Figure 1)

ASSEMBLY CONTINUED

Figure 2

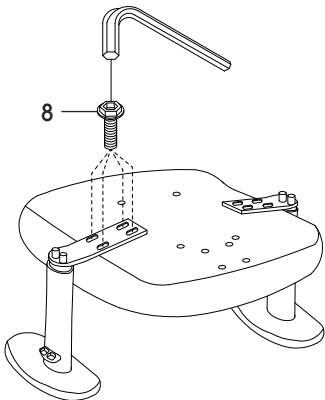

2. Align armrest with holes on bottom of seat cushion. Use four 5/16 x 1/4" screws (8) to attach. Repeat on opposite side. (See Figure 2)



NOTE: Use Allen wrench to tighten all screws.

Figure 3

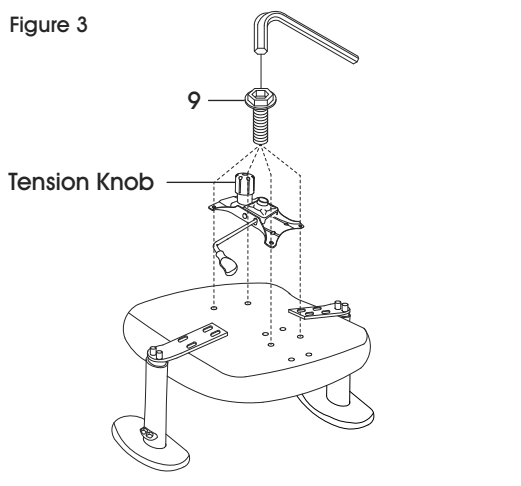

3. Align mechanism with holes on bottom of seat cushion with tension knob facing the front of seat. Use four 5/16 x 1" screws (9) to attach. (See Figure 3)

Figure 4

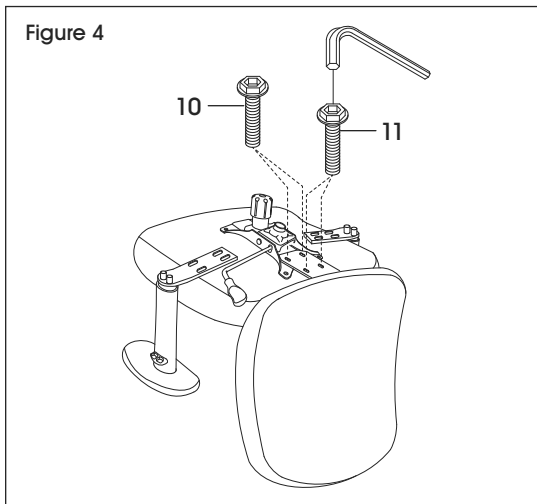

4. Align back cushion mounting plate with holes on bottom of seat cushion. Use two 3/8 x 1 1/2" screws (10) and two 3/8 x 1 1/4" screws (11) to attach. (See Figure 4)

ASSEMBLY CONTINUED

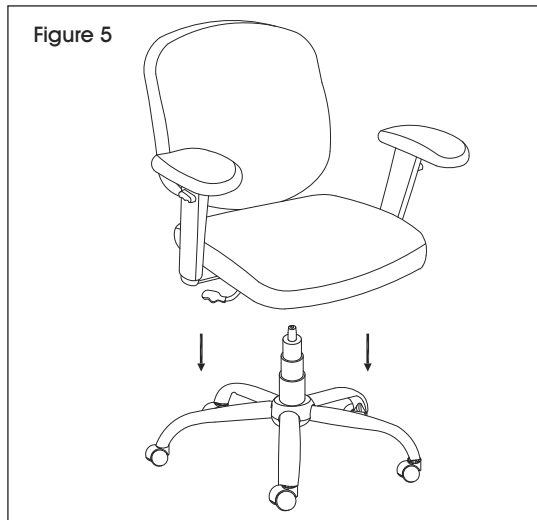

5. Slowly lower chair assembly onto the gas lift. Press down on seat cushion to secure. (See Figure 5)

CHAIR ADJUSTMENTS

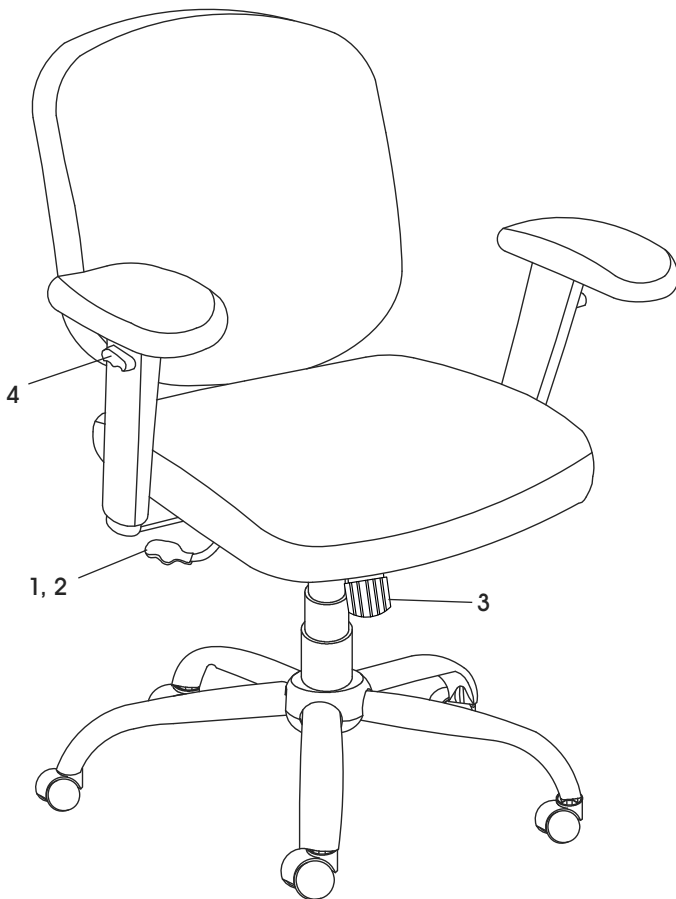

1. Seat Height Adjustment – To raise seat height, lift lever up with little to no weight on the seat. To lower seat height, lift lever up while sitting.
2. Upright Tilt Lock – To lock the chair in an upright position, push the lever in toward the center of the seat. To restore tilt, pull lever out. Chair has standard tilt; the seat and back tilt simultaneously at the same ratio.
3. Tilt Tension – To increase tilt tension, turn knob clockwise. To decrease tilt tension, turn knob counterclockwise.
4. Armrest Height Adjustment – To adjust arm height, press the button on the side of each armrest and move the armrest up or down.

ULINE

1-800-295-5510

uline.com

ULINE H-3643

SILLA GRANDE Y ALTA DE OFICINA

800-295-5510

uline.mx

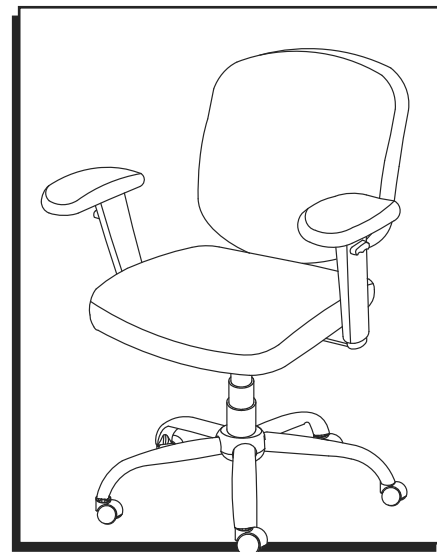



HERRAMIENTA NECESARIA

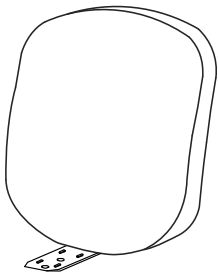

Llave Allen
(incluida)

PARTES

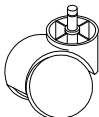
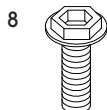
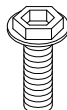
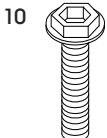
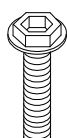
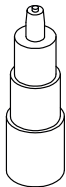
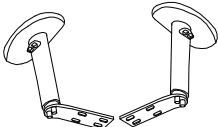
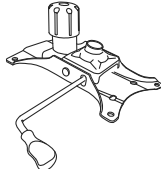
 1 Respaldo	 1 Asiento	 1 Base Estrella	 5 Ruedas	Kit de Tornillería  8 Tornillos 5/16 x 1 1/4"  4 Tornillos 5/16 x 1"  2 Tornillos 3/8 x 1 1/2"  2 Tornillos 3/8 x 1 1/4"	
 1 Pistón de Gas	 2 Descansabrazos	 1 Mecanismo			

ENSAMBLE

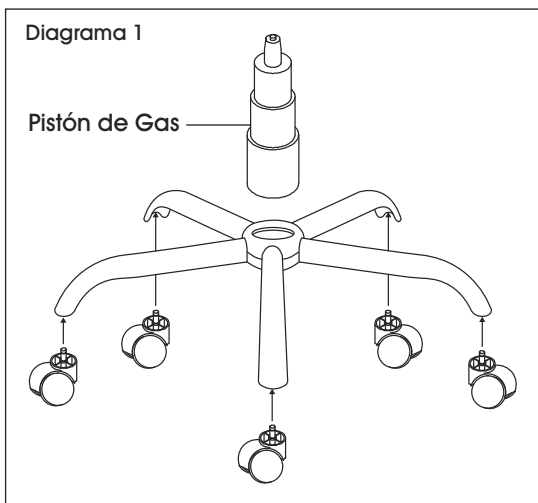

1. Inserte las ruedas en las patas de la base estrella. Enderece la base. Inserte el pistón de gas en el centro de la base. (Vea Diagrama 1)

CONTINUACIÓN DEL ENSAMBLE

Diagrama 2

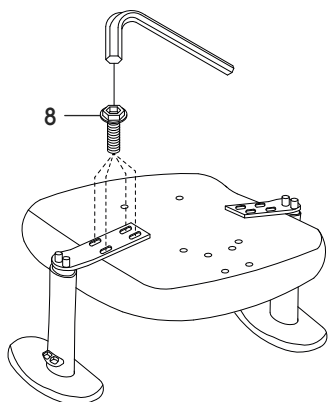

2. Alinee el descansabrazos con los orificios en la parte inferior del asiento. Use cuatro tornillos de $5/16 \times 1\frac{1}{4}$ " (8) para asegurarlo. Repita la operación con el lado opuesto. (Vea Diagrama 2)



NOTA: Utilice la llave Allen para apretar todos los tornillos.

Diagrama 3

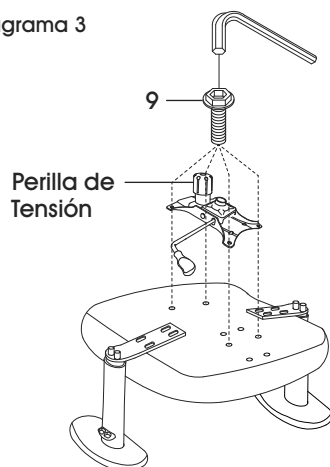

3. Alinee el mecanismo con los orificios en la parte inferior del asiento con la perilla de tensión volteando hacia la parte frontal del asiento. Use cuatro tornillos de $5/16 \times 1$ " (9) para fijarlo. (Vea Diagrama 3)

Diagrama 4

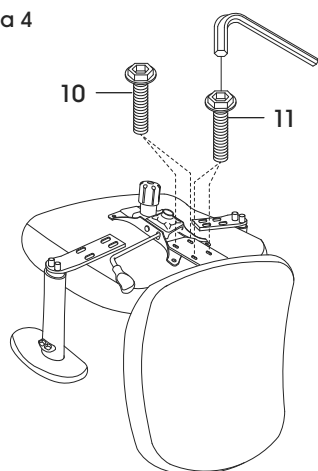

4. Alinee la placa de instalación para el respaldo con los orificios en la parte inferior del asiento. Use dos tornillos de $3/8 \times 1\frac{1}{2}$ " (10) y dos tornillos de $3/8 \times 1\frac{3}{4}$ " (11) para fijarlo. (Vea Diagrama 4)

CONTINUACIÓN DEL ENSAMBLE

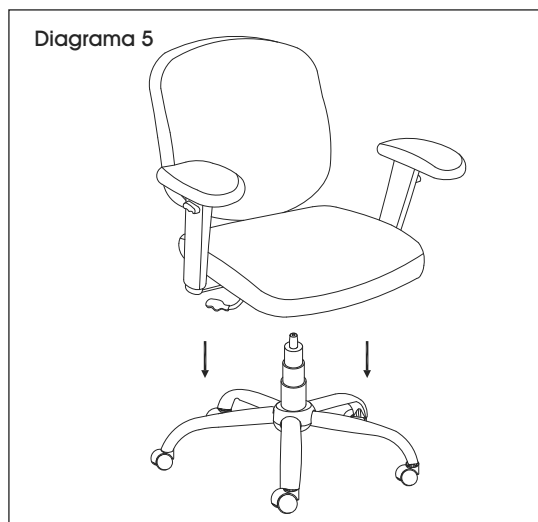

5. Baje lentamente el ensamble de la silla sobre el pistón de gas. Presione el asiento para asegurarlo. (Vea Diagrama 5)

AJUSTES DE LA SILLA

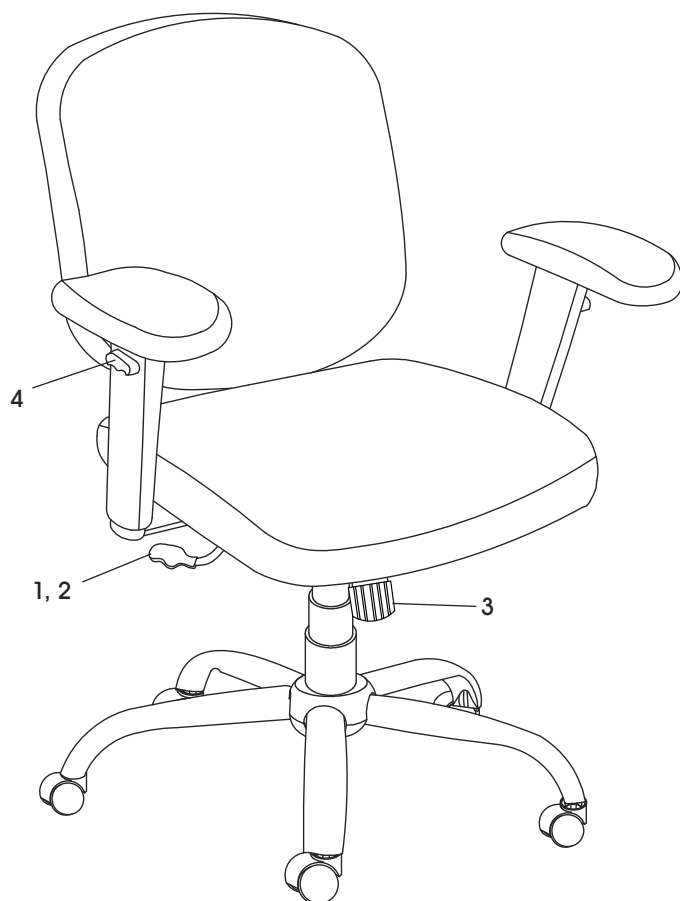

1. Ajuste de la Altura del Asiento – Para subir la altura del asiento, levante la palanca sin o con poco peso en el asiento. Para bajar la altura del asiento, levante la palanca mientras está sentado.
2. Bloqueo de la Inclinación del Poste – Para bloquear la silla en una posición vertical, empuje la palanca hacia el centro del asiento. Para restaurar la inclinación, jale la palanca hacia afuera. La silla tiene una inclinación estándar, el asiento y el respaldo se inclinan simultáneamente en la misma proporción.
3. Tensión de Inclinación – Para aumentar la tensión de la inclinación, gire la perilla en el sentido de las manecillas del reloj. Para disminuir la tensión de la inclinación, gire la perilla en el sentido contrario de las manecillas del reloj.
4. Ajuste de la Altura de los Descansabrazos – Para ajustar la altura de los descansabrazos, presione el botón en el lateral de cada uno de ellos y muévalos hacia arriba o hacia abajo.

ULINE

800-295-5510
uline.mx

ULINE H-3643

CHAISE DE BUREAU POUR TAILLES FORTES ET ÉLANCÉES

1-800-295-5510
uline.ca

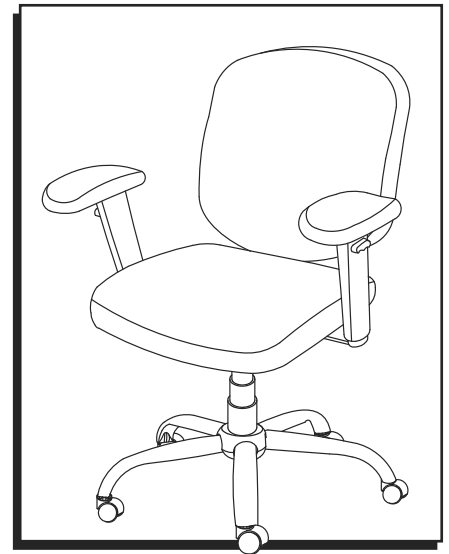

OUTIL REQUIS



Clé Allen
(inclus)

PIÈCES

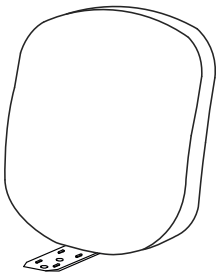
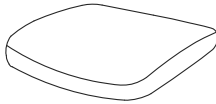
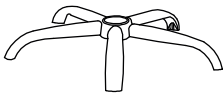
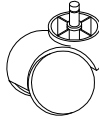
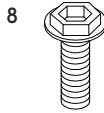
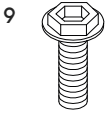
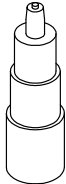
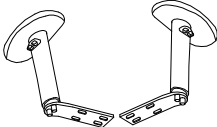
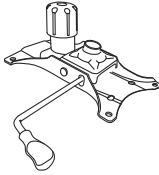
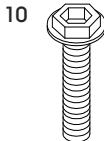
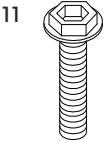
				Matériel d'installation	
Dossier x 1	Siège x 1	Base à 5 branches x 1	Roulette x 5		
					
	Vérin pneumatique x 1	Accoudoir x 2	Mécanisme x 1	Vis x 2 3/8 x 1 1/2 po	Vis x 4 5/16 x 1 po

ASSEMBLAGE

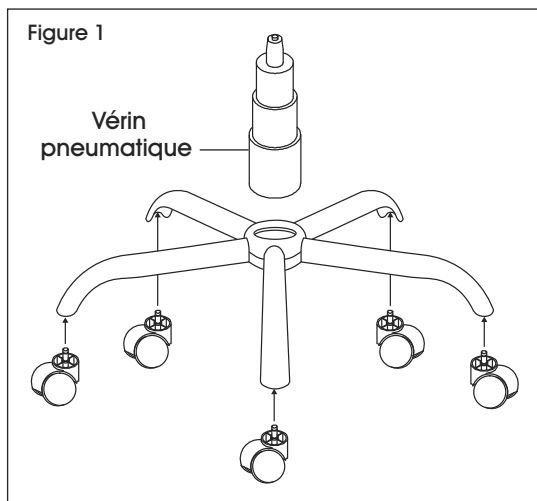

1. Insérez les roulettes dans les pieds de la base à cinq branches. Tournez la base à l'endroit. Insérez le vérin pneumatique dans le centre de la base. (Voir Figure 1)

ASSEMBLAGE (SUITE)

Figure 2

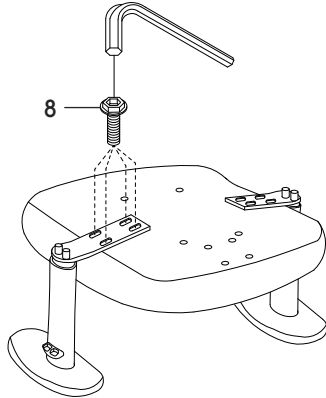

2. Alignez l'accoudoir sur les trous situés sous le siège. Fixez-le avec quatre vis de 5/16 x 1 1/4 po (8). Répétez la procédure de l'autre côté. (Voir Figure 2)



REMARQUE : Utilisez la clé Allen pour serrer toutes les vis.

Figure 3

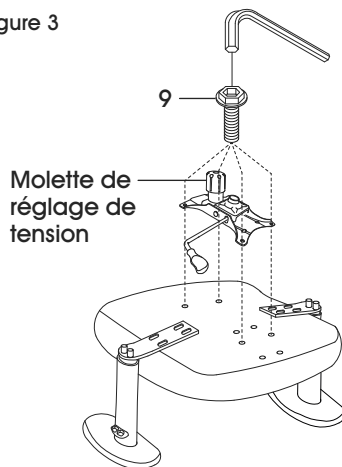

3. Alignez le mécanisme sur les trous situés sous le siège en orientant la molette de réglage de tension vers l'avant du siège. Fixez-le avec quatre vis de 5/16 x 1 po (9). (Voir Figure 3)

Figure 4

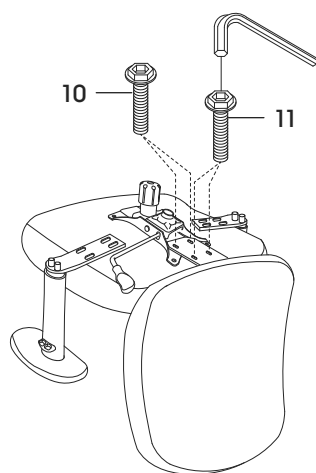

4. Alignez la plaque de montage du dossier sur les trous situés sous le siège. Fixez-la avec deux vis de 3/8 x 1 1/2 po (10) et deux vis de 3/8 x 1 1/4 po (11). (Voir Figure 4)

ASSEMBLAGE (SUITE)

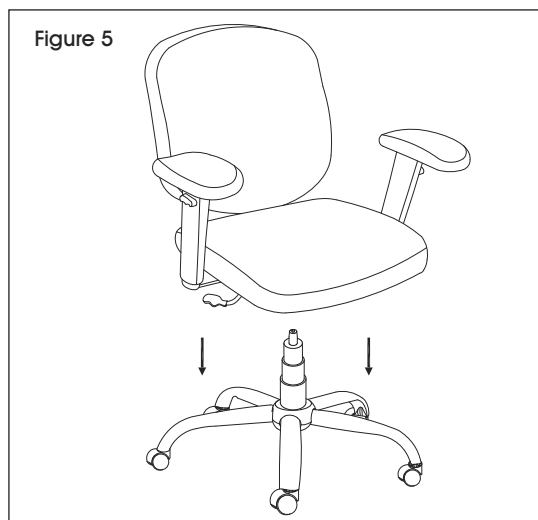

5. Abaissez lentement la chaise sur le vérin pneumatique. Appuyez sur le siège pour le fixer. (Voir Figure 5)

RÉGLAGES DE LA CHAISE

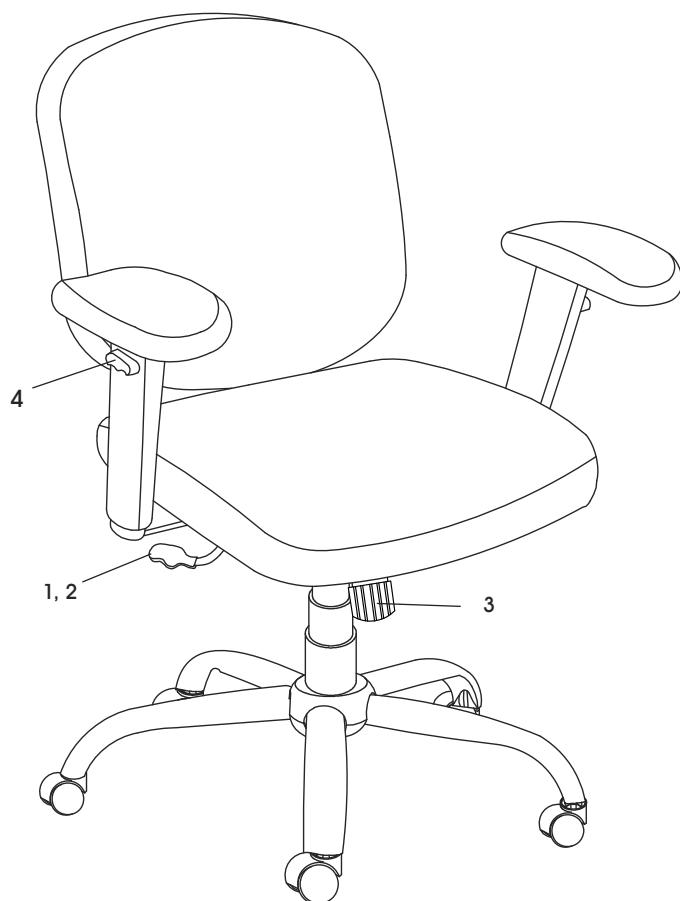

1. Réglage de la hauteur du siège – Pour élever le siège, soulevez le levier avec peu ou sans poids sur le siège. Pour abaisser le siège, soulevez le levier en position assise.
2. Inclinaison avec blocage en position verticale – Pour bloquer la chaise en position verticale, poussez le levier vers le centre du siège. Pour rétablir l'inclinaison, tirez le levier vers l'extérieur. La chaise comporte une inclinaison standard; le siège et le dossier s'inclinent au même degré simultanément.
3. Tension d'inclinaison – Pour augmenter la tension d'inclinaison, tournez la molette dans le sens horaire. Pour diminuer la tension d'inclinaison, tournez la molette dans le sens antihoraire.
4. Réglage de la hauteur des accoudoirs – Pour régler les accoudoirs en hauteur, appuyez sur le bouton situé sur le côté de chacun des accoudoirs, puis faites bouger ceux-ci vers le haut ou vers le bas.

ULINE

1-800-295-5510
uline.ca