

# ULINE H-3789 SPIRAL CLOTHES RACK

1-800-295-5510  
uline.com

Para Español, vea páginas 3-4.  
Pour le français, consulter les pages 5-6.

## TOOLS INCLUDED



Large Allen Wrench



Small Allen Wrench

## RECOMMENDED TOOL

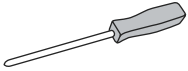

Phillips Screwdriver

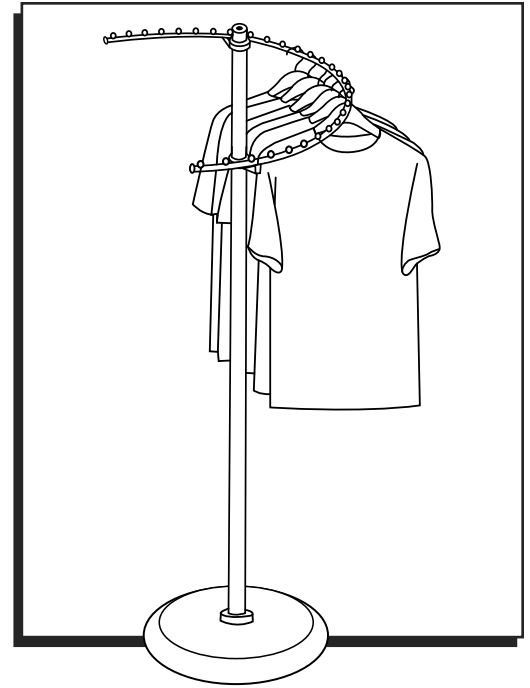

## PARTS



Bottom Post x 1  
(Bolt & Lock Washer Attached)

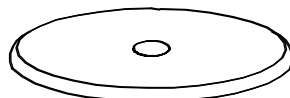

Base x 1



Large Allen Wrench x 1



Collar x 1



Small Allen Wrench  
x 1

Red Hardware Bag



Top Post x 1

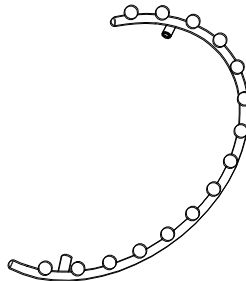

Spiral Tube x 1  
(2 End Caps Attached)

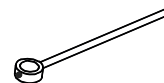

Spacer x 2  
(Screw and Headless  
Screw Attached)

# ASSEMBLY

1. Remove bolt and lock washer from bottom post. Connect bottom post to base using bolt, lock washer and collar. Tighten with large Allen wrench. (See Figure 1)

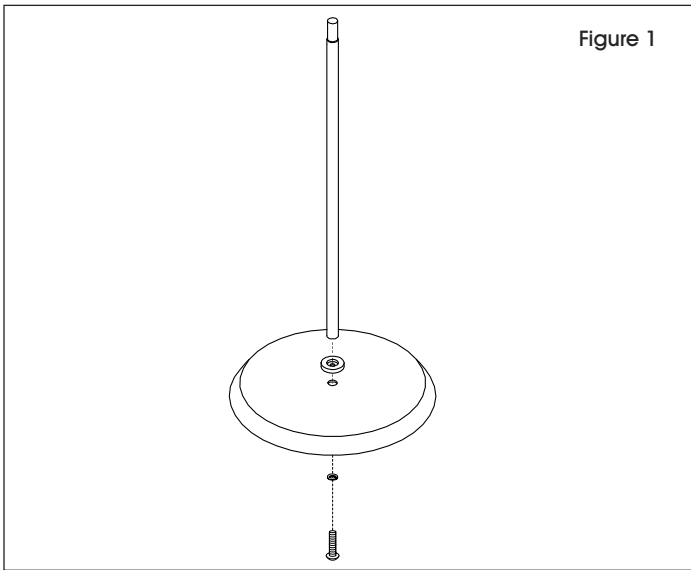

2. Slide top post over bottom post. Twist in place to tighten. (See Figure 2)

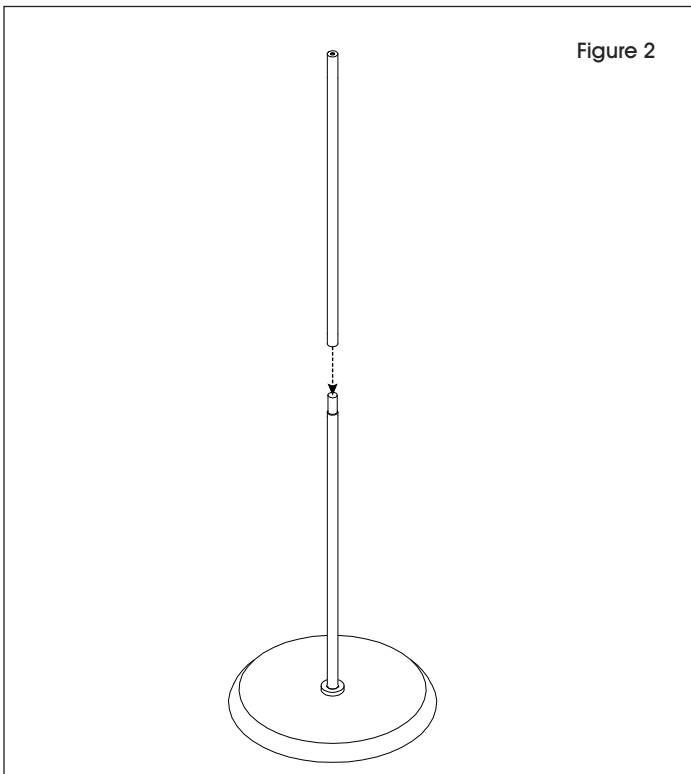

3. Unscrew two screws from straight end of spacers. Attach spacers to spiral tube using two screws. (See Figure 3)

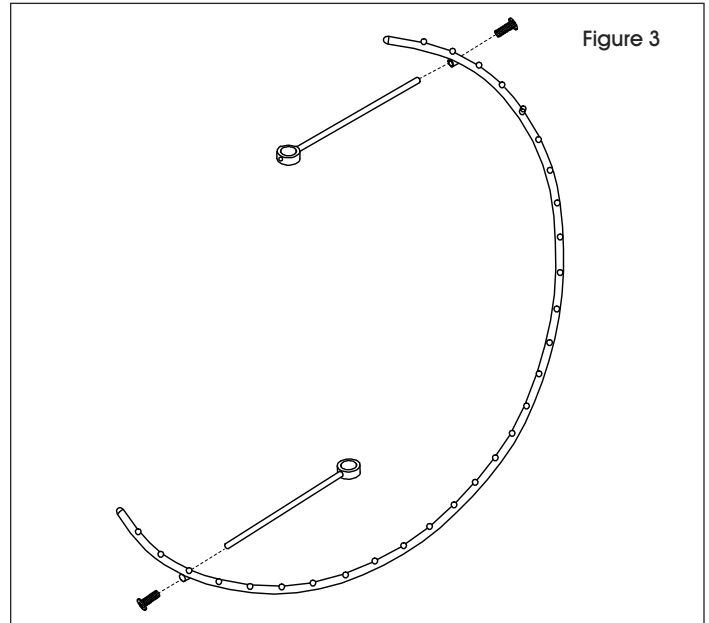

4. Unscrew two headless screws from ringed end of spacers. Slide spacers and spiral tube over top post. Secure headless screws using small Allen wrench. (See Figure 4)

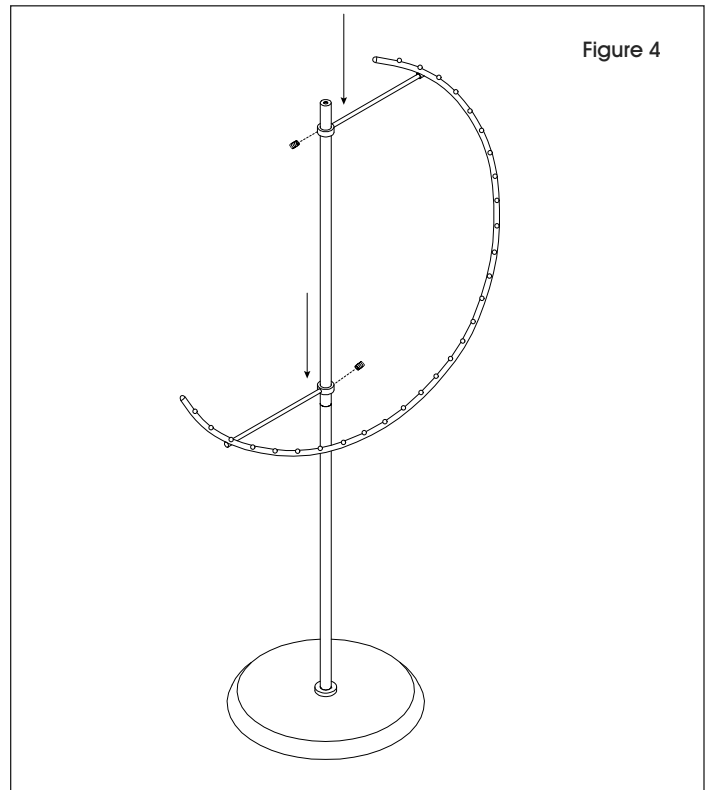

**ULINE**

1-800-295-5510  
uline.com

# ULINE H-3789 RACK EN ESPIRAL PARA ROPA

800-295-5510  
uline.mx

## HERRAMIENTAS INCLUIDAS



Llave Allen Grande



Llave Allen Pequeña

## HERRAMIENTA RECOMENDADA

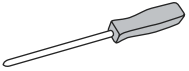

Desarmador Phillips

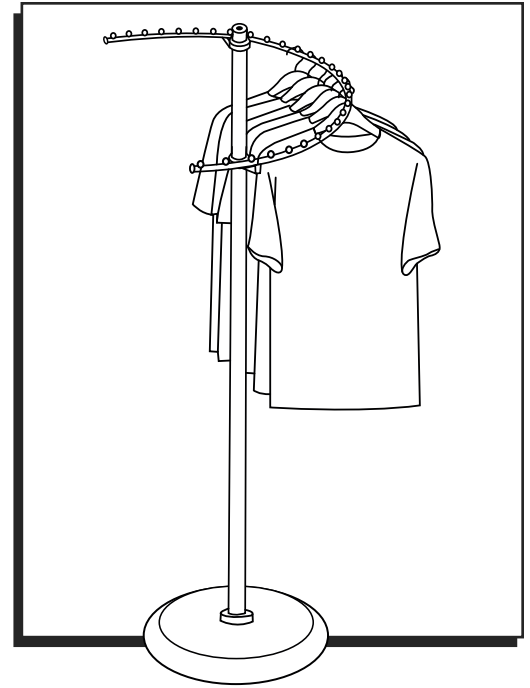

## PARTES



1 Poste Inferior  
(Perno y Arandela de Presión Adjuntas)

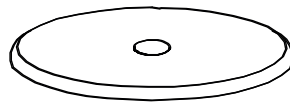

1 Base



1 Llave Allen Grande



1 Collarín



1 Llave Allen Pequeña

Bolsa Roja con Herrajes



1 Poste Superior

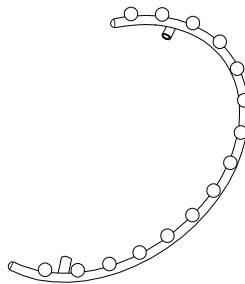

1 Tubo en Espiral  
(2 Tapas Adjuntas)

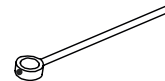

2 Espaciadores  
(Tornillo y Tornillo Plano Adjuntos)

# ENSAMBLE

1. Remueva el perno y la arandela de presión del poste inferior. Conecte el poste inferior a la base usando el perno, la arandela de presión y el collarín. Apriete con la llave Allen grande. (Vea Diagrama 1)

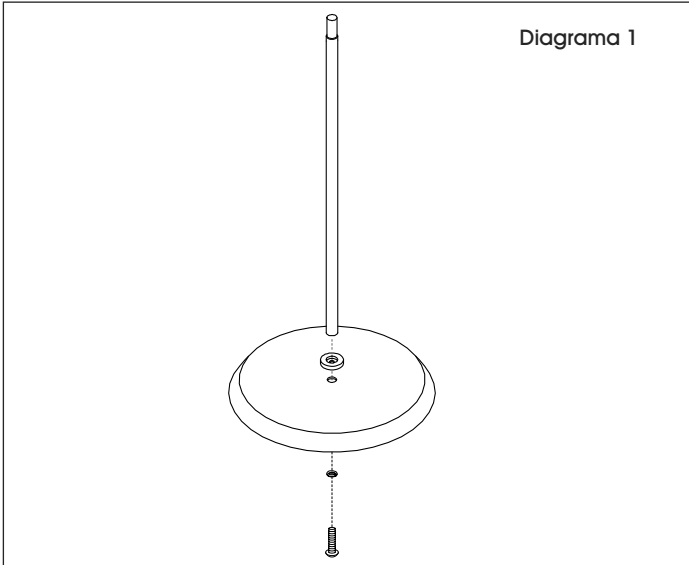

2. Deslice el poste superior sobre el inferior. Enrosque para apretar. (Vea Diagrama 2)

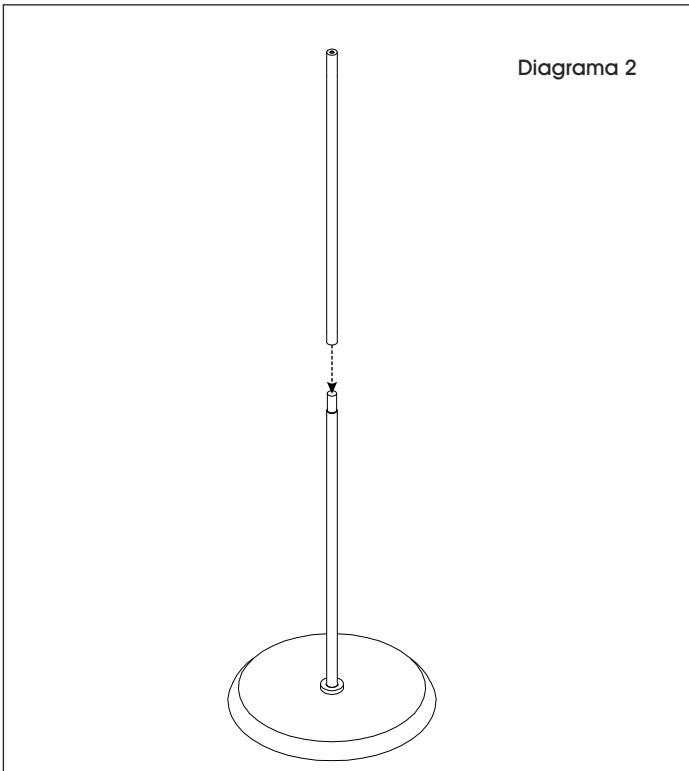

3. Desatornille dos tornillos del extremo recto de los espaciadores. Acople los espaciadores al tubo en espiral usando los dos tornillos. (Vea Diagrama 3)

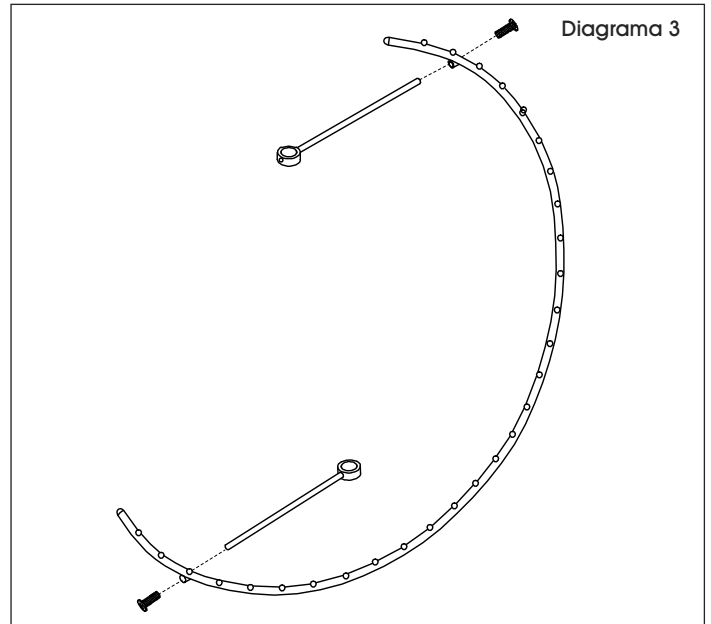

4. Desatornille dos tornillos sin cabeza del extremo anillado de los espaciadores. Deslice los espaciadores y el tubo espiral sobre el poste superior. Asegure los tornillos planos usando la llave Allen pequeña. (Vea Diagrama 4)

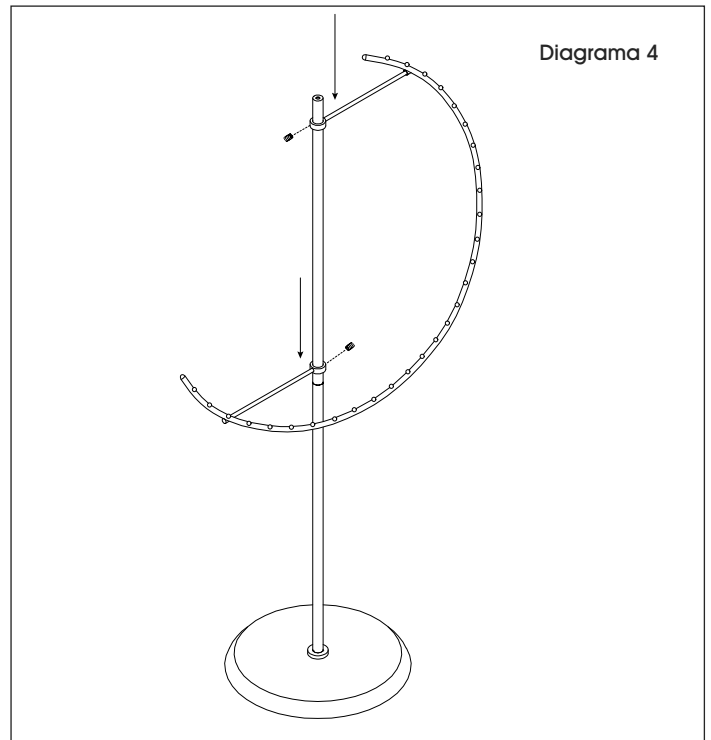

**ULINE**

800-295-5510  
uline.mx

**ULINE** H-3789

# SUPPORT À VÊTEMENTS EN SPIRALE

1-800-295-5510  
uline.ca

## OUTILS INCLUS

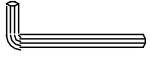

Grande clé Allen



Petite clé Allen

## OUTIL RECOMMANDÉ

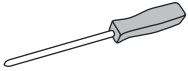

Tournevis Phillips

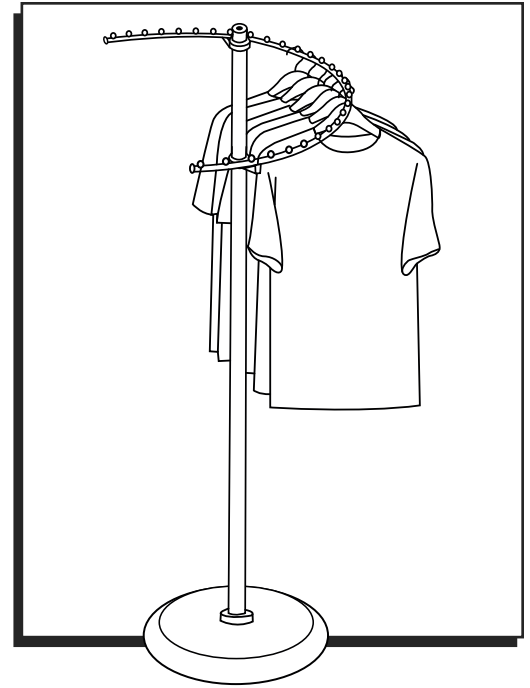

## PIÈCES



Poteau inférieur x 1  
(boulon et rondelle de blocage inclus)

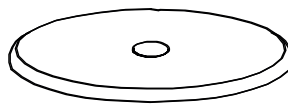

Base x 1



Grande clé Allen x 1



Collet x 1



Petite clé Allen x 1

Sac de quincaillerie rouge

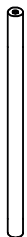

Poteau supérieur x 1

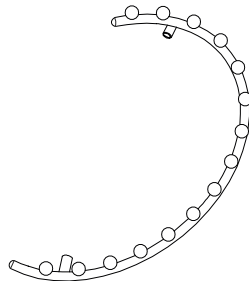

Tube en spirale x 1  
(2 capuchons d'extrémité inclus)

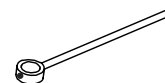

Séparateurs x 2  
(vis et vis sans tête incluses)

## ASSEMBLAGE

1. Retirez le boulon et la rondelle de blocage du poteau inférieur. Fixez le poteau inférieur à la base à l'aide du boulon, de la rondelle de blocage, de la rondelle plate et du collet. Serrez l'ensemble avec la grande clé Allen. (Voir Figure 1)

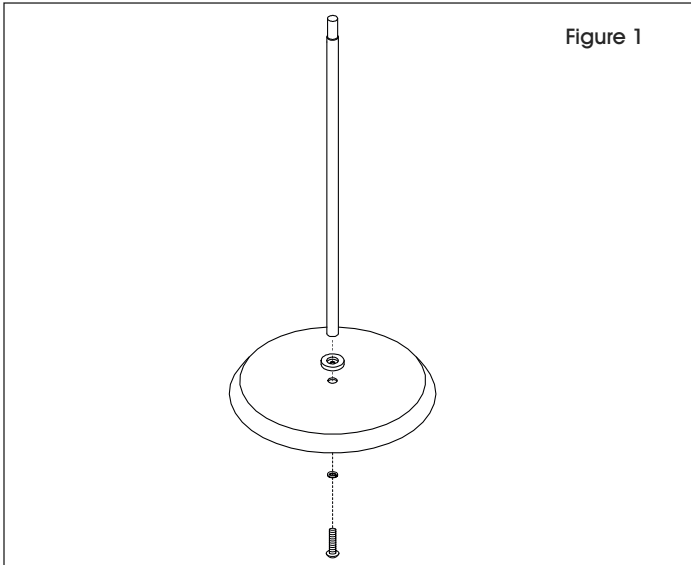

2. Glissez le poteau supérieur sur le poteau inférieur. Tournez-le pour le serrer. (Voir Figure 2)

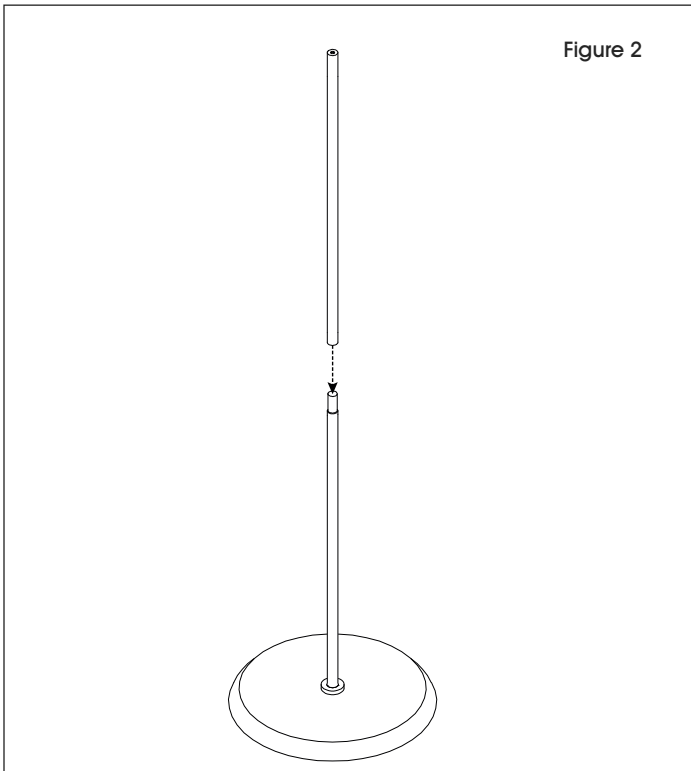

3. Dévissez les vis de l'extrémité linéaire des séparateurs. Fixez les séparateurs au tube en spirale à l'aide des deux vis. (Voir Figure 3)

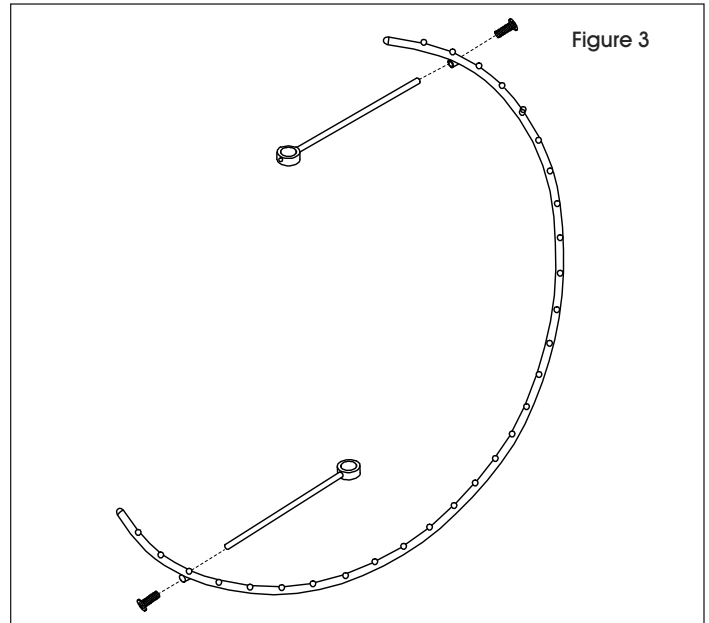

4. Dévissez les deux vis sans tête de l'extrémité annelée des séparateurs. Glissez les séparateurs et le tube en spirale sur le poteau supérieur. Serrez les vis sans tête avec la petite clé Allen. (Voir Figure 4)

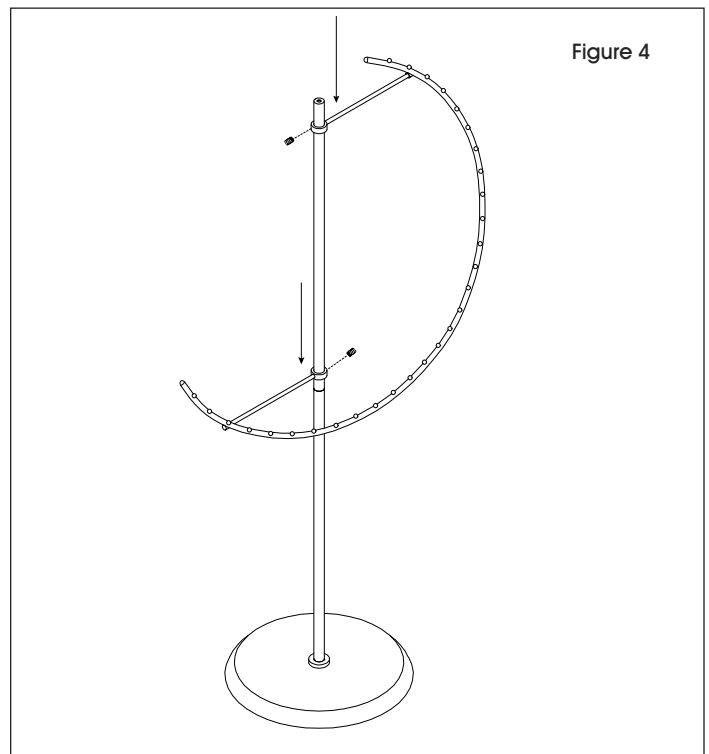

**ULINE**

1-800-295-5510  
uline.ca