

ULINE

MOBILE PANEL ORGANIZER

1-800-295-5510
uline.com

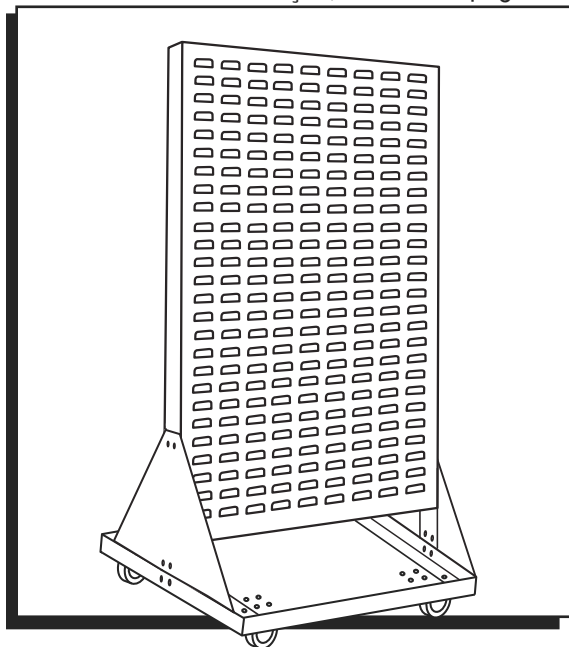

TOOLS NEEDED

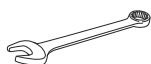

10mm
Wrench

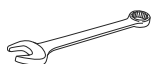

11mm
Wrench

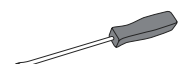

Flat Head
Screwdriver

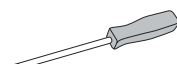

Phillips
Screwdriver

PANEL ASSEMBLY

PARTS LIST

- Louvered Panel x 1
- Side Support Panels x 2
- Bolts x 12
- Nuts x 8

1. Take Louvered Panel (A) and line up holes (B) (stamped into the left and right side of the panel) to matching holes (C) stamped into each side support panel.
2. Attach Louvered Panel to Side Supports using eight (8) bolts and four (4) nuts included with the unit. (Top 2 bolts on each end of the panel screw in without nuts.)



NOTE: Leave the bottom 2 bolts and nuts on each end of the panel out for this step. These will be used later to attach mobile base.

Figure 1

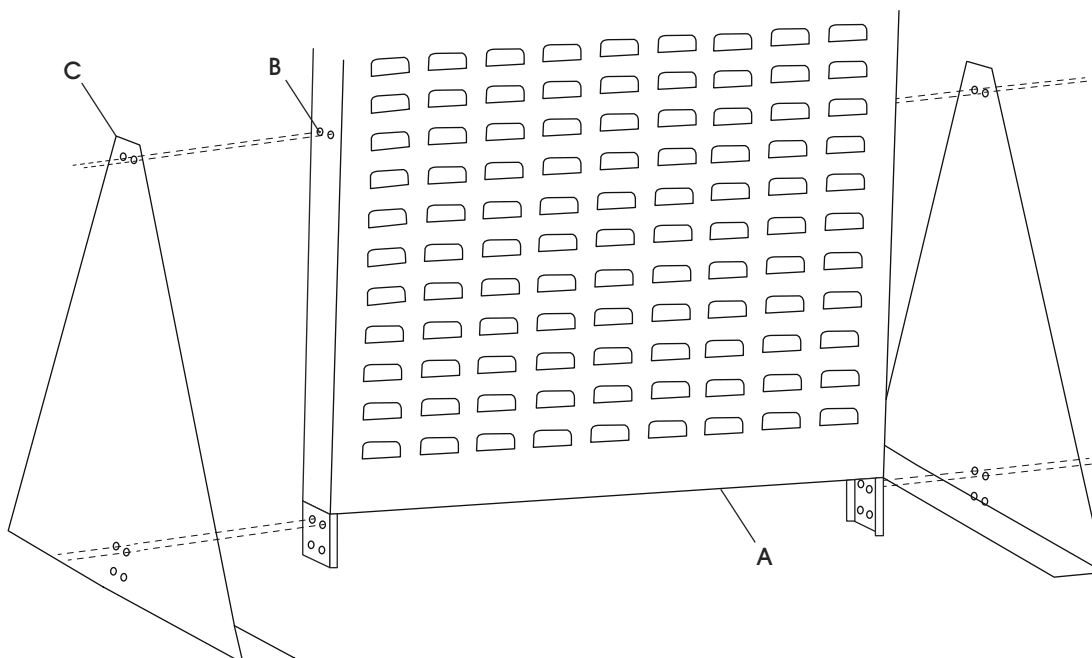

MOBILE BASE PARTS LIST

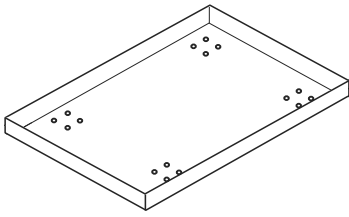

Deck x 1



Swivel Caster x 2

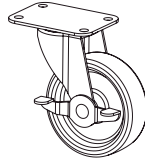

Locking Swivel Caster x 2

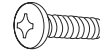

Bolt x 28



Locknut x 12



Nut x 16



Washer x 28



Lock Washer x 16



MOBILE BASE ASSEMBLY

Figure 2

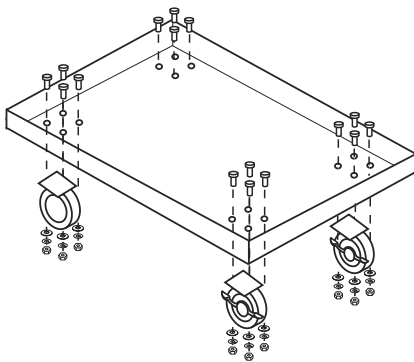

NOTE: There may be hardware left over after assembly as this mobile base is used for multiple products.

1. Attach two swivel casters to one end of the deck using eight bolts, nuts, washers and lock washers. Attach the locking swivel casters to the other end. (See Figure 2)



NOTE: Casters should be attached to the flat side of the deck (side without lip).

PANEL TO BASE ASSEMBLY

Figure 3

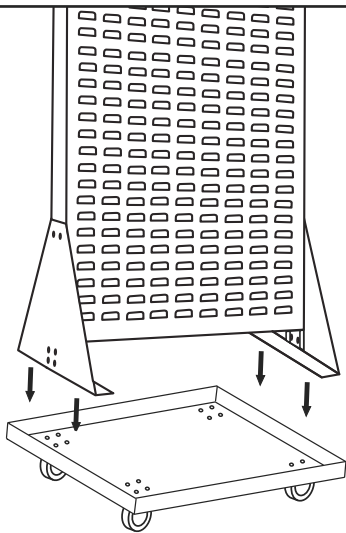
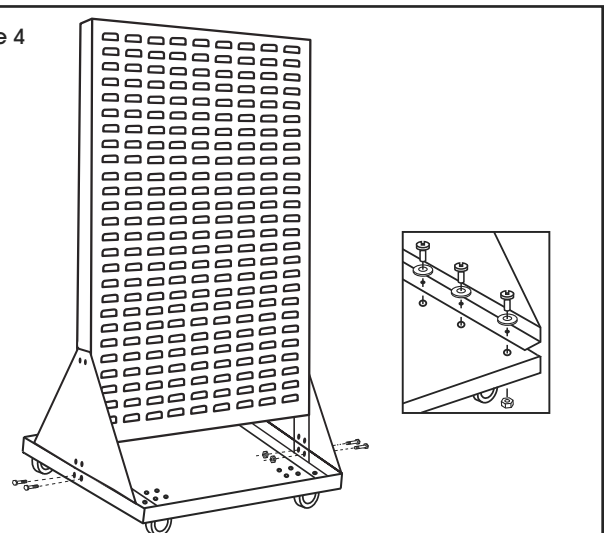

Figure 4



1. With the mobile base rightside up, engage the locks on the locking swivel casters. Lift and place panel rack onto mobile base. (See Figure 3)
2. Using the remaining 4 bolts and nuts included with the panel, attach Panel Rack to the lip of the mobile base. Then attach Panel Rack to the deck of the mobile base by using 12 bolts, washers and locknuts. (See Figure 4)

ULINE

1-800-295-5510

uline.com

ULINE

ORGANIZADOR DE PANELES MÓVIL

800-295-5510

uline.mx

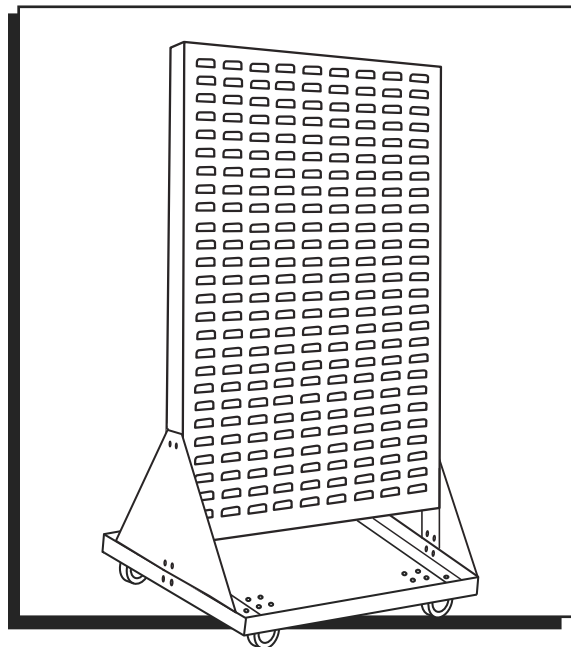

HERRAMIENTAS NECESARIAS



Llave de 10 mm

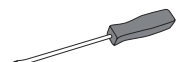
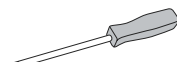

Llave de 11 mm

Desarmador
PlanoDesarmador
Phillips

ENSAMBLE DEL PANEL

LISTA DE PARTES

- 1 Panel de Rejillas
- 2 Paneles de Soporte Laterales
- 12 Pernos
- 8 Tuercas

1. Tome el panel de rejillas (A) y alinee los orificios (B) (estampados en los lados derecho e izquierdo del panel) con los orificios coincidentes (C) estampados en cada uno de los paneles de soporte laterales.
2. Fije el panel de rejillas a los soportes laterales usando los ocho (8) pernos y las cuatro (4) tuercas que se incluyen con la unidad. (Los 2 pernos superiores de cada uno de los extremos del panel se enroscan sin tuercas).



NOTA: En este paso, haga caso omiso de los 2 pernos y tuercas inferiores en cada uno de los extremos del panel. Estos se utilizarán más tarde para fijar la base móvil.

Diagrama 1

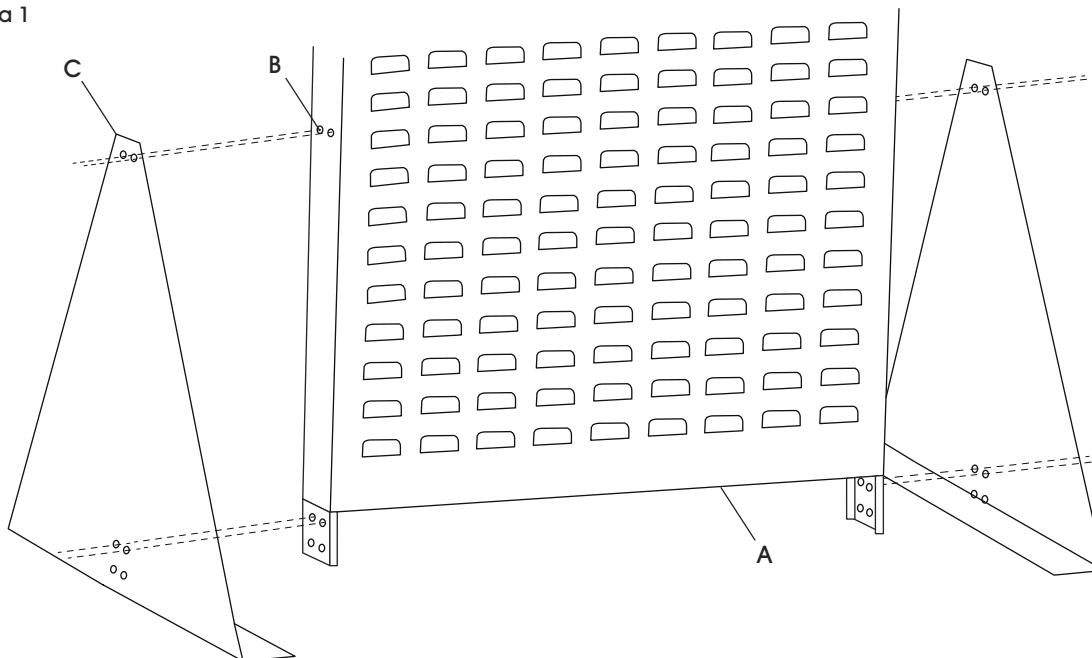

LISTA DE PARTES DE LA BASE MÓVIL

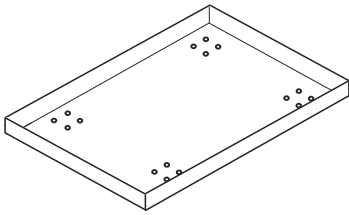

1 Plataforma

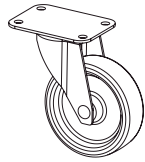

2 Ruedas Giratorias

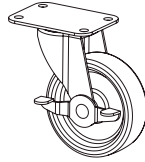

2 Ruedas Giratorias con Seguro



28 Pernos



12 Tuercas de Seguridad



16 Tuercas



28 Rondanas



16 Rondanas de Seguridad



ENSAMBLE DE LA BASE MÓVIL

Diagrama 2

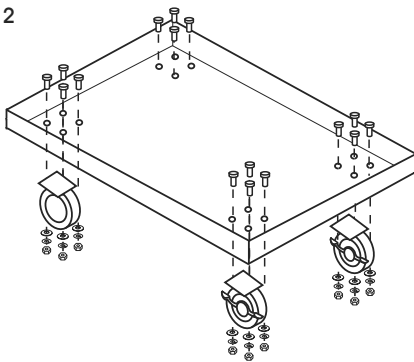

NOTA: Puede que le sobre tornillería tras el ensamble, puesto que esta base móvil se usa para varios productos.

1. Fije 2 ruedas giratorias a uno de los extremos de la plataforma usando 8 pernos, tuercas, rondanas y rondanas de seguridad. Fije las ruedas giratorias con seguro al otro extremo. (Vea Diagrama 2)



NOTA: Las ruedas deben colocarse en el lado plano de la plataforma (el lado sin borde).

ENSAMBLE DEL PANEL A LA BASE

Diagrama 3

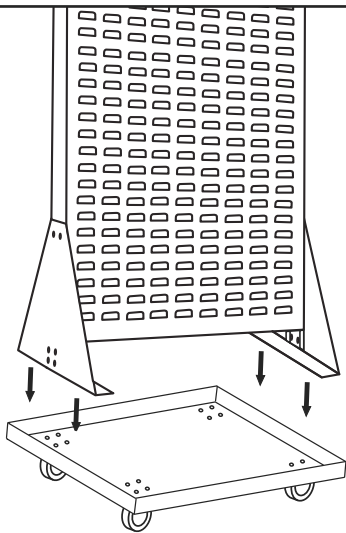

1. Con la plataforma móvil mirando hacia arriba, active los seguros de las ruedas giratorias. Levante y coloque el rack tipo panel sobre la plataforma. (Vea Diagrama 3)

Diagrama 4

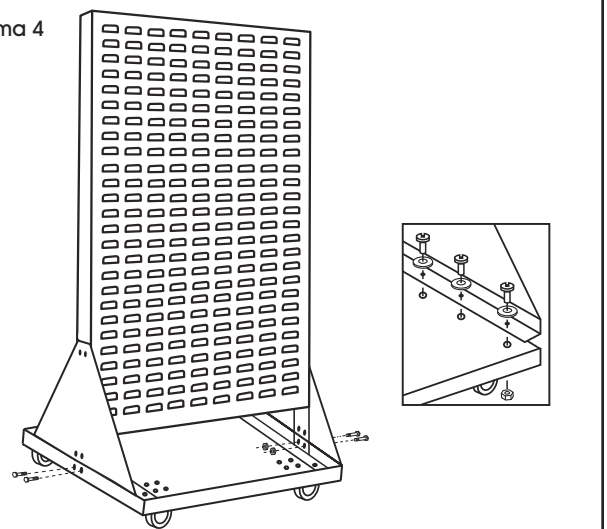

2. Usando los 4 pernos y tuercas restantes que se incluyen con el panel, fije el rack tipo panel al borde de la plataforma. Luego fije el rack tipo panel a la plataforma de la base móvil usando 12 pernos, rondanas y tuercas de seguridad. (Vea Diagrama 4)

ULINE

800-295-5510

uline.mx

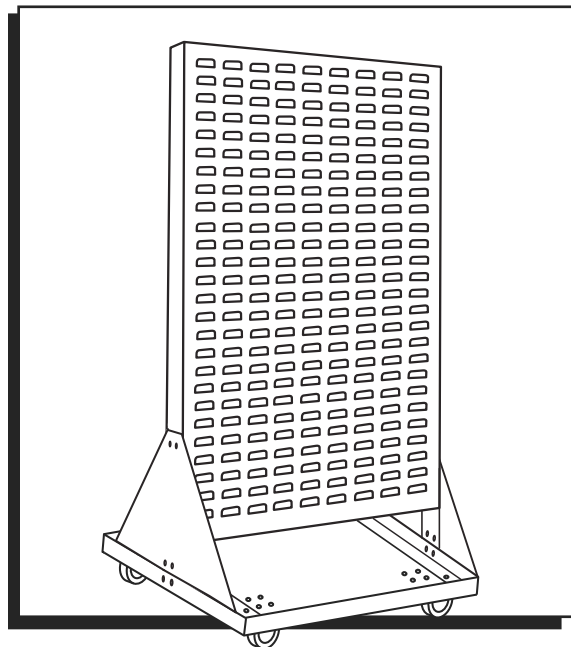
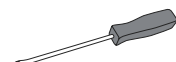
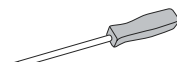
**OUTILS REQUIS**Clé de
10 mmClé de
11 mmTournevis à tête
plateTournevis
cruciforme**ASSEMBLAGE DU PANNEAU****LISTE DES PIÈCES**

- Panneau à fentes x 1
- Panneaux de support latéraux x 2
- Boulons x 12
- Écrous x 8

1. Prenez le panneau à fentes (A) et alignez les trous (B) (percés sur les côtés gauche et droit du panneau) avec les trous correspondants (C) percés sur chaque panneau de support latéral.
2. Fixez le panneau à fentes aux supports latéraux à l'aide de huit (8) boulons et quatre (4) écrous compris avec l'unité. (Les deux boulons supérieurs à chaque extrémité du panneau se vissent sans écrous.)



REMARQUE : Pour cette étape, laissez de côté les deux boulons et écrous inférieurs de chaque extrémité du panneau. Ceux-ci seront utilisés ultérieurement pour fixer le socle mobile.

Figure 1

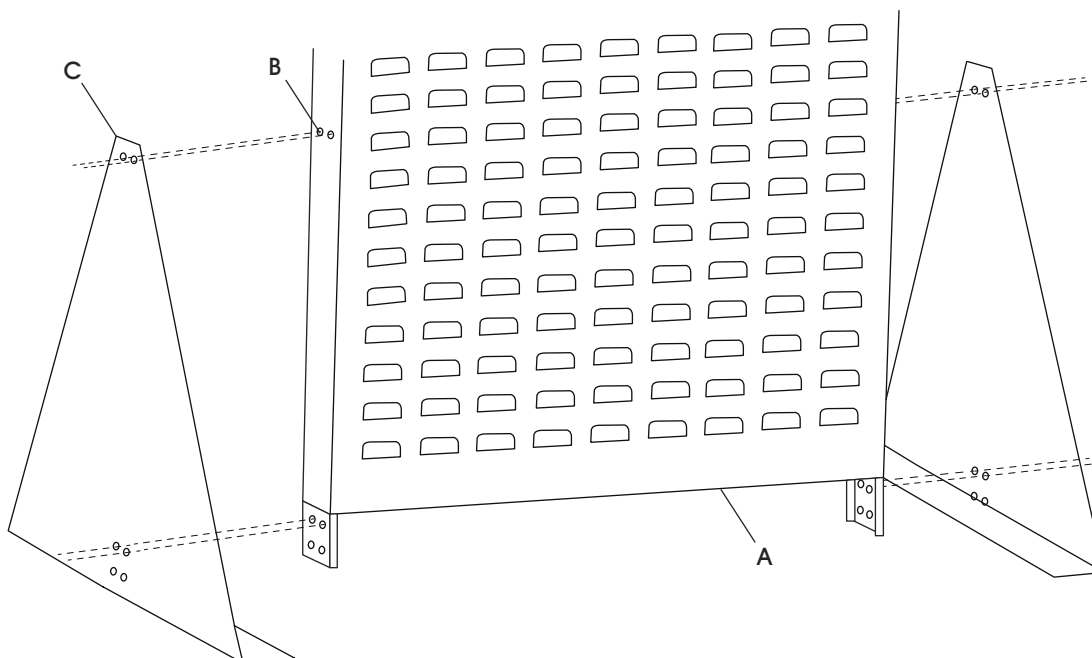

LISTE DES PIÈCES DU SOCLE MOBILE

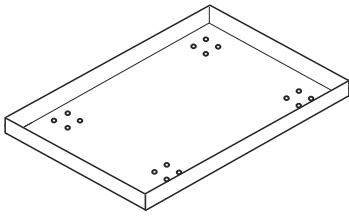

Plateau x 1

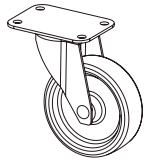

Roulette pivotante x 2

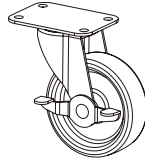

Roulette pivotante
verrouillable x 2

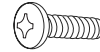

Boulon x 28



Écrou freiné x 12



Écrou x 16



Rondelle x 28



Rondelle de
blocage x 16



ASSEMBLAGE DU SOCLE MOBILE

Figure 2

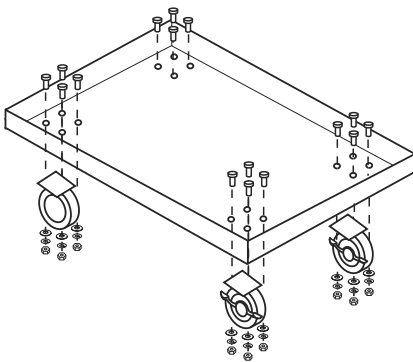

REMARQUE : Comme ce socle mobile est employé pour plusieurs produits, il se peut qu'il reste un surplus de matériel après l'assemblage.

1. Fixez deux roulettes pivotantes à une extrémité du plateau à l'aide de huit boulons, écrous, rondelles et rondelles de blocage. Fixez les roulettes pivotantes verrouillables à l'autre extrémité. (Voir Figure 2)



REMARQUE : Les roulettes doivent être fixées sur le côté plat du plateau (côté sans rebord).

ASSEMBLAGE DU PANNEAU AU SOCLE

Figure 3

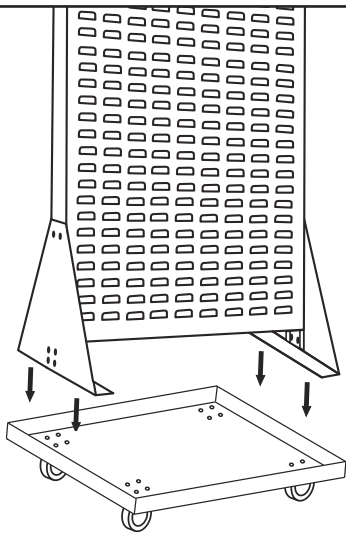
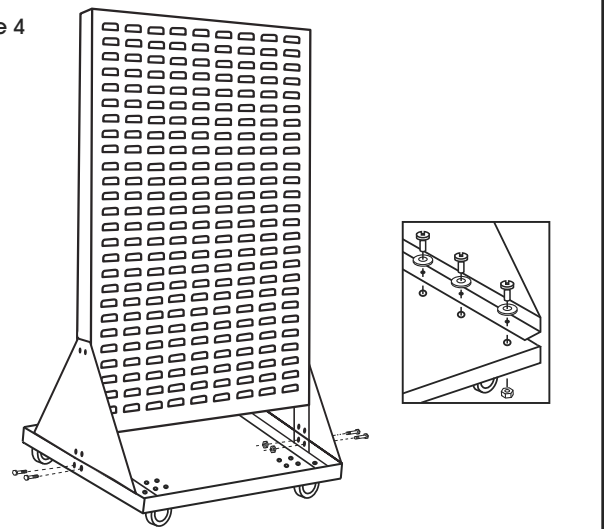

Figure 4



1. Avec le socle mobile à l'endroit, enclenchez le frein des roulettes pivotantes verrouillables. Soulevez et placez l'ensemble panneau et supports sur le socle mobile. (Voir Figure 3)

2. À l'aide des quatre autres boulons et écrous compris avec le panneau, fixez l'ensemble panneau et supports sur le rebord du socle mobile. Ensuite, fixez l'ensemble panneau et supports sur le plateau du socle mobile à l'aide de 12 boulons, rondelles et écrous freinés. (Voir Figure 4)

ULINE

1-800-295-5510
uline.ca