

# **Presto** LIFTS **ECO A**

## PPS2200-62NAS Owner's Manual

For PPS2200-62 NAS machines with frame numbers beginning with ST stamped into the mast.



Model: \_\_\_\_\_  
Serial Number: \_\_\_\_\_  
Date placed in service: \_\_\_\_\_

Presto Lifts Inc., 2 Hampshire Street, Suite 102, Foxborough, MA 02035  
800.343.9322 | Fax: 888.788.6496  
service@prestolifts.com  
www.PrestoLifts.com

**ULINE**

1-800-295-5510  
uline.com

# Contents

<b>1. Introduction.....</b>	<b>4</b>
1.1 Responsibilities of Owner and Users.....	4
1.2 Responsibilities of Operators .....	5
<b>2. Safety .....</b>	<b>7</b>
2.1 Safety Alert Symbols .....	7
2.2 Signal Words .....	7
<b>3. Labeling.....</b>	<b>10</b>
3.1 Label Placement Diagram .....	10
<b>4. Setup.....</b>	<b>11</b>
4.1 Critical Procedure for Proper Wheel Traction .....	11
4.2 Inspection .....	12
4.3 Removing From Pallet .....	12
4.4 Preparation For Use.....	12
4.5 Individual Fork Angle/Deflection Adjustment.....	13
<b>5. Operation.....</b>	<b>15</b>
5.1 To Raise and Lower .....	15
5.2 Travel Function.....	15
5.3 Turtle Speed Travel .....	15
5.4 Electric Brake .....	16
5.5 Reversing Safety .....	16
5.6 Horn.....	16
5.7 Fork Angle Adjustment.....	16
<b>6. Maintenance &amp; Repair .....</b>	<b>16</b>
6.1 Battery Maintenance .....	17
6.2 Periodic Maintenance .....	18
6.2.1 Weekly Maintenance.....	18
6.2.2 Monthly Maintenance .....	18
6.3 Ordering Replacement Parts.....	19
<b>7. Troubleshooting .....</b>	<b>20</b>
<b>8. Stacker Body Components.....</b>	<b>21</b>
<b>9. Control Pod - Date Code 4/2019 &amp; Prior .....</b>	<b>22</b>
<b>10. Control Pod - Date Code After 4/2019.....</b>	<b>23</b>
<b>11. Steering Assembly .....</b>	<b>24</b>
<b>12. Drive Wheel Assembly .....</b>	<b>25</b>



13.	Carriage Assembly .....	26
14.	Mast Assembly .....	27
15.	Hydraulic System .....	28
16.	Hydraulic Power Unit .....	29
17.	Hydraulic Schematic .....	30
18.	Control Panel .....	31
19.	Electrical Schematic.....	32
20.	Battery Connection .....	33
21.	Daily Operator Checklist.....	34
22.	Warranty & Contact Information .....	35



**This label (part # 10095524)  
is required by California law.  
For more information visit  
[www.P65Warnings.ca.gov](http://www.P65Warnings.ca.gov).**



1-800-295-5510  
[uline.com](http://uline.com)

## 1. Introduction

This manual attempts to provide all of the information necessary for the safe and proper installation, operation and maintenance of Presto Lifts Inc. battery operated, Power Stak. It is important that all personnel involved with the installation, maintenance or operator of the stacker read this manual. Additional manuals are available upon request or at [www.PrestoLifts.com](http://www.PrestoLifts.com). Each Presto stacker is equipped with nameplate, serial number and model identifications. Please refer to these numbers when ordering parts or requesting further information. The Presto stackers are designed for lifting, lowering and positioning a wide variety of loads. WHERE UNIQUE SITUATIONS ARISE, WHICH ARE NOT COVERED IN THIS MANUAL, CALL PRESTO LIFTS FOR FURTHER INSTRUCTIONS.

The battery operated stackers are designed for in-plant/non-hazardous locations only. They can be used in a 8' or larger aisle. These units are not for personnel lifting.

### **NOTICE**

**This machine is designed for powered travel and should not be manually moved by applying force to the Control Pod Handles. The Control Pod and steering arm should only be moved side to side when the machine is under power. The Control Pod and steering arm should be lowered to the drive position and power, Forward or Reverse, is engaged by moving the thumb wheel in the direction of desired travel then the steering arm can be moved side to side for directional steering. Pushing or pulling on the Control Pod Handles when the unit is not powered can lead to damage and/or breakage**

### 1.1 Responsibilities of Owner and Users

**Basic Principles** - Owners/users shall apply sound principles of safety, training, inspection, maintenance, and expected operating environment. It shall be the responsibility of the owner/user to advise the manufacturer where deflection may be critical to the application.

**Manuals** - Owners/users shall keep and maintain a copy of the operating and maintenance manual(s) and ensure its availability to operating and maintenance personnel.

**Inspection and Maintenance** - It shall be the responsibility of the users to inspect and maintain the machine as required to ensure proper operation. The frequency of inspection and maintenance shall be based upon the manufacturer's recommendations and be compatible with operating conditions and the severity of the operating environment. Machinery that is not in proper operating condition shall be immediately removed from service until repaired. Maintenance and repairs shall be made by a qualified person and the repairs shall be in conformance with the manufacturer's recommendations.

**Maintenance Safety Precautions** - Before adjustments and repairs are started on the machine, the following precautions shall be taken as applicable:

1. Remove the load from the load enclosure.
2. Lower platform to the full down position.
3. Relieve system pressure from all circuits before loosening or removing any components.
4. All controls in the "off" position and all operating features secured from inadvertent motion by brakes, blocks, or other means.
5. Disconnect power and follow established owner/user lockout/tag out policies.
6. Follow precautions and directions as specified by the manufacturer.

**ULINE**

1-800-295-5510

[uline.com](http://uline.com)

**Replacement Parts** - When parts or components are replaced, they shall be replaced with parts or components approved by the original manufacturer.

**Maintenance Training** - The user shall ensure only qualified personnel inspect and maintain the machine in accordance with the manufacturers recommendations.

**Operator Training** - An owner/user, who directs or authorizes an individual to operate the machine shall ensure that the individual has been:

1. Trained in accordance with the manufacturer's operating manual.
2. Made aware of the responsibilities of operators as outlined in section 1.4 of this manual.
3. Retrained, if necessary, based on the owners/user's observation and evaluation of the operator.

**Modifications** and additions shall not be performed without the manufacturer's prior written approval. Where such authorization is granted, capacity, operation, and maintenance instruction plates, tags, or decals shall be changed accordingly.

## 1.2 Responsibilities of Operators

**Basic Principles** - Operators shall apply sound principles of safety and good judgment in the application and operation of the machine with consideration given to its intended use and expected operating environment. Since the operator is in direct control of the machine, conformance with good safety practices is the responsibility of the operator. The operator shall make decisions on the use and operation with due consideration for the fact that his or her own safety as well as the safety of other personnel on or near the machine is dependent on those decisions.

**General Training** - Only personnel who have received general instructions regarding the inspection, application and operation of machine, including recognition and avoidance of hazards associated with their operation, shall operate the machine. Such topics covered shall include, but not necessarily be limited to, the following issues and requirements:

1. A pre-start inspection
2. Responsibilities associated with problems or malfunctions affecting the operation of the machine.
3. Factors affecting stability
4. The purpose of placards and decals
5. Workplace inspection
6. Safety rules and regulations
7. Authorization to operate
8. Operator warnings and instructions
9. Actual operation of the machine. Under the direction of a qualified person, the trainee shall operate the machine for a sufficient period of time to demonstrate proficiency in actual operation of the machine.

**Pre-start Inspection** - Before use each day or at the beginning of each shift, the machine shall be given a visual inspection and functional test including but not limited to the following:

1. Operating and emergency controls
2. Safety devices
3. Hydraulic system leaks

**ULINE**

1-800-295-5510  
uline.com

4. Electrical cables and wiring harness
5. Loose or missing parts
6. Nameplates, precautionary and instructional markings and/or labeling
7. Guarding system
8. Items specified by the manufacturer

**Problem or Malfunctions** - Any problems or malfunctions that affect the safety of operations shall be repaired prior to the use of the machine.

**Before Operations** - The operator shall:

1. Read and understand the manufacturer's operating instruction(s) and user's safety rules or have them explained
2. Understand all labels, warnings, and instructions displayed on the machine or have them explained.

**Workplace Inspections** - Before the machine is used and during use, the operator shall check the area in which the machine is to be used for possible hazards such as, but not limited to:

1. Bumps, floor obstructions and uneven surfaces
2. Overhead obstructions and electrical hazards
3. Presence of unauthorized persons
4. Other possible unsafe conditions as noted in the operating manual.

**Operator Warnings and Instructions** - The operator shall ensure the operation of the machine is in compliance with the following:

1. **Guarding system** - Guarding shall be installed and positioned, and access gates or openings shall be secured per the manufacturer's instructions (If applicable).
2. **Distribution of load** - The load and its distribution on the platform shall be in accordance with the manufacturer's rated capacity for that specific configuration.
3. **Maintaining overhead clearance** - The operator shall ensure that adequate clearance is maintained from overhead obstructions and energized electrical conductors and parts.
4. **Point of Operation** - The operator shall not place any part of their body under the platform.
5. **Precaution for moving equipment** - When other moving equipment or vehicles are present, special precautions shall be taken to comply with the safety standards established for the workplace.
6. **Reporting problems or malfunctions** - The operator shall immediately report to a supervisor any problem(s) or malfunction(s) that become evident during operation. The operator shall ensure all problems and malfunctions that affect the safety of operations are repaired prior to continued use.
7. **Capacity limitation** - Rated capacity shall not be exceeded when loads are transferred to the load enclosure.
8. **Work area** - The operator shall ensure the area surrounding the machine is clear of personnel and equipment before lowering the load enclosure.
9. **Securing the machine** - The operator shall comply with the means and procedures provided to protect against use by an unauthorized person(s).

**ULINE**

1-800-295-5510

uline.com

10. **Altering safety devices** - Safety devices shall not be altered or disabled.
11. **Modifications** or alterations of the machine or the fabrication and attaching of frameworks or the mounting of attachments to the machine or the guarding system shall only be accomplished with prior written permission of the manufacturer.
12. **Assistance to the operator** - If an operator encounters any suspected malfunction or any hazard or potentially unsafe condition relating to capacity, intended use or safe operation the operator shall cease operation of the machine and request further instruction from the owner/user.
13. **Problems or malfunctions** - Any problem(s) or malfunction(s) that affect the safety of operations shall be repaired prior to the use of the machine.

## 2. Safety

All personnel installing, operating, and maintaining this machine shall read and understand this manual. For questions or concerns contact the manufacturer.

All operators of this machine must be trained, by their employer, in accordance with OSHA standard 1910.178 29QFR-7-1-06 before being permitted to operate this machine.

### 2.1 Safety Alert Symbols

A symbol that indicates a hazard. It is composed of an equilateral triangle surrounding an exclamation mark. The safety alert symbol is only used on hazard alerting signs. It is not used on safety notice and safety instructions signs.

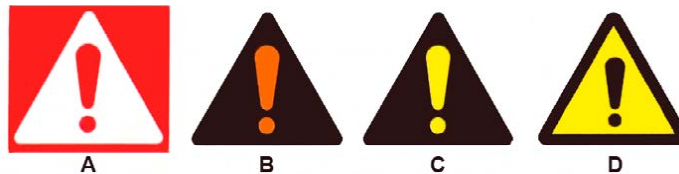

**A** – For use with **DANGER** signal word; (safety white triangle, safety red exclamation mark, safety red background)

**B** – For use with **WARNING** signal word; (safety black triangle, safety orange exclamation mark)

**C** – For use with **CAUTION** signal word; (safety black triangle, safety yellow exclamation mark)

**D** – For use with **DANGER, WARNING, or CAUTION** signal words; (**D** is a safety yellow triangle with a safety black border and safety black exclamation mark;

### 2.2 Signal Words



**DANGER** Indicates a hazardous situation that, if not avoided, will result in death or serious injury.



**WARNING** Indicates a hazardous situation that, if not avoided, could result in death or serious injury.



**CAUTION** Indicates a hazardous situation that, if not avoided, could result in minor or moderate injury.



**NOTICE** Indicates information considered important, but not hazard-related (e.g., messages relating to property damage).

**ULINE**

1-800-295-5510

uline.com

**DO NOT OPERATE THESE LIFTS WITHOUT CAREFULLY READING THIS MANUAL.** In order to provide for the safe operation of these stackers, Presto Lifts Inc. has identified certain hazards that may occur during the maintenance and use of these lifts. For safety reasons these units are designed to be serviced or repaired in the fully lowered position. If performed properly, this will greatly reduce the possibility of injury.

**When servicing the unit:**

1. Key should be in "OFF" position.
2. E-stop should be depressed.
3. Disconnect the batteries at the terminals.



**Do not perform any repair work on lifts if there is a load on the forks or platform.**

**Do not perform any repair work if the forks or platform is in the raised position.**

**All personnel must stand clear of the lift while in motion.**

**Do not put hands or feet under the forks or platform.**

**Do not stand underneath the forks or platform.**

**Do not stand in front of the stacker while in motion.**

**Do not stand, sit or climb on the lift.**

**Do not use the lift on soft, uneven or unstable surfaces.**

**Do not exceed the load center or capacity.**

**ULINE**

1-800-295-5510

uline.com





To avoid death or serious injury:

- Always be alert to the area around you and watch where you are walking. Be careful that you don't get pinned or crushed between the stacker and a fixed object such as a wall or post.
- Watch your hands and feet. A foot or hand caught between the stacker and a fixed object will be crushed or even cut off.
- If traveling forks first, keep both hands on the control handle and be careful when changing direction of travel. Keep your feet clear of the stacker.
- Keep the stacker under control at all times. Operate at a speed that allows you to stop safely. Be even more careful on slippery or uneven surfaces. Do not run over objects on the floor.
- Perform all stacker movements smoothly and at a speed that will give you time to react if an emergency occurs.
- Tip-overs and falls are very serious accidents; you can be crushed or even killed. To prevent injury, know where you are at all times and follow the rules of safe stacker operation.
- Be careful when working around docks, dock boards and trailers. Stay away from the edge of docks and ramps. Check to make sure the wheels of truck or trailers are chocked.
- Travel with the load or forks close to the ground. Watch for overhead obstructions. Perform all stacker movements smoothly and at a speed that will give you time to react in an emergency. DO NOT travel with forks or platform in an elevated position.
- Keep your hands and feet away from all moving parts such as masts, chains, forks or wheels.
- Never stand on or under the forks, or allow anyone else to stand on or under them. Never ride on the stacker or allow anyone else to ride.
- Before you leave your stacker, be sure to lower the forks to the floor. Shut the stacker off with the key.
- DO NOT use this stacker until you have been trained and authorized to do so.
- DO NOT operate until you have read all warnings and instructions.
- DO NOT exceed load center or load weight capacities (check capacity plate).
- DO NOT operate until you have checked the conditions of the stacker: lift systems, forks, chains, and cables.
- DO NOT use if any part is damaged, worn or not working properly.
- DO NOT use on ramps or inclines. Only smooth level surfaces.
- DO NOT use for lifting or carrying people.
- DO NOT handle unbalanced, unstable, loosely stacked, or loads that exceed the rated capacity.
- DO NOT operate when parts of anyone's body may be close to mast structure or any moving parts.
- DO NOT drop loads on platform or forks.
- DO NOT alter or modify this stacker in any way.



1-800-295-5510  
uline.com

### 3. Labeling

This machine has labeling to indicate potential hazards this machine may pose when operating and/or maintaining the machine. All labels are legible. If any label is missing, damaged, or otherwise illegible contact the manufacturer for replacement labels.

#### 3.1 Label Placement Diagram

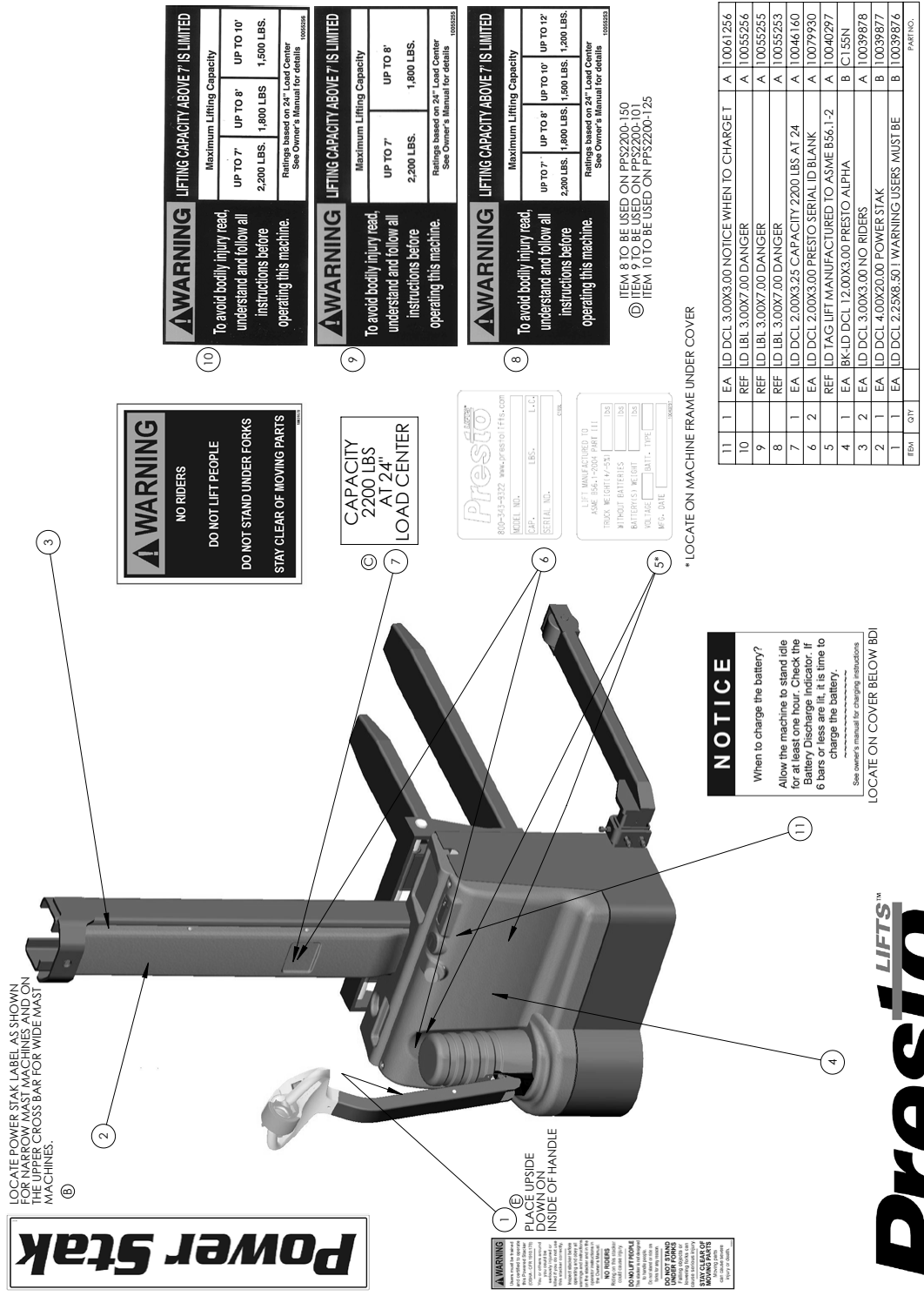

**WARNING** LIFTING CAPACITY ABOVE 7' IS LIMITED

To avoid bodily injury read, understand and follow all instructions before operating this machine.

Maximum Lifting Capacity	
UP TO 7'	UP TO 10'
2,200 LBS. 1,800 LBS.	1,500 LBS.

Rating based on 24" Load Center  
See Owner's Manual for details

**WARNING** LIFTING CAPACITY ABOVE 7' IS LIMITED

To avoid bodily injury read, understand and follow all instructions before operating this machine.

Maximum Lifting Capacity	
UP TO 7'	UP TO 8'
2,200 LBS.	1,800 LBS.

Rating based on 24" Load Center  
See Owner's Manual for details

**WARNING** LIFTING CAPACITY ABOVE 7' IS LIMITED

To avoid bodily injury read, understand and follow all instructions before operating this machine.

Maximum Lifting Capacity	
UP TO 7'	UP TO 10'
UP TO 8'	UP TO 12'
2,200 LBS. 1,800 LBS. 1,200 LBS.	1,200 LBS.

Rating based on 30" Load Center  
See Owner's Manual for details

- ITEM 8 TO BE USED ON PPS2200-150
- ITEM 9 TO BE USED ON PPS2200-101
- ITEM 10 TO BE USED ON PPS2200-125

\* LOCATE ON MACHINE FRAME UNDER COVER

ITEM	QTY	DESCRIPTION	PART NO.
11	1	EA. LD DCL 3.00X3.00 NOTICE WHEN TO CHARGE I	A 10061256
10		REF. LD LBL 3.00X7.00 DANGER	A 10055256
9		REF. LD LBL 3.00X7.00 DANGER	A 10055255
8		REF. LD LBL 3.00X7.00 DANGER	A 10055253
7	1	EA. LD DCL 2.00X3.25 CAPACITY 2200 LBS AT 24	A 10046160
6	2	EA. LD DCL 2.00X3.00 PRESTO SERIAL ID BLANK	A 10079930
5		REF. LD TAG LIFT MANUFACTURED TO ASME B56.1-2	A 10040297
4	1	EA. BK-LD DCL 12.00X3.00 PRESTO ALPHA	B C1 55N
3	2	EA. LD DCL 3.00X3.00 NO RIDERS	A 10039878
2	1	EA. LD DCL 4.00X20.00 POWERSTAK	B 10039877
1	1	EA. LD DCL 2.25X8.50! WARNING-USERS MUST BE	B 10039876

**NOTICE**

When to charge the battery?  
Allow the machine to stand idle for at least one hour. Check the Battery Discharge Indicator. If 6 bars or less are lit, it is time to charge the battery.

See owner's manual for charging instructions

LOCATE ON COVER BELOW BDI

**Presto**  
LIFTS™

**ULINE**

1-800-295-5510  
uline.com

## 4. Setup

### 4.1 Critical Procedure for Proper Wheel Traction

Proper Drive Wheel traction is obtained for the PowerStak Straddle unit using this Procedure. All PowerStak Models are designed and intended to operate on an unfinished concrete floor surface. If any PowerStak is operated on smooth or polished concrete, sealed concrete, epoxy sealed floor, linoleum or other smooth surfaces Drive Wheel traction performance may be affected; If traction issues are encountered Rubber Drive Wheels are available through special order. Please contact Customer Service at Presto Lifts 1-800-343-9322. When any PowerStak is operated on a wet, oily, powdery, sandy or non-uniform liquid or granular surface Drive Wheel traction performance will be affected and loss of traction will occur.

#### **NOTICE**

**Straddle legs must be adjusted and secured in accordance with these procedures.**

#### Setup procedure for straddle legs:

1. PowerStak unit located on flat, clean uniform surface, unloaded, forks raised a minimum of 1" off the floor.
2. Determine the desired/required straddle width dimension (2 inches greater than pallet width, 1" on each side of the pallet or load, up to a maximum of 50 inches inside width)
3. Be sure to fully loosen all bolts before moving stabilizing legs. A 14mm allen wrench is required for the bolts. Adjust one stabilizer leg at a time – using a pry bar, pinch bar, rubber mallet etc. move the straddle leg out from the base tube to the desired position. Do not move too far, see picture below, if the ¼" wide painted White Line is visible the leg is pulled out too far; Maximum movement 5 ½" for each leg for 2200 pound units.
4. Adjust second Straddle Leg – using a pry bar, pinch bar, rubber mallet etc. move the straddle leg out from inside the base tube to the desired straddle width position.

#### **NOTICE**

**Straddle Legs must be symmetrically adjusted, both legs adjusted to the same extended dimension.**

#### Set up procedure for PowerStak straddle legs with five bolts:

1. Back off all bolts.
2. Tighten Bolt 1 to 85 foot pounds.
3. Tighten Bolts two (2) to 85 foot pounds.
4. Tighten Bolt 3 to 85 foot pounds.
5. Tighten Bolt 4 to 25 foot pounds - NOT 85 foot pounds!
6. Securely tighten all lock nuts.

#### **NOTICE**

**When adjusted correctly, white line cannot be seen.**

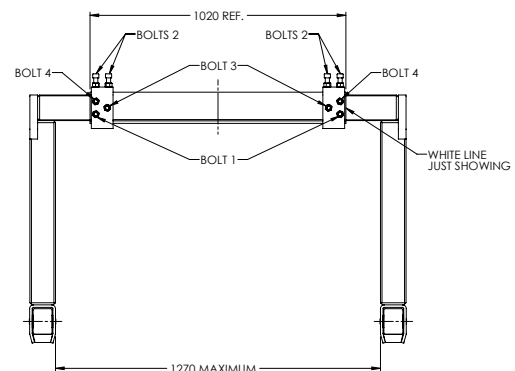

**ULINE**

1-800-295-5510  
uline.com

## 4.2 Inspection

Upon receipt of the stacker, inspect the equipment completely to determine if there is any shipping damage, and that the lift is complete. Presto tests and inspects every piece of equipment prior to shipment. If damage is apparent, a freight claim must be filed with the freight company. Do not use the stacker if there appears to be any damage. With the stacker in a lowered position, check the following:

- Check for signs of damage especially to the back cabinet that houses the battery, electrical/hydraulic power pack.
- Check all electrical and hydraulic connections for tightness.
- Remove back panel.
  1. Turn key switch to "OFF" position.
  2. Push in E-stop and unscrew the red knob.
  3. Lift off back panel. There is enough wire to the key switch to allow the panel to be set aside.
- Inspect for any bent or damaged parts.

## 4.3 Removing From Pallet

Each of the Presto stackers is shipped out on a pallet or skid. Prior to removing the unit from the pallet or skid, remove all tie down straps and packaging. Visually inspect the unit as closely as possible.

With an overhead hoist or forklift, carefully pick up the unit taking into consideration the center of gravity of the unit. If you choose to pick the unit with an overhead hoist, use a nylon sling and hoist with a minimum of 2,000-lb. capacity. The nylon sling will not do any damage to the steel construction of stacker. Pick the unit up. On conventional masts use the top cross-member of the lift. On narrow masts the cover must be removed to access lifting equipment. Be careful of the stacker swinging once fully lifted off the pallet or skid. Have all personnel completely cleared from the area.

Pick the unit up approximately six inches above the pallet or skid. Once raised, remove the pallet or skid from below the lift. Do not move the lift around in the air. Lower the stacker on the ground.

## 4.4 Preparation For Use

This stacker left our factory in new condition. It has been inspected and weight tested to assure all performance standards have been met.

Visually inspect the stacker for damage. Check for attachments and accessories that may have been ordered. If there is any damage or missing parts, report it to your carrier and your Presto dealer immediately.

Remove all metal/plastic bands, cardboard and other material used for shipping purposes.

Check to see if chains are in place, and that the lift system is in working order. Inspect for oil leaks. Connect battery cable. Check cables and wires on battery charger as well as battery.



## 4.5 Individual Fork Angle/Deflection Adjustment

The forks on this stacker are adjustable to allow compensating for fork deflection of various expected loads and to bring each fork in alignment with the other. Items 9 & 10 below are what will be adjusted to gain the desired fork angle.

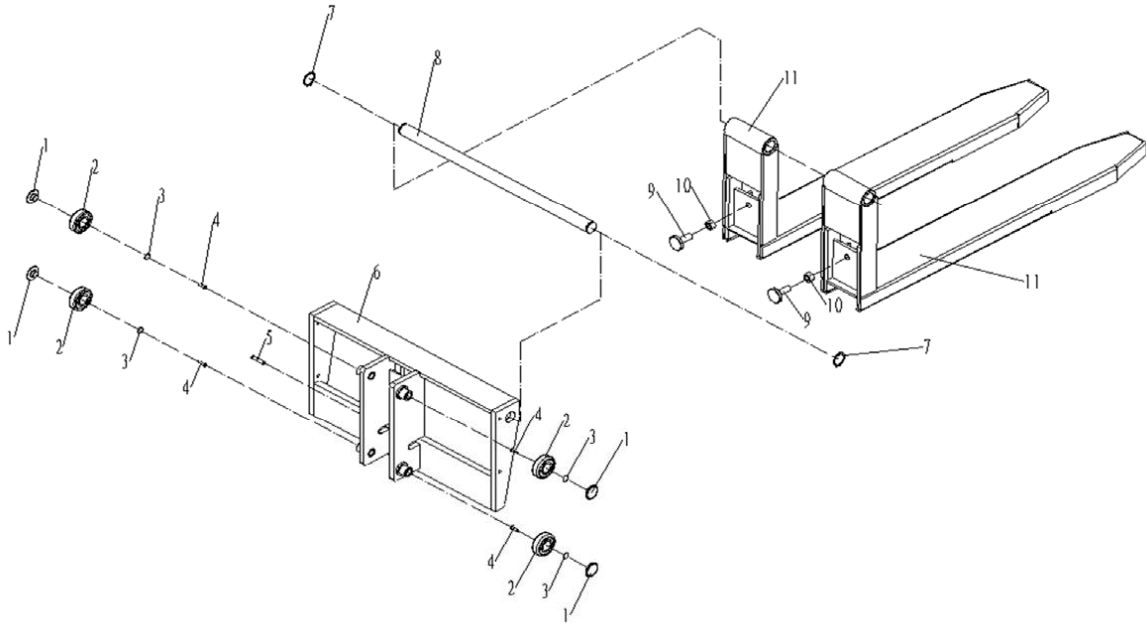

### **NOTICE**

Do not turn the adjustment knobs to the fully clockwise position as this may cause the bottom of the forks to rub against any irregularities on the floor under a fully loaded pallet or the load to shift forward potentially leading to unintentional releasing of product onto the floor.

1. Raise the forks to an ergonomic level to access the adjustment knobs.
2. Engage the E-STOP by pressing it in to avoid unexpected movement of the machine.
3. To access the adjustment knob and jam nut from behind the fork, lift up the fork.

### **NOTICE**

Individual fork weight approximately 50 lbs.



**ULINE**

1-800-295-5510  
uline.com

4. Turn the jam nut counterclockwise to loosen. If the nut is too tight, try turning the knob counterclockwise and that should also help to release the jam nut. If still not able to loosen, use a 15/16"/24mm wrench to turn. Once the jam nut is loosened, turn the adjustment knob clockwise or counterclockwise to the desired position.



5. Turn the adjustment knob clockwise to reduce the height of the end of the fork tip from the floor or counterclockwise to increase the height of the end of the fork from the floor.



6. Tighten jam nut by turning clockwise until hand tight. Then turn adjustment knob clockwise to essentially further tighten the jam nut.



7. Repeat steps 3 through 6 for the other fork.
8. Observe alignment of forks and repeat steps 3 through 7 to achieve desired results.



9. Once desired results have been achieved, tighten jam nuts with a 15/16"/24mm wrench.
10. Disengage E-STOP.
11. Lower the forks to the floor.

**ULINE**

1-800-295-5510  
uline.com



## 5. Operation

### 5.1 To Raise and Lower

There are two buttons located on both sides of the handle. The inside one is for lowering the forks. The outside one is for raising the forks. When operating, always make sure the load being lifted is within the loading capacity of your stacker and the load has been stacked safely on the pallet. Also, make sure that the length of the forks corresponds to the length of the pallet. In this way, the load rollers will place themselves in the opening at the end of the pallet, so that when you raise the forks, you will not break the bottom boards of the pallet. Always make sure that when entering the pallet that the forks are in the fully lowered position. Be careful when lifting pallets that are too short or too long for the stacker. It might destroy your pallet by breaking the bottom boards, and if the forks project through the end of the pallet, the tips of fork may go into the next pallet that is behind the pallet that you are lifting, which may bend the tips of forks and overload the capacity of the stacker.

### 5.2 Travel Function

To travel, rotate the butterfly controls throttle on the upper part of the handle. When rotating the butterfly control towards the forks, the stacker runs forwards in the forks first direction. When rotating the butterfly towards the operator, the stacker runs in the reverse direction. Always make sure the stacker clears any obstruction when traveling, and that your path of travel is clear of people. Never carry loads above the loading capacity of the stacker. It is suggested that when traveling without a load, the forks be in the lowered position. The speed of the stacker is increased by the degree of the rotation in either direction; it functions like a throttle. When you release your hand from the butterfly control, it automatically will resume to the neutral position and the speed of the stacker will slow down, and come to a stop.

### 5.3 Turtle Speed Travel

When the butterfly control is engaged forward (toward the forks) or reverse (toward the operator) if the operator simultaneously engages the turtle speed button the forward and/or reverse speed is limited to 50% of full speed or turtle speed. The operator can engage the butterfly forward with the right hand and engage the turtle speed button with the left hand. The operator can engage the butterfly forward with the left hand and engage the turtle speed button with the right hand. The reverse operation is also controlled with either hand. The turtle speed is maintained only when the turtle speed button is engaged. When the turtle speed button is not engaged the unit will operate at full speed. The turtle speed button is a maintained contact operation.

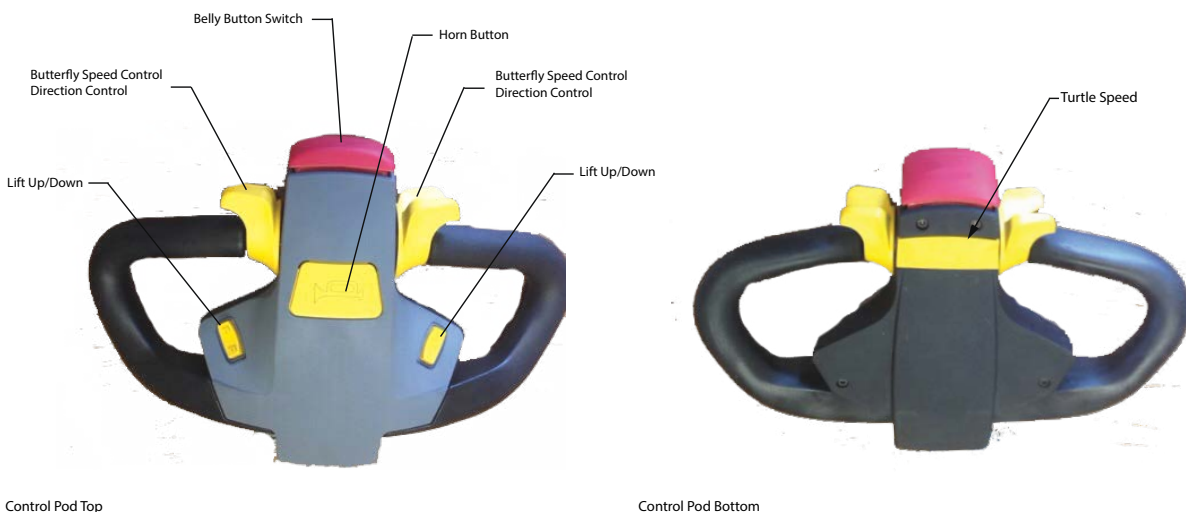

**ULINE**

1-800-295-5510

uline.com

## 5.4 Electric Brake

Your stacker is equipped with an electric magnetic brake. The brake is applied when the handle is in its vertical position between 10 – 15 degrees and lowered position between 80 – 90 degrees. The brake could be released when you pull down the handle at any point between 15 – 80 degrees. Always make sure the brake is released before operating the stacker. When the stacker is running, you could brake the stacker by raising the handle to its vertical position or lowering the handle to its lowest position. Or, to turn the butterfly controls in the opposite direction, the change in direction of the motor will slow down, stop, and reverse the direction of stacker. When parked, the handle will spring back to the full vertical position with the brake applied and the forks in lowered position.

## 5.5 Reversing Safety

At the end of the handle there is a large, red reversing bar (belly button switch) that is designed to protect the operator from injury. When the operator runs the stacker backwards, and the end of the handle comes in contact with the operator's body, the stacker will automatically reverse direction and travel away from the operator. When the reversing safety bar comes in contact with your body during operation, immediately release your hands from the butterfly control and put the handle up to its vertical position or down to its lowest position and the brake is on. The reversing safety bar will automatically resume to its original position after being activated.

## 5.6 Horn

As standard equipment, a horn that is located on the top of the handle.

## 5.7 Fork Angle Adjustment

To make any adjustment to the individual fork angles, see **Individual Fork Angle/Deflection Adjustment** section.

## 6. Maintenance & Repair



**DO NOT USE LIFT IF IT IS NOT OPERATING PROPERLY, OR APPEARS UNSAFE IN ANY WAY!**

**All maintenance to be performed with the forks fully lowered.**

**Turn off the key and disconnect the battery before performing any maintenance.**

### 6.1 Before Each Use

- Check for corroded and loose battery terminals. A white powder substance will be present if there is any existing corrosion.
- Visually inspect for any cracks or damage to the casing.
- Check for loose battery tie-downs.
- Inspect wire connections on the battery charger. Check power cord for nicks/damage.
- Check power charger for proper mounting.
- Inspect pump and cylinder for oil leaks.
- Check hydraulic oil level.
- Check hydraulic fittings and hoses.
- Check ram for nicks/damage.
- Check chain roller assembly connections.
- Check for any worn or damaged parts.

**ULINE**

1-800-295-5510

uline.com



## 6.2 Battery Maintenance



**Never alter the AC cord or plug provided. If it will not fit outlet, have proper outlet installed by a qualified electrician. Improper connection can result in a risk of an electric shock.**

### PREPARING TO CHARGE A BATTERY

Always turn off E-stop and key switch before working with the batteries. Be sure the area around the stacker and the battery is well ventilated while battery is being charged. The battery terminals, connections and wiring connections should be clean and free of corrosion. When cleaning any of these components wear a face shield or other suitable protective eye wear.

### BATTERY CHARGING

Charging must be performed with the charger that is provided with or pre-wired into the machine. During charging, the temperature in the battery must not exceed 120 F. Charging simultaneously with truck operation is not recommended. Plug the charger into a 115 volt outlet. Charge until the battery gauge indicator lights show fully charged (approximately 6-8 hours).

### WARNINGS AND BATTERY INFORMATION

Avoid use of open flame near batteries. At temperatures around freezing point, battery capacity is reduced by 30%. The battery terminals, connections and wiring should be clean and free of corrosion. When cleaning any of these components, wear a face shield or other suitable protective eye wear. Read, understand, and follow all battery and battery manufacturer's specific precautions while working with and/or charging batteries.

### BATTERY MAINTENANCE

To measure the voltage, use a digital voltmeter (DC) on the battery poles. The truck must not have been in use for the previous 30 minutes.

### BATTERY CHARGER OPERATION

Disconnect the charger from the 115 volt wall outlet once the indicators read fully charged.

Recommend charging the system before the BDI indicates empty in order to extend battery life.



#### LED Instruction:

- Red light on: Charge error (Voltage <11V)
- Red flashing light: Battery reversed polarity
- Yellow flashing light: No battery connected
- Yellow light on: Normal charging
- Green flashing light: 80% charged
- Green light on: Fully charged
- Two leftmost LEDs blinking indicate EMPTY

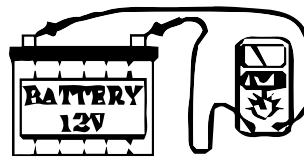

Voltage	State
12.7V	Fully Charged
12.2V	1/2 Charged
12.0V	1/4 Charged
11.6V	Fully Discharged

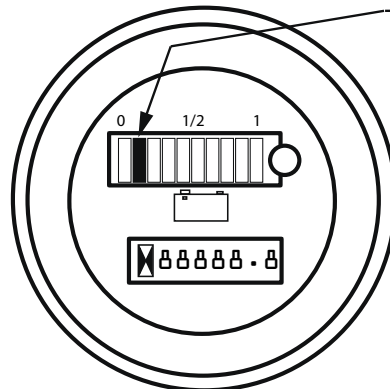

Here, second from left LED blinks indicating reserved power is above 70%. At this point we recommend charging the system



1-800-295-5510  
uline.com

## **6.3 Periodic Maintenance**

### **6.3.1. Weekly Maintenance**

- Inspect the machine for damage. Check for bent, dented, or broken parts.
- Check the lift system for binding or excessive movement in the forks. Check for quiet and smooth operation of the lift cylinder. Check all moving parts and linkages.
- Check the hydraulic system for leaks. Check hydraulic fluid level.
- Check wheels and castors for wear and/or damage. Ensure they turn smoothly.
- Inspect lift chains. Check to see they are in place and not loose.
- Inspect forks. Check for bending and/or cracks.
- Inspect the brake. Verify the brake works correctly.
- Inspect all electrical wiring for loose connections or damage.
- Verify all precautionary labeling is in place and legible.

### **6.3.2. Monthly Maintenance**

- Clean battery terminals and battery compartment.
- Clean and inspect the hydraulic cylinder for leaks or damage.
- Lubricate the chain with a rust inhibitive lubricant (light machine oil).
- Check chain tension. It should be even on both chains. The chain should be tight enough so that it does not come off the roller assembly.
- Inspect the frame assembly for damage or wear.
- Clean and lubricate all roller bearings, cam followers, and all moving parts.
- Clean and inspect all welds.
- Check wheels for wear or damage.
- Inspect the nameplates. Verify they are legible.
- Check battery, motor, controllers, limit switches, electrical conductors and connections.



#### 6.4 Ordering Replacement Parts

Presto has carefully chosen the components in your lift to be the best available for the purpose. Replacement parts should be identical to the original equipment. Presto will not be responsible for equipment failures resulting from the use of incorrect replacement parts or from unauthorized modifications of the machine.

Presto will gladly supply you with replacement parts for your Presto lift. With your order, please include the model number and the serial number of the lift. You can find these numbers on the name plate. When you are ordering parts for a cylinder, also include the cylinder number. This is stamped on the base of the cylinder housing.

To order replacement parts, please call the Parts Department. See Warranty & Contact Information section.

- Parts are shipped subject to the following terms:
- FOB factory
- Returns only with the approval of our parts department.
- Payment net 30 days (except parts covered by warranty).
- Freight collect (except parts covered by warranty).
- The warranty for repair parts is 30 days from date of shipment.

Parts replaced under warranty are on a “charge-credit” basis. We will invoice you when we ship the replacement part, then credit you when you return the worn or damaged part, and we verify that it is covered by our warranty. Labor is not covered under warranty for Parts orders.



## 7. Troubleshooting



Turn off key and disconnect the battery before performing any maintenance.

### Unit will not lift (motor does not run)

- Faulty wiring from fuse to lift switch in handle
- Faulty lift switch
- Faulty wiring from battery positive terminal to pump contactor to pump motor.
- Burned out brushes in pump motor
- Low hydraulic pressure caused by:
  - Pressure relief valve needs adjustment
  - Pump check valve stuck open
  - Faulty solenoid valve
- Faulty wiring from lift switch to solenoid
- Faulty lift contactor
- Defective control circuit fuse
- Chain or roller bound
- Check oil level

### Forks will not lower

- Look for binding in chains or rollers

### No electrical power

- Dead Batteries:
  - Keyswitch on "OFF" position
  - E-stop button depressed
  - Loose or dirty battery connections
  - Blown fuse(s)
- Faulty wiring from fuse to travel control switch
- Faulty control switch
- Faulty wiring from travel control switch direction contactor
- Faulty contactor

**ULINE**

1-800-295-5510  
uline.com



## 9. Control Pod - Date Code 4/2019 & Prior

For machines with date codes 4/2019 and prior stamped into the mast.

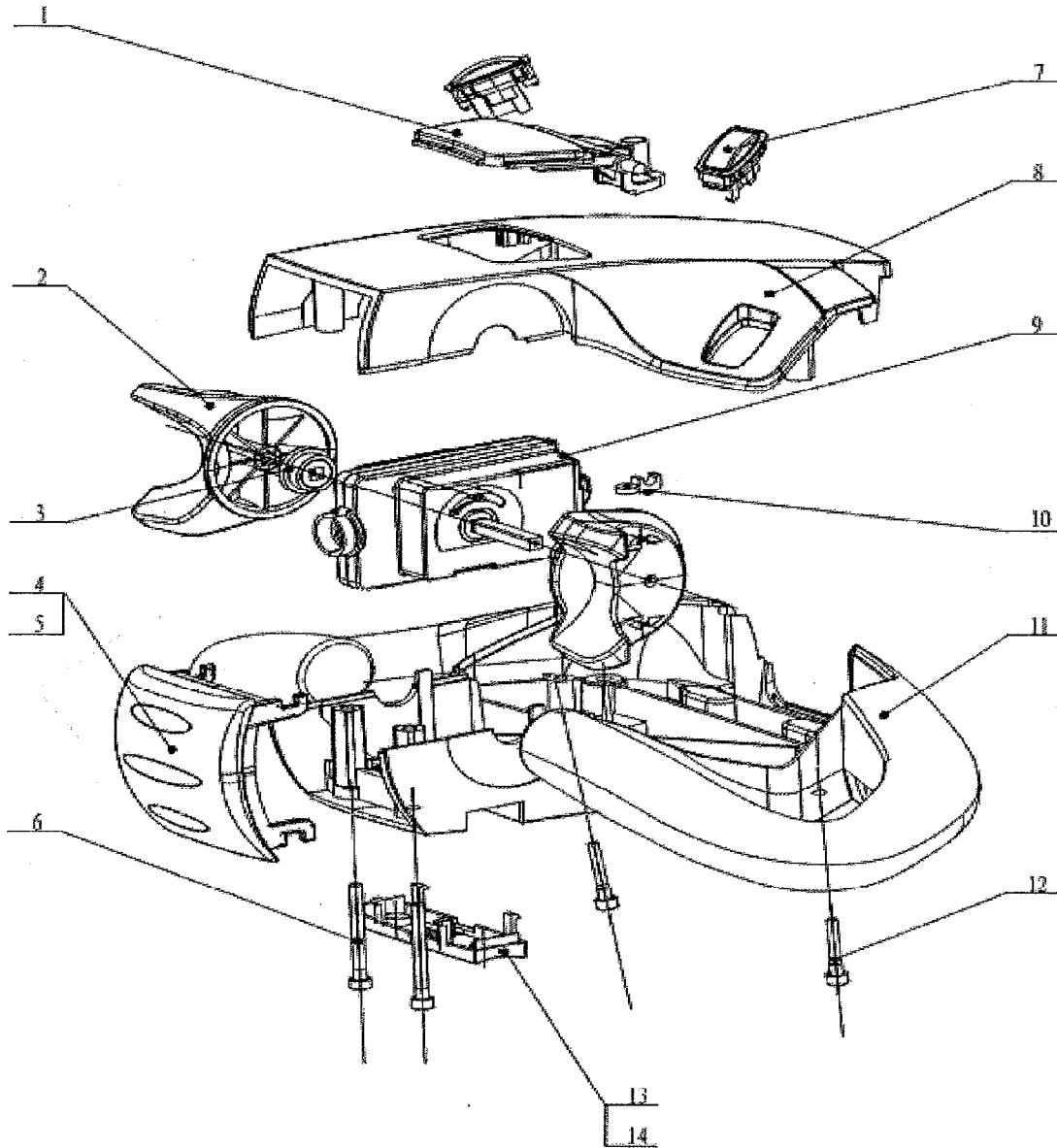

Item	Description	Qty
1	Horn Button	1
2	Knob	2
3	Bearing	2
4	Belly Switch	1
5	Spring	1
6	Hexagon Socket Screw	2
7	Lift Switch	2

Item	Description	Qty
8	Top Cover	1
9	Accelerator Assembly	1
10	Snap Ring	2
11	Base	1
12	Hexagon socket Screw	2
13	Button	1
14	Spring	2

**ULINE**

1-800-295-5510

uline.com

## 10. Control Pod - Date Code After 4/2019

For machines with date codes after 4/2019 stamped into the mast.

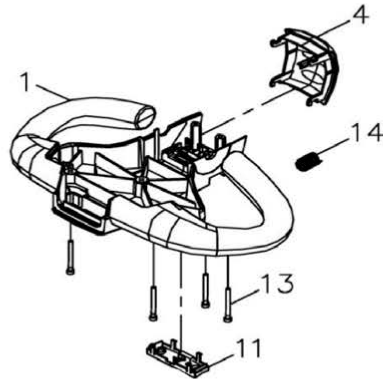
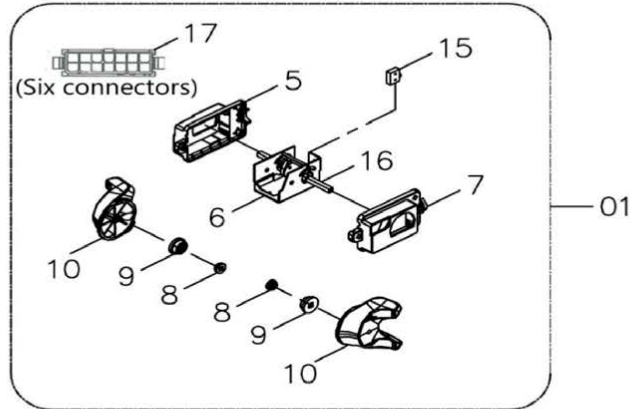
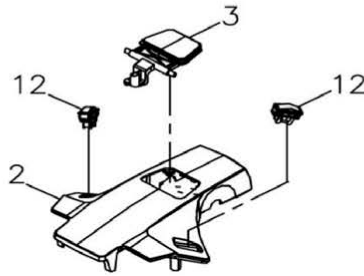

Item	Description	Qty
0	Control Pod	1
1	Handle Assembly	1
1	Handle Grip	1
2	Upper Cover	2
3	Horn Assembly	1
4	Emergency Button	1
5	Switch Cover	1
6	Accelerator Switch	1
7	Switch Cover	1
8	Inner Bearing	2

Item	Description	Qty
9	Outer Bearing	2
10	Knob	2
11	Switch Assembly	1
12	Lift/Lowering Switches	2
13	Bolt	4
14	Spring	1
15	Micro Switch	1
16	Shaft	1
17	Socket	6

**ULINE**

1-800-295-5510  
uline.com

# 11. Steering Assembly

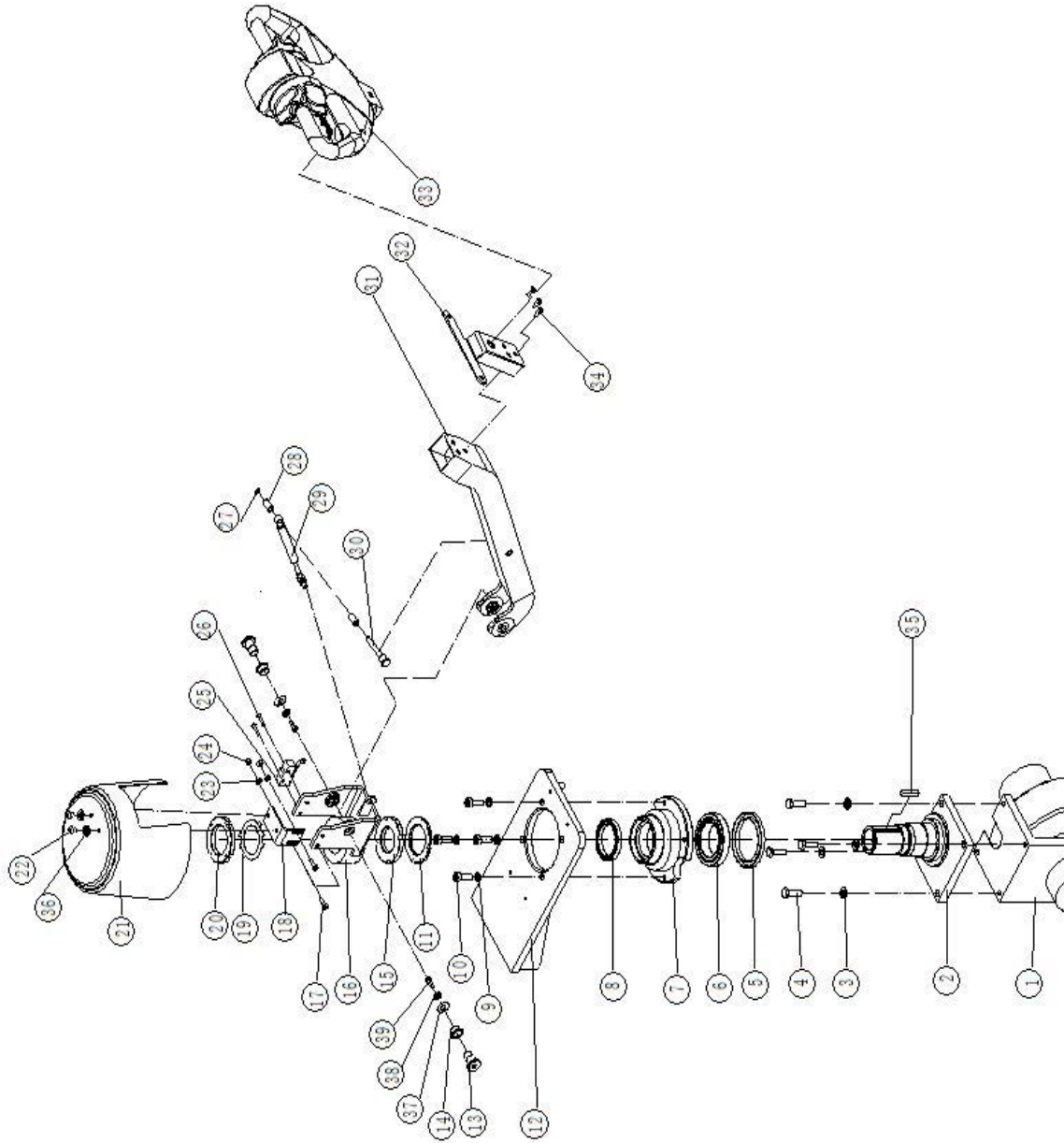

Item	Description	Qty
1	Drive Wheel Assy	1
2	Spindle Assy	1
3	Spring Washer	4
4	Bolt	4
5	Seal	4
6	Bearing	1
7	Spindle Seat	1
8	Bearing	1
9	Bolt	4
10	Spring Washer	4
11	Washer	1
12	Fixing Board, Drive Wheel	1
13	Bolt	2
14	Collar Spindle	2
15	Lock Nut	1
16	Seat Connection	1
17	Bolt	2
18	Anchor Spindle Cover	1
19	Lock Washer	1
20	Nut	1
21	Cover Spindle	1
22	Screw	2
23	Spring Washer	2
24	Nut	2
25	Switch	1
26	Bolt	2
27	Snap Ring, Axial	1
28	Spindle Collar	2
29	Air Spring	1
30	Fixing Shaft	1
31	Steering Arm	1
32	Anchor Handle	1
33	Control Pod	1
34	Bolt	3
35	Flat Key	1
36	Washer	2
37	Washer	2
38	Spring Washer	2
39	Bolt	2



1-800-295-5510

uline.com



## 12. Drive Wheel Assembly

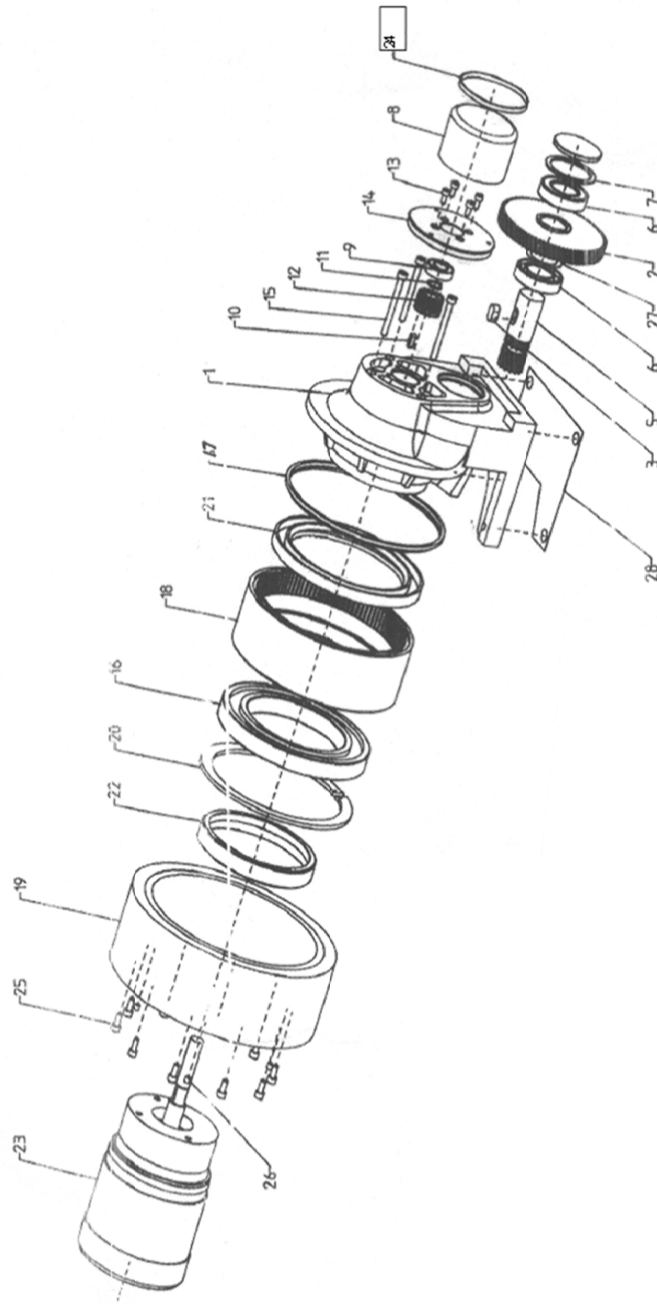

Item	Description	Qty
1	Casing	1
2	Gear, Big	1
3	Key	1
4	Cover, Dust	1
5	Shaft, Gear	1
6	Bearing	2
7	Baffle Ring	1
8	Electromagnetic Braker	1
9	Bearing	1
10	Key	2
11	Baffle Ring	1
12	Gear, Small	1
13	Screw	4
14	Flange	1
15	Screw	3
16	Bearing	1
17	Seal	1
18	Ring Gear	1
19	Wheel	1
19A	Drive Wheel (Black Rubber)	1
19B	Drive Wheel (Grey Rubber)	1
20	Baffle Ring	1
21	Seal	1
22	Ring, Back Up	1
23	Motor, Traction	1
24	Ring, Dust	1
25	Screw	10
26	Screw	3
27	Spacer	1
28	Panel	1

**ULINE**

1-800-295-5510

uline.com

### 13. Carriage Assembly

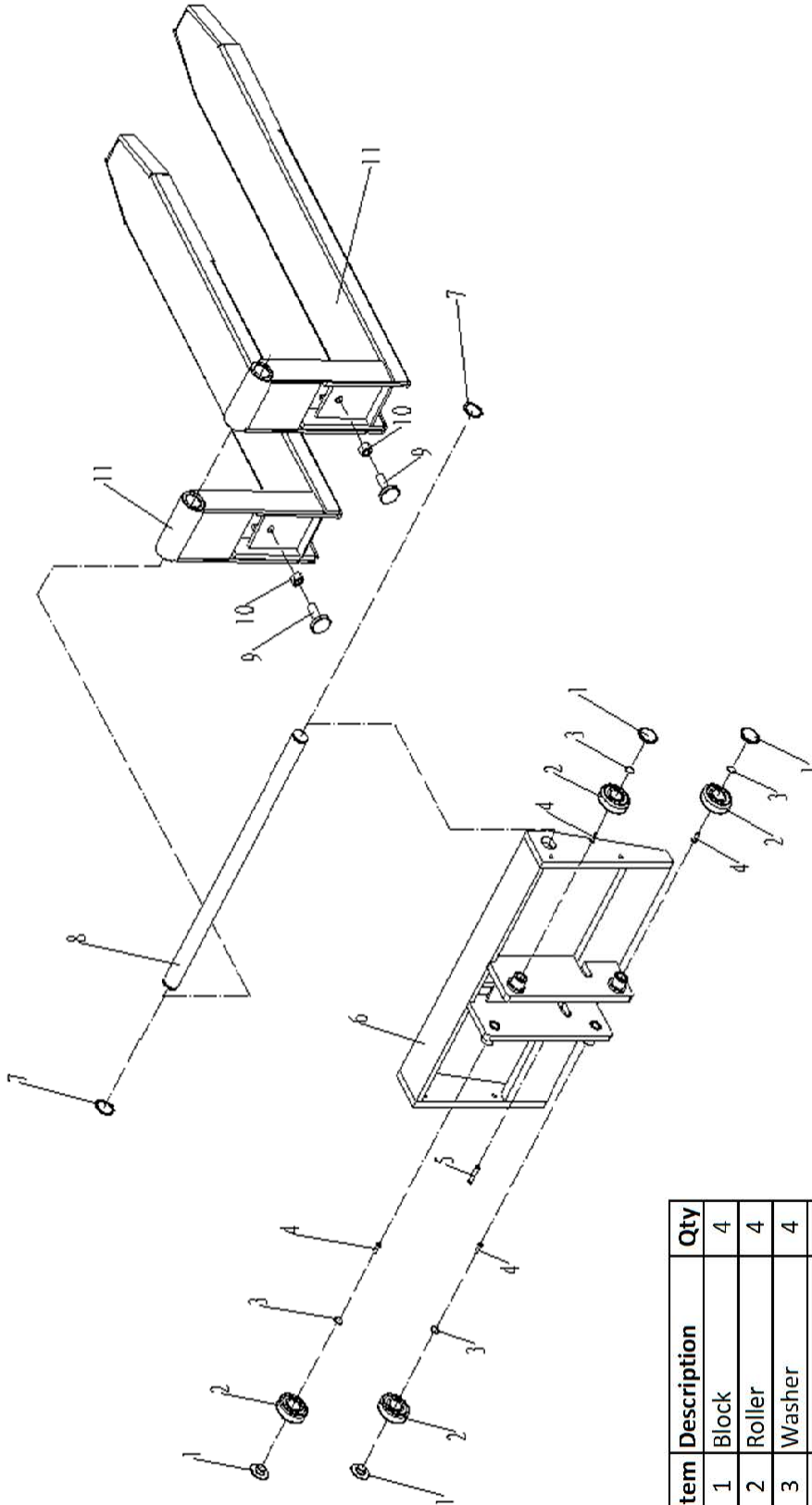

Item	Description	Qty
1	Block	4
2	Roller	4
3	Washer	4
4	Bolt	4
5	Fixed Pin, Chain	1
6	Carriage Assy	1
7	Snap Ring	2
8	Feed Shaft	1
9	Bolt	2
10	Nut	2
11	Fork Assy	2

**ULINE**

1-800-295-5510  
uline.com

# 14. Mast Assembly

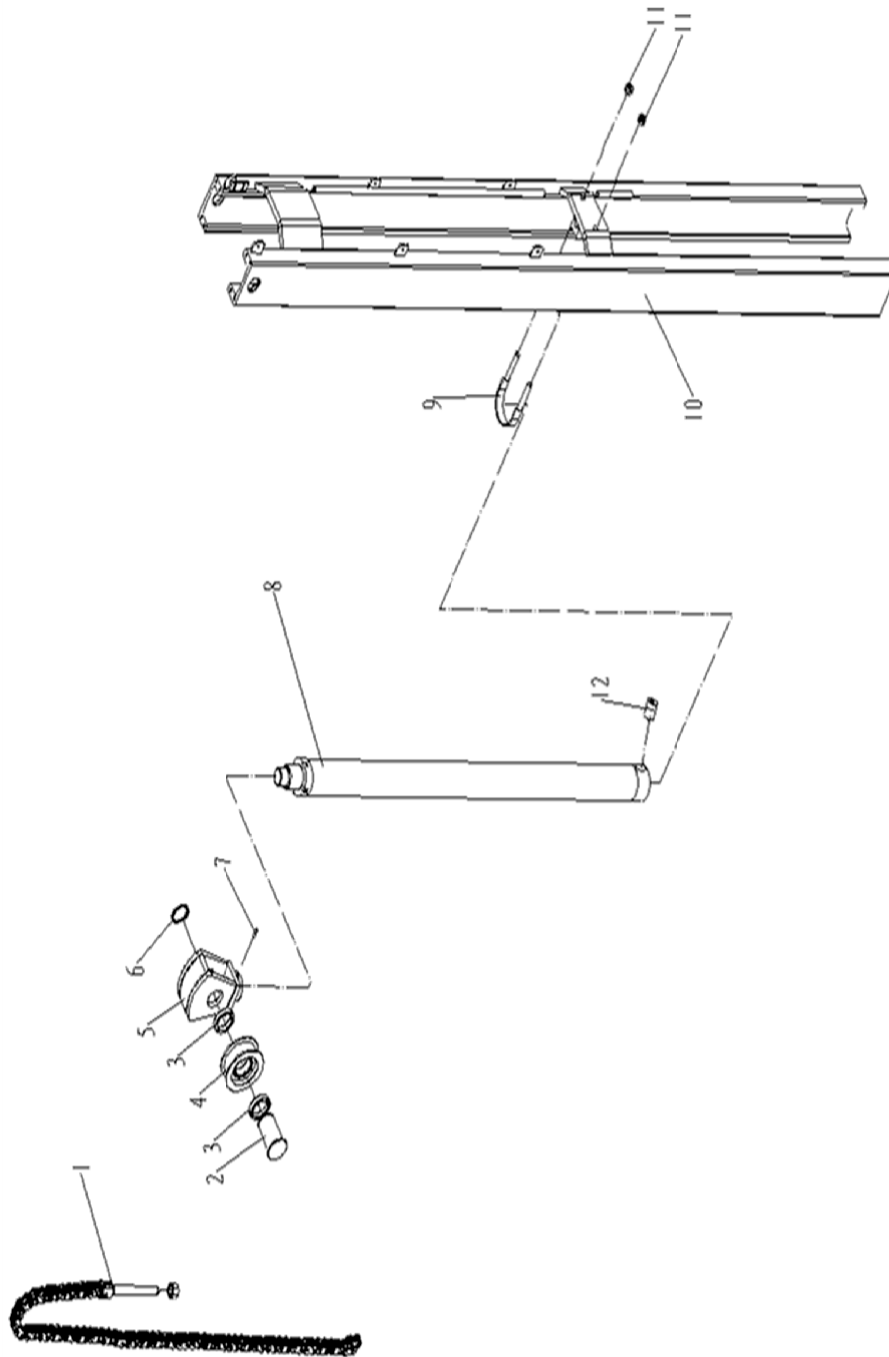

Item	Description	Qty
1	Chain Assy	1
2	Pivot Pin	1
3	Spacer	2
4	Wheel, Chain	1
5	Seat, Chain Wheel	1
6	Snap Ring	1
7	Bolt	1
8	Lift Cylinder	1
9	U Bolt	1
10	Mast Assembly	1
11	Lock Nut	2
12	Control Valve	1

**ULINE**

1-800-295-5510  
uline.com

## 15. Hydraulic System

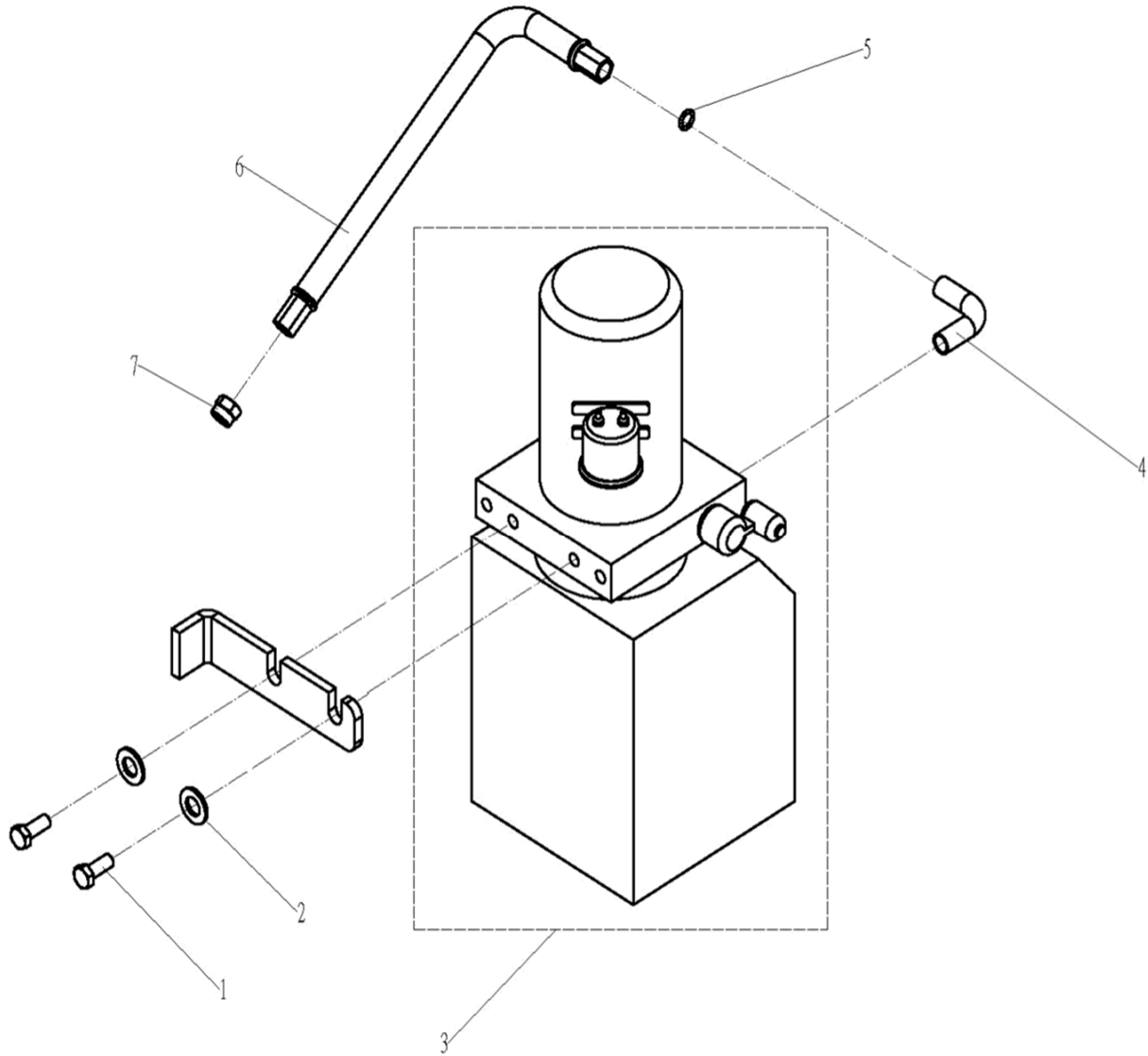

Item	Description	Qty
1	Screw	2
2	Washer	2
3	Hydraulic Assy	1
4	L-Adaptor	1
5	O-Ring	1
6	Oil Hose	1
7	Adaptor	1

**ULINE**

1-800-295-5510  
uline.com

# 16. Hydraulic Power Unit

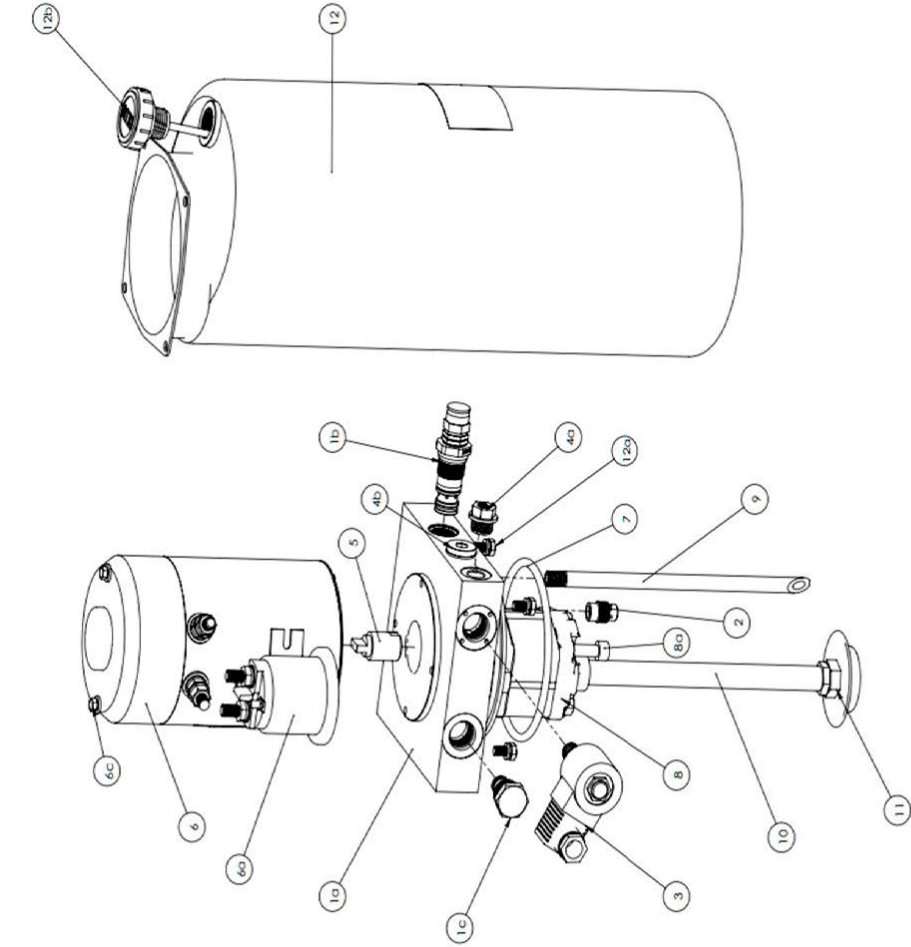

Item	Description	Qty
8	Gear Pump	1
8C	Bolt, With Spring Washer	2
9	Oil Hose, Return	1
10	Oil Hose, Suction	1
11	Filter	1
12	Oil Tank, Plastic	1
12A	Bolt, With Spring Washer	1
12B	Cover, Oil Tank	1

Item	Description	Qty
1A	Valve Block	1
1B	Relief Valve	1
1C	Unilateral Valve	1
2	Throttle Valve	1
3	DC Hydraulic Valve Assembly (Down Valve)	1
4A	Screw Plug (Metal)	1
4B	Screw Plug (Plastic)	1
5	Coupling	1
6	HPU DC Motor	1
7	O-Ring	1



1-800-295-5510  
uline.com

# 17. Hydraulic Schematic

Schematic Diagram of Hydraulic System

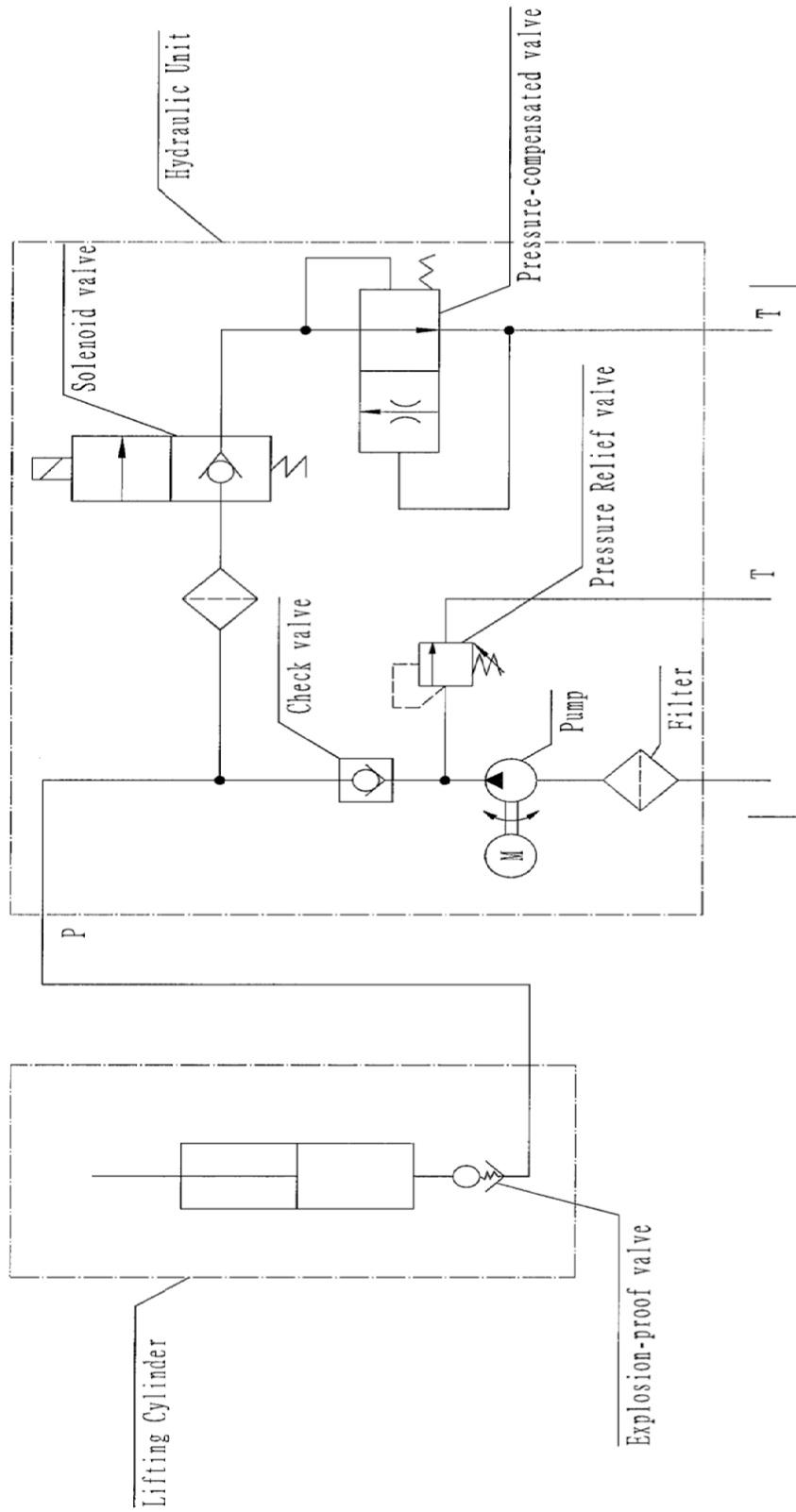

## 18. Control Panel

### CONTROL PANEL

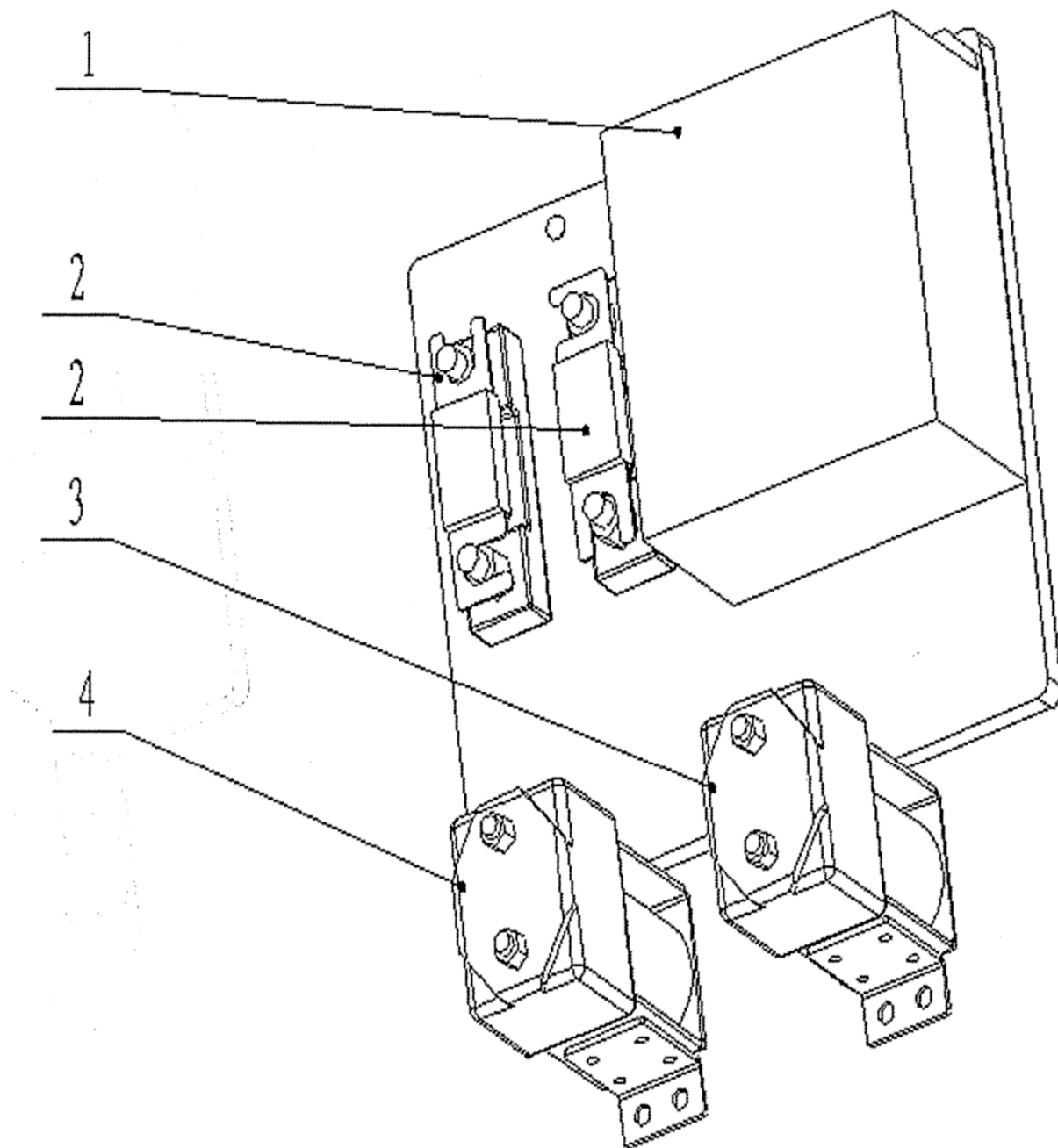

Item	Description	Qty
1	Controller	1
2	Fuse	1
3	Travel Contactor	1
4	Lifting Contactor	1

**ULINE**

1-800-295-5510  
uline.com

# 19. Electrical Schematic

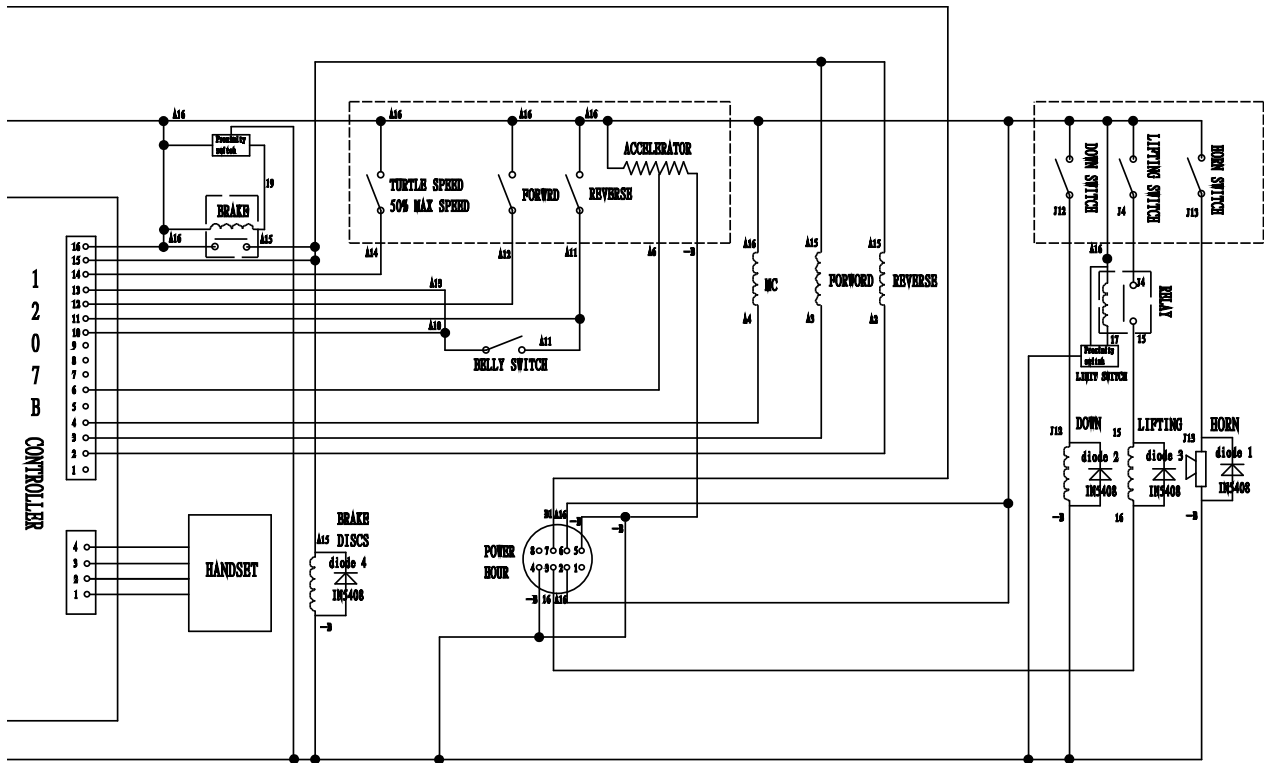
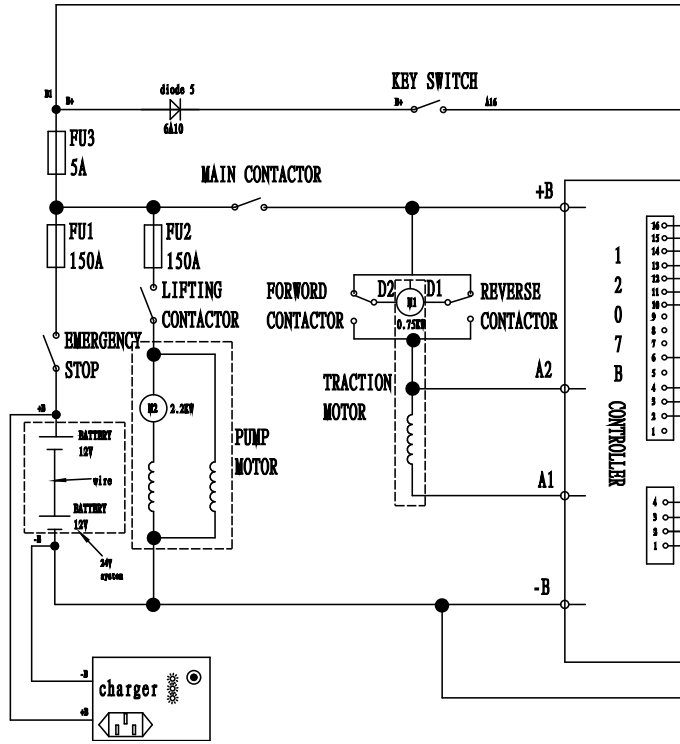

**ULINE**

1-800-295-5510  
uline.com



## 20. Battery Connection

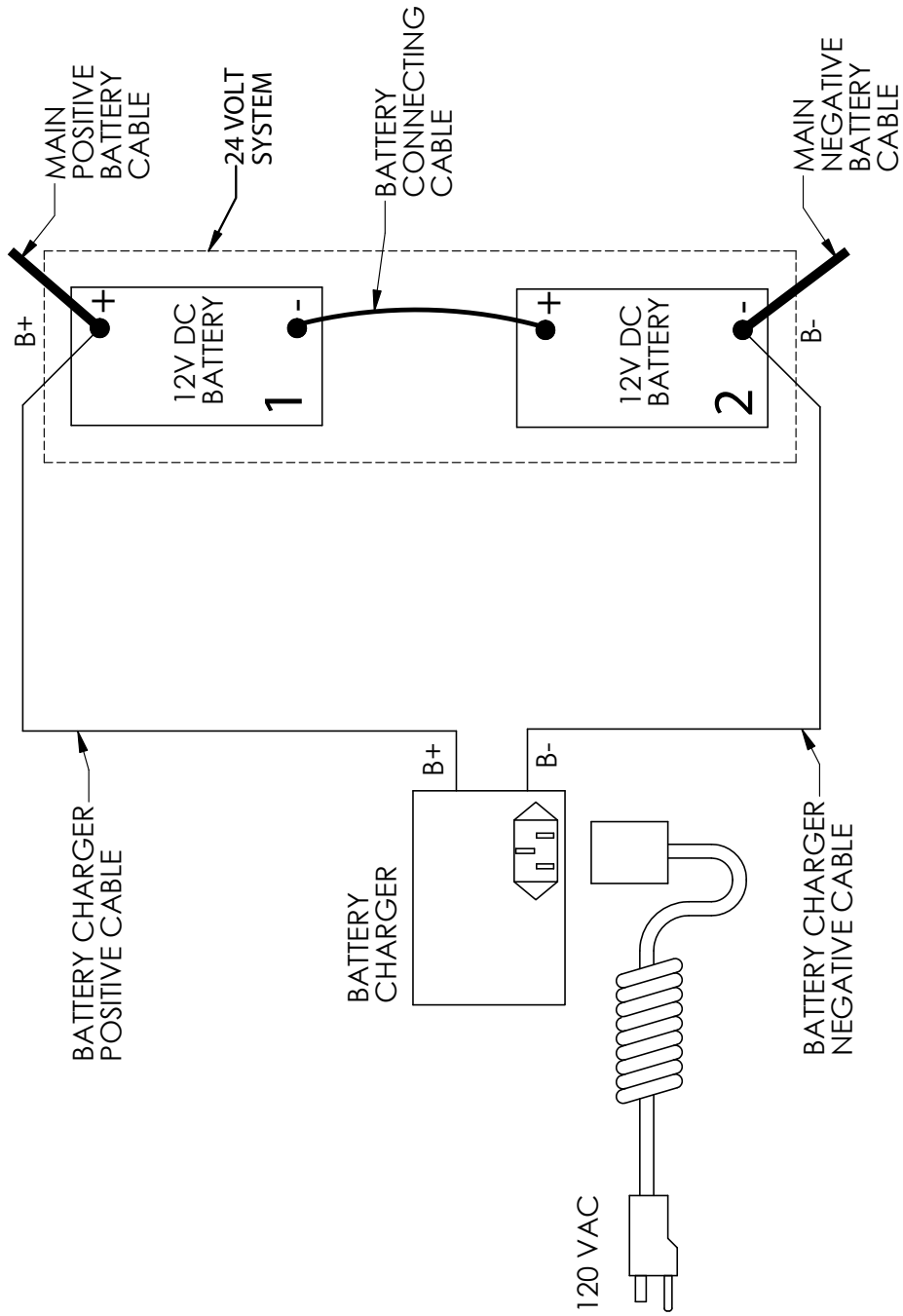

**ULINE**

1-800-295-5510  
uline.com

## 21. Daily Operator Checklist

### CHARGE CONDITION/BATTERY CHECK LIST

1. Check Battery Discharge Indicator (Fuel Gage and Hour Meter) – Be sure unit is showing proper Charge Level before operating unit
2. Check to be sure Charging Cord is Unplugged and properly stowed before operating unit
3. Inspect Battery Wire Connections – All connections should be tight with No Corrosion (white powder) showing at the Battery Terminals
4. Inspect Battery Case – There should be no cracks or visible damage to the Battery Case

### WALK AROUND INSPECTION

5. Check general condition of Stacker (loose or broken parts, oil, dangling wires, dents, cracked covers etc.)
6. Check metal frame, mast, carriage and front load supports for cracked welds, worn or flat rollers, loose or disconnected chains, loose pins, missing snap rings, and loose or missing hardware – bolts, nuts washers etc.
7. Check for evidence of hydraulic leaks
8. Make sure all precautionary labeling is in place and legible

### FUNCTIONAL INSPECTION

9. Check Drive – Forward and Reverse Function
10. Check Lift – Up and Down Function
11. Check Function for Belly Button Reverse
12. Check Horn Function
13. Check Brake Function

DO NOT USE OR OPERATE STACKER IF ANY FUNCTION IS NOT  
OPERATING PROPERLY OR IF STACKER APPEARS UNSAFE  
IN ANY WAY!

REPORT CONCERNS TO SUPERVISOR IMMEDIATELY!

OPERATOR ID \_\_\_\_\_

DATE \_\_\_\_\_

**ULINE**

1-800-295-5510  
uline.com

## 22. Warranty & Contact Information

Presto Lifts warrants this product to be free from defects in material or workmanship for the duration of the warranty period. Warranty periods vary and begin on the date of shipment. For specific warranty information, contact Presto Lifts with the machine's serial number.

Any claim for breach of this warranty must be received in writing by Presto Lifts within the warranty period. Warranties shall not cover failure or defective operation, caused by misuse, misapplication, negligence or accident, exceeding recommended capacities, or any alteration or repair of the item purchased which has not been authorized by Presto Lifts. Except as set forth herein, Presto Lifts makes no other warranties, express or implied, including THE WARRANTIES OF MERCHANTABILITY AND OF FITNESS FOR A PARTICULAR PURPOSE, all of which ARE HEREBY EXCLUDED.

Presto Lifts meets the labeling requirements of California's Proposition 65. Presto Lifts makes no warranty or representation with respect to the compliance of any product with other State or local safety or product standard codes and any failure to comply with such codes shall not be considered a defect of material or workmanship under this warranty. Presto Lifts shall not be liable for any direct or consequential damages arising out of such non-compliance.

Presto Lifts' obligations under any warranty or for any other damages which may arise under any sale, agreement, or contract, are limited to the replacement or repair of defective components at its factory or another location at Presto Lifts' discretion. This is buyer's sole remedy under any such warranty, sale, agreement, or contract. Presto Lifts will not be liable for consequential, incidental, exemplary, or punitive damages of any kind resulting from a breach of any warranty that it has provided or for breach of any term of any sale, agreement, or contract. Any warranty may be altered only in writing by Presto Lifts.

All commodities, software, or technology purchased from Presto Lifts are subject to the export and re-export control laws and regulations of the United States, including but not limited to the Export Administration Regulations ("EAR") and Department of the Treasury Office of Foreign Asset Controls ("OFAC") Regulations. Presto Lifts expects all distributors and customers to comply with these laws and regulations. Without limiting the foregoing, the distributor/customer cannot, without proper authorization from the applicable United States Government Agency, export, re-export, or transfer any commodity, software, or technology purchased from Presto Lifts, either directly or indirectly, to any entity, country, or national of any country in breach of such laws and regulations. Furthermore, Presto Lifts expects that the distributor/customer shall indemnify and hold harmless Presto Lifts from and against any claim, proceeding, action, fine, loss, cost and damages arising out of or relating to any noncompliance with export control regulations by distributor/customer, and distributor/customer are expected to compensate Presto Lifts for all losses and expenses resulting thereof, unless such noncompliance was clearly not caused by fault of the distributor/customer.

Presto Lifts Inc., 2 Hampshire Street, Suite 102, Foxborough, MA 02035  
800.343.9322 | Fax: 888.788.6496  
service@prestolifts.com  
www.PrestoLifts.com



To view a copy of the Terms and Conditions of Sale, go to: <https://PrestoLifts.com>  
(Find in About Us pull down menu)

**ULINE**

1-800-295-5510  
uline.com