

# ULINE H-4565 MONARCH 1136 TWO LINE LABEL GUN

1-800-295-5510  
uline.com

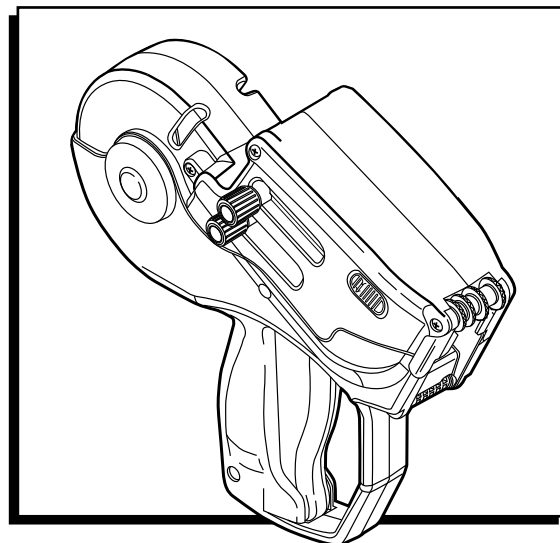

## INSTRUCTIONS

### CHANGING THE INK ROLLER

1. Pull the latches back and swing the cover open completely. You should hear a click.

 **NOTE:** Do not force the cover past the click position.

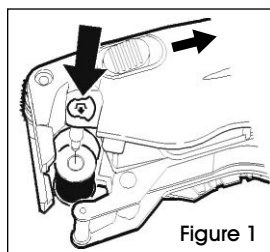

Figure 1

2. Hold the labeler sideways over a trash can while pushing the button to release the ink roller. (See Figure 1)

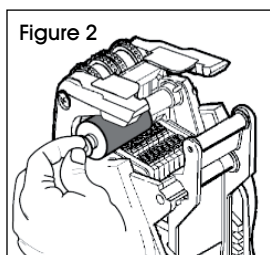

Figure 2

3. Hold the new ink roller by the stem. (See Figure 2) Slide it onto the post, snapping it into place. (See Figure 2)
4. Close the cover completely.

### SETTING PRINT CHARACTERS

1. For the first line, use the character key on the top of the gun to find the alpha/numeric character conversion.

 **NOTE:** See character key on page 3.

2. Pull/push the knob until the indicators are on the desired band. (See Figure 3)
3. Turn the knob until the desired character appears between the indicators. To print a blank, select the blank space for that band. (See Figure 3)

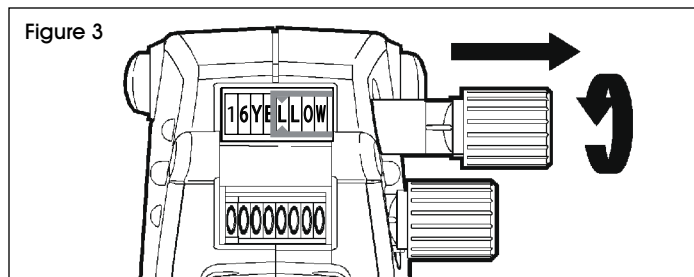

Figure 3

4. Repeat steps 2-3 for each band.
5. Fully push in the knob when you are done.
6. Repeat steps 2-5 for second line.

### LOADING LABELS

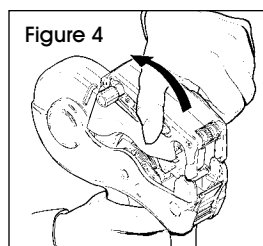



Figure 4

1. Pull the latches back and swing the cover open completely. You should hear a click. (See Figure 4)

 **NOTE:** Do not force the cover past the click position.

2. Before loading a new roll of labels, tear off and discard the first 10 inches of label and liner.
3. Then, to prevent jamming, peel the first 12 labels from liner and discard.

# INSTRUCTIONS CONTINUED

## LOADING LABELS CONTINUED

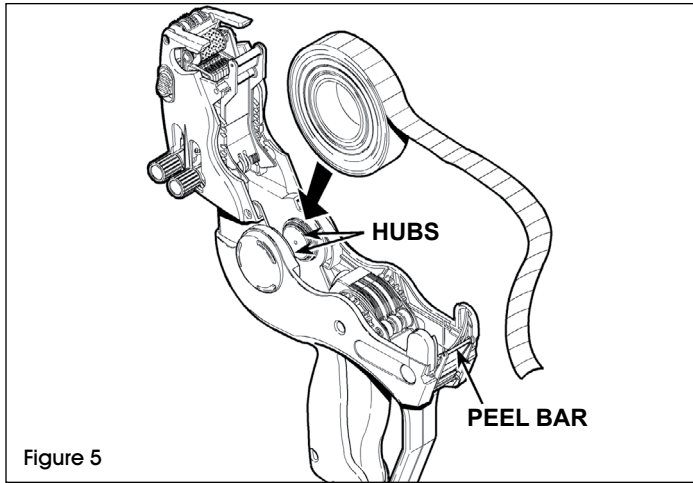

4. Place the label roll between the hubs and click into place. (See Figure 5)

 **NOTE:** Do not thread label strip through any rollers.

5. Drape the label strip across the labeler and center it over the peel bar. The label strip should hang out 5-6 inches past the peel bar.
6. Close the cover.
7. Squeeze and hold the trigger while feeding the label strip under the roller and into the large slot above the arrow until it stops/hits the back. (See Figure 6)
8. Hold the strip in place and squeeze the trigger eight times or until the label strip feeds through the rear exit.
9. Remove any loose labels.

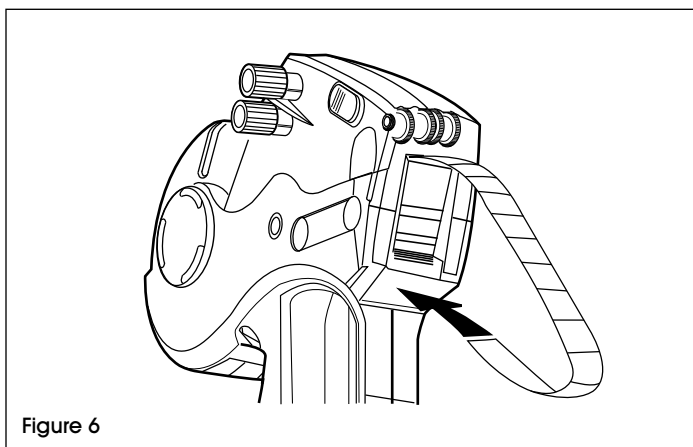

## CLEARING LABEL JAMS, CLEANING AND LUBRICATION

1. Open the cover and remove the label roll.
2. Remove any loose labels from the inside of the labeler. (See Figure 7)

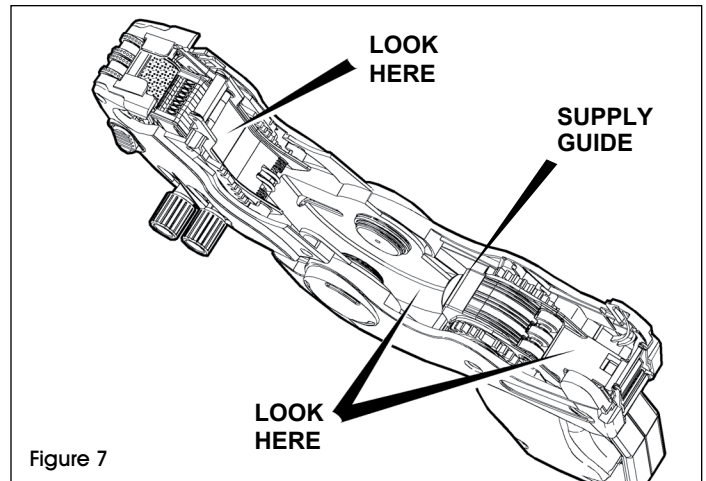

3. Pull up on the supply guide to expose the backing paper path and remove loose labels. (See Figure 8)
4. Snap the supply guide back into place.

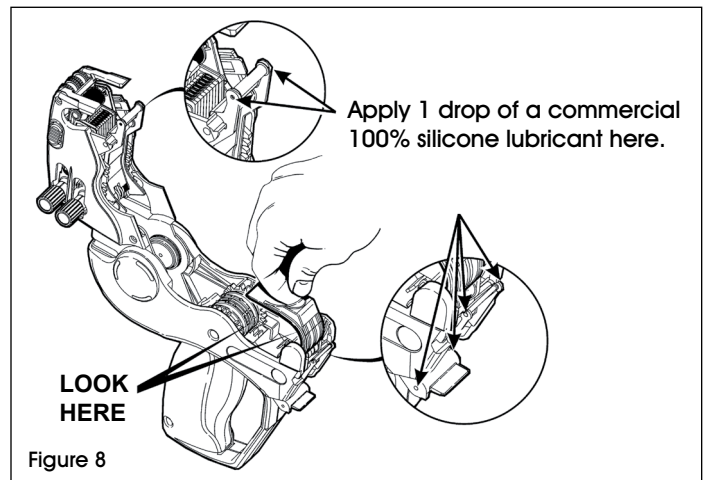

5. Use a commercial adhesive solvent to clean adhesive buildup.
6. Remove the ink roller to expose the print bands and brush them off with a toothbrush.
7. Reload, then close the cover.

# CHARACTER KEY

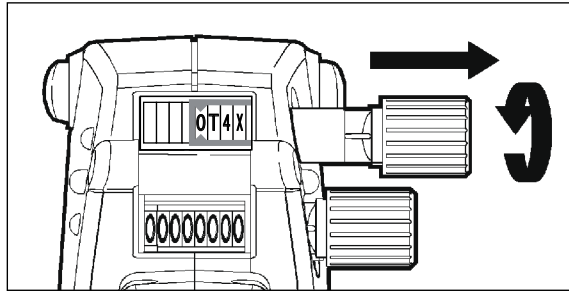

**1ST LINE WHEEL:** Opposite of wheel prints. (Example: If you want the label to read "SALE" choose "0T4X".) See conversion charts below.

## Regular Font (5 MM) 1st Line

KNOB POSITION

1 2 3 4 5 6 7 8

A↔T	A↔T	A↔T	A↔T	A↔T	A↔T	A↔T	A↔T
B↔U	B↔U	B↔U	B↔U	B↔U	B↔U	B↔U	B↔U
C↔V	C↔V	C↔V	C↔V	C↔V	C↔V	C↔V	C↔V
D↔W	D↔W	D↔W	D↔W	D↔W	D↔W	D↔W	D↔W
E↔X	E↔X	E↔X	E↔X	E↔X	E↔X	E↔X	E↔X
F↔Y	F↔Y	F↔Y	F↔Y	F↔Y	F↔Y	F↔Y	F↔Y
G↔Z	G↔Z	G↔Z	G↔Z	G↔Z	G↔Z	G↔Z	G↔Z
H↔I	H↔I	H↔I	H↔I	H↔I	H↔I	H↔I	H↔I
J↔2	J↔2	J↔2	J↔2	J↔2	J↔2	J↔2	J↔2
K↔3	K↔3	K↔3	K↔3	K↔3	K↔3	K↔3	K↔3
L↔4	L↔4	L↔4	L↔4	L↔4	L↔4	L↔4	L↔4
M↔5	M↔5	M↔5	M↔5	M↔5	M↔5	M↔5	M↔5
N↔6	N↔6	N↔6	N↔6	N↔6	N↔6	N↔6	N↔6
P↔7	P↔7	P↔7	P↔7	P↔7	P↔7	P↔7	P↔7
Q↔8	Q↔8	Q↔8	Q↔8	Q↔8	Q↔8	Q↔8	Q↔8
R↔9	R↔9	R↔9	R↔9	R↔9	R↔9	R↔9	R↔9
S↔0	S↔0	S↔0	S↔0	S↔0	S↔0	S↔0	S↔0

READ/PRINT ↔ PRINT/READ  
READ/PRINT ↔ PRINT/READ  
READ/PRINT ↔ PRINT/READ  
READ/PRINT ↔ PRINT/READ  
READ/PRINT ↔ PRINT/READ  
READ/PRINT ↔ PRINT/READ  
READ/PRINT ↔ PRINT/READ  
READ/PRINT ↔ PRINT/READ  
READ/PRINT ↔ PRINT/READ  
READ/PRINT ↔ PRINT/READ  
READ/PRINT ↔ PRINT/READ  
READ/PRINT ↔ PRINT/READ  
READ/PRINT ↔ PRINT/READ  
READ/PRINT ↔ PRINT/READ  
READ/PRINT ↔ PRINT/READ

## Regular Font (5 MM) 2nd Line

KNOB POSITION

1 2 3 4 5 6 7 8

1	1	1	.	.	1	1	LB
2	2	2	1	1	2	2	EACH
3	3	3	2	2	3	3	FOOT
4	4	4	3	3	4	4	DOZ
5	5	5	4	4	5	5	YARD
6	6	6	5	5	6	6	PAIR
7	7	7	6	6	7	7	PKG
8	8	8	7	7	8	8	BOX
9	9	9	8	8	9	9	CASE
0	0	0	9	9	0	0	SET
NOW	FOR	FOR	/	/	EACH	OFF	
\$	/	/	-	-	+TX	+TX	
					↻	↻	+TX
							+DEP

**ULINE**

1-800-295-5510  
uline.com

**ULINE H-4565**  
**MONARCH 1136**  
**ETIQUETADORA**  
**ALFANUMÉRICA – DOS**  
**LÍNEAS**

800-295-5510  
uline.mx

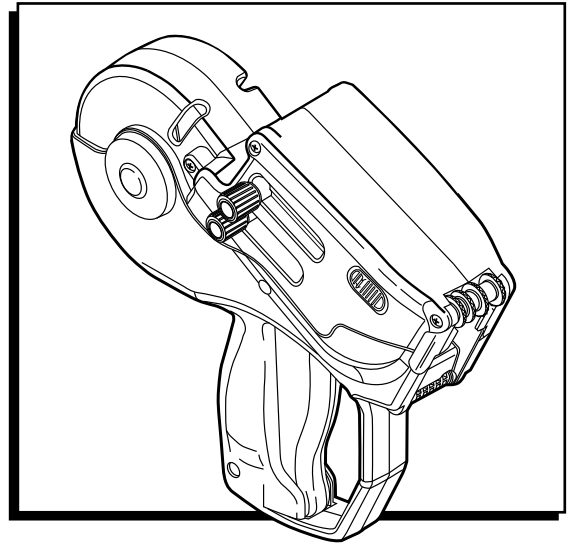

## INSTRUCCIONES

### CAMBIAR EL RODILLO DE TINTA

1. Jale los seguros hacia atrás y abra completamente la cubierta. Debería oír un clic.

 **NOTA:** No fuerce la cubierta más allá de la posición de clic.



Diagrama 1

2. Sujete la etiquetadora de lado sobre un bote de basura a la vez que aprieta el botón para liberar el rodillo de tinta. (Vea Diagrama 1)

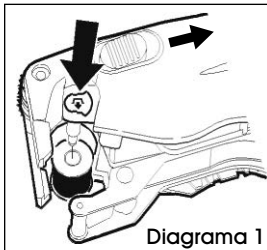

Diagrama 2

3. Sujete el nuevo rodillo de tinta por el tallo. (Vea Diagrama 2) Deslícelo por el poste, colocándolo en su lugar. (Vea Diagrama 2)
4. Cierre la cubierta completamente.

### CONFIGURAR LOS CARACTERES DE IMPRESIÓN

1. Para encontrar la conversión alfanumérica de los caracteres para la primera línea use la clave de caracteres en la parte superior de la etiquetadora.

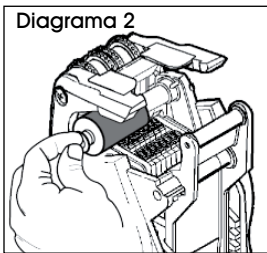
 **NOTA:** Vea la clave de caracteres en la página 6.

2. Jale/presione la perilla hasta que los indicadores se coloquen sobre la banda deseada. (Vea Diagrama 3)
3. Gire la perilla hasta que el carácter deseado aparezca entre los indicadores. Para imprimir un espacio en blanco, seleccione el espacio en blanco para esa banda. (Vea Diagrama 3)



Diagrama 3

4. Repita los pasos 2 a 3 para cada banda.
5. Presione la perilla del todo cuando haya terminado.
6. Repita los pasos 2 a 5 para la segunda línea.

### CARGAR ETIQUETAS ADHESIVAS



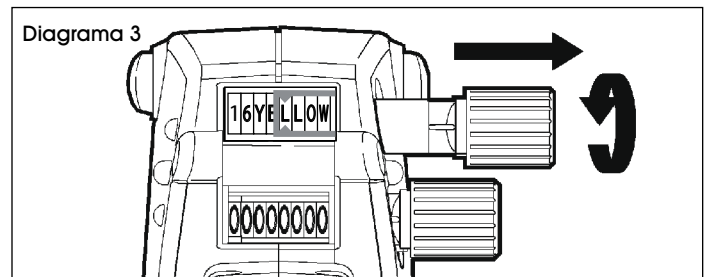

Diagrama 4

1. Jale los seguros hacia atrás y abra completamente la cubierta. Debería oír un clic. (Vea Diagrama 4)

 **NOTA:** No fuerce la cubierta más allá de la posición de clic.

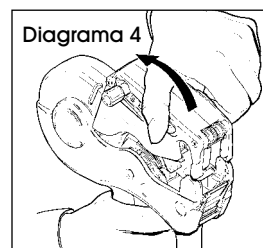
2. Antes de cargar un nuevo rollo de etiquetas adhesivas, rompa y deseche las primeras 25.4 cm (10 pulgadas) de etiqueta adhesiva y revestimiento.

## CONTINUACIÓN DE INSTRUCCIONES

### CONTINUACIÓN DE CARGAR ETIQUETAS ADHESIVAS

- Después, para evitar atascos, retire las primeras 12 etiquetas adhesivas del revestimiento y deséchelas.

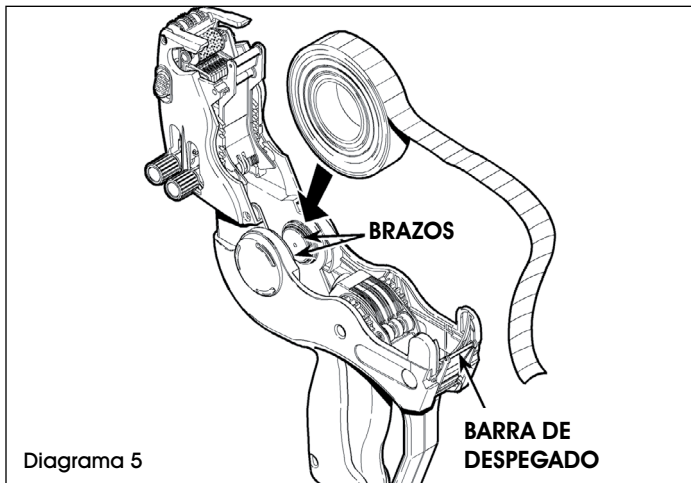

- Coloque el rollo de etiquetas adhesivas entre los brazos; estará en el lugar adecuado cuando oiga el clic. (Vea Diagrama 5)

 **NOTA:** No inserte la tira de etiquetas por ninguno de los rodillos.

- Pase la tira de etiquetas por encima de la etiquetadora y céntrala sobre la barra de despegado. La tira de etiquetas debe sobresalir 12.7 a 15.2 cm (5 a 6") por delante de la barra de despegado.
- Cierre la cubierta.
- Apriete y mantenga apretado el gatillo mientras se inserta la tira de etiquetas por debajo del rodillo y a través de la ranura grande por encima de la flecha hasta que se detenga/llegue al final. (Vea Diagrama 6)
- Sostenga la tira en su lugar y apriete el gatillo ocho veces o hasta que la tira de etiquetas asome por la salida posterior.
- Retire cualquier etiqueta adhesiva suelta.

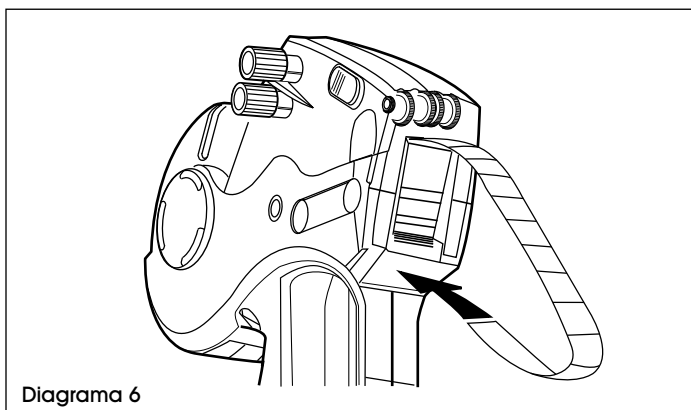

### ELIMINAR ATASCOS DE ETIQUETAS, LIMPIEZA Y LUBRICACIÓN

- Abra la cubierta y retire el rollo de etiquetas.
- Retire cualquier etiqueta adhesiva suelta de dentro de la etiquetadora. (Vea Diagrama 7)

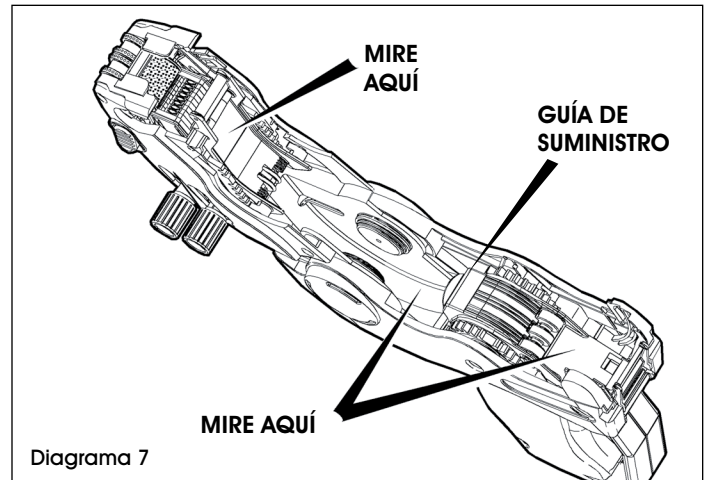

- Jale la guía de suministro para dejar a la vista el camino del papel del reverso y retire cualquier etiqueta adhesiva suelta. (Vea Diagrama 8)
- Coloque la guía de suministro de nuevo en su lugar ejerciendo una leve presión.

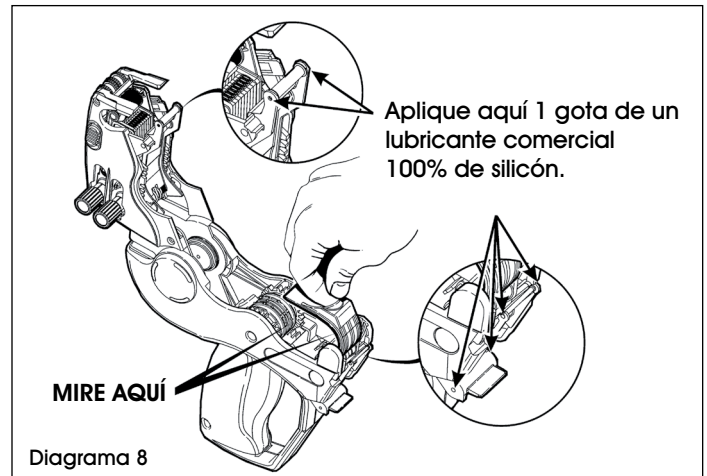

- Use un disolvente para adhesivo comercial para limpiar la acumulación de adhesivo.
- Quite el rodillo de tinta para dejar a la vista las bandas de impresión y cepílelas con un cepillo de dientes.
- Vuelva a cargar la herramienta y luego cierre la cubierta.

# CLAVE DE CARACTERES

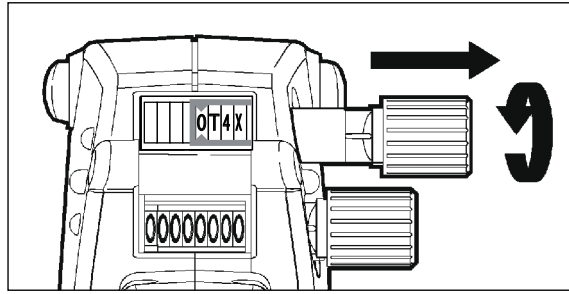

**Perilla de la 1.a Línea:** Opuesta a la perilla de impresiones. (Ejemplo: Si desea que la etiqueta diga "SALE" elija "OT4X"). Vea las tablas de conversión abajo.

## Letra Regular (5 MM) 1.a Línea

POSICIÓN DE LA PERILLA

1	2	3	4	5	6	7	8
A↔T	A↔T	A↔T	A↔T	A↔T	A↔T	A↔T	A↔T
B↔U	B↔U	B↔U	B↔U	B↔U	B↔U	B↔U	B↔U
C↔V	C↔V	C↔V	C↔V	C↔V	C↔V	C↔V	C↔V
D↔W	D↔W	D↔W	D↔W	D↔W	D↔W	D↔W	D↔W
E↔X	E↔X	E↔X	E↔X	E↔X	E↔X	E↔X	E↔X
F↔Y	F↔Y	F↔Y	F↔Y	F↔Y	F↔Y	F↔Y	F↔Y
G↔Z	G↔Z	G↔Z	G↔Z	G↔Z	G↔Z	G↔Z	G↔Z
H↔I	H↔I	H↔I	H↔I	H↔I	H↔I	H↔I	H↔I
J↔2	J↔2	J↔2	J↔2	J↔2	J↔2	J↔2	J↔2
K↔3	K↔3	K↔3	K↔3	K↔3	K↔3	K↔3	K↔3
L↔4	L↔4	L↔4	L↔4	L↔4	L↔4	L↔4	L↔4
M↔5	M↔5	M↔5	M↔5	M↔5	M↔5	M↔5	M↔5
N↔6	N↔6	N↔6	N↔6	N↔6	N↔6	N↔6	N↔6
P↔7	P↔7	P↔7	P↔7	P↔7	P↔7	P↔7	P↔7
Q↔8	Q↔8	Q↔8	Q↔8	Q↔8	Q↔8	Q↔8	Q↔8
R↔9	R↔9	R↔9	R↔9	R↔9	R↔9	R↔9	R↔9
S↔0	S↔0	S↔0	S↔0	S↔0	S↔0	S↔0	S↔0

## Letra Regular (5 MM) 2.a Línea

POSICIÓN DE LA PERILLA

1	2	3	4	5	6	7	8
1	1	1	.	.	1	1	LB
2	2	2	1	1	2	2	EACH
3	3	3	2	2	3	3	FOOT
4	4	4	3	3	4	4	DOZ
5	5	5	4	4	5	5	YARD
6	6	6	5	5	6	6	PAIR
7	7	7	6	6	7	7	PKG
8	8	8	7	7	8	8	BOX
9	9	9	8	8	9	9	CASE
0	0	0	9	9	0	0	SET
NOW	FOR	FOR	/	/	EACH	OFF	+TX
\$	/	/	-	-	¢	¢	+TX

**ULINE**

800-295-5510  
uline.mx

**ULINE** H-4565

# MONARCH 1136 – PISTOLET À ÉTIQUETTES À DEUX LIGNES

1-800-295-5510  
uline.ca

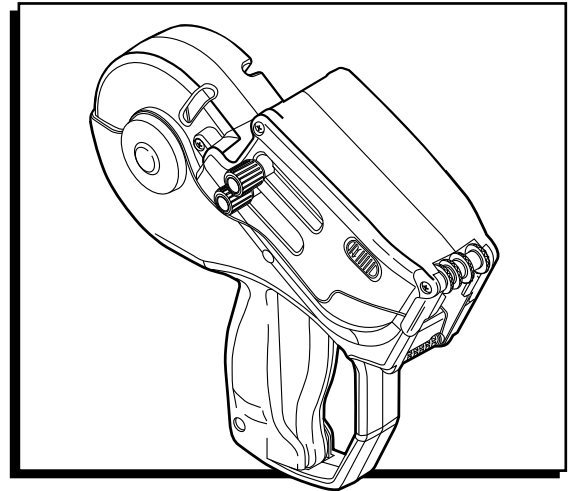

## INSTRUCTIONS

### CHANGEMENT DU ROULEAU ENCREUR

1. Tirez les verrous vers l'arrière et faites pivoter complètement le couvercle en position ouverte. Vous devriez entendre un déclic.

 **REMARQUE : Ne forcez pas le couvercle au-delà de la position d'enclenchement.**

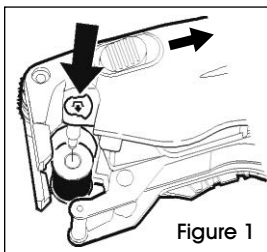

Figure 1

2. Tenez l'étiqueteuse de côté au-dessus d'une poubelle tout en poussant le bouton pour libérer le rouleau encreur. (Voir Figure 1)

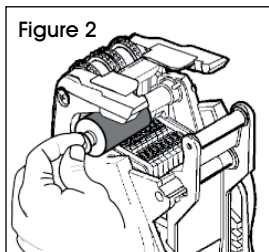

Figure 2

3. Tenez le nouveau rouleau encreur par sa tige. (Voir Figure 2) Faites-le glisser sur le montant, en l'enclenchant en place. (Voir Figure 2)
4. Fermez le couvercle complètement.

### RÉGLAGE DES CARACTÈRES IMPRIMÉS

1. Pour la première ligne, utilisez la légende des caractères sur le dessus du pistolet pour trouver les conversions de caractères alphanumériques.

 **REMARQUE : Voir la légende des caractères à la page 9.**

2. Tirez/poussez sur le bouton jusqu'à ce que les indicateurs soient sur la bande voulue. (Voir Figure 3)
3. Tournez le bouton jusqu'à ce que le caractère souhaité figure entre les indicateurs. Pour imprimer un blanc, sélectionnez l'espace blanc pour la bande. (Voir Figure 3)

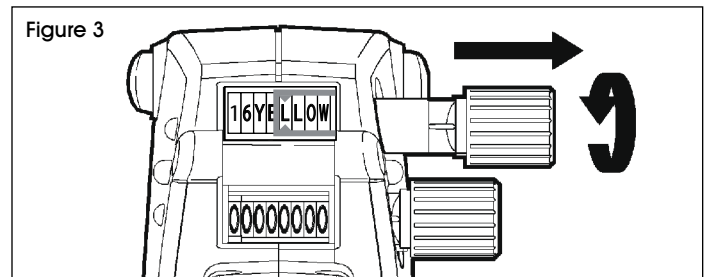

Figure 3

4. Répétez les étapes 2 et 3 pour chaque bande.
5. Enfoncez complètement le bouton lorsque vous avez terminé.
6. Répétez les étapes 2 à 5 pour la seconde ligne.

### CHARGEMENT DES ÉTIQUETTES

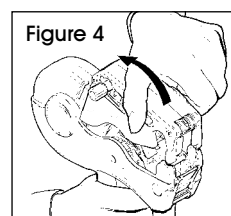

Figure 4

1. Tirez les verrous vers l'arrière et faites pivoter complètement le couvercle en position ouverte. Vous devriez entendre un déclic. (Voir Figure 4)

 **REMARQUE : Ne forcez pas le couvercle au-delà de la position d'enclenchement.**

2. Avant de charger un nouveau rouleau d'étiquettes, arrachez et jetez les 25,4 cm (10 po) initiaux d'étiquettes et de doublure.
3. Ensuite, pour prévenir un bourrage, décollez les 12 premières étiquettes de la doublure et jetez-les.

## INSTRUCTIONS SUITE

### CHARGEMENT DES ÉTIQUETTES SUITE

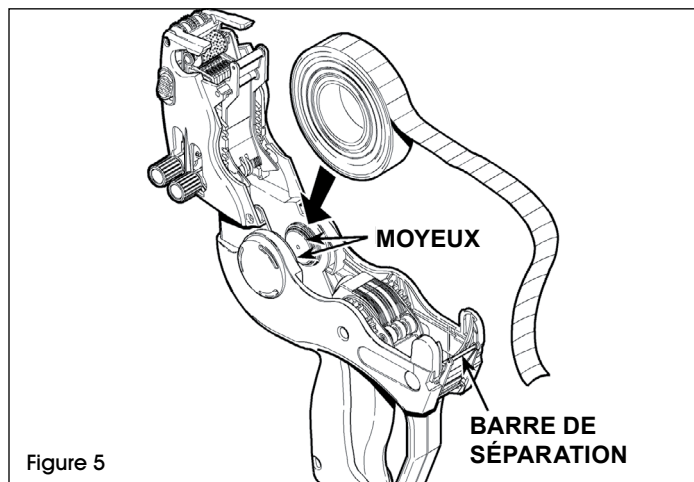

4. Placez le rouleau d'étiquettes entre les moyeux et enclenchez-le. (Voir Figure 5)

 **REMARQUE :** N'enfilez pas la bande d'étiquettes au travers des rouleaux.

5. Déposez la bande d'étiquettes sur l'étiqueteuse et centrez-la sur la barre de séparation. La bande d'étiquettes devrait dépasser de 12,7 à 15,2 cm (5 à 6 po) au-delà de la barre de séparation.
6. Fermez le couvercle.
7. Pressez et maintenez la détente enfoncée tout en alimentant la bande d'étiquettes sous le rouleau et jusque dans la grande fente au-dessus de la flèche, jusqu'à ce qu'elle s'arrête ou atteigne l'arrière. (Voir Figure 6)
8. Maintenez la bande en place et appuyez sur la détente huit fois ou jusqu'à ce que la bande d'étiquettes émerge de la sortie arrière.
9. Enlevez toute étiquette lâche.

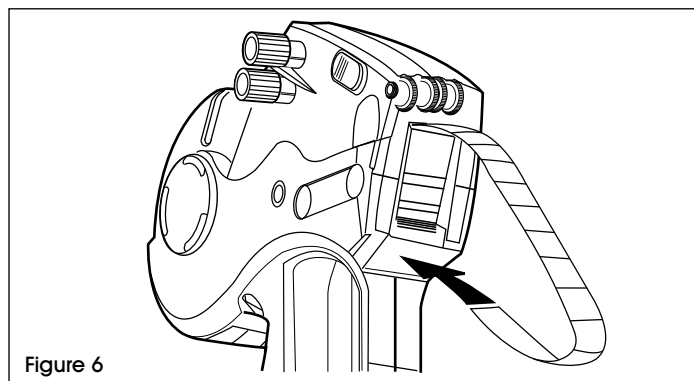

### DÉGAGEMENT DES BOURRAGES, NETTOYAGE ET LUBRIFICATION

1. Ouvrez le couvercle et retirez le rouleau d'étiquettes.
2. Enlevez toute étiquette lâche à l'intérieur de l'étiqueteuse. (Voir Figure 7)

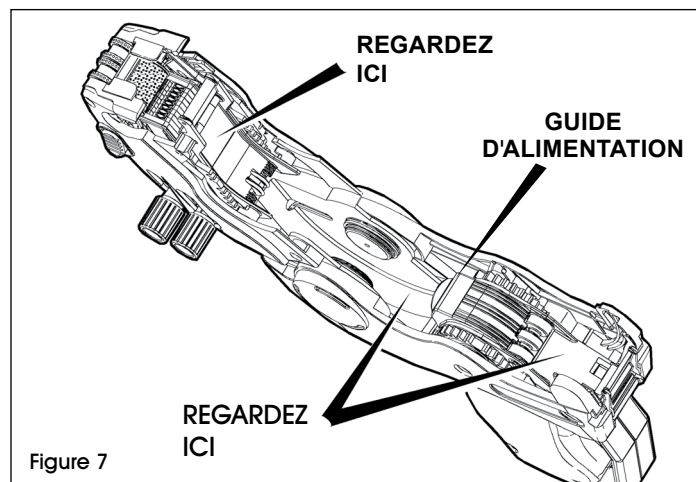

3. Tirez sur le guide d'alimentation pour exposer le chemin du papier support et retirez les étiquettes lâches. (Voir Figure 8)
4. Encliquez le guide d'alimentation dans sa position originale.

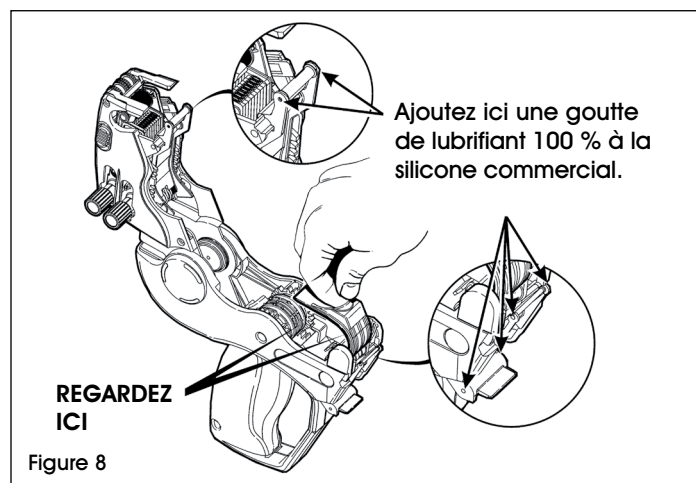

5. Utilisez un solvant commercial pour adhésif afin de nettoyer l'accumulation d'adhésif.
6. Retirez le rouleau encreur pour exposer les bandes d'impression, et nettoyez-les avec une brosse à dents.
7. Rechargez, puis fermez le couvercle.



# LÉGENDE DES CARACTÈRES

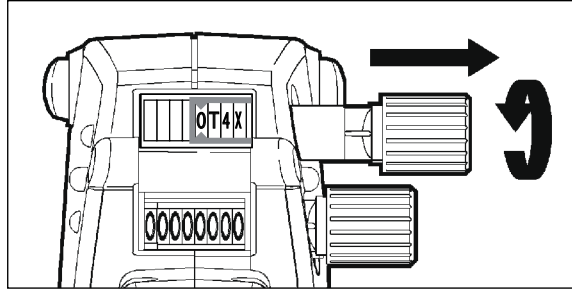

**ROUE DE 1<sup>RE</sup> LIGNE :** Caractères opposés à ceux de la roue. (Exemple : si vous souhaitez imprimer « SALE » sur l'étiquette adhésive, sélectionnez « OT4X ».) Voir les tables de conversion ci-dessous.

## Police de caractères ordinaires (5 MM) 1<sup>re</sup> ligne

POSITION DU BOUTON

1 2 3 4 5 6 7 8

A↔T	A↔T	A↔T	A↔T	A↔T	A↔T	A↔T	A↔T
B↔U	B↔U	B↔U	B↔U	B↔U	B↔U	B↔U	B↔U
C↔V	C↔V	C↔V	C↔V	C↔V	C↔V	C↔V	C↔V
D↔W	D↔W	D↔W	D↔W	D↔W	D↔W	D↔W	D↔W
E↔X	E↔X	E↔X	E↔X	E↔X	E↔X	E↔X	E↔X
F↔Y	F↔Y	F↔Y	F↔Y	F↔Y	F↔Y	F↔Y	F↔Y
G↔Z	G↔Z	G↔Z	G↔Z	G↔Z	G↔Z	G↔Z	G↔Z
H↔I	H↔I	H↔I	H↔I	H↔I	H↔I	H↔I	H↔I
J↔2	J↔2	J↔2	J↔2	J↔2	J↔2	J↔2	J↔2
K↔3	K↔3	K↔3	K↔3	K↔3	K↔3	K↔3	K↔3
L↔4	L↔4	L↔4	L↔4	L↔4	L↔4	L↔4	L↔4
M↔5	M↔5	M↔5	M↔5	M↔5	M↔5	M↔5	M↔5
N↔6	N↔6	N↔6	N↔6	N↔6	N↔6	N↔6	N↔6
P↔7	P↔7	P↔7	P↔7	P↔7	P↔7	P↔7	P↔7
Q↔8	Q↔8	Q↔8	Q↔8	Q↔8	Q↔8	Q↔8	Q↔8
R↔9	R↔9	R↔9	R↔9	R↔9	R↔9	R↔9	R↔9
S↔0	S↔0	S↔0	S↔0	S↔0	S↔0	S↔0	S↔0

READ/PRINT  
PRINT/READ  
READ/PRINT  
PRINT/READ  
READ/PRINT  
PRINT/READ  
READ/PRINT  
PRINT/READ  
READ/PRINT  
PRINT/READ  
READ/PRINT  
PRINT/READ  
READ/PRINT  
PRINT/READ  
READ/PRINT  
PRINT/READ  
READ/PRINT  
PRINT/READ

## Police de caractères ordinaires (5MM) 2<sup>e</sup> ligne

POSITION DU BOUTON

1 2 3 4 5 6 7 8

1	1	1	.	.	1	1	LB
2	2	2	1	1	2	2	EACH
3	3	3	2	2	3	3	FOOT
4	4	4	3	3	4	4	YARD
5	5	5	4	4	5	5	DOZ
6	6	6	5	5	6	6	PAIR
7	7	7	6	6	7	7	PKG
8	8	8	7	7	8	8	BOX
9	9	9	8	8	9	9	CASE
0	0	0	9	9	0	0	SET
NOW	FOR	FOR	/	/	EACH	OFF	+TX
\$	/	/	-	-	↻	↻	+TX

**ULINE**

1-800-295-5510  
uline.ca