

# ULINE H-4607, H-6746 COMPUTER CART

1-800-295-5510  
uline.com

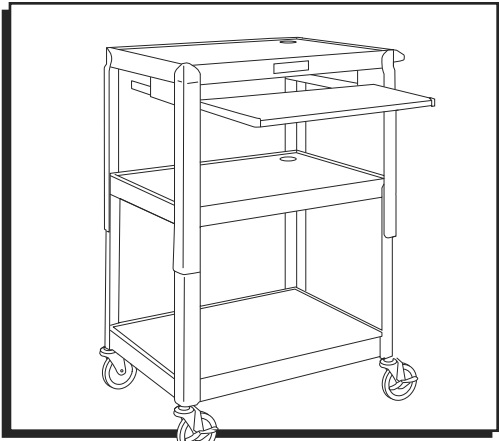

## TOOLS NEEDED

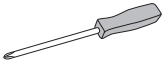

Phillips Screwdriver



Rubber Mallet



Pliers



Allen Wrench  
(included)

## PARTS

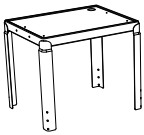

Top Shelf x 1

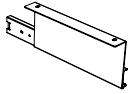

Left Tray Bracket x 1

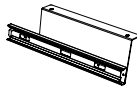

Right Tray Bracket x 1



1/2" Bolt x 4



Locknut x 4

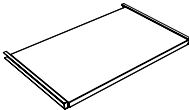

Keyboard Tray x 1



Non-Slip Mat x 1

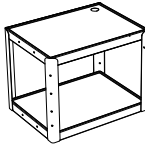

Bottom Shelf x 1



Swivel Caster x 2



Swivel Caster  
with Brake x 2

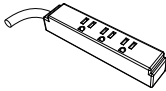

Power Strip x 1

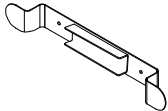

Cord Wrap Bracket x 1



1 1/2" Bolt x 2



Wing Nut x 2



Nut x 4



3/4" Bolt x 4

## ASSEMBLY

### KEYBOARD TRAY ASSEMBLY

1. Place the top shelf upside down on a flat surface. (See Figure 1)
2. Insert 1/2" bolts through the holes in the top shelf and right and left tray brackets. Use screwdriver and pliers to fasten with locknuts. Do not fully tighten.

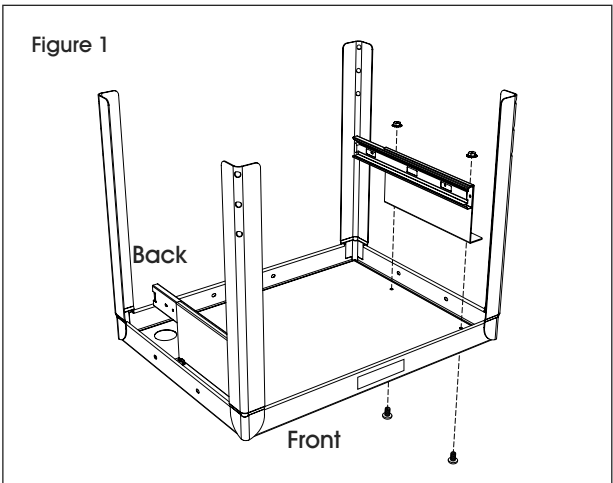

## ASSEMBLY CONTINUED

- Slide keyboard tray into tray brackets and snap into place. (See Figure 2)

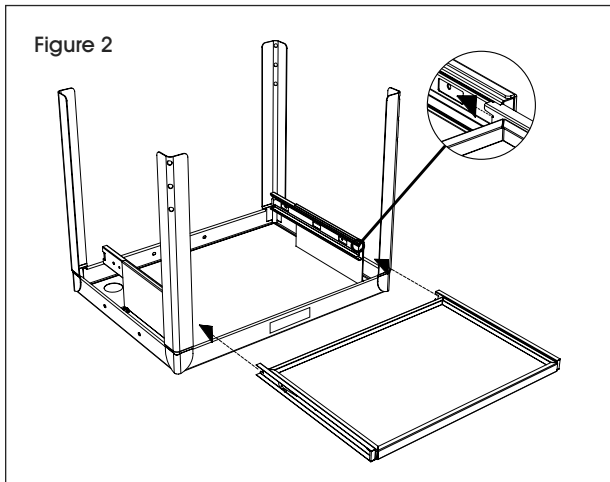

- Pull keyboard tray out to ensure it is properly installed.
- Tighten 1/2" bolts and locknuts.

### CART ASSEMBLY

- Place bottom shelf upside down on a flat surface with caster holes facing up. Insert casters into caster holes and secure with rubber mallet. (See Figure 3)



**NOTE:** Be sure to install the swivel casters with brakes on the front side of the cart.

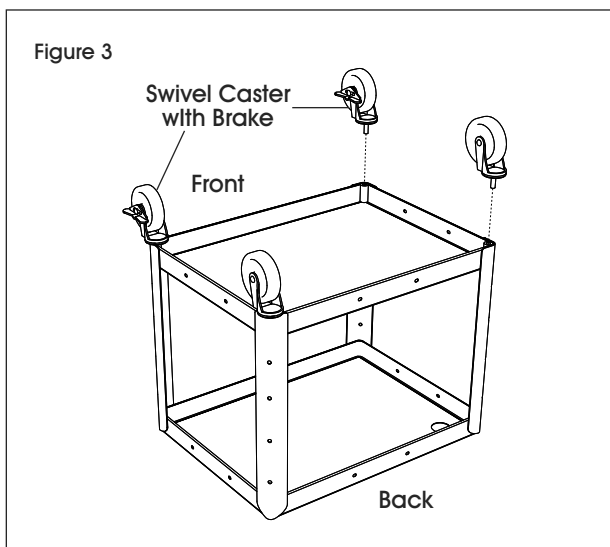

- Turn bottom shelf on its side. (See Figure 4)

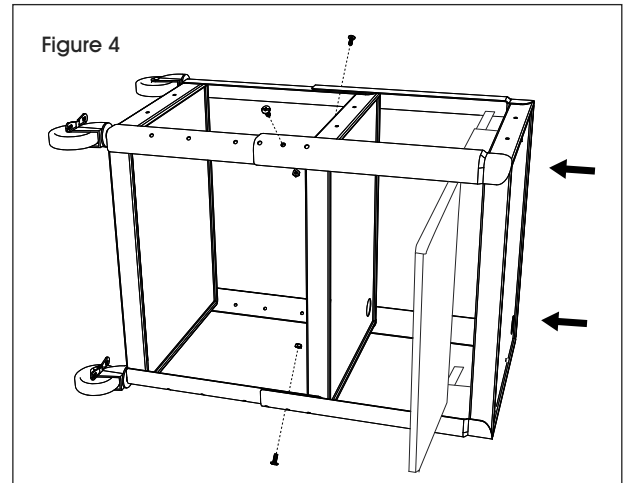

- Slide top shelf over bottom shelf, overlapping the uprights to desired overall cart height. (See Figure 4)
- With holes aligned, insert 3/4" bolts. Use Allen wrench and pliers to fasten with nuts. (See Figure 4)
- Stand cart up and place non-slip mat on top shelf.

### POWER STRIP ASSEMBLY

- Insert 1/2" bolts through cord wrap bracket and into top shelf. (See Figure 5)
- Secure bolts with wing nuts using Phillips screwdriver. (See Figure 5)

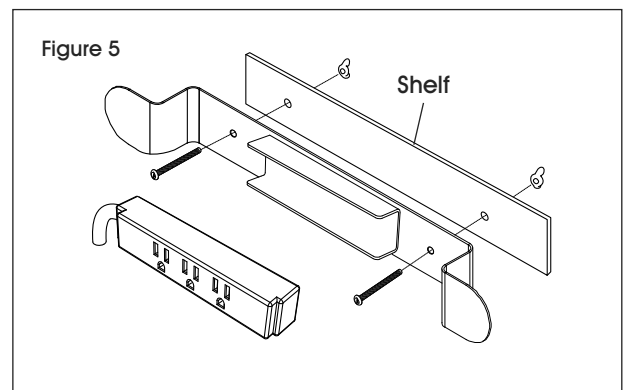

- Snap power strip into bracket.

**ULINE**

1-800-295-5510  
uline.com

**ULINE** H-4607, H-6746

800-295-5510  
uline.mx

## CARRITO PARA COMPUTADORA

### HERRAMIENTAS NECESARIAS

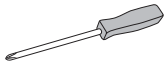

Desarmador Phillips



Mazo de Hule

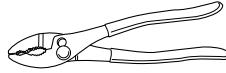

Pinzas



Llave Allen  
(incluida)

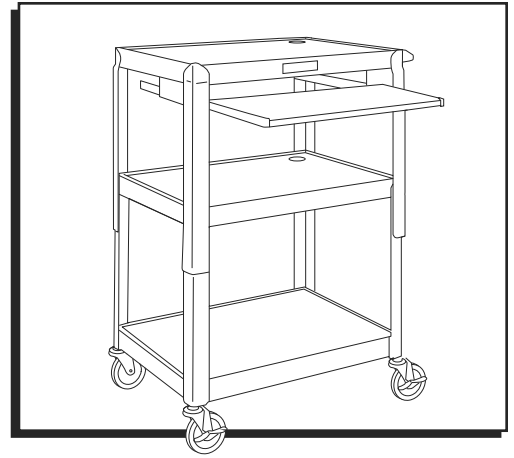

### PARTES

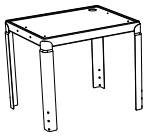

1 Repisa Superior

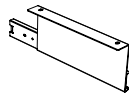

1 Soporte Izquierdo para Bandeja

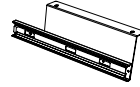

1 Soporte Derecho para Bandeja



4 Pernos de 1/2"



4 Tuercas de Seguridad

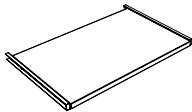

1 Bandeja para Teclado



1 Tapete Antideslizante

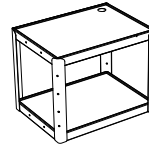

1 Repisa Inferior



2 Ruedas Giratorias



2 Ruedas Giratorias con Freno

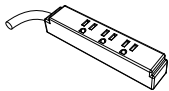

1 Extensión Eléctrica

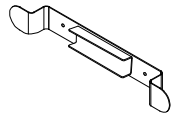

1 Soporte para Envoltura de Cable



2 Pernos de 1 1/2"



2 Tuercas de Alas



4 Tuercas



4 Pernos de 3/4"

### ENSAMBLE

#### ENSAMBLE DE LA BANDEJA PARA TECLADO

1. Coloque la repisa superior boca abajo sobre una superficie plana. (Vea Diagrama 1)
2. Inserte los pernos de 1/2" a través de los orificios de la repisa superior y de los soportes para bandeja derecho e izquierdo. Use un desarmador y unas pinzas para apretar las tuercas de seguridad. No las apriete completamente.

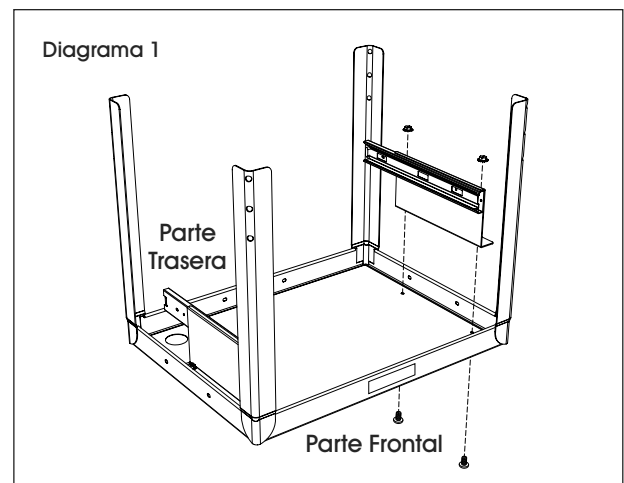

## CONTINUACIÓN DE ENSAMBLE

3. Deslice la bandeja para teclado por los soportes para bandeja hasta que se ajusten en su lugar. (Vea Diagrama 2)

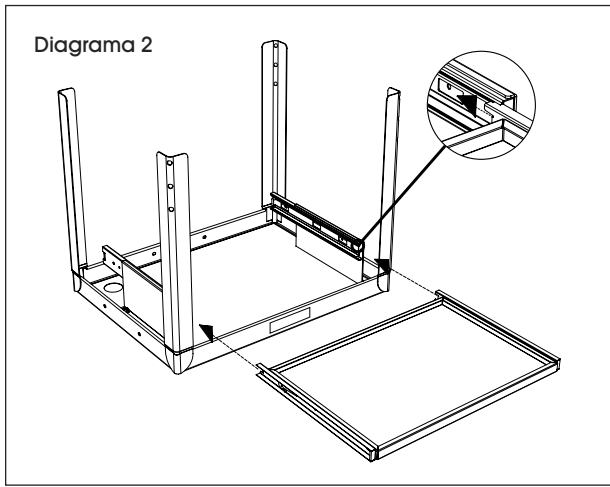

4. Jale la bandeja para teclado para asegurarse de que está adecuadamente instalada.
5. Apriete los pernos de 1/2" y las tuercas de seguridad.

### ENSAMBLE DEL CARRITO

1. Coloque la repisa inferior boca abajo sobre una superficie plana con los orificios para las ruedas hacia arriba. Inserte las ruedas en los orificios correspondientes y fíjelas con un mazo de hule. (Vea Diagrama 3)

 **NOTA:** Asegúrese de instalar las ruedas giratorias con frenos en la parte delantera del carrito.

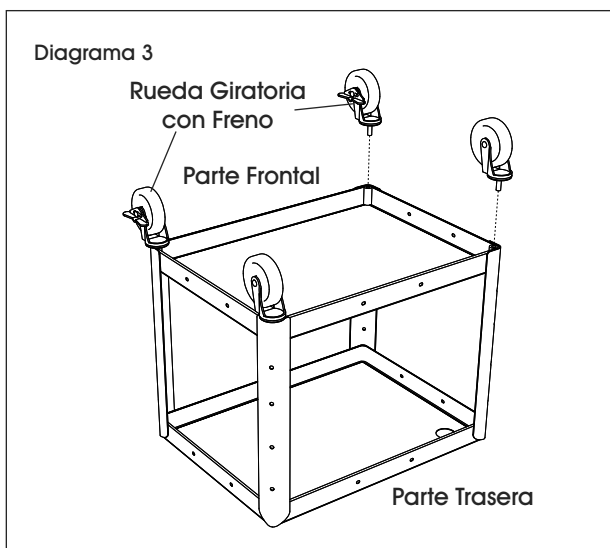

2. Apoye la repisa inferior sobre uno de sus lados. (Vea Diagrama 4)

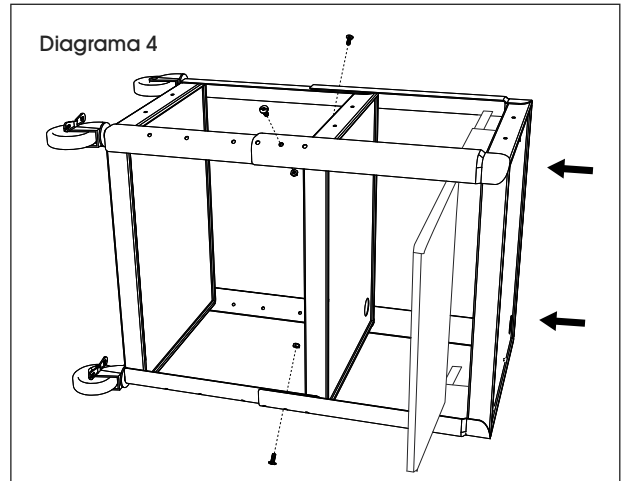

3. Deslice la repisa superior sobre la repisa inferior, solapando los marcos verticales hasta la altura total deseada del carrito. (Vea Diagrama 4)
4. Con los orificios alineados, inserte los pernos de 3/4". Use un desarmador y unas pinzas para apretar las tuercas. (Vea Diagrama 4)
5. Coloque el carrito en posición vertical y coloque el tapete antideslizante en la repisa superior.

### ENSAMBLE DEL MULTICONTACTO

1. Inserte pernos de 1 1/2" a través del soporte para envoltura del cable y la repisa superior. (Vea Diagrama 5)
2. Asegure los pernos con las tuercas de mariposa usando un desarmador de cruz. (Vea Diagrama 5)

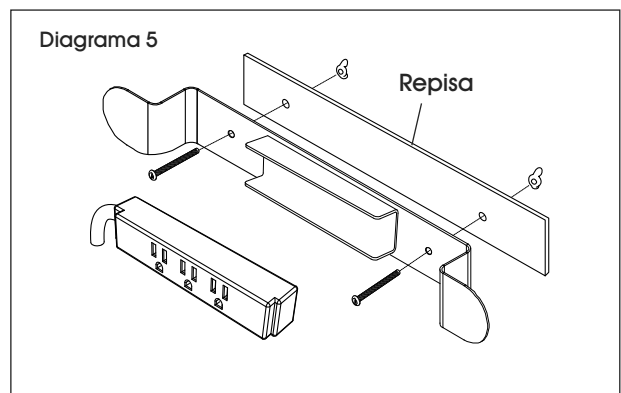

3. Introduzca el multicontacto en el soporte.

**ULINE**

800-295-5510  
uline.mx

# ULINE H-4607, H-6746 CHARIOT INFORMATIQUE

1-800-295-5510  
uline.ca

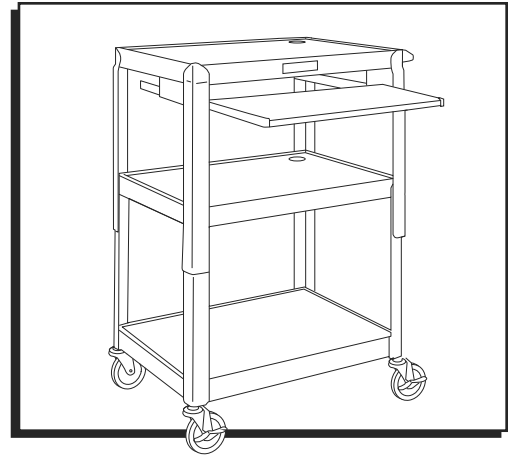

## OUTILS REQUIS

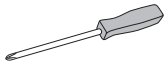

Tournevis cruciforme



Maillet en caoutchouc

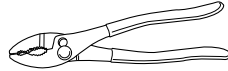

Pinces



Clé Allen  
(incluse)

## PIÈCES

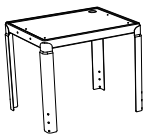

Tablette supérieure x 1

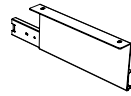

Support du plateau  
gauche x 1

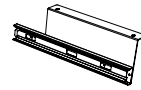

Support du plateau droit x 1



Boulon de 1,3 cm  
(1/2 po) x 4



Écrou  
autobloquant x 4

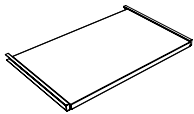

Plateau à clavier x 1

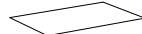

Tapis antidérapant x 1

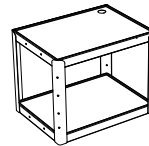

Tablette inférieure x 1



Roulette pivotante x 2



Roulette pivotante  
avec frein x 2

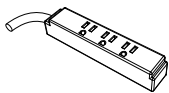

Barre multiprise x 1

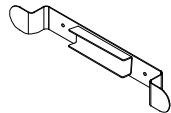

Support pour  
l'enroulement du  
cordon x 1



Boulon de 3,8 cm  
(1 1/2 po) x 2



Écrou à oreilles x 2



Écrou x 4



Boulon de 1,9 cm  
(3/4 po) x 4

## MONTAGE

### MONTAGE DU PLATEAU À CLAVIER

1. Déposez la tablette supérieure à l'envers sur une surface plane. (Voir Figure 1)
2. Insérez des boulons de 1,3 cm (1/2 po) dans les trous de la tablette supérieure et dans les supports droit et gauche du plateau. Utilisez un tournevis et des pinces pour fixer avec des écrous autobloquants. Ne serrez pas complètement.

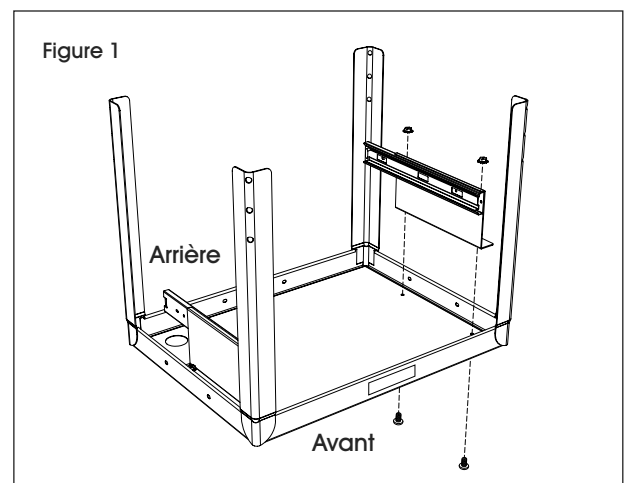

## MONTAGE SUITE

3. Faites glisser le plateau à clavier dans les supports de plateau et enclenchez-les ensemble. (Voir Figure 2)

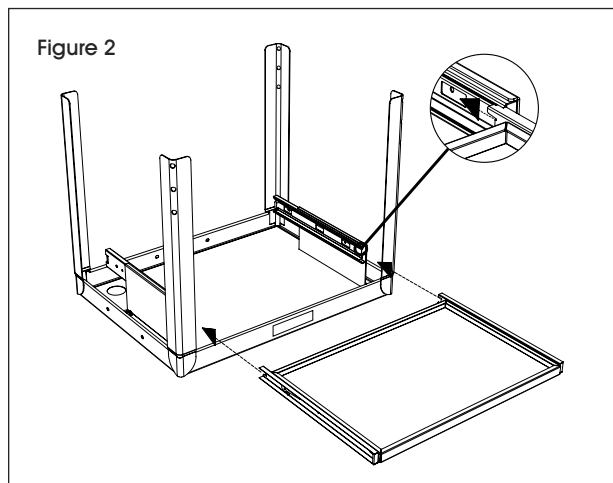

4. Alignez les trous, puis insérez les boulons de 3/4 po. Utilisez la clé Allen et des pinces pour fixer avec des écrous. (Voir Figure 2)
5. Serrez les boulons de 1,3 cm (1/2 po) et les écrous autobloquants.

### MONTAGE DU CHARIOT

1. Placez la tablette inférieure à l'envers sur une surface plane avec les trous des roulettes orientés vers le haut. Insérez les roulettes dans les trous pour roulette et fixez à l'aide du maillet en caoutchouc. (Voir Figure 3)

 **REMARQUE :** Assurez-vous d'installer les roulettes pivotantes verrouillables à l'avant du chariot.

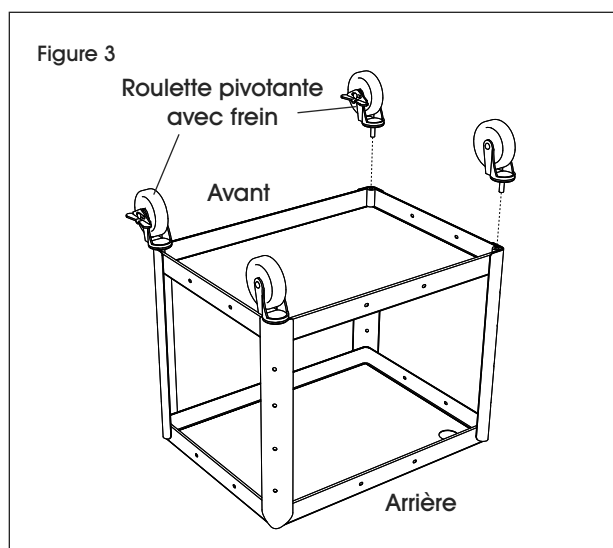

2. Tournez la tablette inférieure sur le côté. (Voir Figure 4)

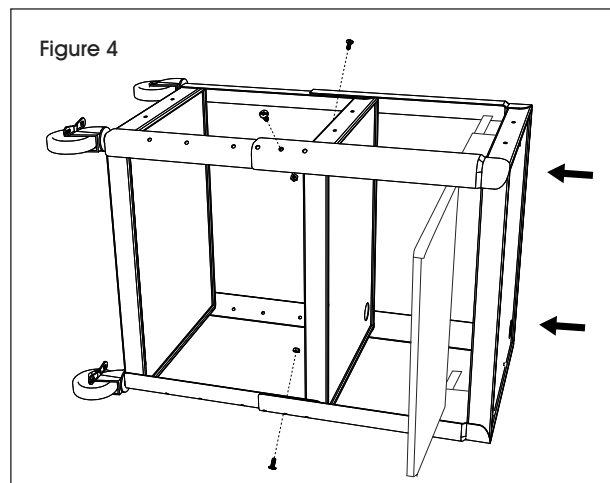

3. Glissez la tablette supérieure au-dessus de la tablette inférieure, en faisant chevaucher les barres latérales à la hauteur désirée du chariot. (Voir Figure 4)
4. Alignez les trous, puis insérez les boulons de 3/4 po. Utilisez la clé Allen et des pinces pour fixer avec des écrous. (Voir Figure 4)
5. Redressez le chariot et placez le tapis antidérapant sur la tablette supérieure.

### MONTAGE DE LA BARRE MULTIPRISE

1. Insérez les boulons de 1 1/2 po à travers le support pour l'enroulement du cordon, puis dans la tablette supérieure. (Voir Figure 5)
2. Fixez les boulons à l'aide d'un tournevis cruciforme et les écrous à oreilles. (Voir Figure 5)

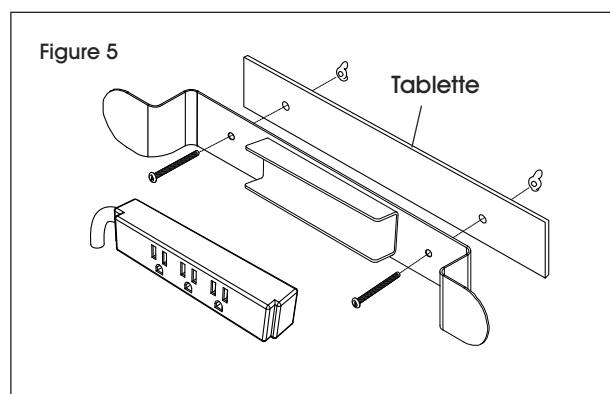

3. Encliquez la barre multiprise dans le support.

**ULINE**

1-800-295-5510  
uline.ca