

ULINE H-4701 SLIMFOLD™ TOWEL DISPENSER

1-800-295-5510
uline.com

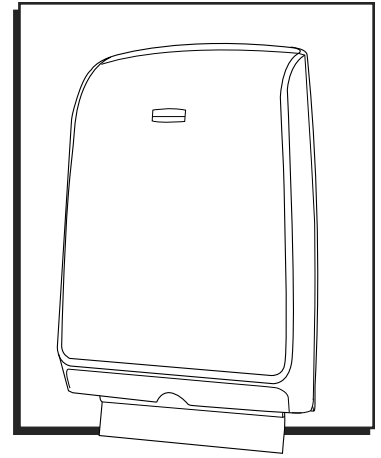

TOOLS NEEDED



Drill



1/4" Drill Bit

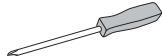

Phillips Screwdriver



Level

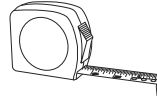

Tape Measure

PARTS

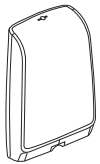

Dispenser x 1

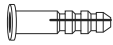

Wall Anchor x 4



Screw x 4



Dispenser Key x 1



Wet Wipe x 1



Adhesive Strip x 3

OPTIONAL PUSH BUTTON INSTRUCTIONS

1. Remove push button from inside dispenser. (See Figure 1)

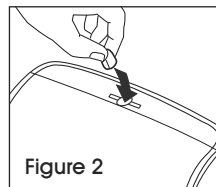
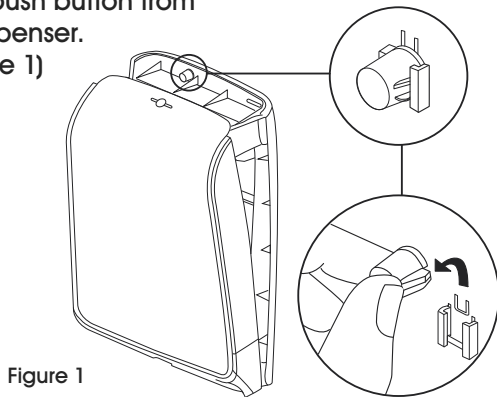

Figure 2

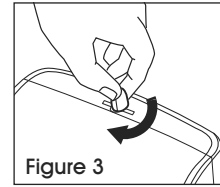

Figure 3

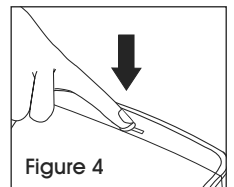

Figure 4

2. Push button down into opening on top of dispenser. (See Figure 2)
3. Turn button to lock it in place. (See Figure 3)
4. Push button to open dispenser without requiring key. (See Figure 4)

MOUNTING INSTRUCTIONS



NOTE: Ensure that proper mounting hardware is used for appropriate wall composition, as enclosed hardware may not be compatible with wall surface.

MOUNTING WITH SCREWS



NOTE: Recommended mounting height is 52" from the floor to bottom of dispenser.

1. Insert dispenser key into hole in top of dispenser and turn counterclockwise to unlock. (See Figure 5)
2. Open dispenser cover and hold dispenser to ideal mounting place on wall. (See Figure 6)

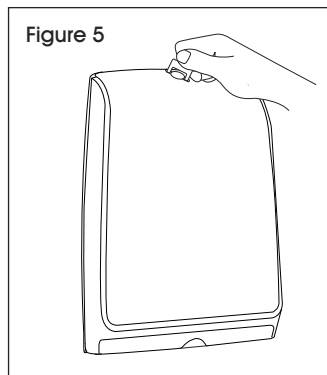

Figure 5

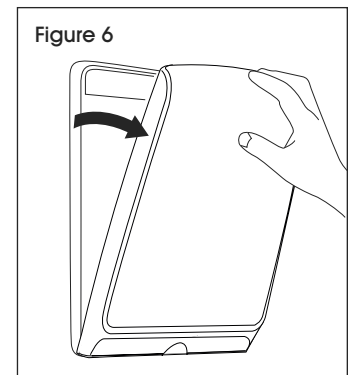
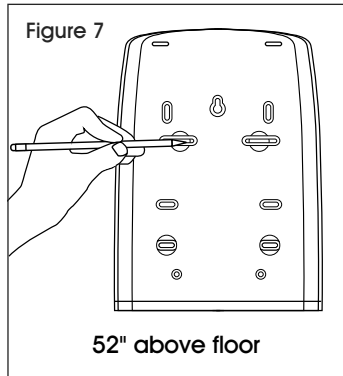

Figure 6

MOUNTING INSTRUCTIONS CONTINUED

MOUNTING WITH SCREWS CONTINUED

3. Mark the four holes on the wall where screws will be inserted using template included in box or by holding the dispenser against the wall. (See Figure 7)



4. Drill into wall at four marked locations with a 1/4" drill bit. (See Figure 8) Insert anchors into wall (if applicable).

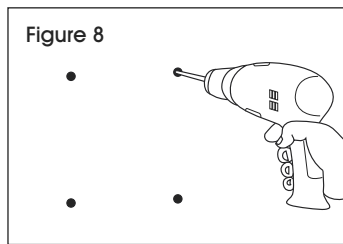

5. Hold dispenser to mounting place and insert screws into previously drilled holes using either a screwdriver or a drill. (See Figure 9)

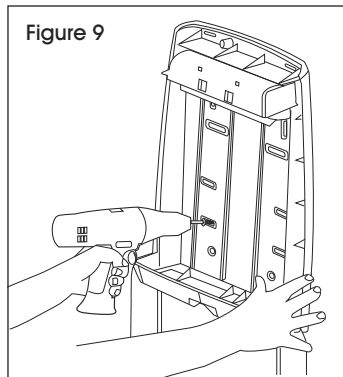

MOUNTING WITH ADHESIVE

1. Open wet wipe from hardware pack. (See Figure 10)

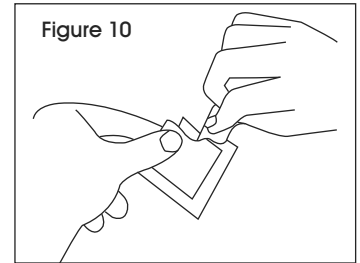

2. Wipe back of dispenser and wall with wet wipe. (See Figures 11 and 12)

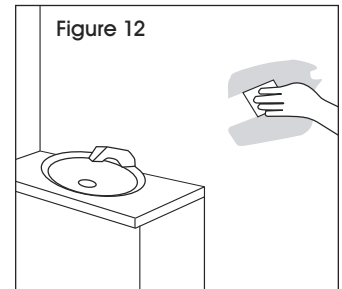
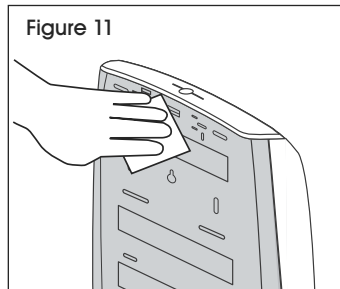

3. Remove backing from adhesive strips. (See Figure 13)

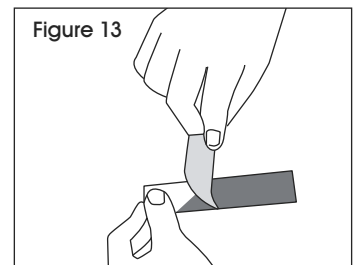

4. Place three strips on back of dispenser and mount on wall. (See Figures 14-15)

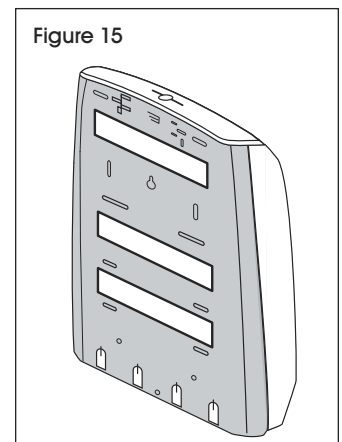
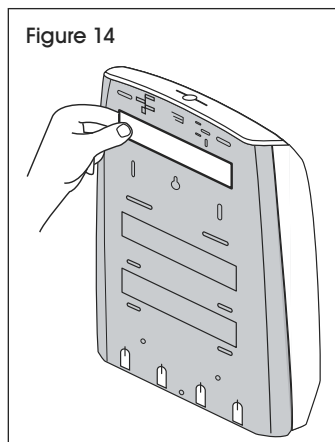

LOADING INSTRUCTIONS

1. Remove wrap from bundle of towels. Load towels into dispenser. (See Figures 16-17)

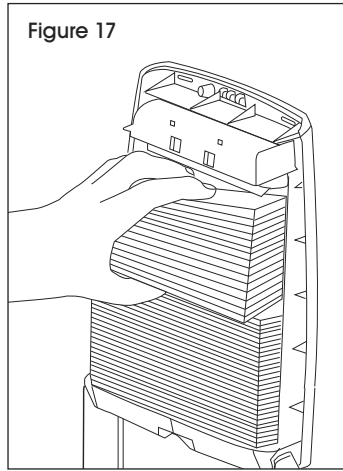
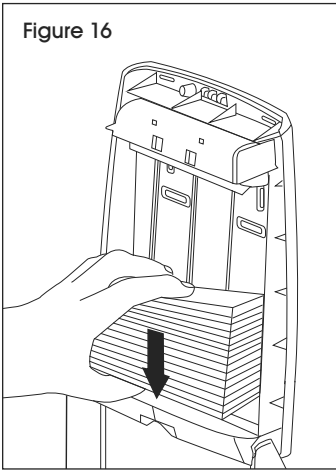

3. Close dispenser and pull first towel out to begin dispensing. (See Figures 19-20)

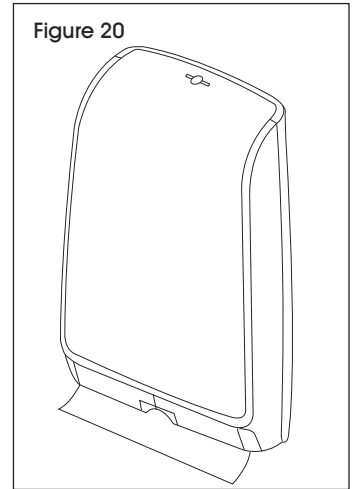
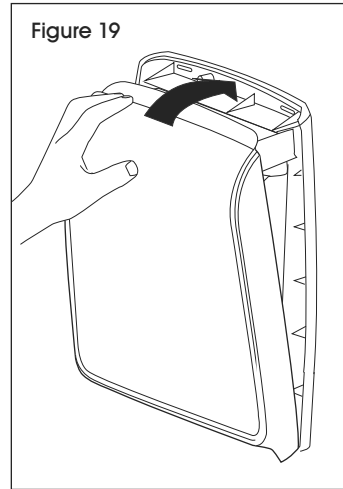

2. Do not compress the towels or overload dispenser. (See Figure 18)

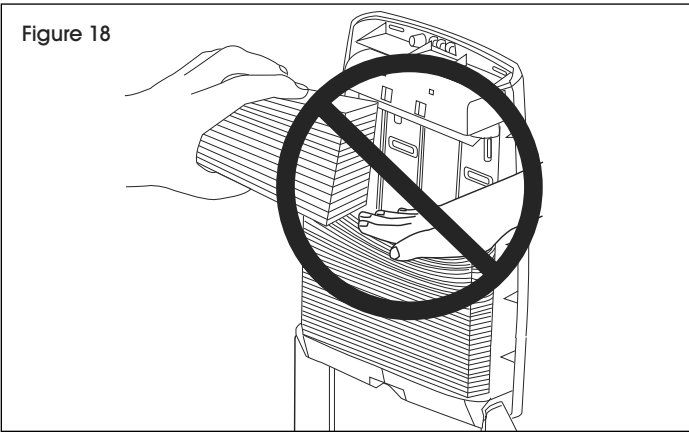

ULINE

1-800-295-5510
uline.com

ULINE H-4701

SLIMFOLD™ DESPACHADOR DE TOALLAS

800-295-5510

uline.mx

HERRAMIENTAS NECESARIAS



Taladro



1/4" Broca

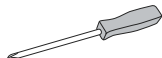

Desarmador de Cruz



Nivel

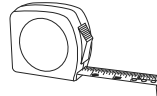

Cinta de Medir

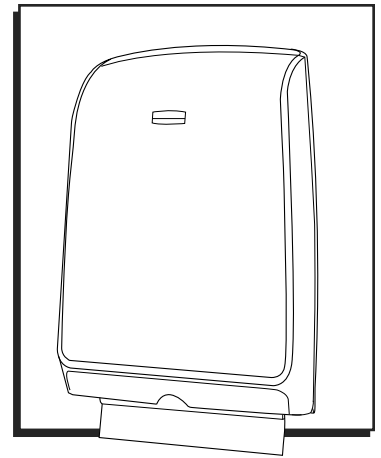

PARTES

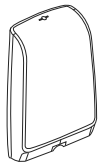

1 Despachador

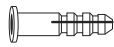

4 Taquetes



4 Tornillos



1 Llave de Despachador



1 Toallita Húmeda



3 Tiras Adhesivas

INSTRUCCIONES DEL BOTÓN PULSADOR OPCIONAL

1. Retire el botón pulsador del interior del despachador. (Vea Diagrama 1)



Diagrama 1



Diagrama 2

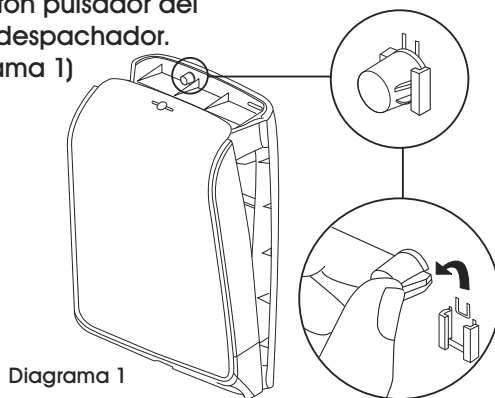

Diagrama 3

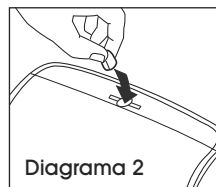

Diagrama 4

2. Empuje el botón pulsador hacia la abertura ubicada en la parte superior del despachador. (Vea Diagrama 2)
3. Gire el botón para fijarlo. (Vea Diagrama 3)
4. Presione el botón para abrir el despachador sin necesidad de usar la llave. (Vea Diagrama 4)

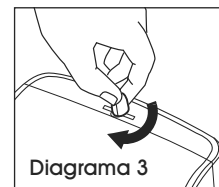
INSTRUCCIONES DE INSTALACIÓN

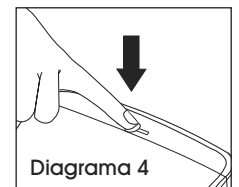

NOTA: Asegúrese de utilizar tornillería de instalación adecuada para la composición de pared apropiada, pues la tornillería que se incluye puede no ser compatible con la superficie de la pared.

INSTALACIÓN CON TORNILLOS



NOTA: La altura de instalación recomendada es de 1.32 m (52") desde el suelo hasta la parte inferior del despachador.

1. Inserte la llave del despachador en el orificio en la parte superior y gírela en sentido contrario a las manecillas del reloj para desbloquearlo. (Vea Diagrama 5)
2. Abra la cubierta del despachador y sujete el despachador sobre la pared hasta el lugar ideal de instalación. (Vea Diagrama 6)



Diagrama 5



Diagrama 6

CONTINUACIÓN INSTRUCCIONES DE INSTALACIÓN

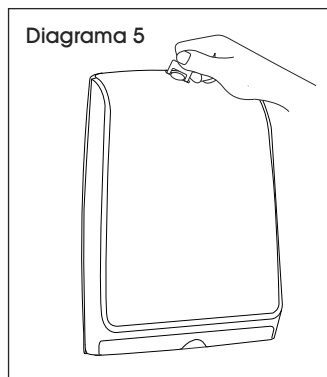
CONTINUACIÓN DE INSTALACIÓN CON TORNILLOS

3. Marque los cuatro orificios de la pared en los que se insertarán los tornillos usando la plantilla que se incluye en la caja o sosteniendo el despachador contra la pared. (Vea Diagrama 7)

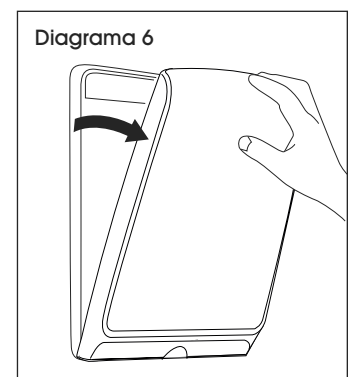
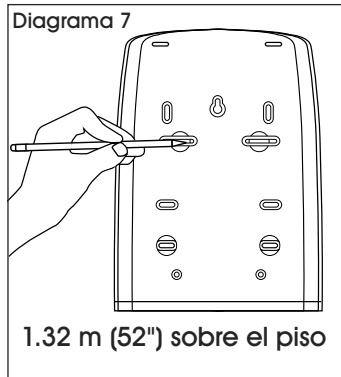

4. Taladre la pared en las cuatro ubicaciones marcadas con una broca de taladro de 0.6 cm (1/4"). Inserte los taquetes en la pared (si aplica).

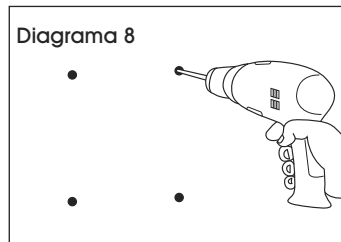

5. Sostenga el despachador contra el lugar de instalación e inserte los tornillos en los orificios taladrados previamente usando un desarmador o un taladro. (Vea Diagrama 9)

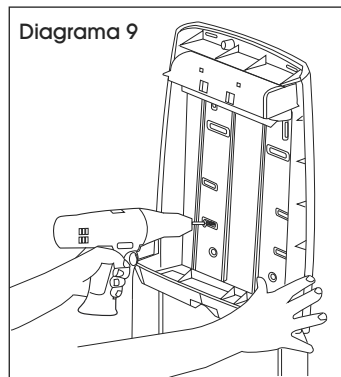

INSTALACIÓN CON ADHESIVO

1. Abra la toallita húmeda del paquete de tornillería. (Vea Diagrama 10)

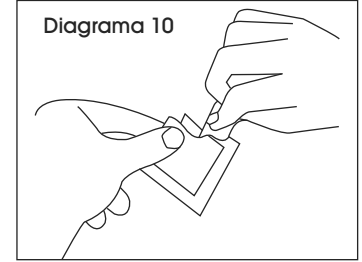

2. Limpie la parte posterior del despachador y la pared con la toallita húmeda. (Vea Diagramas 11 y 12)

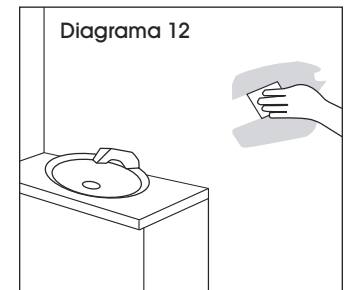
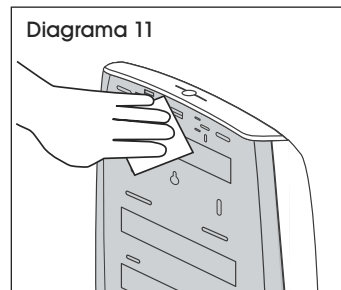

3. Retire el respaldo de las tiras adhesivas. (Vea Diagrama 13)

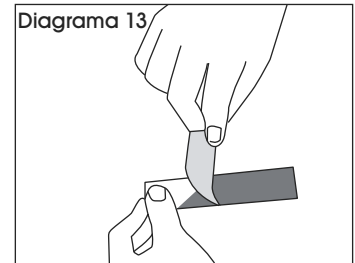

4. Coloque tres tiras en la parte posterior del despachador e instálelo en la pared. (Vea Diagramas 14 a 15)

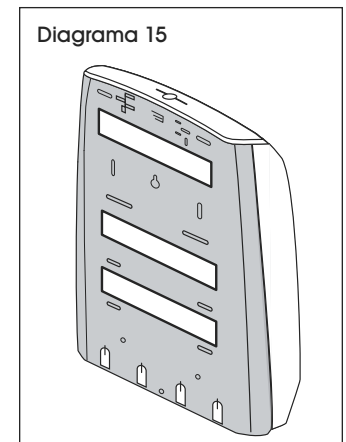
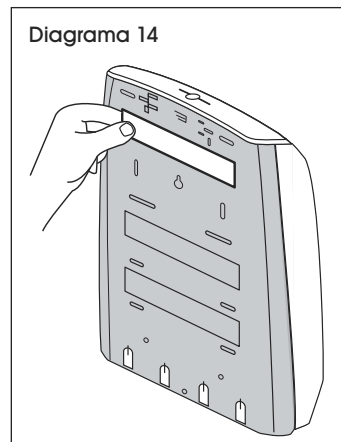

INSTRUCCIONES DE CARGA

1. Retire la envoltura del paquete de toallas. Cargue las toallas en el despachador. (Vea Diagramas 16 y 17)

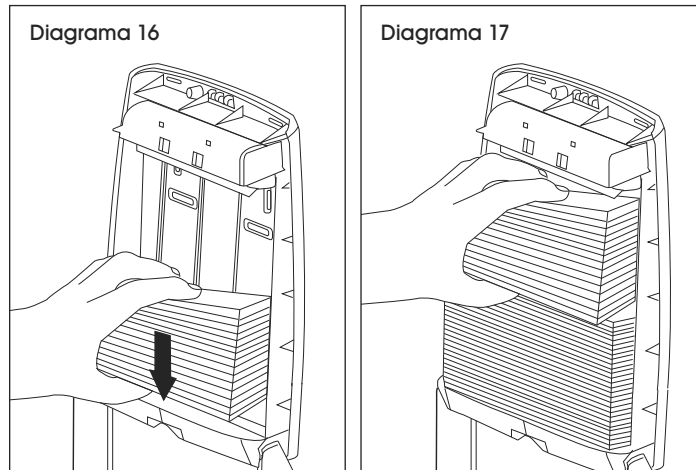

2. No comprima las toallas ni sobrecargue el despachador. (Vea Diagrama 18)

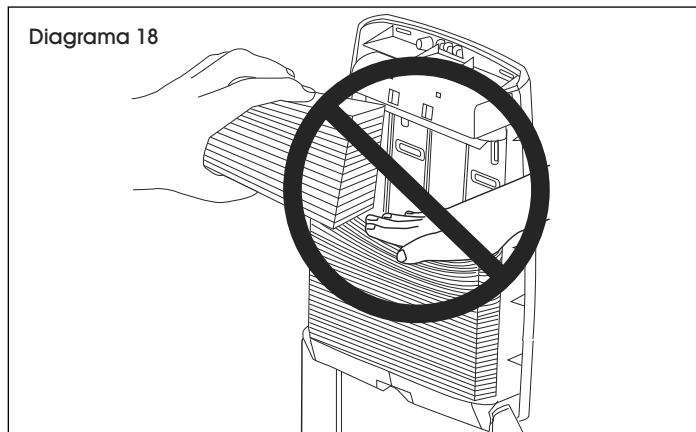

3. Cierre el despachador y jale la primera toalla para comenzar a despachar. (Vea Diagramas 19 y 20)

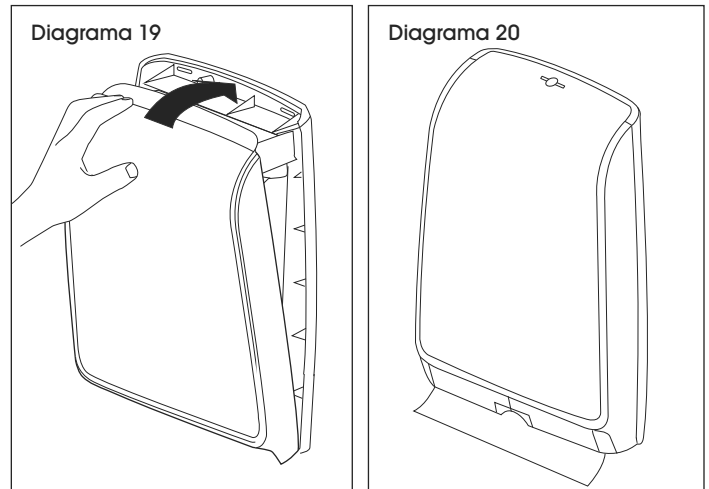

ULINE H-4701

SLIMFOLD^{MC} – DISTRIBUTEUR DE SERVIETTES

1-800-295-5510

uline.ca

OUTILS REQUIS



Perceuse



Mèche de perceuse

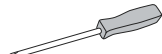

Tournevis cruciforme



Niveau à bulles

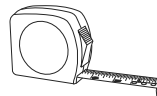

Ruban à mesurer

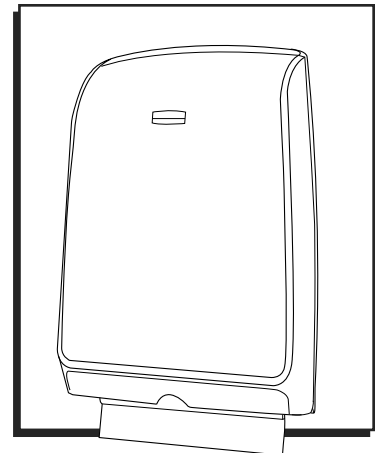

PIÈCES

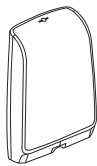

Distributeur x 1

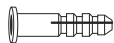

Dispositifs d'ancrage x 4



Vis x 4



Clé de distributeur x 1



Lingette humide x 1



Bande adhésive x 3

BOUTON-POUSOIR FACULTATIF

1. Retirez le bouton-pousoir de l'intérieur du distributeur. (Voir Figure 1)

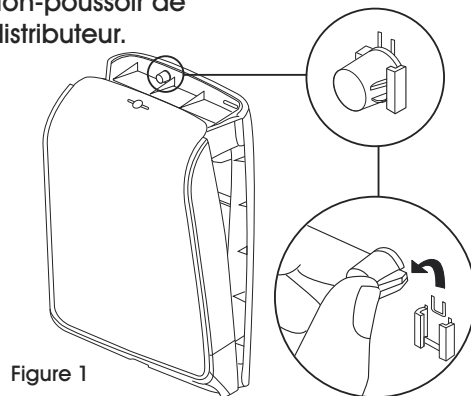

Figure 1

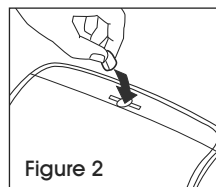

Figure 2

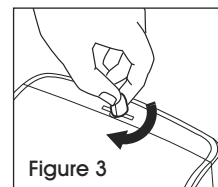

Figure 3

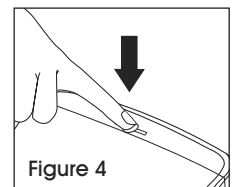



Figure 4

2. Poussez le bouton vers le bas dans l'ouverture en haut du distributeur. (Voir Figure 2)
3. Tournez le bouton pour le verrouiller. (Voir Figure 3)
4. Appuyez sur le bouton pour ouvrir le distributeur sans clé. (Voir Figure 4)

MONTAGE

 **REMARQUE :** Veillez à utiliser un matériel d'installation adéquat adapté à votre mur. Le matériel d'installation fourni pourrait ne pas être compatible avec la surface de votre mur.

MONTAGE À L'AIDE DE VIS

 **REMARQUE :** La hauteur de montage recommandée est de 1,3 m (52 po) du plancher au bas du distributeur.

1. Insérez la clé du distributeur dans le trou en haut du distributeur et tournez dans le sens inverse des aiguilles d'une montre pour déverrouiller. (Voir Figure 5)
2. Ouvrez le couvercle du distributeur et tenez le distributeur à la hauteur de montage désirée sur le mur. (Voir Figure 6)

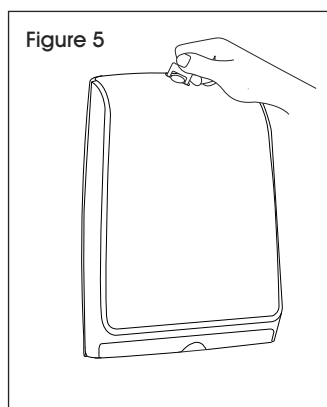

Figure 5

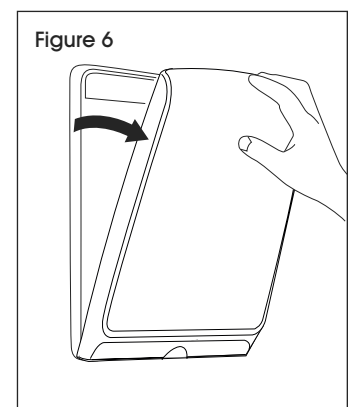
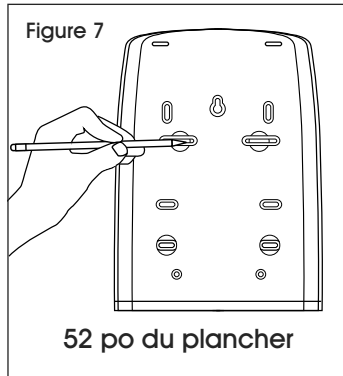

Figure 6

MONTAGE SUITE

MONTAGE À L'AIDE DE VIS SUITE

3. Marquez les quatre trous sur le mur à l'emplacement où les vis seront insérées grâce au modèle contenu dans la boîte ou en maintenant le distributeur contre le mur. (Voir Figure 7)



4. Percez le mur aux quatre emplacements marqués avec une mèche de perceuse de 6,4 mm (1/4 po). (Voir Figure 8) Insérez les dispositifs d'ancrage dans le mur (le cas échéant).

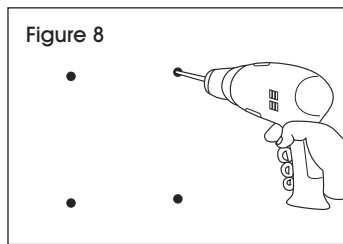

5. Tenez le distributeur à la hauteur de montage et insérez les vis dans les trous prépercés au moyen d'un tournevis ou d'une perceuse. (Voir Figure 9)

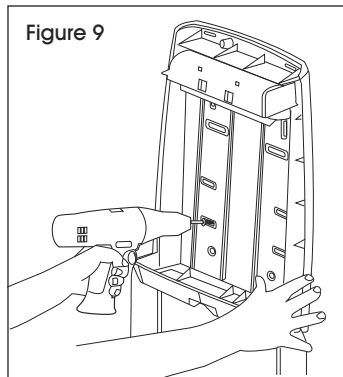

MONTAGE FACULTATIF AVEC ADHÉSIF

1. Sortez une lingette humide du paquet de matériel d'installation. (Voir Figure 10)

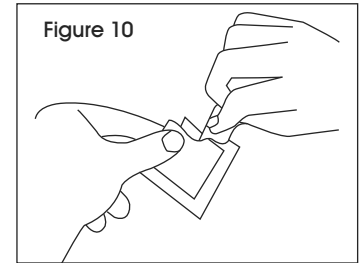

2. Passez la lingette humide à l'arrière du distributeur et sur le mur. (Voir Figures 11 et 12)

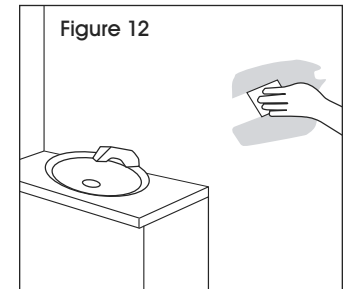
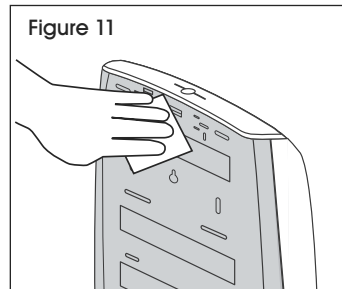

3. Retirez la pellicule des bandes adhésives. (Voir Figure 13)

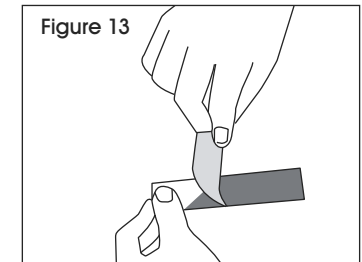

4. Placez trois bandes à l'arrière du distributeur puis fixez-le sur le mur. (Voir Figures 14 et 15)

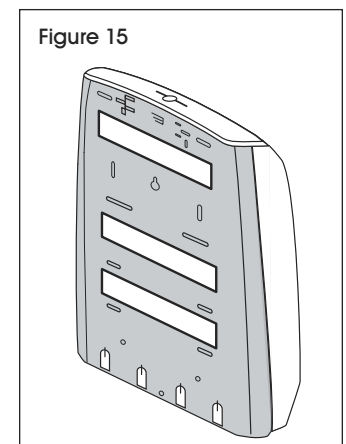
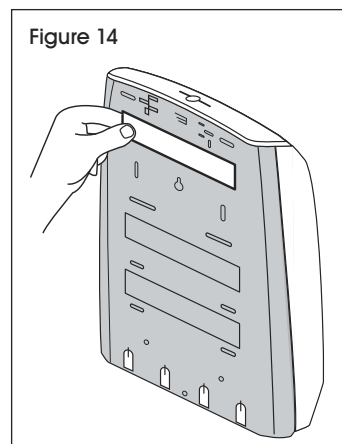

CHARGEMENT

1. Retirez l'emballage recouvrant le paquet de serviettes. Empilez les serviettes dans le distributeur. (Voir Figures 16 et 17)

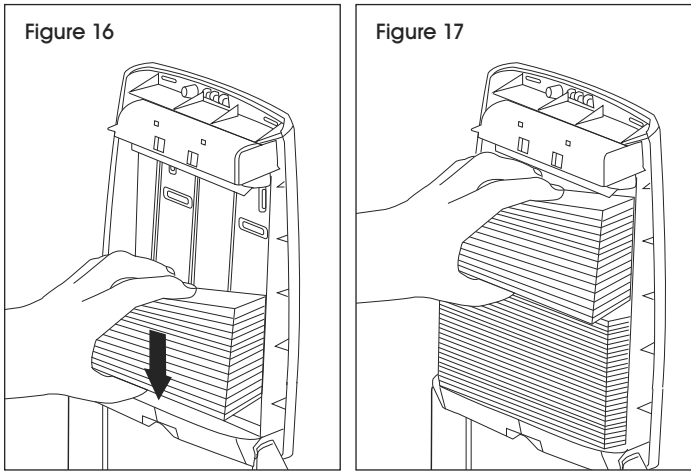

3. Fermez le distributeur et tirez sur la première serviette pour amorcer la distribution. (Voir Figures 19 et 20)

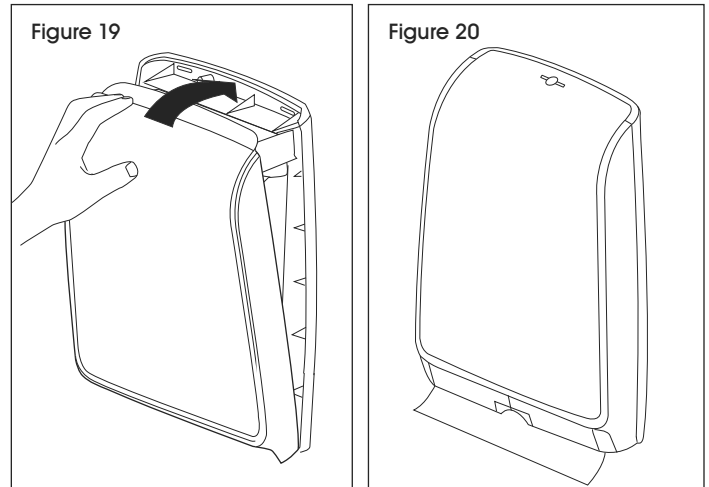

2. Ne compressez pas les serviettes et ne surchargez pas le distributeur. (Voir Figure 18)

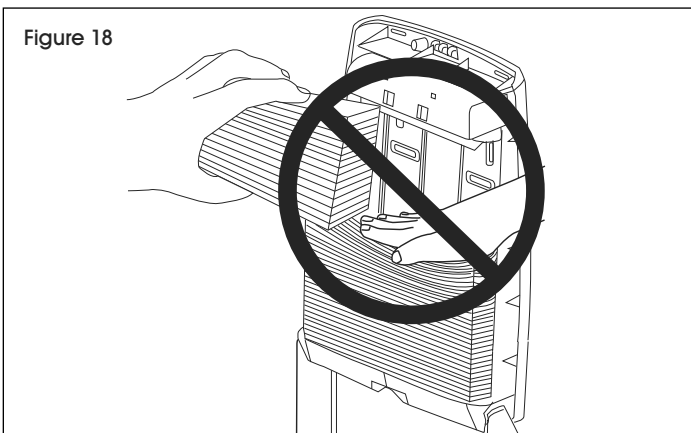

ULINE

1-800-295-5510
uline.ca