

ULINE H-4786 PURELL® ELITE TFX™ DISPENSER STAND

1-800-295-5510
uline.com

TOOL NEEDED



Allen Wrench
(included)

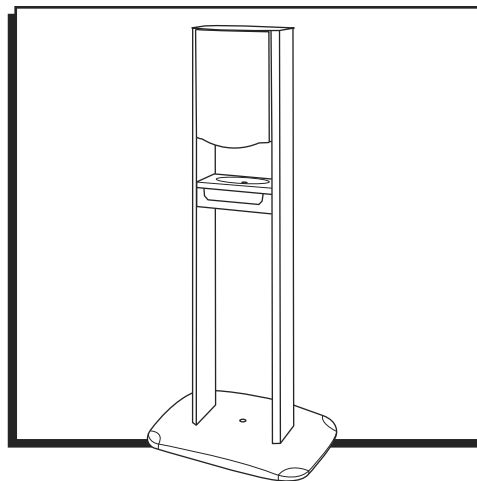

PARTS

Figure 1

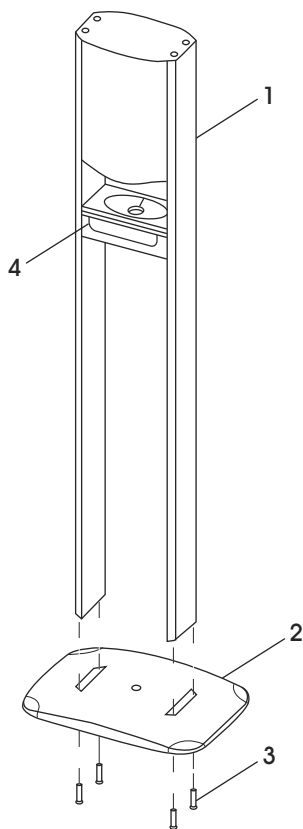

#	DESCRIPTION	QTY.
1	Stand	1
2	Base	1
3	Screw	4
4	Bin	2

ASSEMBLY

1. Attach the stand to the base using screws and Allen wrench provided. (See Figure 1)



NOTE: The pump remains active when the door is opened. A spare bin is provided. (See Figure 2)

Figure 2

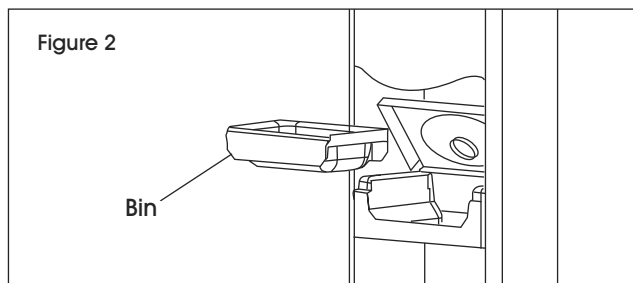

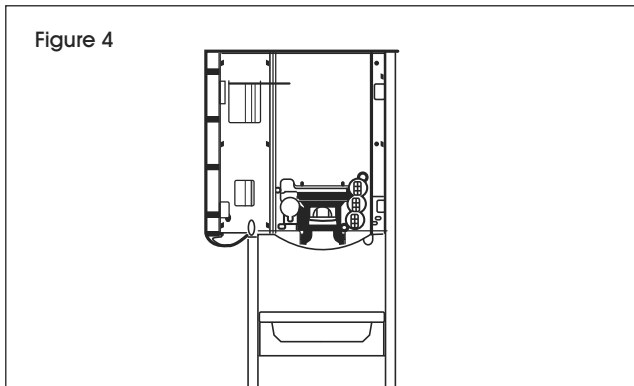
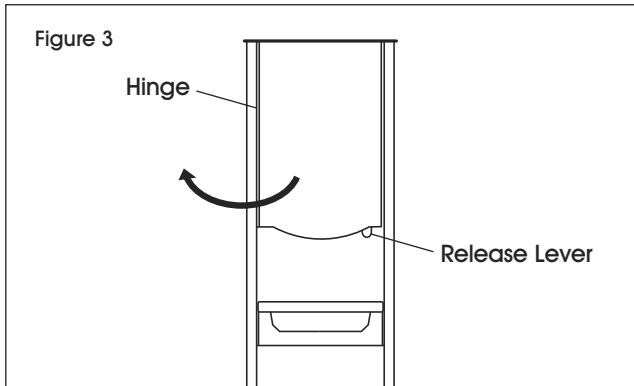

REFILL ACCESS

1. Locate the release lever to access the refill compartment. From the hinge side, pull to open. (See Figures 3-4)

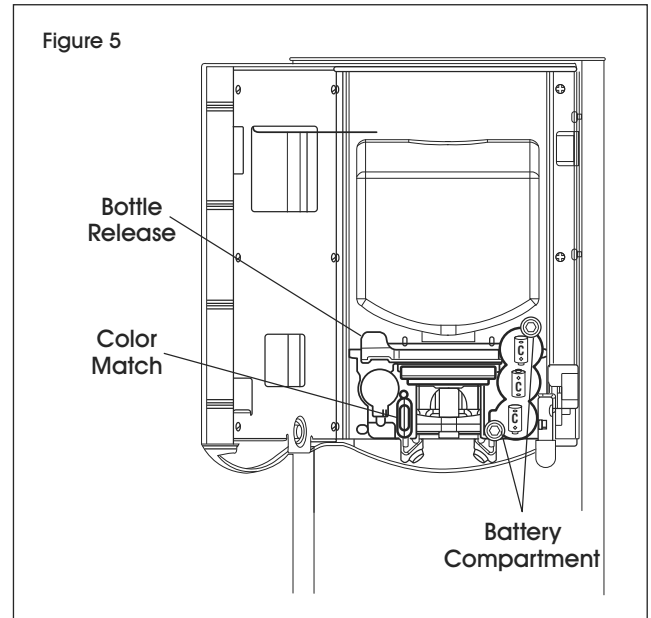

2. Check that the color of the refill matches the color key located directly below the status light. (See Figure 5)



 **NOTE: Refill not included. Customers in US and Mexico: reorder S-13808 Purell® Foam or S-19716 Purell® Gel refill cartridges. Customers in Canada: reorder S-13811 Purell® Foam or S-19717 Purell® Gel refill cartridges.**

ULINE

1-800-295-5510
uline.com

ULINE H-4786
PURELL® ELITE TFX™
DESPACHADOR DE PEDESTAL

800-295-5510
 uline.mx

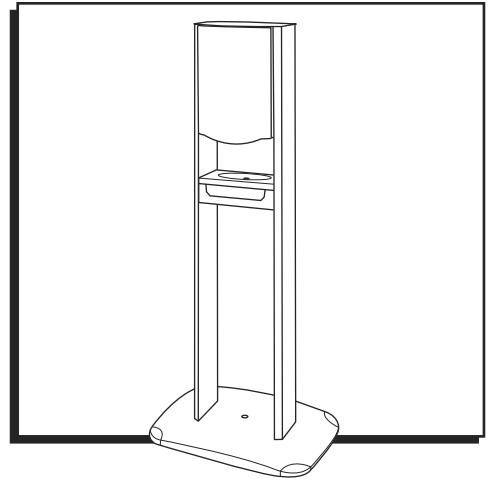

HERRAMIENTA NECESARIA



Llave Allen
 (incluida)

PARTES

Diagrama 1

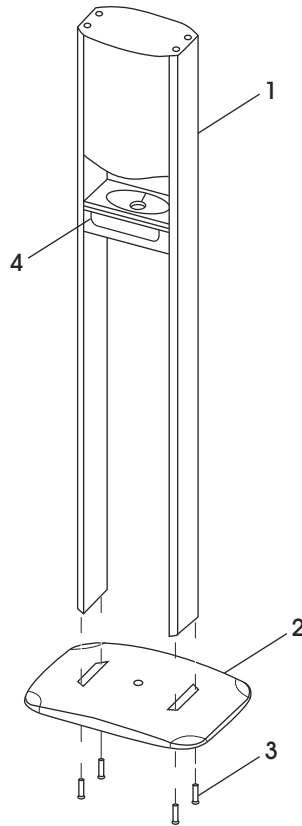

#	DESCRIPCIÓN	CANT.
1	Pedestal	1
2	Base	1
3	Tornillo	4
4	Gaveta	2

ENSAMBLE

1. Fije el pedestal a la base usando los tornillos y la llave Allen que se suministran. (Vea Diagrama 1)



NOTA: La bomba permanece activa cuando la puerta se abre. Se suministra una gaveta de repuesto. (Vea Diagrama 2)

Diagrama 2

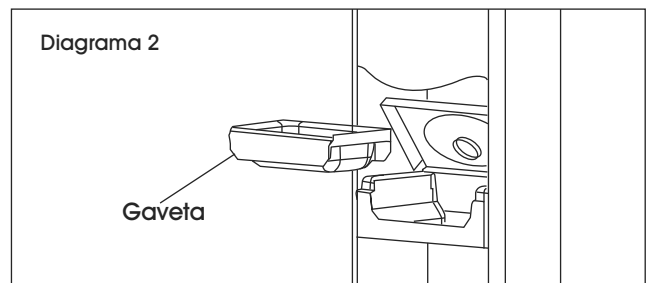

ACCESO PARA REPUESTO

1. Localice la palanca de liberación para acceder al compartimento de repuesto. Estire desde el lado de la bisagra para abrir. (Vea Diagramas 3 y 4)

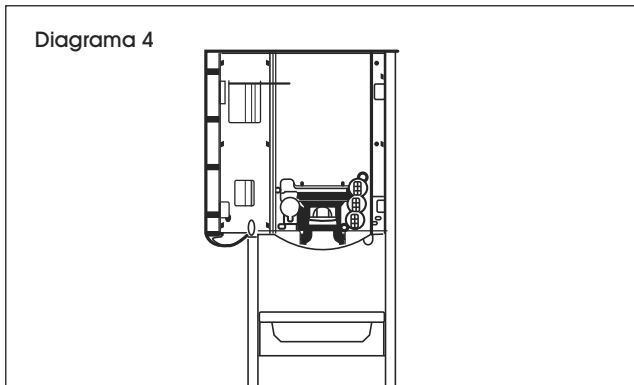
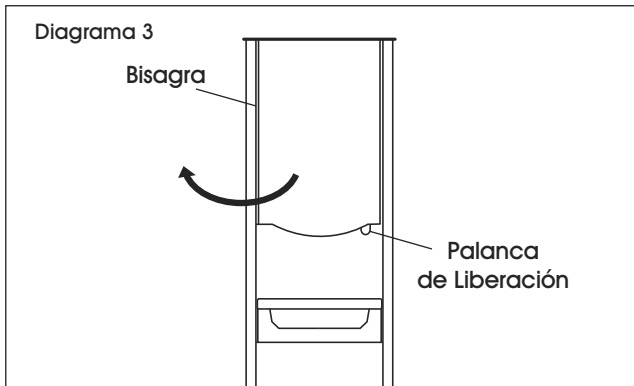

2. Compruebe que el color del repuesto sea el mismo que el de la llave de color ubicada inmediatamente debajo de la luz de estado. (Vea Diagrama 5)

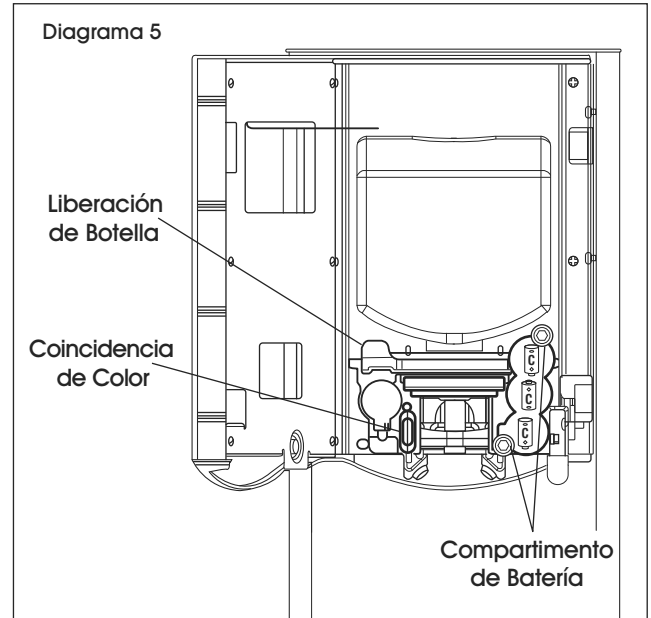

NOTA: Repuesto no incluido. Clientes en Estados Unidos de América y México: soliciten Espuma Purell® S-1388, o cartuchos de repuesto de Gel Purell® S-19716. Clientes en Canadá: soliciten Espuma Purell® S-13811 o cartuchos de repuesto de Gel Purell® S-19717.

ULINE

800-295-5510
uline.mx

ULINE H-4786

1 800 295-5510

uline.ca

**PURELL^{MD} ELITE TFX^{MC} –
SUPPORT POUR DISTRIBUTEUR**

OUTIL REQUIS



Clé Allen
(comprise)

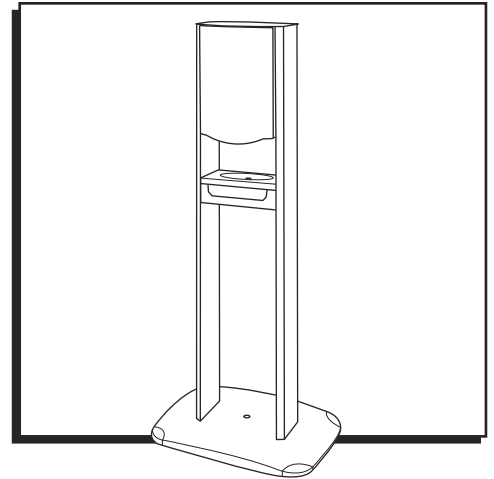

PIÈCES

Figure 1

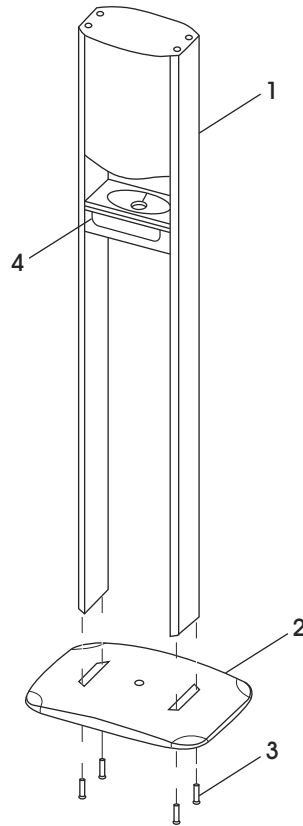

#	DESCRIPTION	QTÉ
1	Support	1
2	Base	1
3	Vis	4
4	Bac	2

ASSEMBLAGE

1. Fixez le support à la base à l'aide des vis et de la clé Allen fournies. (Voir Figure 1)



REMARQUE : La pompe reste active lorsque la porte est ouverte. Un bac de recharge est fourni. (Voir Figure 2)

Figure 2

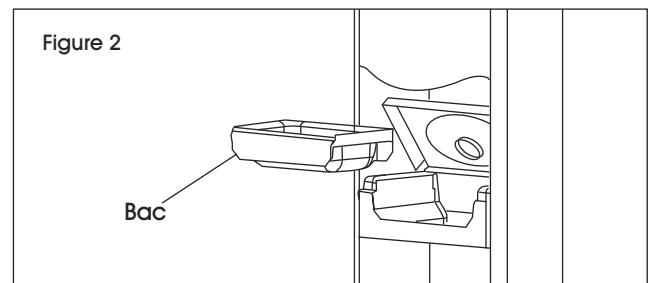

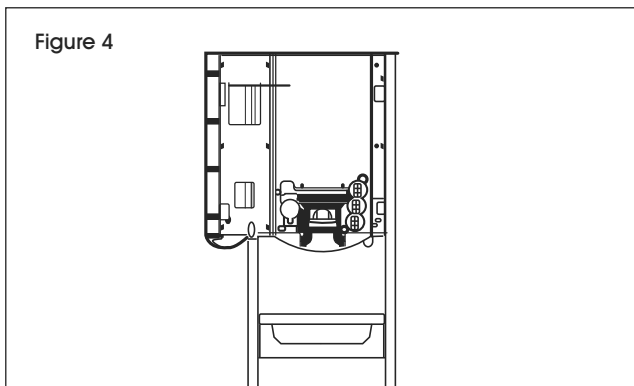
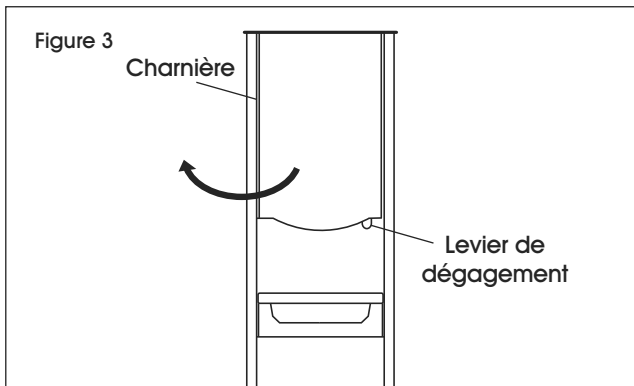

ACCÈS À LA RECHARGE

1. Repérez le levier de dégagement pour accéder au compartiment de recharge. Du côté de la charnière, tirez pour ouvrir. (Voir Figures 3 et 4)

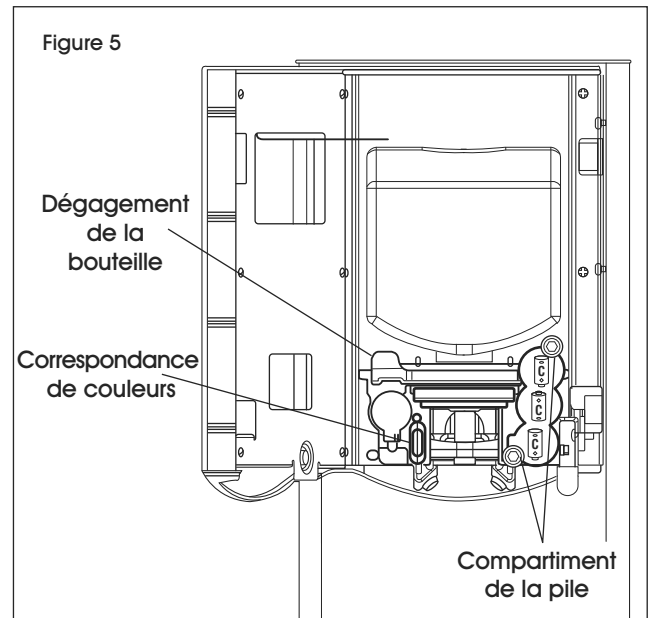

2. Vérifiez si la couleur de la recharge correspond à l'indicateur de couleur situé immédiatement sous le voyant d'état. (Voir Figure 5)



 **REMARQUE : Recharge non comprise. Clients aux États-Unis et au Mexique : commander les cartouches de recharge en mousse Purell^{MD} S-13808 ou en gel Purell^{MD} S-19716. Clients au Canada : commander les cartouches de recharge en mousse Purell^{MD} S-13811 ou en gel Purell^{MD} S-19717.**

ULINE

1 800 295-5510
uline.ca