

ULINE H-4819, H-4820

HEAVY DUTY STEEL DOLLY

1-800-295-5510
uline.com

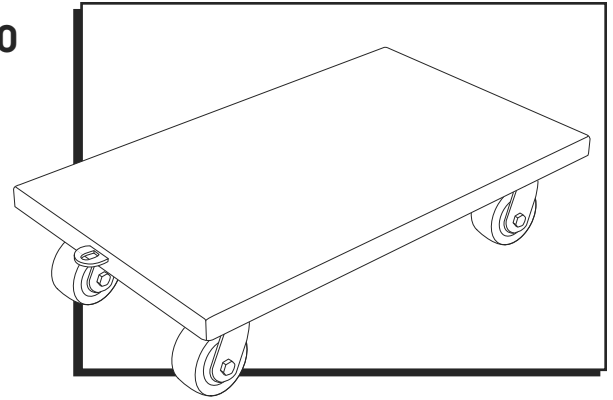

TOOL NEEDED

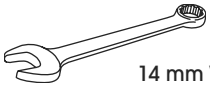

14 mm Wrench

PARTS

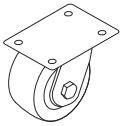

Swivel Caster x 4

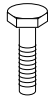

Bolt x 16



Lock Washer x 16



Washer x 16

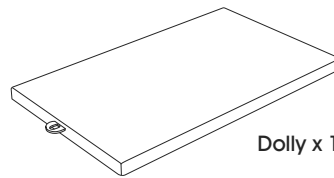

Dolly x 1

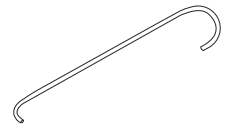

Tow Rod x 1

ASSEMBLY

1. Align caster plate with bolt holes on underside of dolly.
2. Slide a lock washer onto each bolt. Slide a washer onto each bolt.
3. Insert four bolts through caster plate into dolly.
4. Tighten bolts with a 14 mm wrench.
5. Repeat for remaining casters.

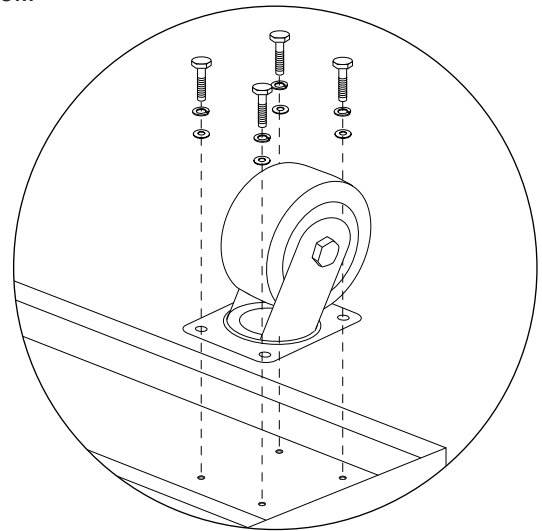
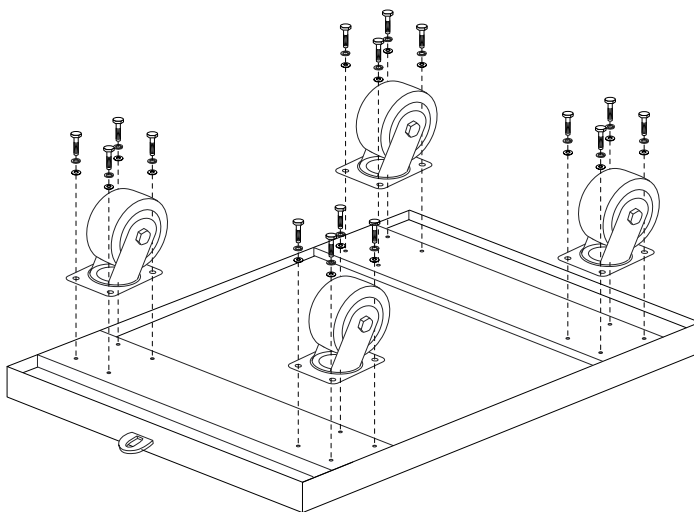

ULINE H-4819, H-4820

PLATAFORMA DE ACERO PARA USO PESADO CON RUEDAS

800-295-5510
uline.mx

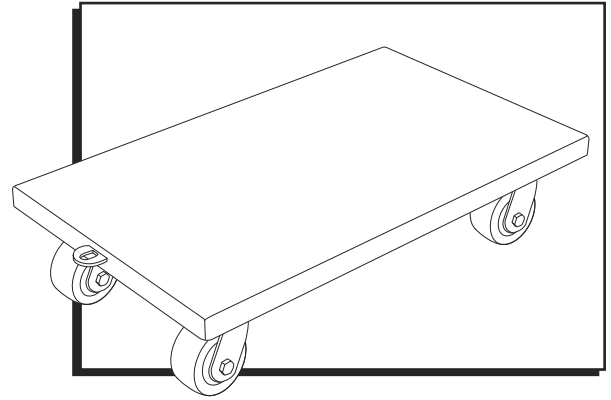

HERRAMIENTA NECESARIA

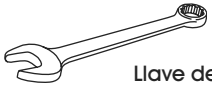

Llave de 14 mm

PARTES

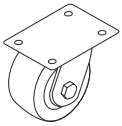

4 Ruedas Giratorias

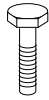

16 Pernos



16 Rondanas
de Seguridad



16 Rondanas

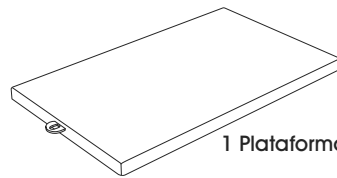

1 Plataforma

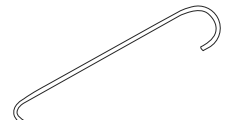

1 Varilla de Arrastre

ENSAMBLE

1. Alinee la placa de las ruedas con los orificios para los pernos de la parte inferior de la plataforma.
2. Deslice una rondana de seguridad en cada perno. Deslice una arandela en cada perno.
3. Inserte cuatro pernos a través de la placa de las ruedas en la plataforma.
4. Apriete los pernos con una llave de 14 mm.
5. Repita con las ruedas restantes.

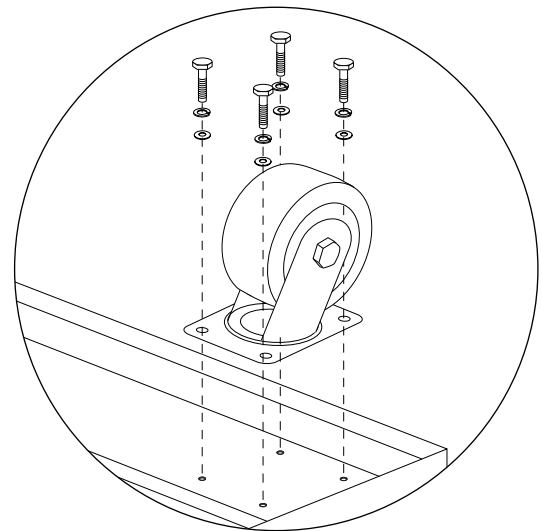
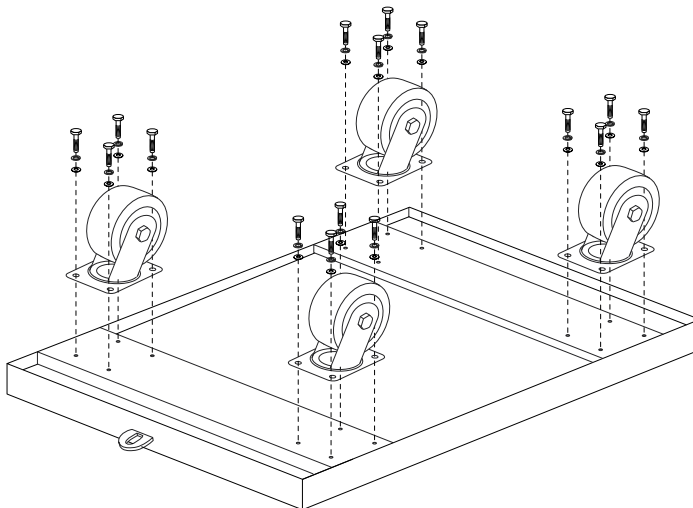

ULINE H-4819, H-4820

SOCLE ROULANT EN ACIER ROBUSTE

1-800-295-5510

uline.ca

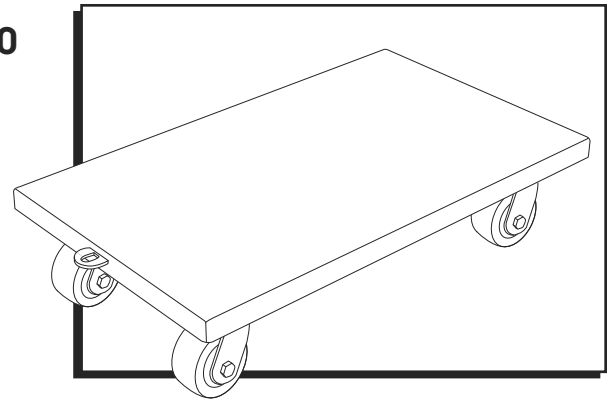

OUTIL REQUIS



Clé de 14 mm

PIÈCES

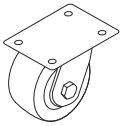

Roulette pivotante x 4

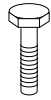

Boulon x 16



Rondelle de blocage x 16



Rondelle x 16

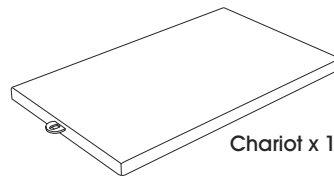

Chariot x 1

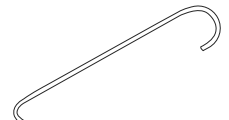

Tige de remorque x 1

ASSEMBLAGE

1. Alignez une plaque de roulette avec les trous à boulon situés en dessous du chariot.
2. Enfilez une rondelle de blocage à chaque boulon. Glissez une rondelle sur chaque boulon.
3. Insérez quatre boulons dans les trous du chariot en les enfilant à travers la plaque de roulette.
4. Serrez les boulons avec une clé de 14 mm.
5. Répétez cette procédure pour les autres roulettes pivotantes.

