

ULINE H-4884

ALUMINUM STANDARD HAND TRUCK

LOOP HANDLE WITH SOLID RUBBER WHEELS

1-800-295-5510
uline.com

TOOLS NEEDED



6 mm Allen Wrench



13 mm Wrench

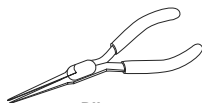

Pliers

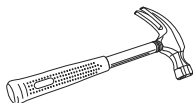

Hammer

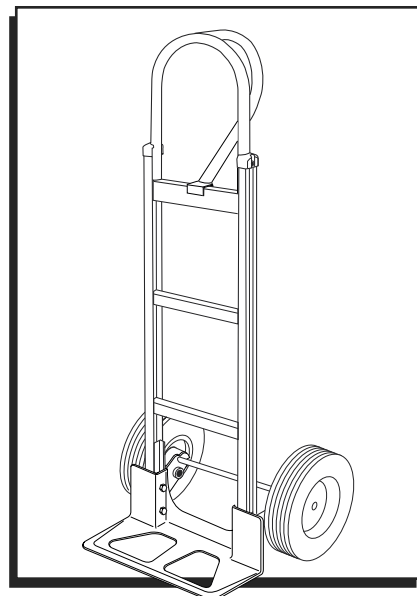

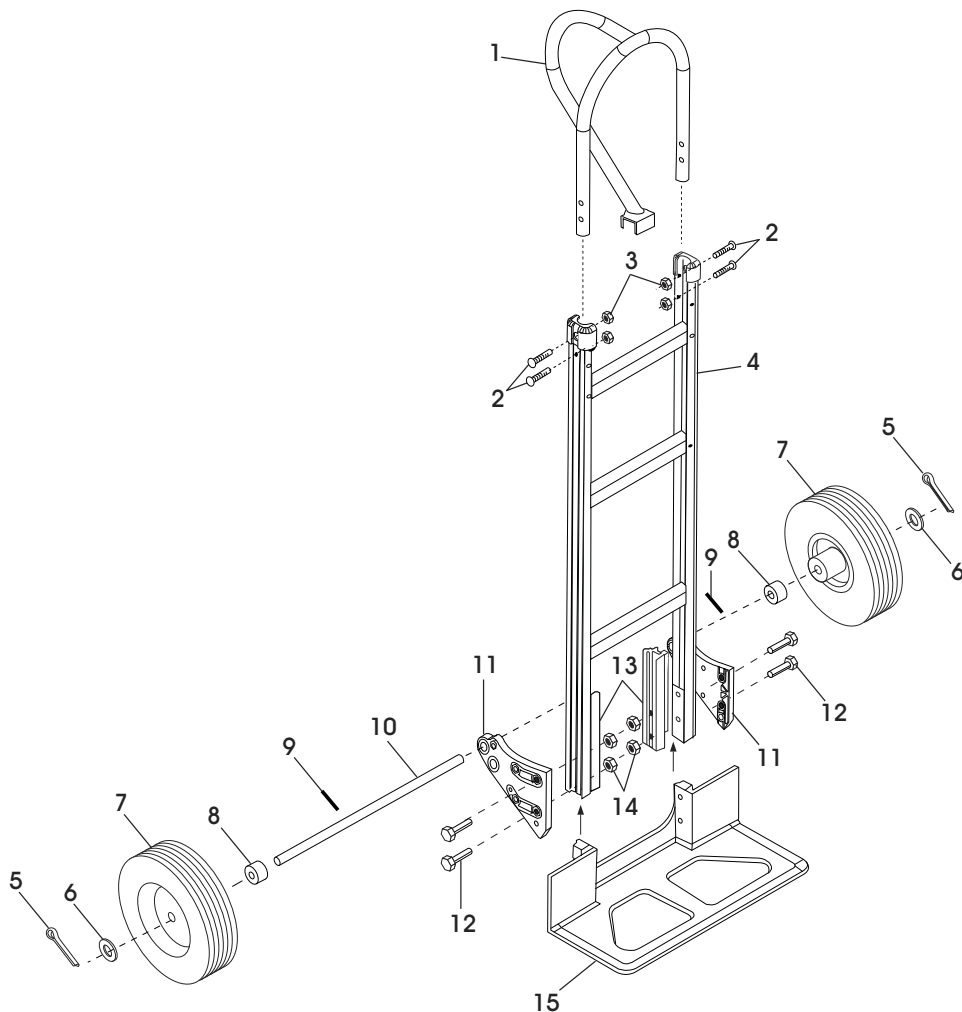

PARTS

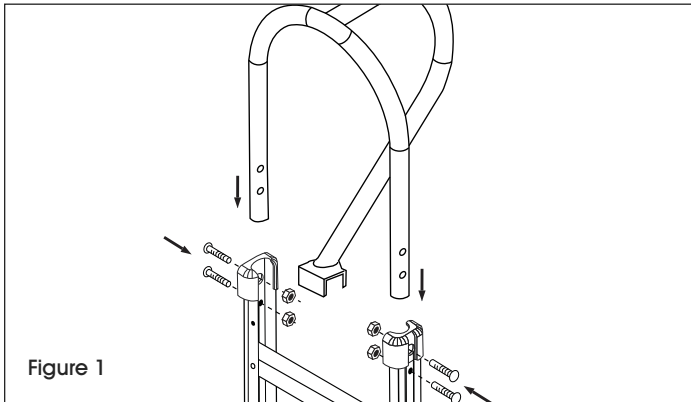

#	DESCRIPTION	QTY.
1	Handle	1
2	6 mm Bolt	4
3	6 mm Locknut	4
4	Frame	1
5	Cotter Pin	2
6	Washer	2
7	Wheel	2
8	Spacer	2
9	Round Pin	2
10	Axle	1
11	Axle Support	2
12	8 mm Bolt	4
13	Frame Reinforcement	2
14	8 mm Locknut	4
15	Nose Plate	1

ASSEMBLY



 **NOTE:** Do not use air or power tools.

ATTACH HANDLE

1. Slide handle into the top rails of frame. Align holes in handle and frame. Insert four 6mm bolts through the frame and handle and secure with locknuts. (See Figure 1)

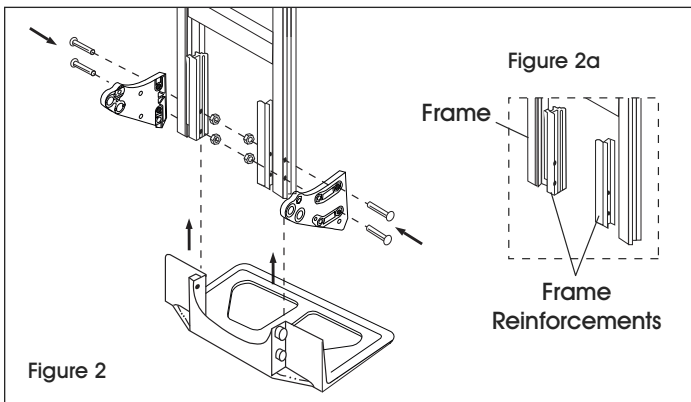

ATTACH NOSE PLATE AND AXLE SUPPORTS

1. Position frame reinforcements against bottom frame rail. (See Figure 2a) Slide nose plate into channel on frame reinforcement, keeping bolt holes aligned. (See Figure 2)
2. Align axle support with outside rail of frame. (See Figure 2)
3. Insert four 8 mm bolts through the axle supports, frame, frame reinforcements and nose plate. Secure with locknuts but DO NOT tighten. (See Figure 2)

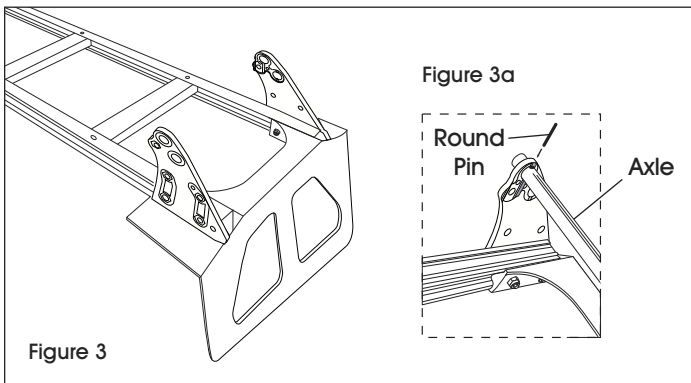

ATTACH AXLE AND WHEELS

1. Lay hand truck on front so axle supports face upwards. (See Figure 3)

 **WARNING!** If installing stair climber, refer to instructions included with stair climber and skip step 2. Once complete, continue with step 3. If not installing stair climber, continue to step 2.

2. Insert axle through holes in axle supports. Align holes in axle with grooves on inside of the axle supports. Use a hammer to tap in the round pins. (See Figure 3a)
3. Slide a spacer onto each end of the axle. Slide a wheel onto each end of the axle. Slide a washer onto each end of the axle. (See Figure 4)
4. Insert a cotter pin through the holes in each end of the axle. Bend cotter pins using pliers to secure wheels. Wheels should spin freely. (See Figure 4)
5. Tighten all locknuts.

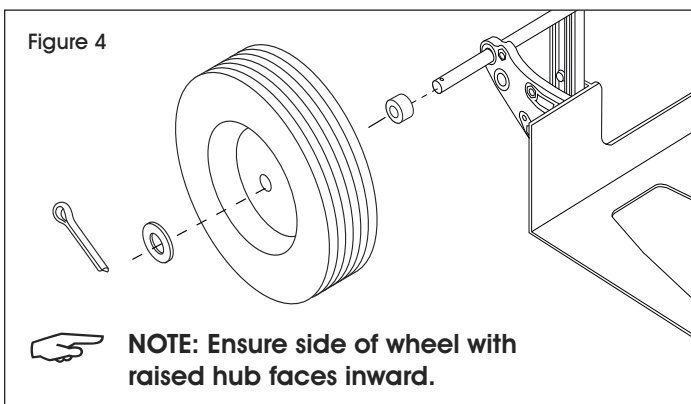

ULINE

1-800-295-5510

uline.com

ULINE H-4884

DIABLITO DE ALUMINIO

ESTÁNDAR

ASA CURVADA Y LLANTAS
SÓLIDAS DE CAUCHO

800-295-5510

uline.mx

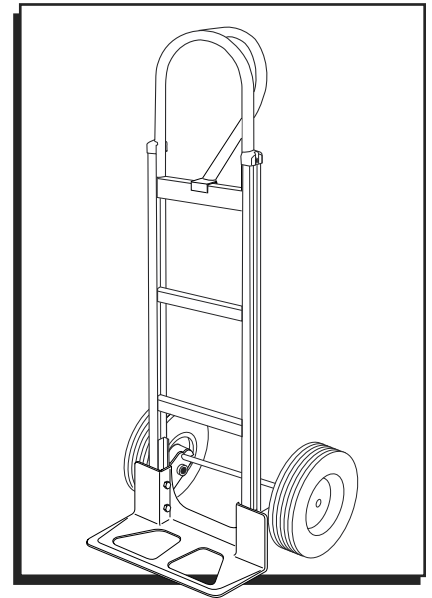

HERRAMIENTAS NECESARIAS



Llave Allen de 6 mm



Llave de 13 mm

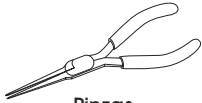

Pinzas

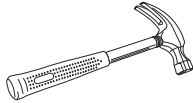

Martillo

PARTES

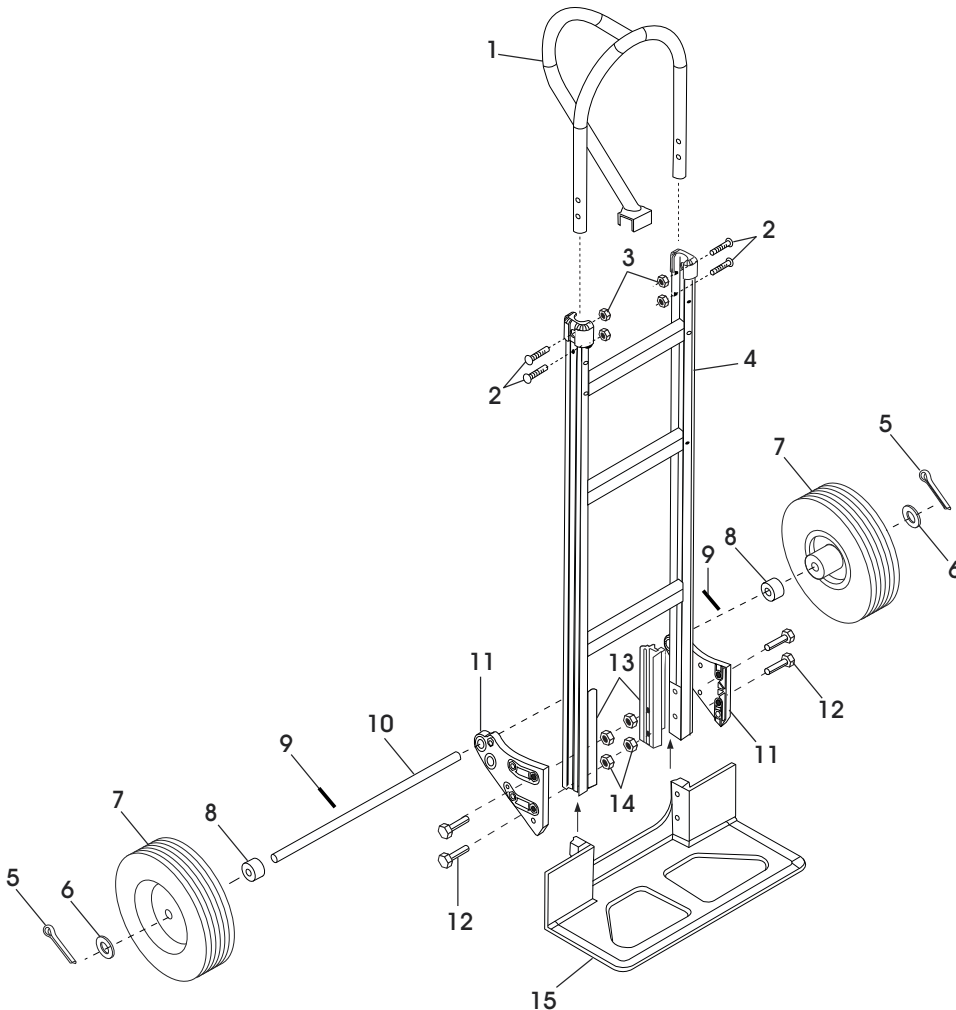

#	DESCRIPCIÓN	CANT.
1	Asa	1
2	Perno de 6 mm	4
3	Tuerca de seguridad de 6 mm	4
4	Armazón	1
5	Pasador de Chaveta	2
6	Arandela	2
7	Llanta	2
8	Separador	2
9	Pasador Redondo	2
10	Eje	1
11	Soporte del Eje	2
12	Perno de 8 mm	4
13	Refuerzo del Armazón	2
14	Tuerca de seguridad de 8 mm	4
15	Placa Delantera	1

ENSAMBLE

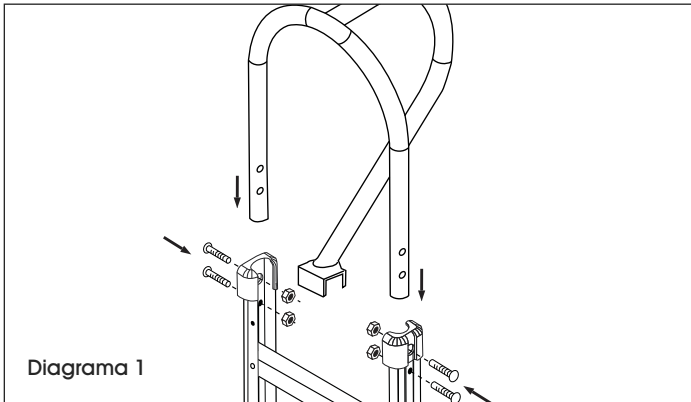

NOTA: No use herramientas eléctricas ni neumáticas.

FIJE EL ASA

1. Deslice el asa hacia los rieles superiores del armazón. Alinee los orificios en el asa y el armazón. Inserte cuatro pernos de 6 mm a través del armazón y el asa y fíjelos con tuercas de seguridad. (Vea Diagrama 1)

FIJE LA PLACA DELANTERA Y LOS SOPORTES DEL EJE

1. Coloque los refuerzos del armazón contra el fondo del riel del armazón. (Vea Diagrama 2a) Deslice la placa delantera hacia el canal en los refuerzos del armazón, manteniendo alineados los orificios de los pernos. (Vea Diagrama 2)
2. Alinee el soporte del eje con el riel exterior del armazón. (Vea Diagrama 2)
3. Inserte cuatro pernos de 8 mm a través de los soportes del eje, el armazón, los refuerzos del armazón y la placa delantera. Asegure con tuercas de seguridad pero NO apriete. (Vea Diagrama 2)

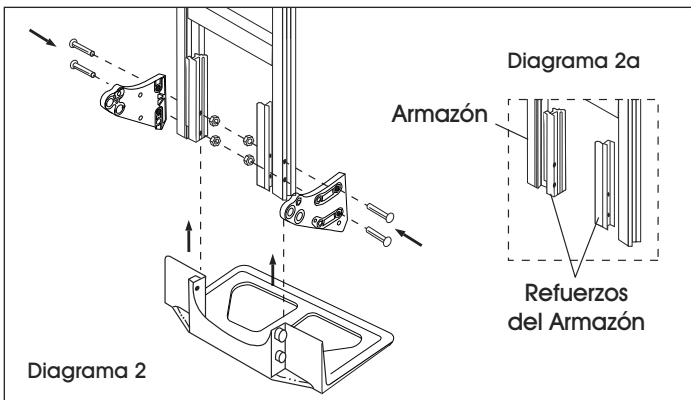

FIJE EL EJE Y LAS LLANTAS

1. Apoye el diablito sobre su parte delantera de forma que los soportes del eje apunten hacia arriba. (Vea Diagrama 3)

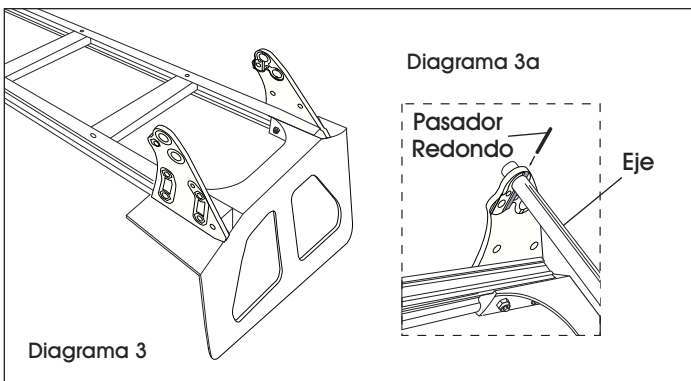

¡ADVERTENCIA! Si va a colocar el aditamento para escaleras, siga las instrucciones que incluye el aditamento y omita el paso 2. Una vez que termine de instalar, continúe con el paso 3. Si no va a colocar el aditamento para escaleras, continúe con el paso 2.

2. Inserte el eje a través de los orificios en los soportes del eje. Alinee los orificios del eje con las muescas de la parte interior de los soportes del eje. Use un martillo para introducir los pasadores redondos. (Vea Diagrama 3a)
3. Deslice un separador en cada extremo del eje. Deslice una llanta en cada extremo del eje. Deslice una arandela en cada extremo del eje. (Vea Diagrama 4)
4. Inserte un pasador de chaveta a través de los orificios en cada extremo del eje. Doble los pasadores de chaveta usando unas pinzas para asegurar las llantas. Las llantas deben girar libremente. (Vea Diagrama 4)
5. Apriete todas las tuercas de seguridad.

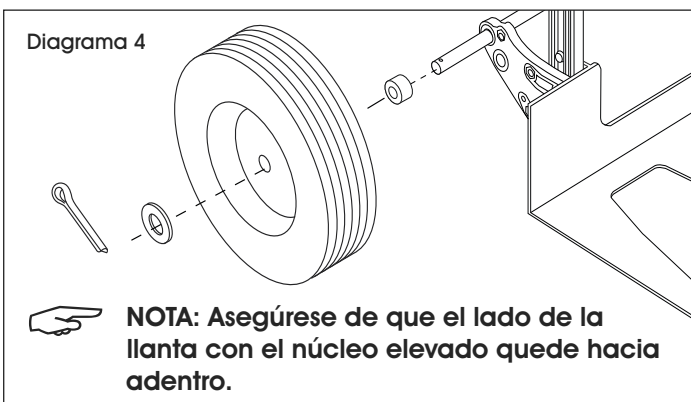

ULINE

800-295-5510
uline.mx

ULINE H-4884

**DIABLE DE MANUTENTION
STANDARD EN ALUMINIUM**
POIGNÉE EN ANSE AVEC ROUES EN
CAOUTCHOUC PLEIN

1 800 295-5510
uline.ca

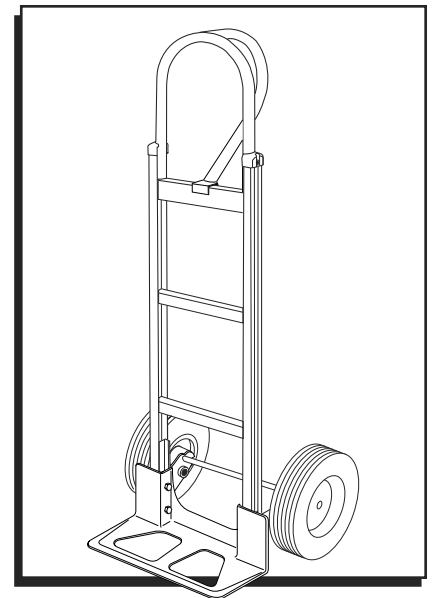

OUTILS REQUIS



Clé Allen de 6 mm

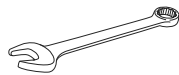

Clé de 13 mm

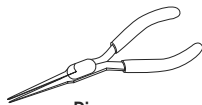

Pinces

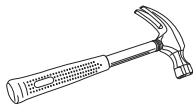

Marteau

PIÈCES

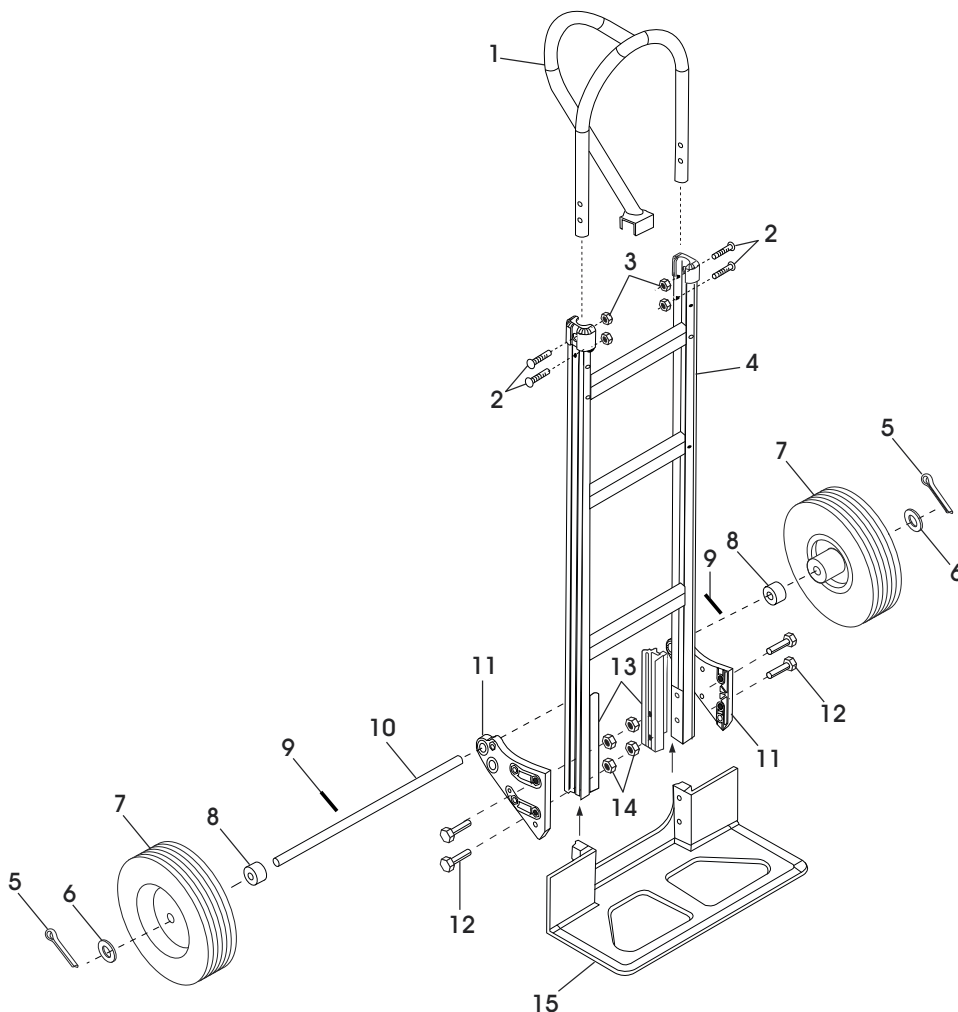

#	DESCRIPTION	QTÉ
1	Poignée	1
2	Boulon de 6 mm	4
3	Écrou freiné de 6 mm	4
4	Cadre	1
5	Goupille fendue	2
6	Rondelle	2
7	Roue	2
8	Entretoise	2
9	Goupille	2
10	Essieu	1
11	Support d'essieu	2
12	Boulon de 8 mm	4
13	Renfort de cadre	2
14	Écrou freiné de 8 mm	4
15	Bavette	1

MONTAGE

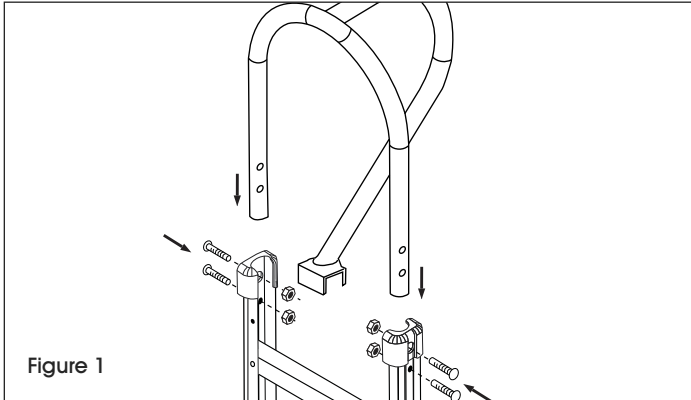

 **REMARQUE :** N'utilisez pas d'outils pneumatiques ou électriques.

FIXATION DE LA POIGNÉE

1. Insérez la poignée dans les glissières à l'extrémité supérieure du cadre. Alignez les trous de la poignée et du cadre. Insérez quatre boulons de 6 mm à travers le cadre et la poignée et fixez-les à l'aide des écrous freinés. (Voir Figure 1)

FIXATION DE LA BAVETTE ET DES SUPPORTS D'ESSIEU

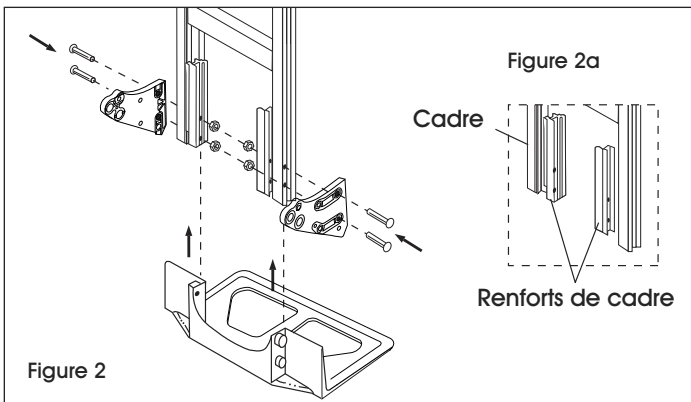

1. Positionnez les renforts de cadre contre les glissières à l'extrémité inférieure du cadre. (Voir Figure 2a) Glissez la bavette dans la cannelure des renforts de cadre en gardant les trous de boulon alignés. (Voir Figure 2)
2. Alignez chaque support d'essieu avec la glissière extérieure du cadre. (Voir Figure 2)
3. Insérez quatre boulons de 8 mm à travers les supports d'essieu, le cadre, les renforts de cadre et la bavette. Fixez avec les écrous freinés, mais NE serrez PAS. (Voir Figure 2)

FIXATION DE L'ESSIEU ET DES ROUES

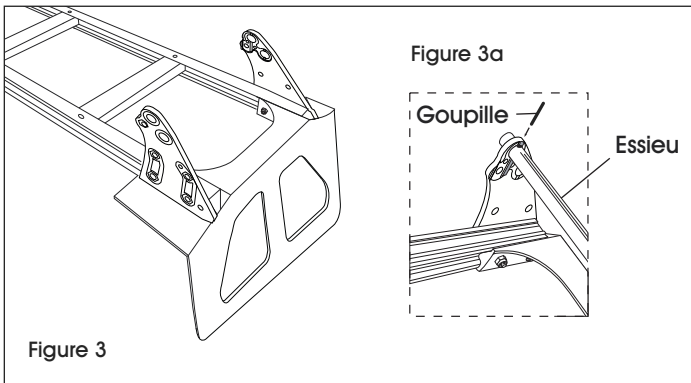

1. Posez le diable vers l'avant de sorte que les supports d'essieu soient orientés vers le haut. (Voir Figure 3)

 **AVERTISSEMENT!** Si vous voulez installer un escaladeur, référez-vous aux instructions fournies avec l'accessoire et ignorez l'étape 2. Une fois complété, continuez avec l'étape 3. Si vous n'installez pas d'escaladeur, continuez avec l'étape 2.

2. Enfilez l'essieu dans les trous des supports d'essieu. Alignez les trous dans l'essieu avec les rainures à l'intérieur des supports d'essieu. Utilisez un marteau pour planter les goupilles. (Voir Figure 3a)
3. Enfilez une entretoise à chaque extrémité de l'essieu. Enfilez une roue à chaque extrémité de l'essieu. Enfilez une rondelle à chaque extrémité de l'essieu. (Voir Figure 4)
4. Insérez une goupille fendue dans le trou à chaque extrémité de l'essieu. Repliez les goupilles à l'aide de pinces afin de fixer les roues en place. Les roues doivent tourner librement. (Voir Figure 4)
5. Serrez tous les écrous freinés.

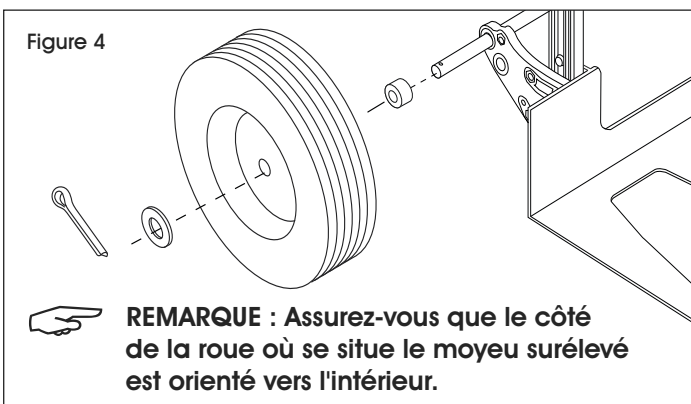

ULINE

1 800 295-5510

uline.ca