

**ULINE** H-5098, H-5099, H-5872  
H-5873, H-7081

1-800-295-5510  
uline.com

# CROWD CONTROL WITH RETRACTABLE BELT

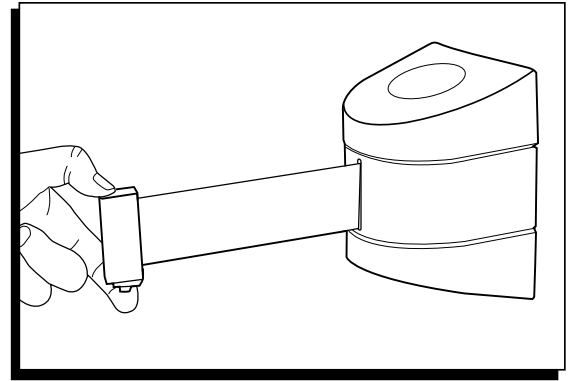

## TOOLS NEEDED

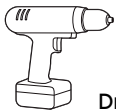

Drill



17/64"  
Drill Bit

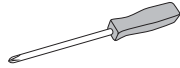

Phillips  
Screwdriver

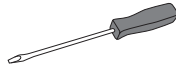

Flathead  
Screwdriver



Hammer  
(optional)

## PARTS

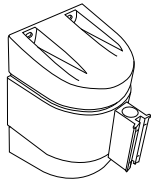

Wall-Mounted Unit x 1

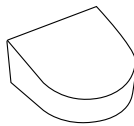

Cap x 2

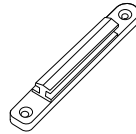

Wall Receiver x 1

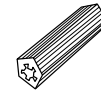

Wall Anchor x 6



Screw x 6

## INSTALLATION



**NOTE:** Caps will need to be removed prior to installation. See Cap Fitting and Removal on page 3.

### WALL MOUNT INSTALLATION

1. Place the wall-mounted unit in the location required and use a pencil to mark the position of the four screw holes. (See Figure 1)

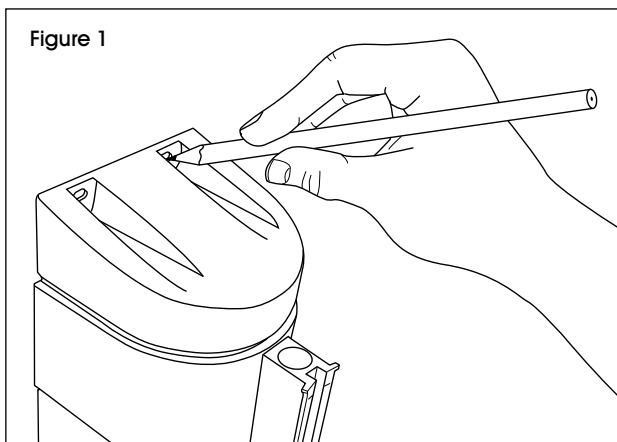

**WARNING!** Before drilling into a wall, always ensure the area is clear of any electrical wiring or plumbing pipes.

2. Using a 17/64" drill bit, drill four holes in the positions marked. (See Figure 2)

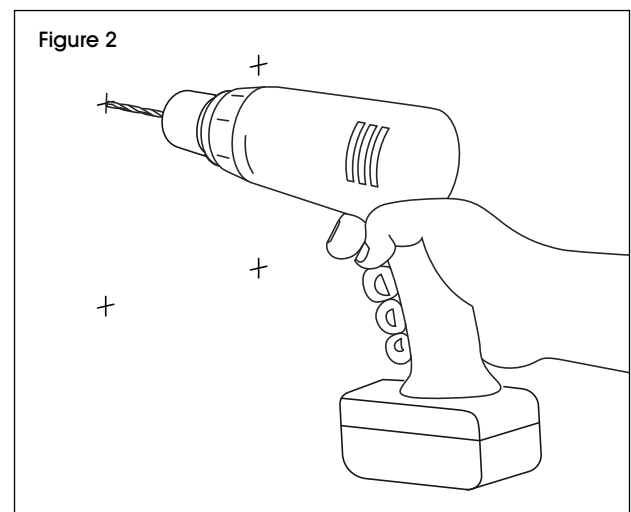

# INSTALLATION CONTINUED

3. Insert a wall anchor (included) in each hole, ensuring the plug is flush with the wall surface. (See Figure 3)

 **NOTE:** This step may require a light tap with hammer.

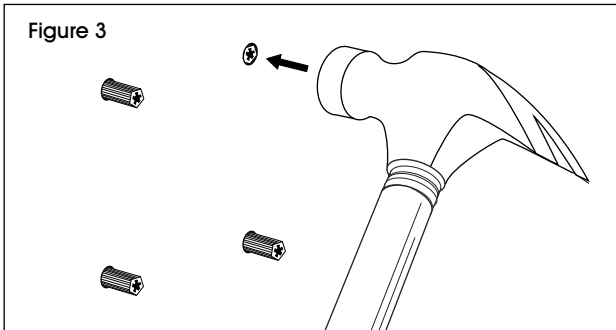

4. Place the wall-mounted unit over the screw holes and screw unit to wall using the screws supplied. (See Figure 4)

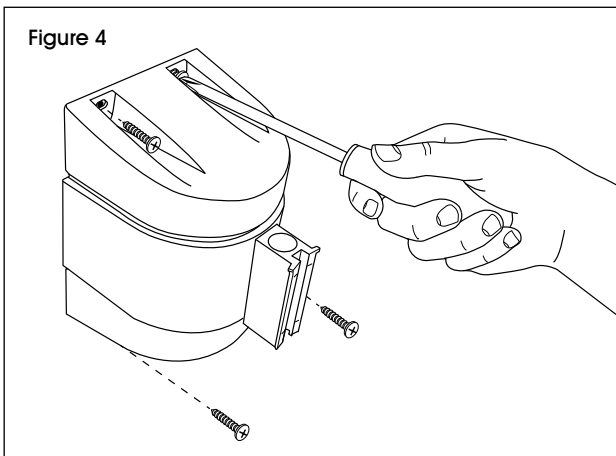

5. Attach the top and bottom caps to the wall-mounted unit. (See Figure 5)

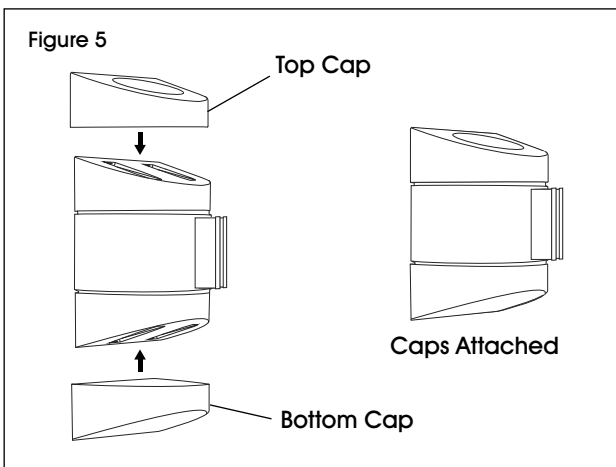

6. Clip the wall receiver to the belt end and extend the belt to the opposite wall. (See Figure 6)

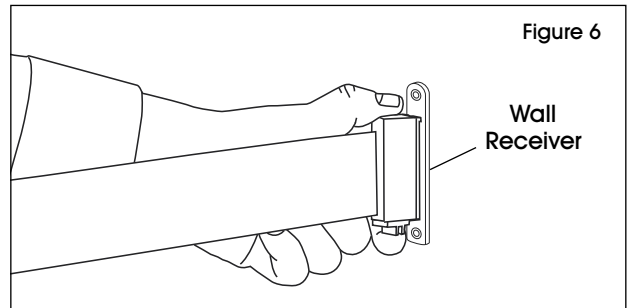

7. Use a pencil to mark the required location for wall receiver's screw holes. (See Figure 7)

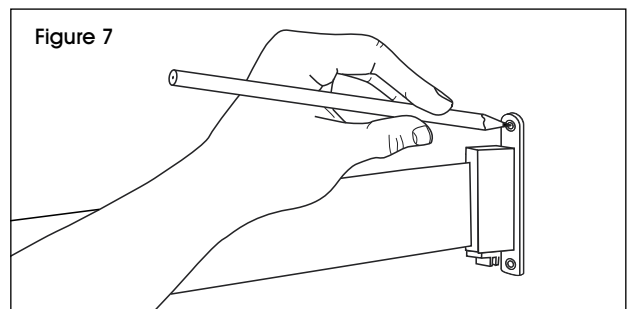

8. Using a 1/16" drill bit, drill two holes in the positions marked. (See Figure 8)

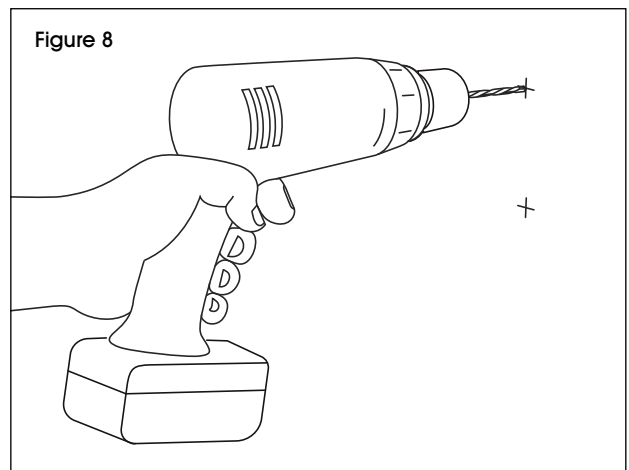

## INSTALLATION CONTINUED

9. Insert a wall anchor in each hole, ensuring the anchor is flush with the wall surface. (See Figure 9)

 **NOTE:** This step may require a light tap with hammer.

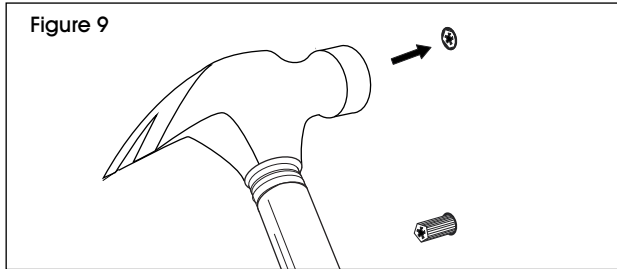

10. Place wall receiver over screw holes and attach using supplied screws. (See Figure 10)

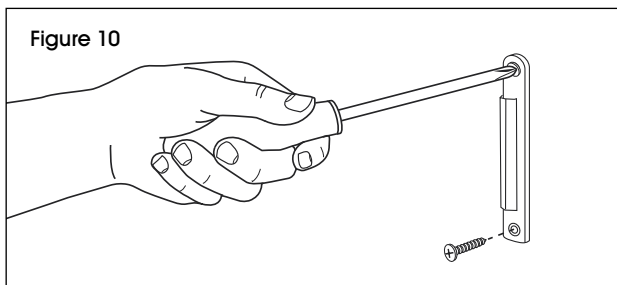

## CAP FITTING AND REMOVAL

### FITTING

1. Slide the cap on using a downward motion. (See Figure 11)

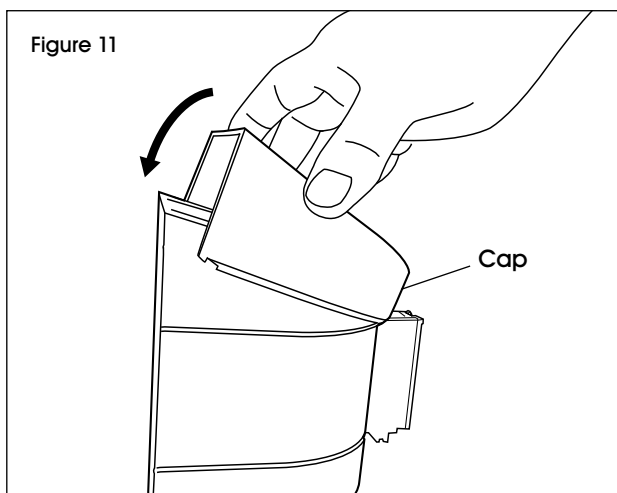

2. Snap the locking tabs in place. If necessary, press in from the sides to locate the tabs. (See Figure 12)

 **NOTE:** Press in from the side to correctly seat locking tab.

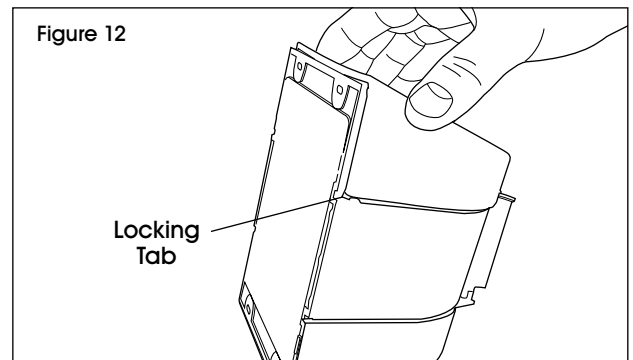

### REMOVAL

1. Insert flathead screwdriver or other implement between the cap and housing. Twist to release the locking tabs from the catch on each side. (See Figure 13)

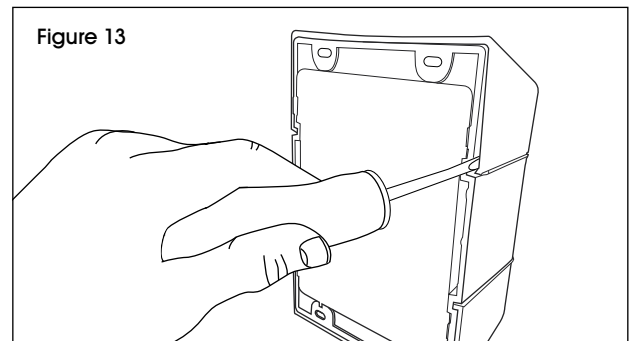

2. Slide the cap away from wall to remove. (See Figure 14)

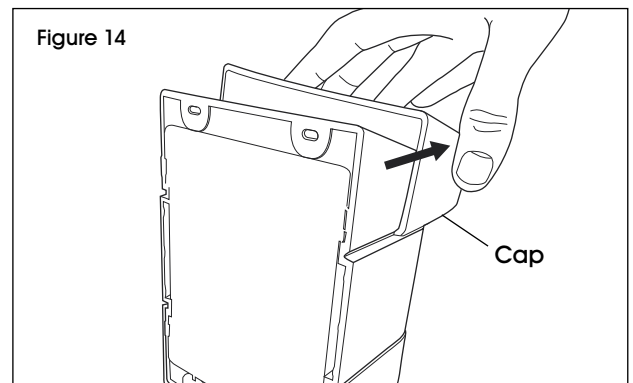

**ULINE**

1-800-295-5510  
uline.com



H-5098, H-5099, H-5872  
H-5873, H-7081

# CONTROL DE MULTITUDES CON CINTA RETRÁCTIL

800-295-5510  
uline.mx

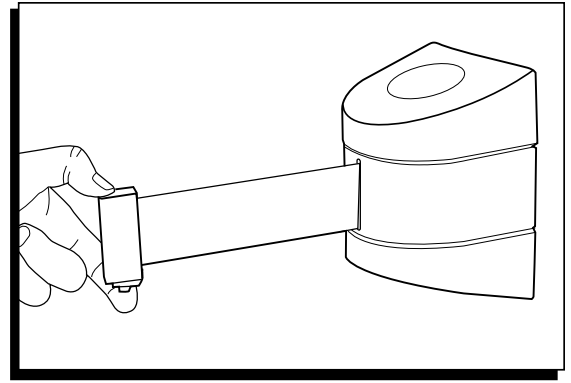

## HERRAMIENTAS NECESARIAS



Taladro



Broca de  
17/64"

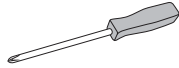

Desarmador  
de Cruz

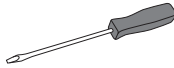

Desarmador  
Plano



Martillo  
(opcional)

## PARTES

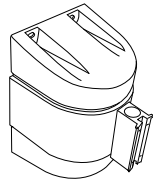

1 Unidad para  
Instalación en Pared

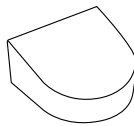

2 Tapas

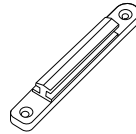

1 Receptor para  
Instalación en Pared

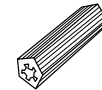

6 Taquetes



6 Tornillos

## INSTALACIÓN



**NOTA:** Necesita quitar las tapas antes de instalarlo. Vea Colocación y Remoción de las Tapas en la página 6.

### INSTALACIÓN EN PARED

1. Coloque la unidad para instalación en pared en la ubicación que la requiere y utilice un lápiz para marcar la posición de los cuatro orificios para los tornillos. (Vea Diagrama 1)

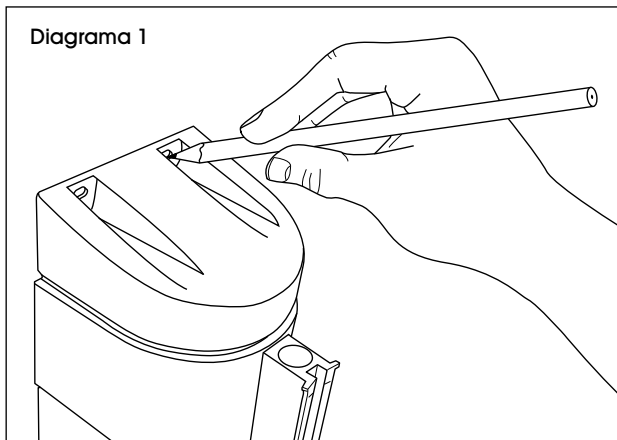

**iADVERTENCIA!** Antes de perforar una pared, asegúrese siempre de que el área esté libre de cables eléctricos o tuberías.

2. Utilice una broca de 17/64", perforo cuatro orificios en cada marca del lápiz. (Vea Diagrama 2)

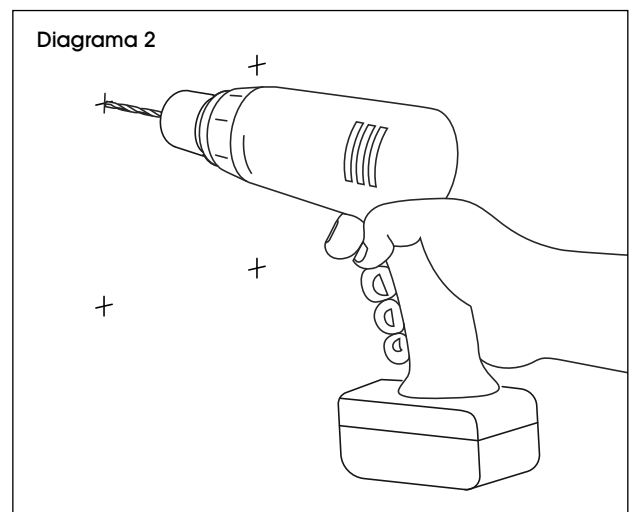

## CONTINUACIÓN DE INSTALACIÓN

3. Inserte un taquete (incluido) en cada orificio, asegúrese de que el tapón quede a ras con la superficie de la pared. (Vea Diagrama 3)

 **NOTA:** Este paso requiere un golpe ligero con un martillo.

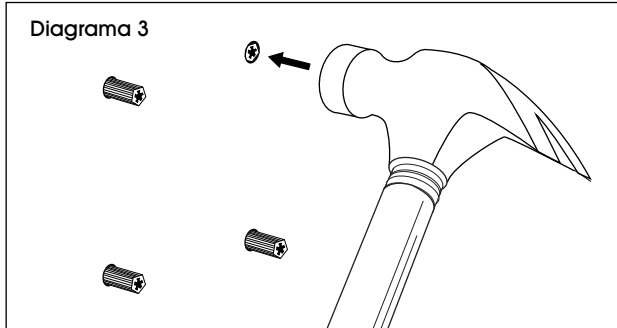

4. Coloque la unidad de pared en los orificios y atornílela utilizando los tornillos suministrados. (Vea Diagrama 4)

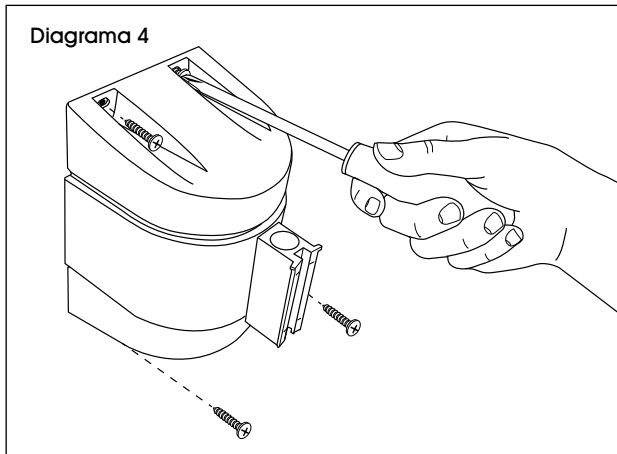

5. Fije las tapas superior e inferior a la unidad. (Vea Diagrama 5)

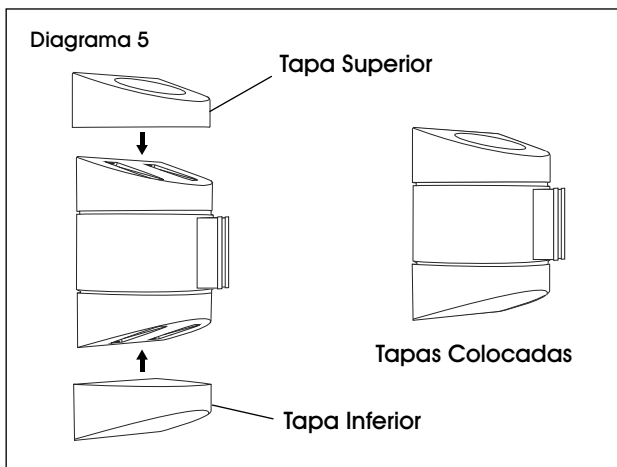

6. Sujete el receptor de pared en el extremo de la cinta y extienda hacia la pared opuesta. (Vea Diagrama 6)

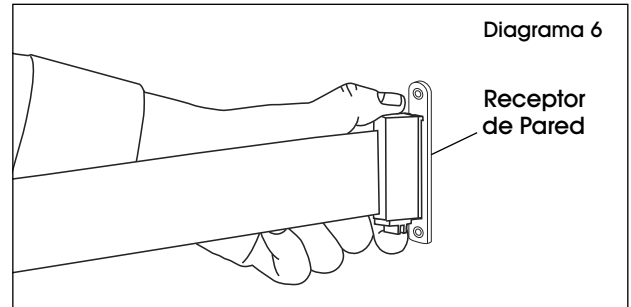

7. Utilice un lápiz para marcar en la pared la ubicación deseada de los orificios para tornillos del receptor. (Vea Diagrama 7)

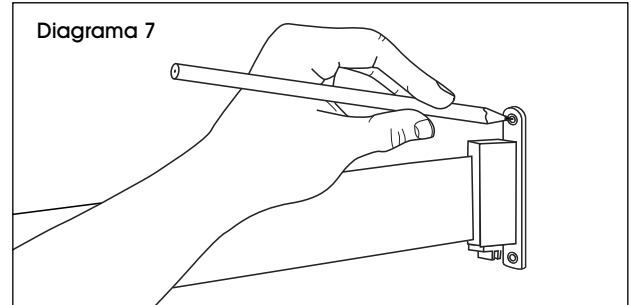

8. Utilice una broca de 17/64", perforo dos orificios en cada marca del lápiz. (Vea Diagrama 8)

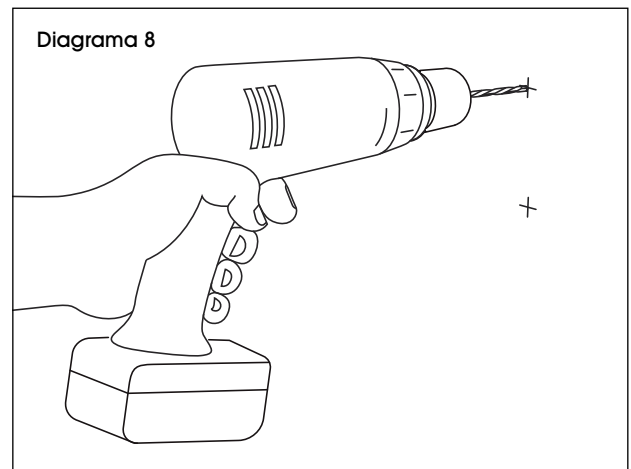

## CONTINUACIÓN DE INSTALACIÓN

9. Inserte el taquete en cada orificio, asegúrese de que el taquete quede a ras con la superficie de la pared. (Vea Diagrama 9)

 **NOTA:** Este paso requiere un golpe ligero con un martillo.

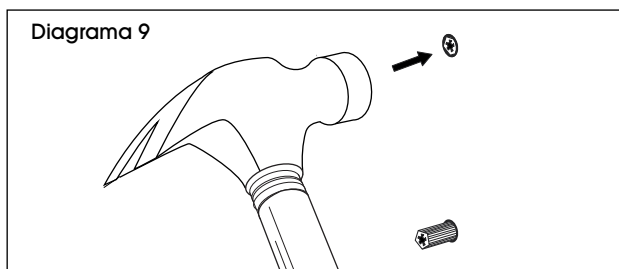

10. Coloque el receptor de pared sobre los orificios y fíjelo con los tornillos suministrados. (Vea Diagrama 10)

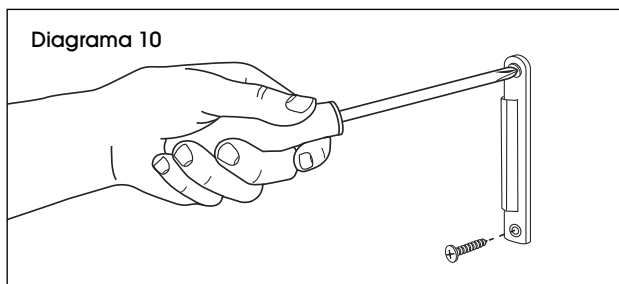

## COLOCACIÓN Y REMOCIÓN DE LAS TAPAS

### COLOCACIÓN

1. Deslice la tapa con movimiento descendente. (Vea Diagrama 11)

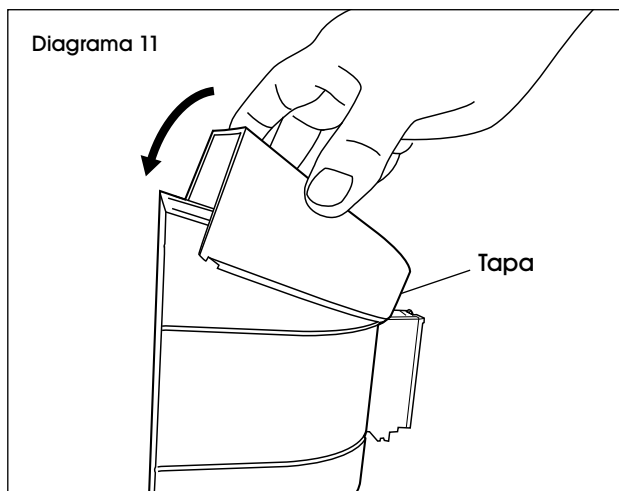

2. Presione las pestañas de bloqueo en su lugar. Si fuera necesario, presione desde los costados para ubicar las pestañas. (Vea Diagrama 12)

 **NOTA:** Presione desde el costado para colocar la pestaña de bloqueo correctamente.



### REMOCIÓN

1. Inserte el desarmador plano u otro utensilio entre la tapa y la cubierta. Gire para liberar las pestañas de bloqueo del pestillo de cada lado. (Vea Diagrama 13)

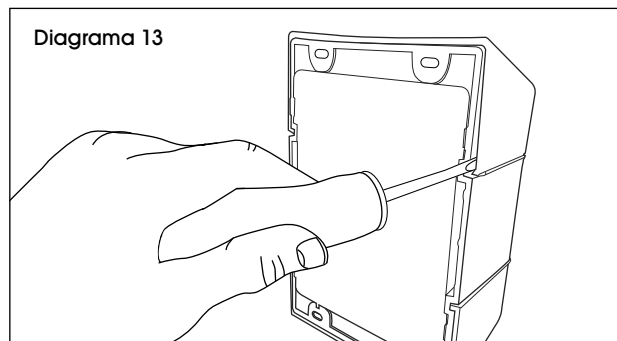

2. Deslice la tapa para quitarla alejándola de la pared. (Vea Diagrama 14)

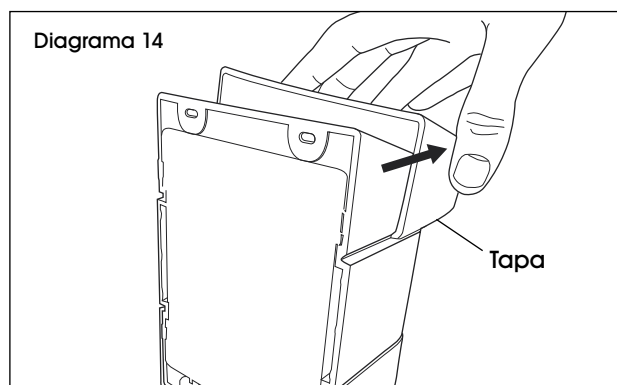

**ULINE**

800-295-5510  
uline.mx

# CANALISATION DES FOULES À SANGLE RÉTRACTABLE

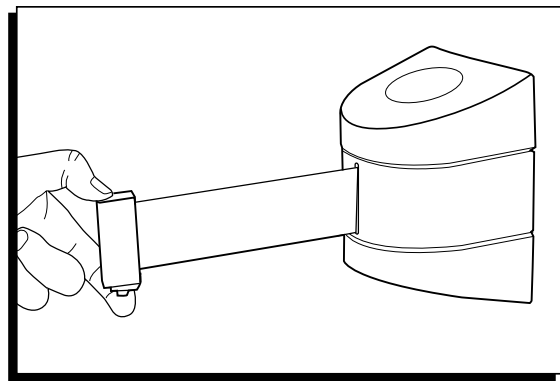

## OUTILS REQUIS



Perceuse



Mèche de perceuse  
de 17/64 po

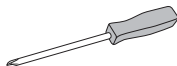

Tournevis  
cruciforme

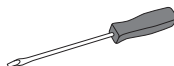

Tournevis à  
tête plate

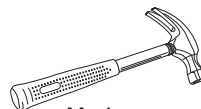

Marteau  
(optionnel)

## PIÈCES

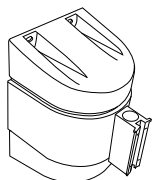

Dispositif à fixation  
murale x 1

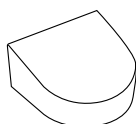

Capuchon x 2

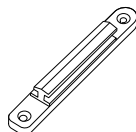

Récepteur mural x 1



Ancrage mural x 6



Vis x 6

## INSTALLATION



**REMARQUE :** Les capuchons doivent être enlevés avant de procéder à l'installation. Voir la section Installation et retrait des capuchons à la page 9.

### FIXATION MURALE

1. Placez le dispositif à fixation murale à l'emplacement souhaité, puis marquez la position des quatre trous de vis avec un crayon. (Voir Figure 1)

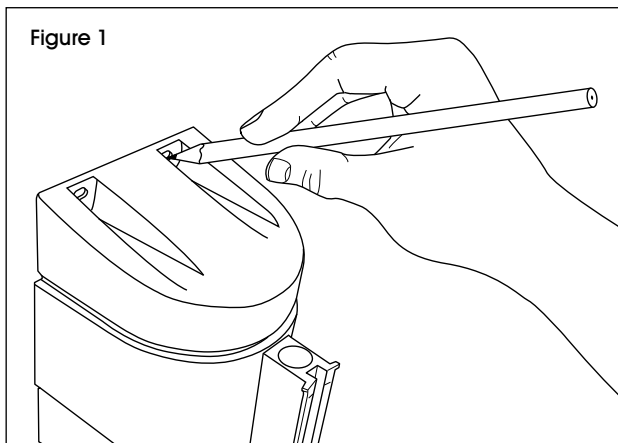

**AVERTISSEMENT!** Avant de percer le mur, vérifiez qu'il n'y a pas de câbles électriques ou de tuyaux de plomberie dans la surface.

2. Percez quatre trous aux emplacements marqués avec une mèche de perceuse de 17/64 po. (Voir Figure 2)

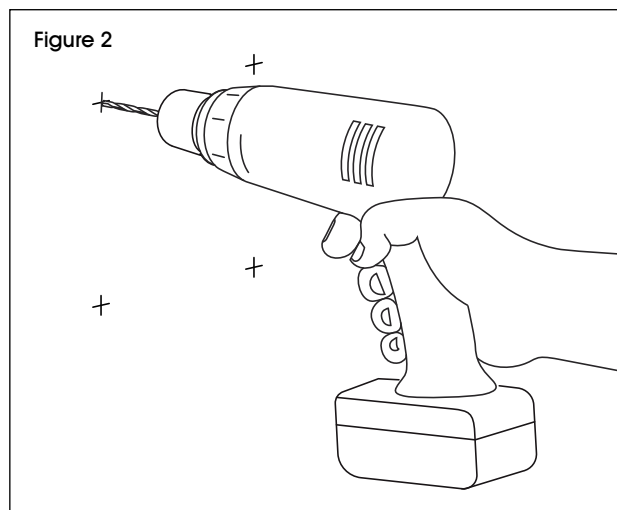

## INSTALLATION SUITE

- Insérez un ancrage mural (inclus) dans chacun des trous en vous assurant que l'ancrage est pleinement inséré dans le mur. (Voir Figure 3)

 **REMARQUE :** Cette étape peut nécessiter un léger coup de marteau.

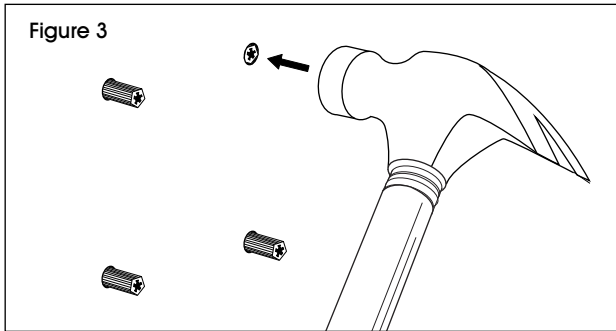

- Placez le dispositif à fixation murale sur les trous de vis et fixez le dispositif au mur à l'aide des vis fournies. (Voir Figure 4)

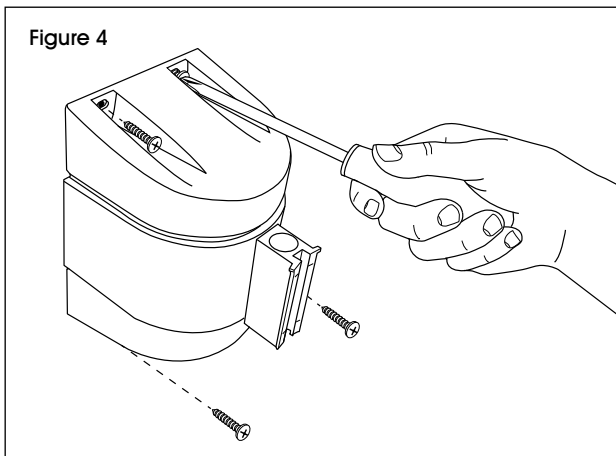

- Fixez les capuchons supérieur et inférieur sur le dispositif. (Voir Figure 5)

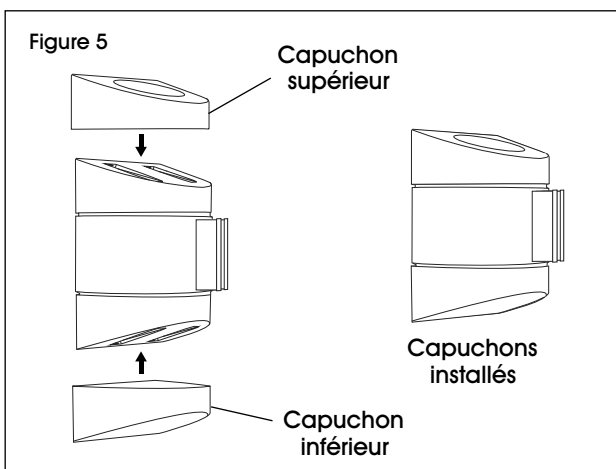

- Attachez le récepteur mural à l'extrémité de la sangle et tirez la sangle jusqu'au mur opposé. (Voir Figure 6)

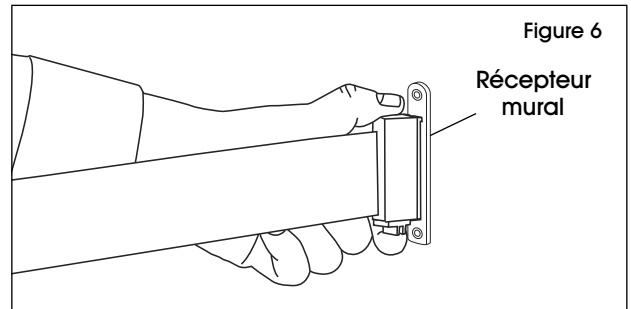

- Utilisez un crayon pour marquer l'emplacement des trous de vis du récepteur mural. (Voir Figure 7)

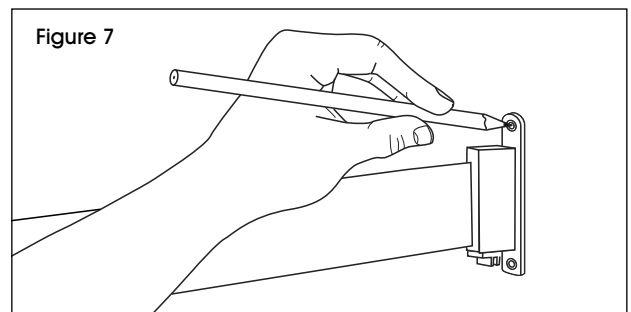

- Percez deux trous aux emplacements marqués avec la mèche de perceuse de 17/64 po. (Voir Figure 8)

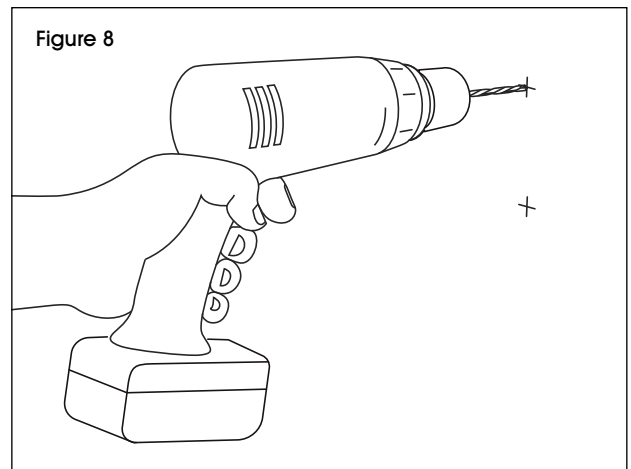



## INSTALLATION SUITE

9. Insérez un ancrage mural dans chacun des trous en vous assurant que l'ancrage repose contre la surface du mur. (Voir Figure 9)

 **REMARQUE :** Cette étape peut nécessiter un léger coup de marteau.

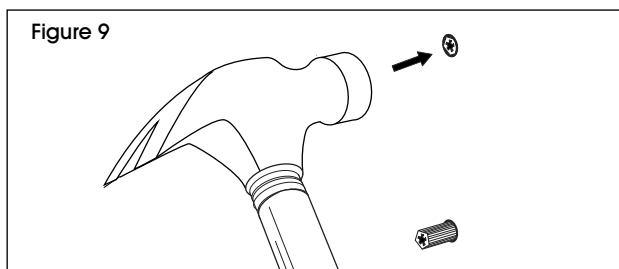

10. Placez le récepteur mural sur les trous et fixez-le en place avec les vis fournies. (Voir Figure 10)

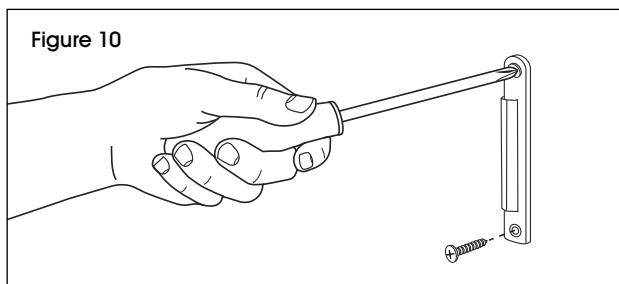

## INSTALLATION ET RETRAIT DES CAPUCHONS

### INSTALLATION

1. Faites glisser le capuchon en position en le poussant vers le bas. (Voir Figure 11)

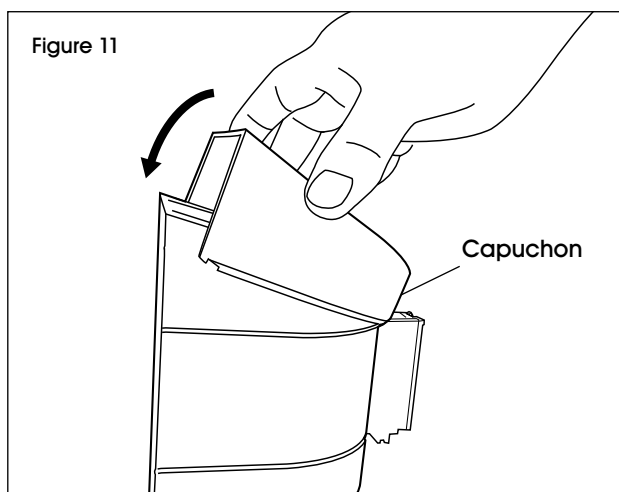

2. Encliquez les languettes de verrouillage en place. Appuyez sur les côtés pour repérer les languettes si nécessaire. (Voir Figure 12)

 **REMARQUE :** Appuyez sur les côtés pour bien positionner la languette de verrouillage.



### RETRAIT

1. Insérez un tournevis à tête plate ou un autre outil entre le capuchon et le boîtier. Tournez pour dégager les languettes de verrouillage du cliquet de chaque côté. (Voir Figure 13)

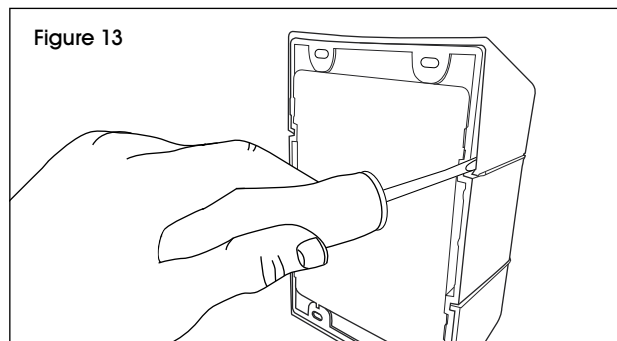

2. Faites glisser le capuchon en l'écartant du mur pour le retirer. (Voir Figure 14)

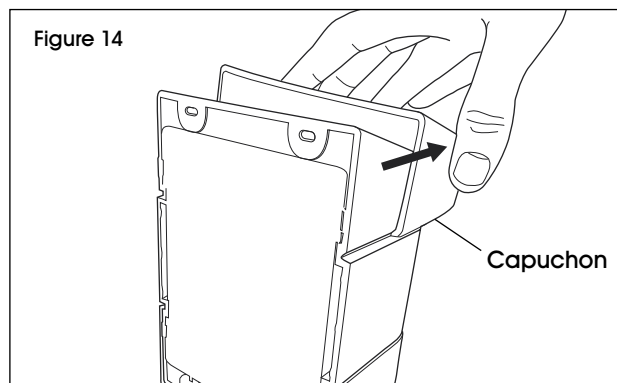

**ULINE**

1-800-295-5510  
uline.ca