

# ULINE H-5517

## SQUARE SIGN POST ANCHOR BASE

1-800-295-5510  
uline.com

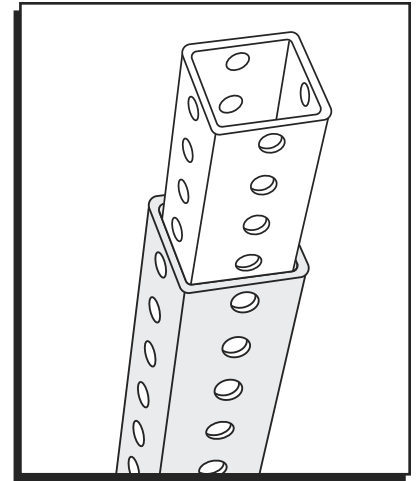

### INSTALLATION

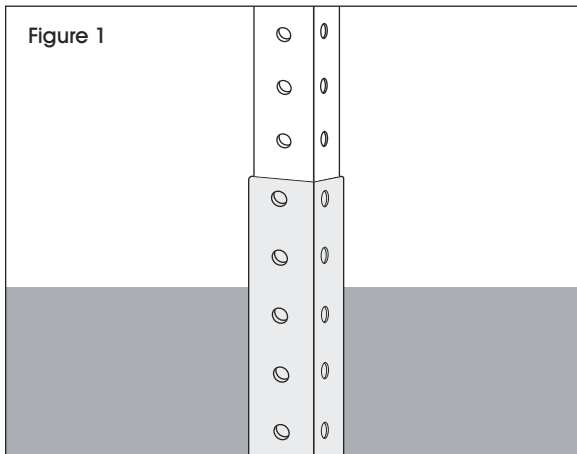

1. Drive anchor into ground, leaving 1-2 holes exposed. (See Figure 1)
2. Insert square sign post into anchor. (See Figure 1)



**NOTE:** Post should be installed 6-10 holes into anchor.

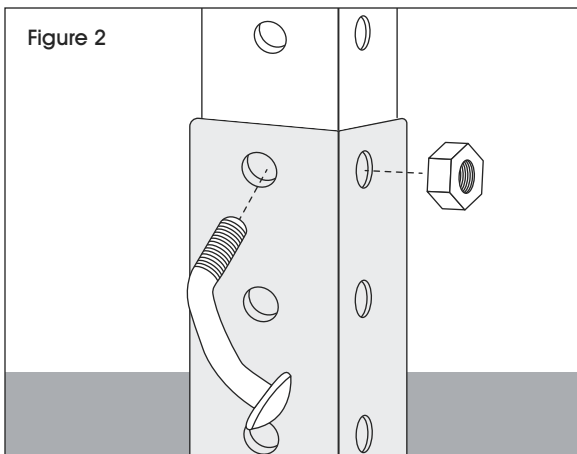

3. Use a corner bolt to secure post to anchor.



**NOTE:** Install corner bolt through back hole, opposite the flow of traffic. (See Figure 2)



**NOTE:** Corner bolt is not included.

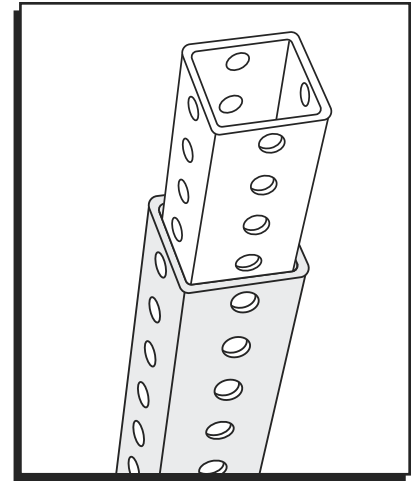

## INSTALACIÓN

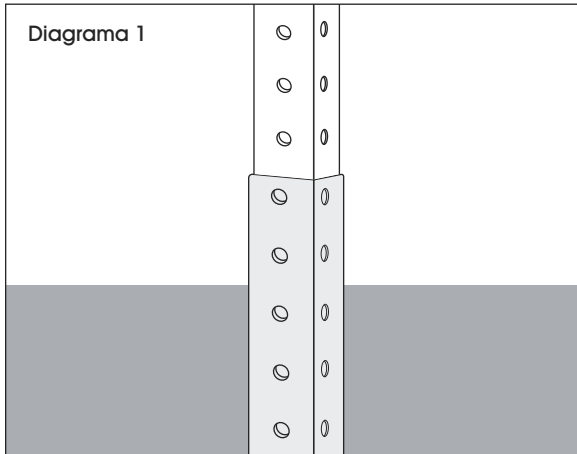

1. Entierre la base de apoyo en el suelo, dejando 1-2 orificios expuestos. (Vea Diagrama 1)
2. Inserte el poste cuadrado para señalamientos en la base. (Vea Diagrama 1)



**NOTA:** El poste se debe instalar de 6-10 orificios dentro de la base.

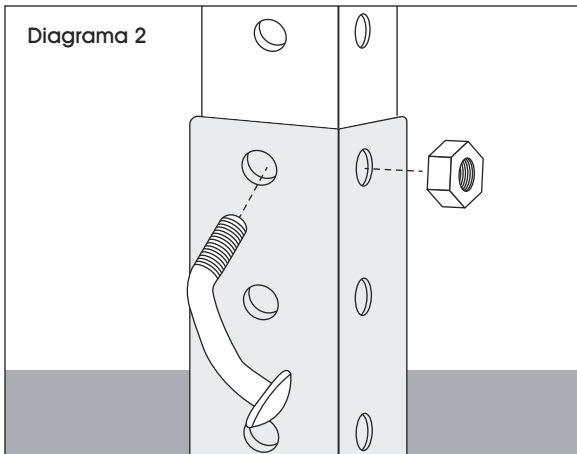

3. Use un perno de esquina para asegurar el poste a la base.



**NOTA:** Instale el perno de esquina por el orificio posterior, en sentido opuesto al tráfico. (Vea Diagrama 2)



**NOTA:** Perno de esquina no incluido.

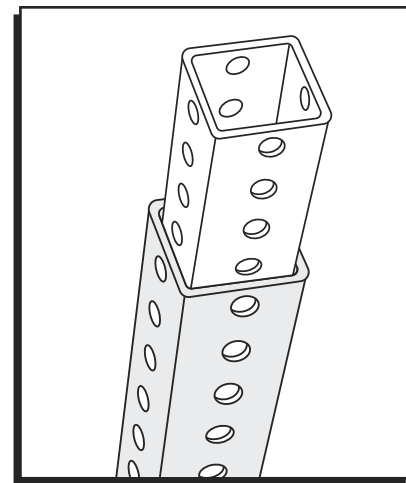

## INSTALLATION

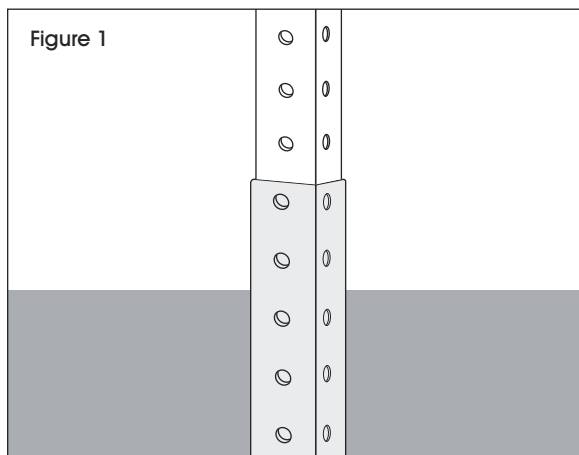

1. Enfoncez l'ancrage dans le sol en laissant un ou deux trous à découvert. (Voir Figure 1)
2. Insérez le poteau carré dans l'ancrage. (Voir Figure 1)



**REMARQUE :** Le poteau doit être installé à une profondeur de six à dix trous dans l'ancrage.

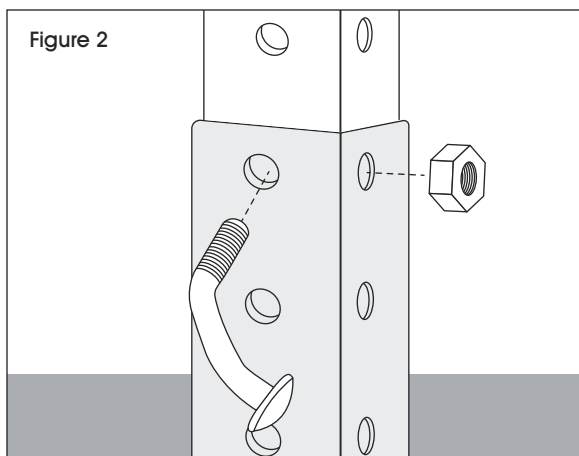

3. Utilisez un boulon de coin pour fixer le poteau à l'ancrage.



**REMARQUE :** Installez le boulon de coin en le passant dans le trou arrière, à l'opposé du sens de la circulation. (Voir Figure 2)



**REMARQUE :** Le boulon de coin n'est pas inclus.