

ULINE H-5580, H-5581, H-5582 H-5583, H-5584, H-5585 BALL TRANSFER TABLES

1-800-295-5510
uline.com

TOOL NEEDED

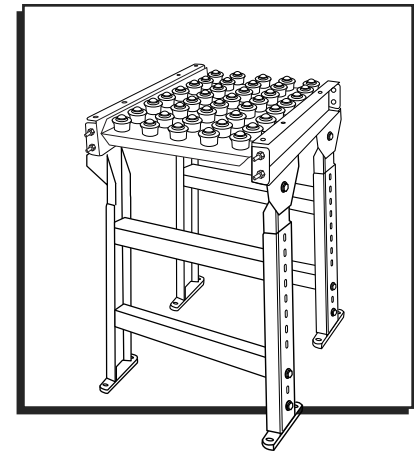

ASSEMBLY

BOLTING TABLE FRAME(S) TO H-STAND LEG SUPPORTS

 **NOTE:** H-Stands are sold separately. Hardware included: four hex head bolts and four flange nuts.

1. Hardware is pre-screwed into the tops of the H-Stands. Remove the hardware. (See Figure 1)

Figure 1

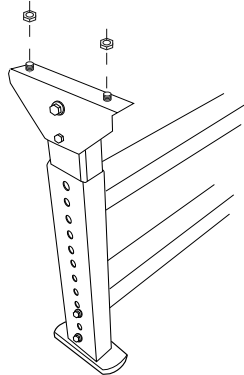

2. Bolting two H-Stands to one table frame: Position H-Stands on the end of the table frame. Fasten bolts through table and H-Stand. (See Figure 2)

Figure 2

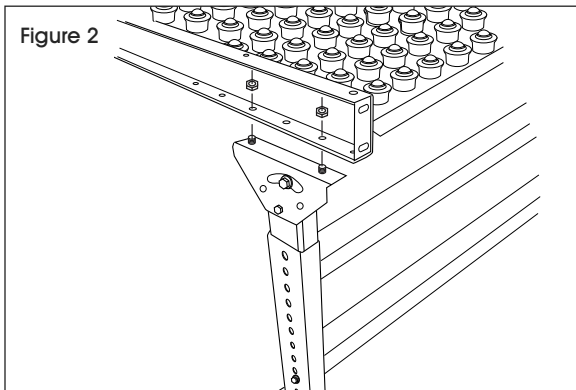

3. Bolting a single H-Stand to two table frames: Position the H-Stand halfway between the ends of two table frames, aligning one hole on each table with the H-Stand. Fasten bolts through tables and H-Stand. (See Figure 3)

 **NOTE:** Each table frame includes mounting holes for an optional center leg support. Adding a third support increases weight capacity.

Figure 3



ASSEMBLY CONTINUED

CONNECTING MULTIPLE TABLES TOGETHER

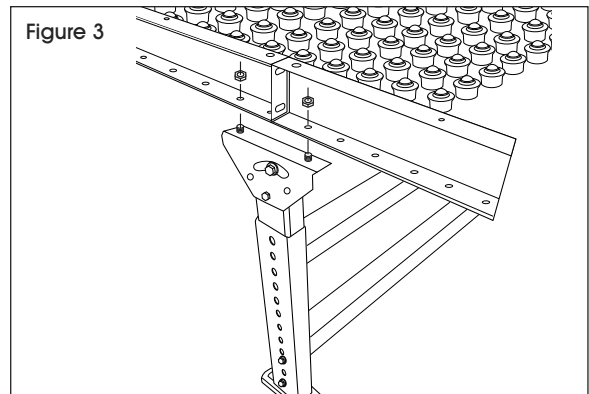
1. Remove pre-screwed hardware. Fasten bolts through the ends of both frames. (See Figure 4).

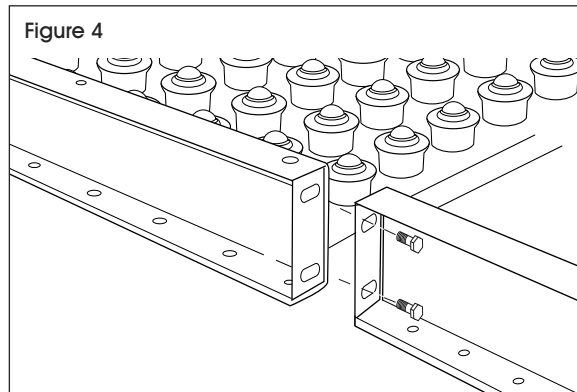

ULINE

1-800-295-5510
uline.com

ULINE H-5580, H-5581, H-5582
H-5583, H-5584, H-5585
**MESA DE TRANSFERENCIA
CON BOLAS**

800-295-5510
uline.mx

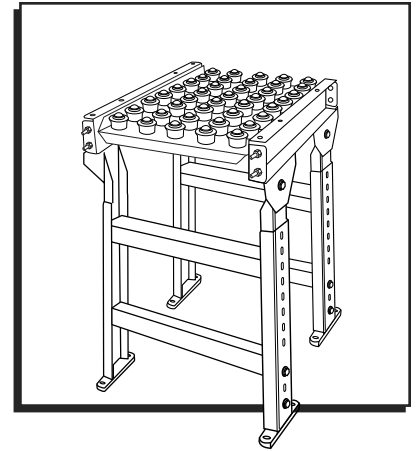

HERRAMIENTA NECESARIA



Llave de 14 mm (9/16")

ENSAMBLE

ATORNILLE LOS MARCOS DE LA MESA A LOS SOPORTE(S) EN H

 **NOTA:** Los soportes en H se venden por separado. Tornillería incluida: cuatro pernos de cabeza hexagonal y cuatro tuercas de brida.

1. La tornillería está preatornillada en la parte superior de los Soportes en H. Retire la tornillería. (Vea Diagrama 1)

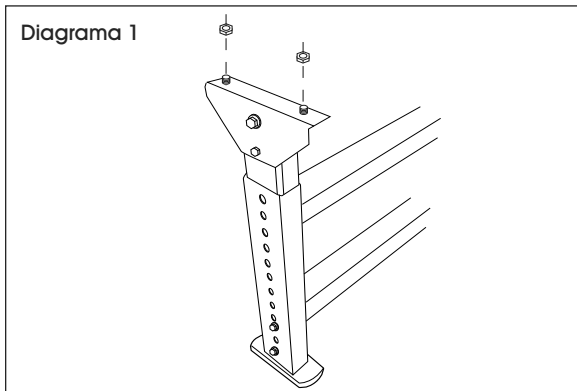

2. Atornille dos Soportes en H a un marco de la mesa: Posicione el Soporte en H en el extremo del marco de la mesa. Apriete los pernos a través de la mesa y los Soportes en H. (Vea Diagrama 2)

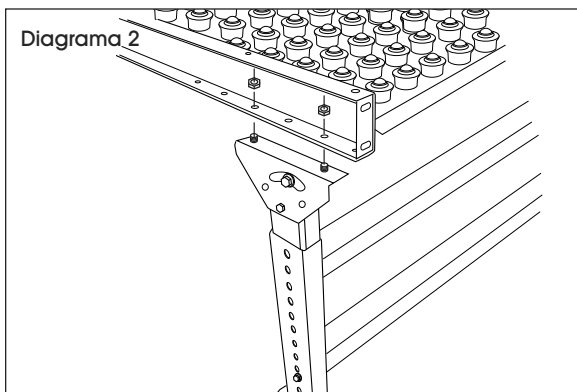

3. Atornille un Soporte en H dos marcos de la mesa: Coloque el Soporte en H entre los extremos de los marcos de la mesa, alineando un orificio en cada mesa con el Soporte en H. Apriete los pernos a través de las mesas y el Soporte en H. (Vea Diagrama 3)

 **NOTA:** Cada marco de mesa incluye orificios para instalación para una pata de soporte opcional. Agregar el tercer soporte incrementa la capacidad de peso.

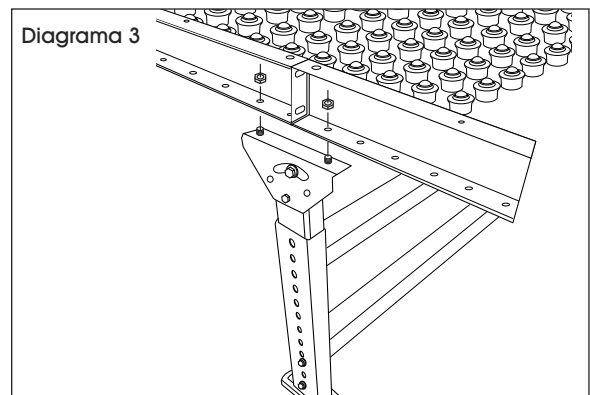

CONTINUACIÓN DE ENSAMBLE

CONECTE VARIAS MESAS

1. Quite la tornillería preinstalada. Apriete los pernos a través de los extremos de ambos marcos. (Vea Diagrama 4)

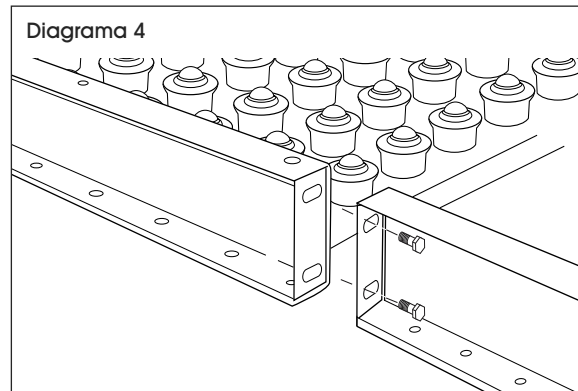

ULINE

800-295-5510

uline.mx

TABLE À BILLES POUR CONVOYEUR

OUTIL REQUIS

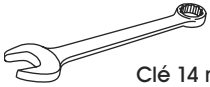

Clé 14 mm (9/16 po)

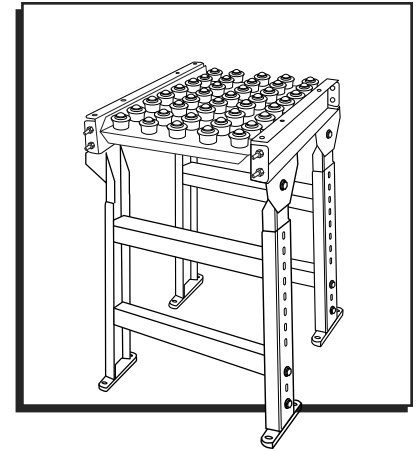

MONTAGE

BOULONNER UN/DES CADRE(S) DE TABLE AUX PATES DE SOUTIEN DES SUPPORTS EN H

 **REMARQUE :** Les supports en H sont vendus séparément. Matériel inclus : quatre boulons à tête hexagonale et quatre écrous à embase.

1. Le matériel est préinstallé dans les parties supérieures des supports en H. Veuillez retirer ce matériel installé. (Voir Figure 1)

Figure 1

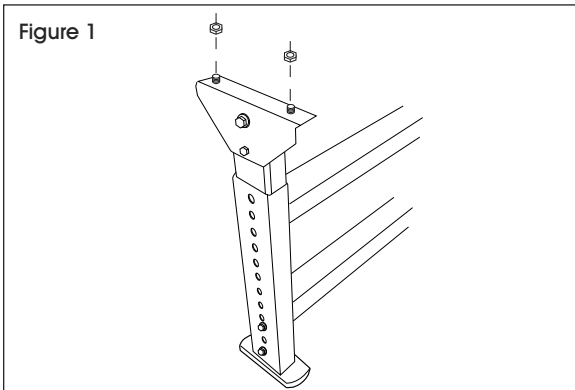

2. **Fixation de deux supports en H à un cadre de table:** Positionnez les supports en H à l'extrémité du cadre de table. Fixez la table aux supports en H à l'aide de boulons. (Voir Figure 2)

Figure 2

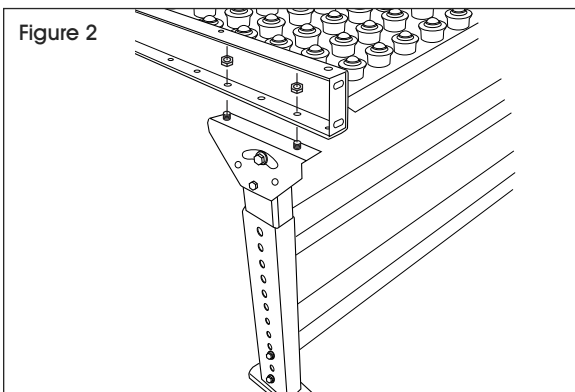

3. **Fixation d'un seul support en H à deux cadres de table:** Positionnez le support en H à mi-parcours entre les extrémités de deux cadres de table en vous assurant de faire coïncider un trou situé sur chacune des tables avec le support en H. Fixez les boulons en les faisant passer à travers les tables et le support en H. (Voir Figure 3)

 **REMARQUE :** Chaque cadre de table possède des trous d'assemblage pour un support central optionnel. La capacité de poids augmente avec l'ajout d'un troisième support.

Figure 3



MONTAGE SUITE

RACCORDEMENT DE PLUSIEURS TABLES ENTRE ELLES

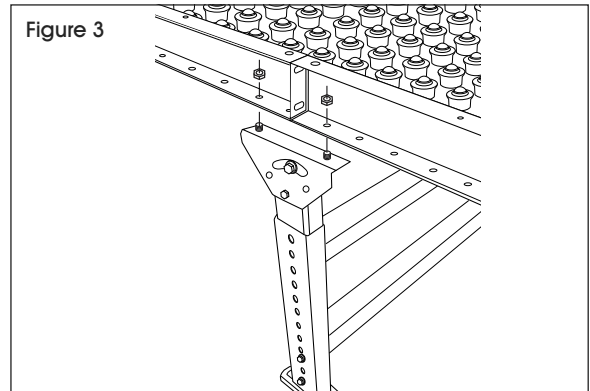
1. Retirez les pièces de fixation prévisées. Fixez les boulons aux extrémités des deux cadres. (Voir Figure 4)

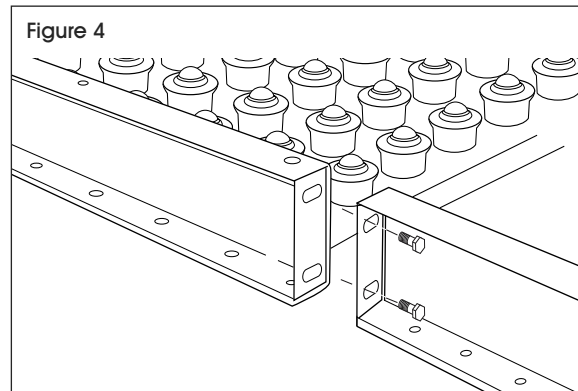

ULINE

1 800 295-5510
uline.ca