

ULINE H-5685

STEEL DESK – DOUBLE PEDESTAL

1-800-295-5510
uline.com

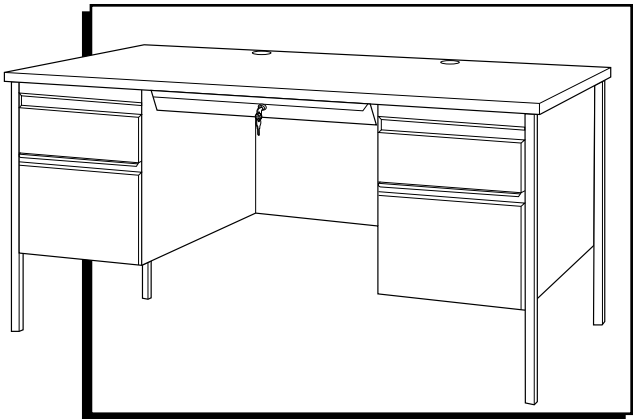

TOOL NEEDED

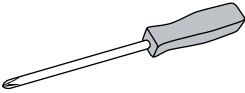

Phillips Screwdriver



Two Person Assembly
Recommended

PARTS

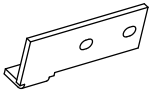

Leg Bracket x 4



Leg x 4

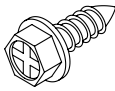

Screw x 8
#8 x 1/2"

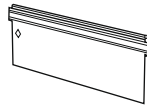

Drawer Divider x 2



Grommet x 2



Key x 2

ASSEMBLY



NOTE: Assemble on smooth, non-marring surface to avoid scratching.



NOTE: Check that all parts are included. Remove contents from drawer before assembling.



WARNING! Take care when handling metal parts. Sharp edges may cause injury.

1. Lock drawers. With two people, turn desk upside down.
2. Place open end of leg over alignment peg on bottom of desktop at corner. (See Figure 1)

Figure 1

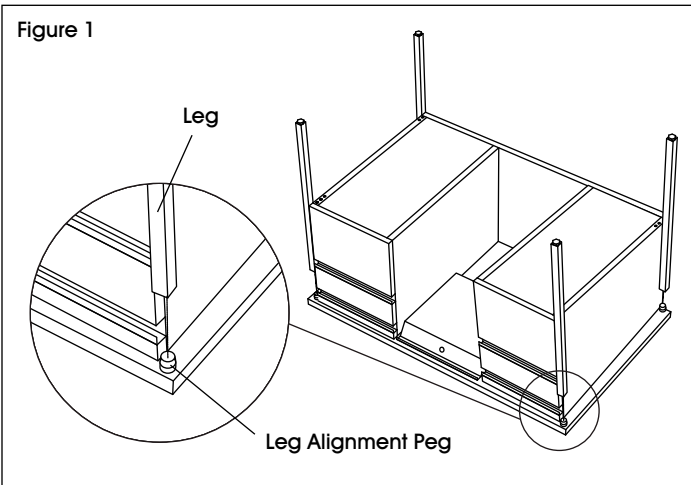

3. Insert one leg bracket into the corresponding slot in leg. (See Figure 2)



NOTE: Bracket may flip up or down, depending on which leg user is installing.

Figure 2

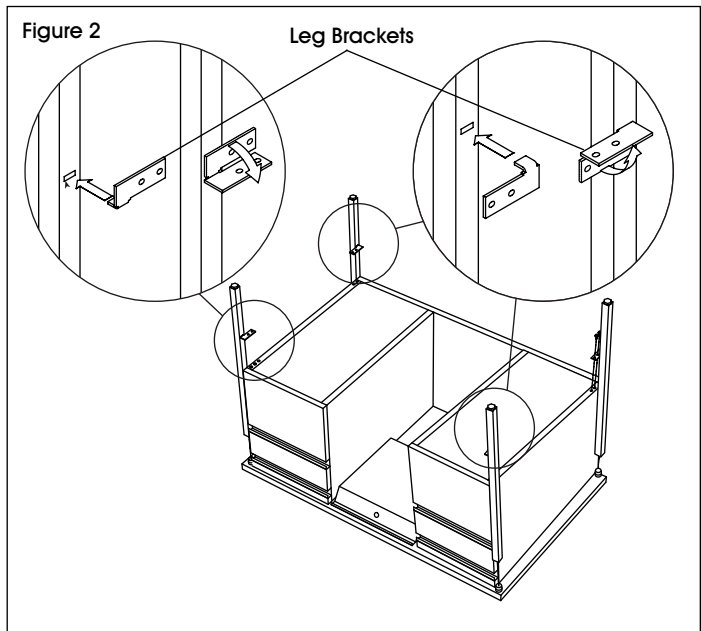

ASSEMBLY CONTINUED

4. Align leg bracket with holes in pedestal file. Use two #8 x 1/2" screws to secure. Repeat for remaining legs. (See Figure 3)

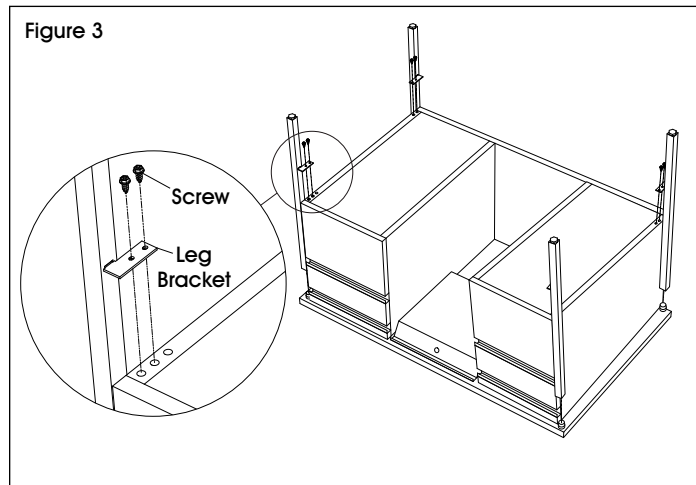

5. With two people, set desk upright and position in desired location. Adjust leveling glides as needed.
6. Place drawer dividers at desired locations in top drawers and insert grommets into desktop.

ULINE

1-800-295-5510
uline.com

ULINE H-5685

ESCRITORIO DE ACERO – DOBLE PEDESTAL

800-295-5510
uline.mx

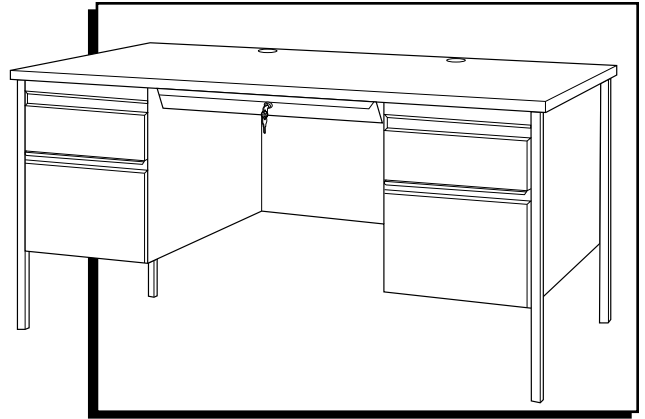

HERRAMIENTA NECESARIA

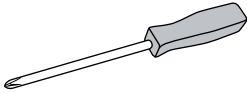

Desarmador de Cruz



Se recomienda Armar
Entre Dos Personas

PARTES

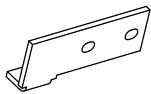

4 Soportes para Patas



4 Patas

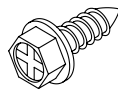

8 Tornillos #8 x 1/2"

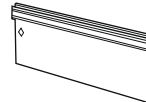

2 Divisores de Cajón



2 Ojales



2 Llaves

ENSAMBLE



NOTA: Ensamble sobre una superficie lisa que no deje marcas para evitar rayones.



NOTA: Verifique que todas las partes estén incluidas. Retire el contenido del cajón antes de ensamblar.



¡ADVERTENCIA! Debe tener cuidado cuando manipule piezas de metal. Los bordes filosos pueden causar lesiones.

1. Cierre los cajones con llave. Con la ayuda de dos personas, voltee el escritorio boca abajo.
2. Coloque el extremo abierto de la pata sobre la clavija de alineamiento en la esquina de la parte inferior del escritorio. (Vea Diagrama 1)

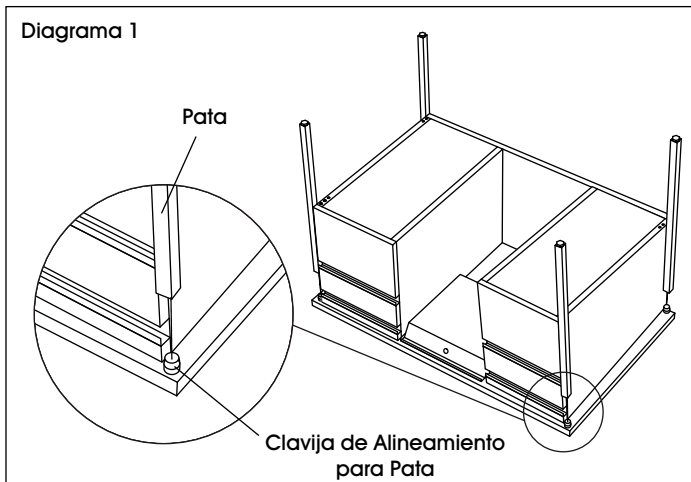

3. Inserte un soporte para pata en la ranura correspondiente de la pata. (Vea Diagrama 2)



NOTA: El soporte podría voltearse hacia arriba o abajo dependiendo de la pata que el usuario utilice.

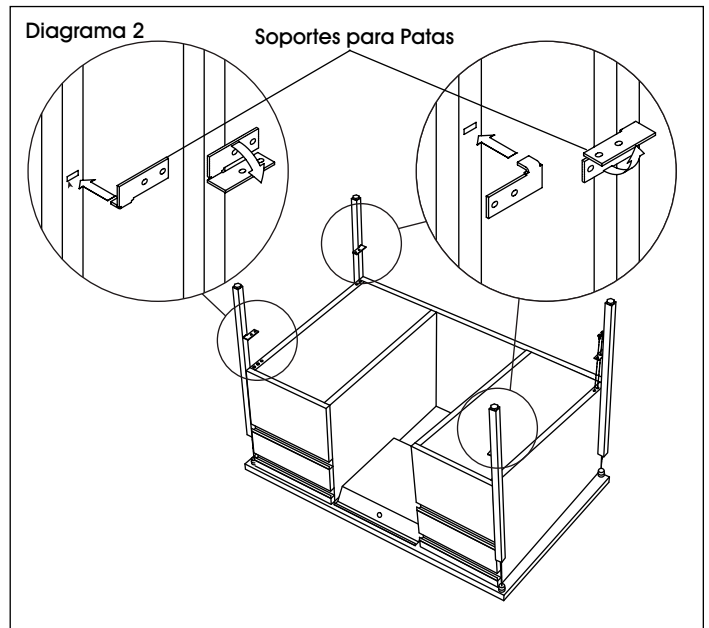

CONTINUACIÓN DEL ENSAMBLE

4. Alinee el soporte para pata con los orificios del archivero de pedestal. Utilice dos tornillos #8 x 1/2" para asegurarlo. Repita la operación con las patas restantes. (Vea Diagrama 3)

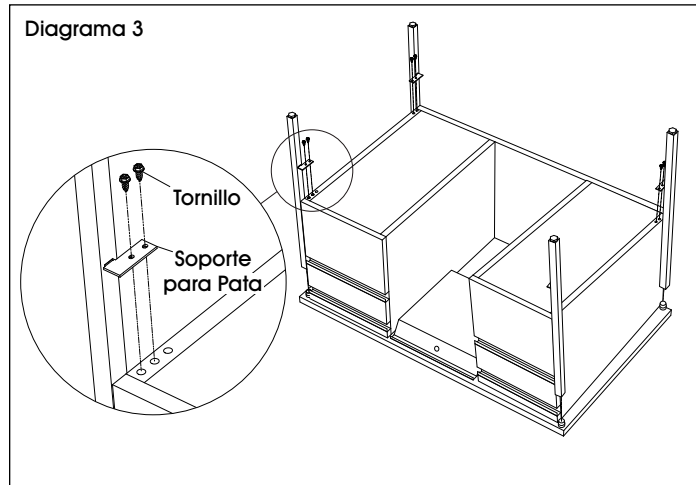

5. Con la ayuda de dos personas, enderece el escritorio y colóquelo en la ubicación deseada. Ajuste las patas de nivelación como se requiera.
6. Coloque los divisores en los cajones superiores e inserte los ojales en el escritorio.

ULINE

800-295-5510
uline.mx

ULINE H-5685

BUREAU EN ACIER À DOUBLE CAISSON

1-800-295-5510
uline.ca

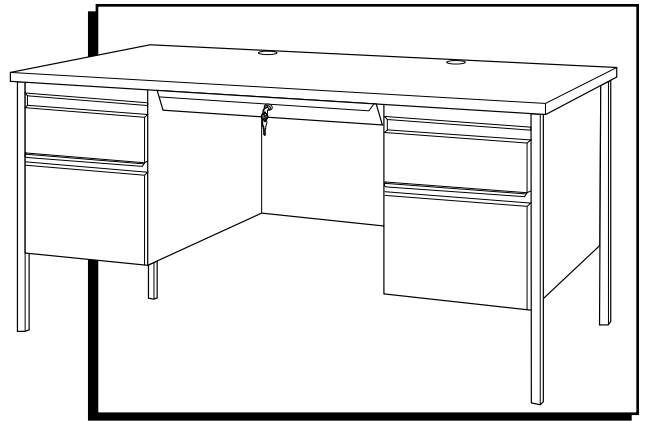

OUTIL REQUIS

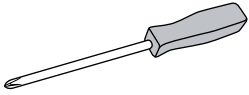

Tournevis cruciforme



Montage à deux personnes recommandé

PIÈCES

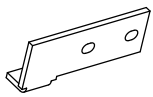

Support de pied x 4



Pied x 4

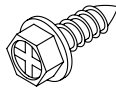

Vis n° 8 x 1/2 po x 8

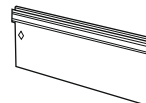

Séparateur de tiroir x 2

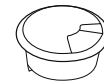

Passe-fil x 2



Clé x 2

MONTAGE



REMARQUE : Montez le bureau sur une surface lisse qui ne marque pas afin d'éviter les rayures.



REMARQUE : Vérifiez que toutes les pièces sont incluses. Retirez le contenu du tiroir avant le montage.



AVERTISSEMENT! Faites preuve de vigilance lors de la manipulation de pièces métalliques. Les bords tranchants peuvent causer des blessures.

1. Verrouillez les tiroirs. À deux, tournez le bureau à l'envers.
2. Placez l'extrémité ouverte d'un pied sur le taquet d'alignement dans l'un des coins sous le bureau. (Voir Figure 1)

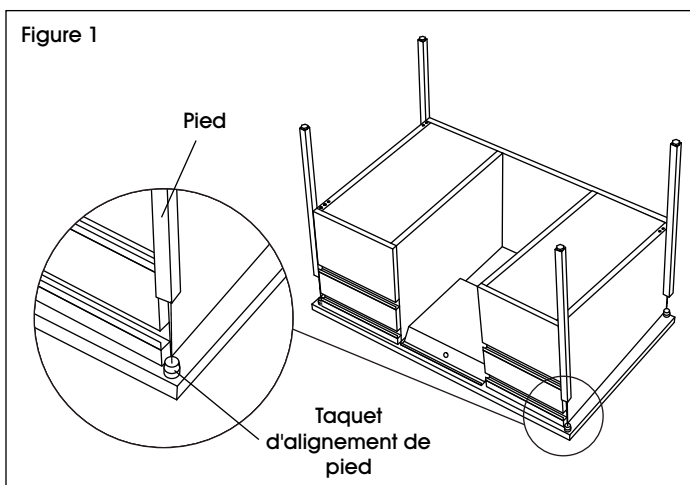

3. Insérez un support de pied dans la fente correspondante du pied. (Voir Figure 2)



REMARQUE : Le support peut basculer vers le haut ou vers le bas, selon le pied installé par l'utilisateur.

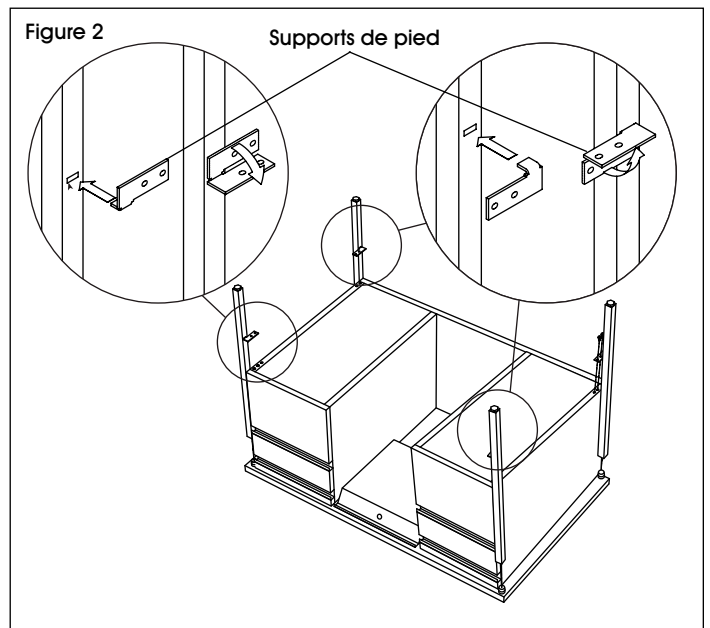

MONTAGE SUITE

- Alignez un support de pied sur les trous du classeur à caisson. Fixez avec deux vis n° 8 x 1/2 po. Répétez cette étape pour les autres pieds. (Voir Figure 3)

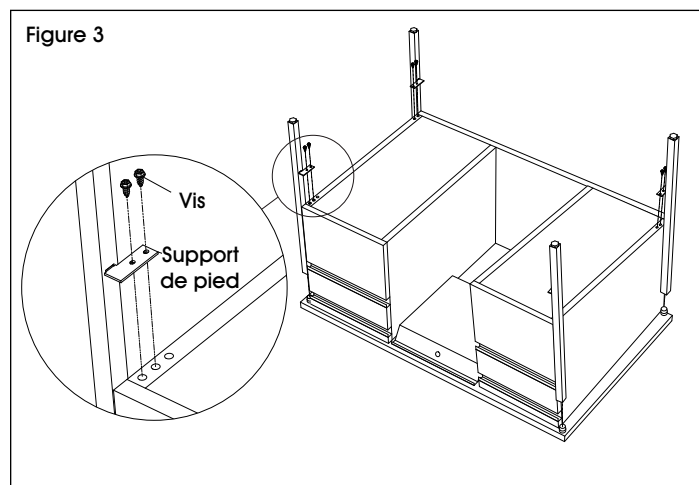

- À deux, mettez le bureau à l'endroit et placez-le à l'emplacement souhaité. Ajustez les patins de nivellement au besoin.
- Placez les séparateurs de tiroir aux endroits souhaités dans les tiroirs supérieurs et insérez les passe-fils dans le bureau.

ULINE

1-800-295-5510
uline.ca