

ULINE H-5799, H-5800 SEMI-RECESSED FIRE EXTINGUISHER CABINET

1-800-295-5510
uline.com

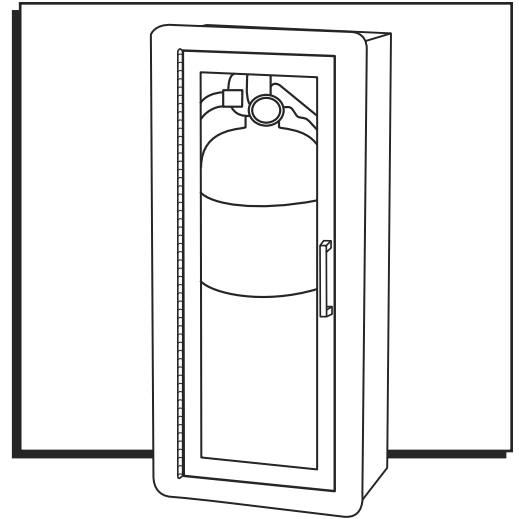

TOOLS NEEDED



Drill

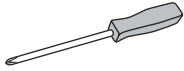

Phillips Head Screwdriver

PARTS



Plexiglass Window x 1

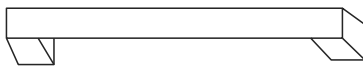

Handle x 1

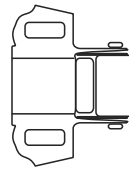

Latch x 1



Flat-End Bolt x 2

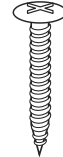

Screw x 6

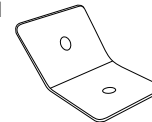

Bracket x 4

MOUNTING

MOUNTING DIAGRAM (TOP VIEW)

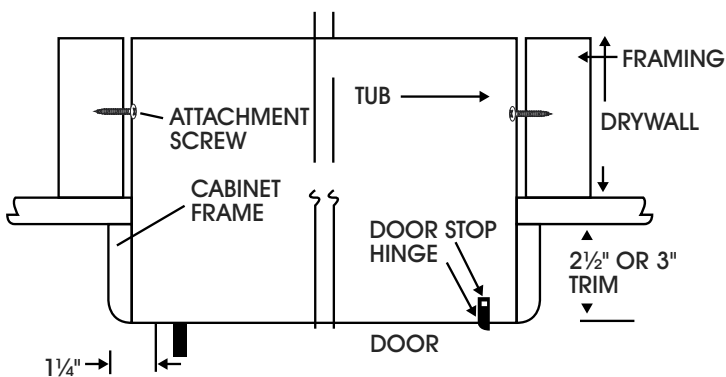

NOTE: On load-bearing walls, the studs must be doubled on either side of the cabinet tub. If a stud must be cut to install the cabinet, a load-bearing header must be installed in the cabinet tub.

1. Remove everything from inside cabinet.
2. Build a frame around the cabinet inside the wall to ensure structural stability.
3. Place cabinet in position and mark location of attachments on studding using holes in cabinet as marking guides. Cabinet must be attached by at least four points, two of which must be in studs.
4. Remove cabinet and drill 5/32" holes through studs at marked points. Install plastic wall anchors in no more than 2 places if needed. For masonry walls, install expansion shields in wall at marked points.
5. Place cabinet in position and attach with universal #10 x 2 1/2" self-drilling screws (not included).
6. Check cabinet door assembly for binding or gapping and shim as necessary.

ASSEMBLY

1. Remove protective film from plexiglass window and place it on inside of door. Secure window to door using Phillips head screwdriver, four brackets and screws. Do not over tighten. (See Figure 1)

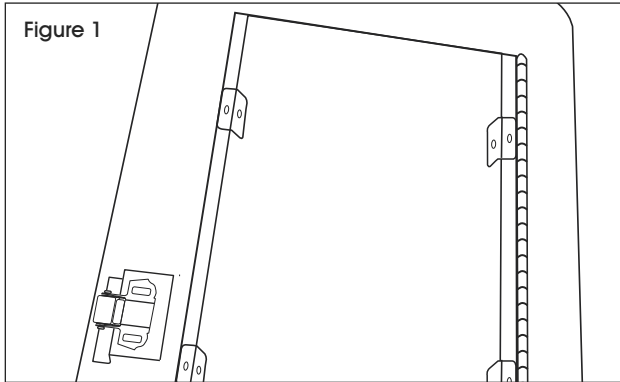

3. Attach latch to inside of door using Phillips head screwdriver and two screws. (See Figure 3)

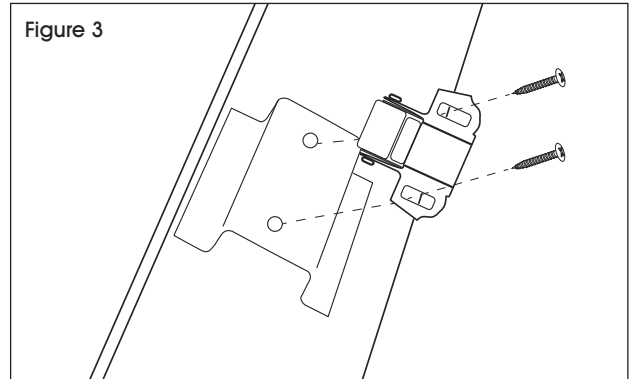

2. Attach handle to door using Phillips head screwdriver and two flat-end bolts. (See Figure 2)

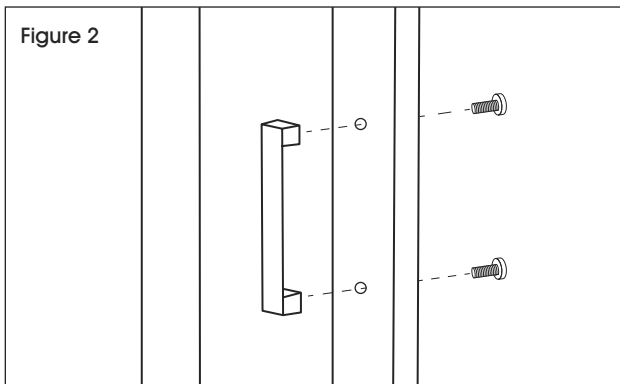

ULINE H-5799, H-5800

800-295-5510

uline.mx

GABINETE PARA EXTINTORES SEMIEMPOTRADO

HERRAMIENTAS NECESARIAS



Taladro

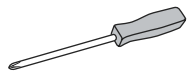

Desarmador de Cruz

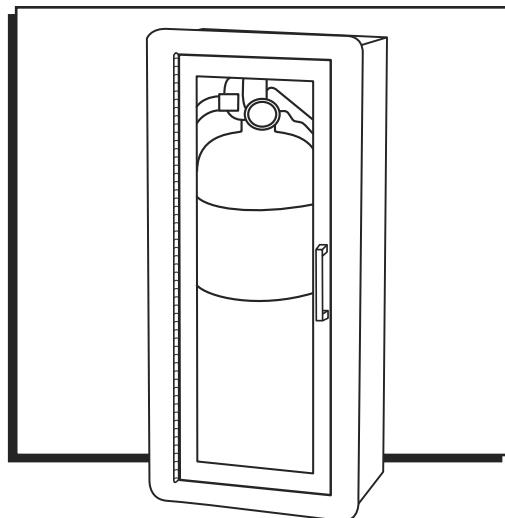

PARTES



1 Ventana de Plexiglás

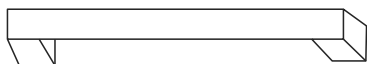

1 Asa

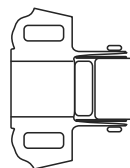

1 Pestillo



2 Pernos con Extremo Plano

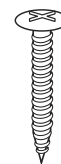

6 Tornillos

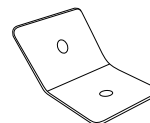

4 Soportes

INSTALACIÓN

DIAGRAMA DE INSTALACIÓN (VISTA DE LA PARTE SUPERIOR)

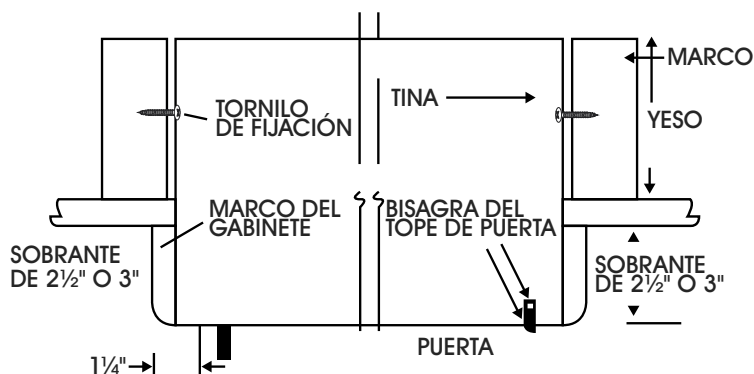

1. Saque todo el contenido del gabinete.
2. Construya un marco alrededor del gabinete, dentro de la pared para asegurar la estabilidad estructural.



NOTA: En los muros de carga, deberán multiplicarse por dos el número de remaches a ambos lados de la tina del gabinete. En caso de que se deba cortar algún remache para instalar el gabinete, deberá colocarse una barra de carga en la tina del gabinete.

3. Coloque el gabinete en la posición adecuada y marque la ubicación de los remaches usando los orificios del gabinete a modo de guía de marcado. El gabinete deberá fijarse con al menos cuatro puntos, dos de los cuales deben ser con remaches.
4. Quite el gabinete y taladre orificios de 39 mm (5/32") a través de los remaches en los puntos marcados. En caso de ser necesario, coloque anclajes de pared de plástico en un máximo de 2 lugares. En las paredes de mampostería, coloque taquetes de expansión en la pared en los puntos marcados.
5. Coloque el gabinete en posición y fíjelo con tornillos autorroscantes universales de #10 x 2 1/2" (no se incluyen).
6. Revise las uniones o separaciones del ensamble de la puerta del gabinete y ajuste, según sea necesario.

ENSAMBLE

1. Retire la película protectora de la ventana de plexiglás y colóquela en el interior de la puerta. Asegure la ventana a la puerta usando un desarmador de cruz, cuatro soportes y tornillos. No los apriete demasiado. (Vea Diagrama 1)

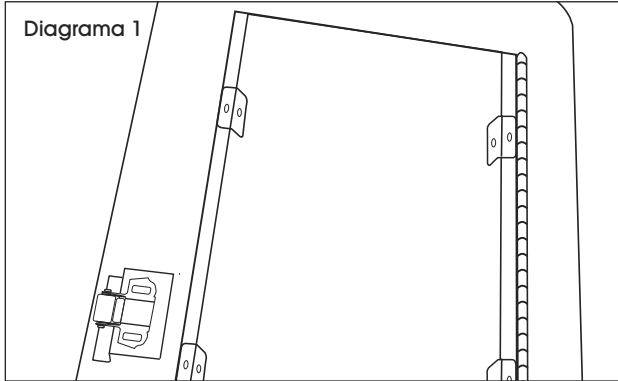

2. Fije el asa a la puerta usando el desarmador de cruz y dos pernos con extremo plano. (Vea Diagrama 2)

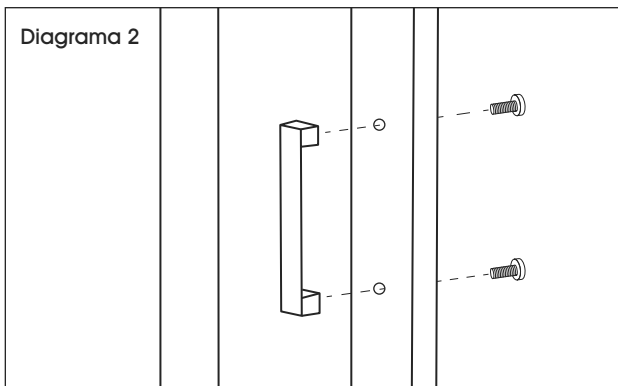

3. Fije el pestillo al interior de la puerta usando el desarmador de cruz y dos tornillos. (Vea Diagrama 3)

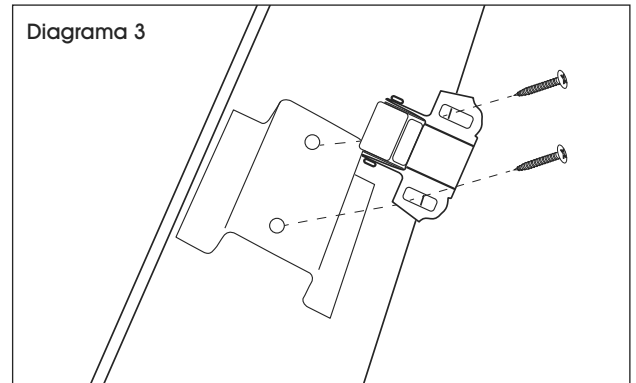

ULINE H-5799, H-5800

ARMOIRE À EXTINCTEUR SEMI-ENCASTRÉE

1-800-295-5510
uline.ca

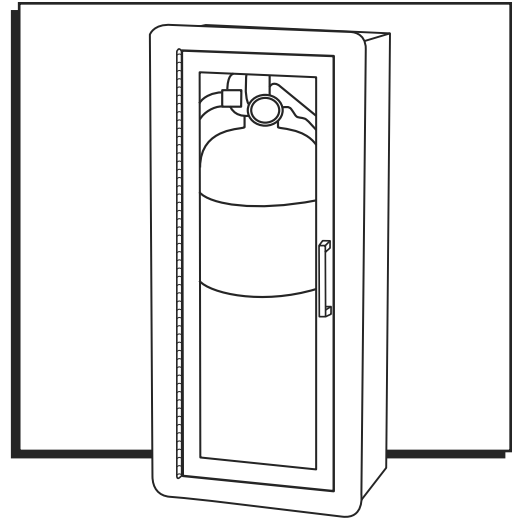

OUTILS REQUIS



Perceuse

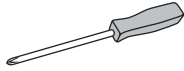

Tournevis cruciforme

PIÈCES



Vitre en plexiglas x 1

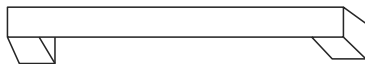

Poignée x 1

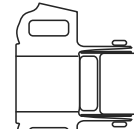

Loquet x 1



Boulon à tête plate x 2

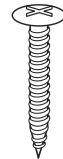

Vis x 6

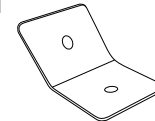

Support x 4

INSTALLATION

SCHEMA D'ASSEMBLAGE (VUE DU DESSUS)

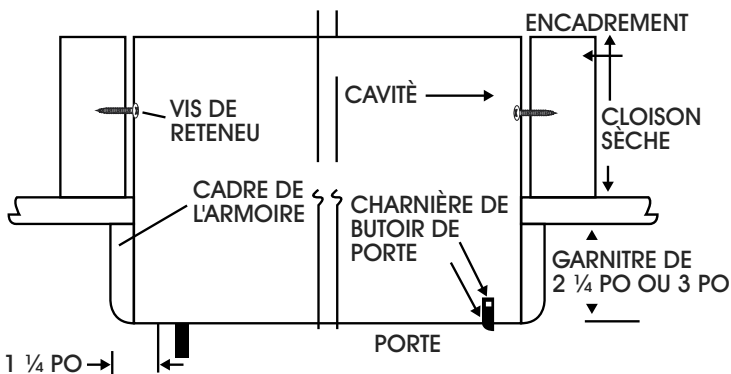

1. Retirez tous les éléments de l'intérieur de l'armoire.
2. Construisez un cadre qui entourera l'armoire à l'intérieur du mur afin d'assurer la stabilité structurelle.

REMARQUE : Sur les murs porteurs, les goujons doivent être doublés de chaque côté de la cavité de l'armoire. Si un goujon doit être coupé pour installer l'armoire, un linteau porteur doit être installé dans la cavité de l'armoire.

3. Mettez l'armoire en position et marquez l'emplacement des vis de retenue sur les goujons en utilisant les trous de l'armoire comme guides. L'armoire doit être fixée à au moins quatre endroits, dont deux par des goujons.
4. Retirez l'armoire et percez des trous de 39 mm (5/32 po) dans les goujons aux endroits marqués. Installez des ancrages muraux en plastique à deux endroits au maximum, si nécessaire. Pour les murs en maçonnerie, installez des coquilles d'expansion dans le mur aux endroits marqués.
5. Remettez l'armoire en position et fixez-la à l'aide de vis autoforeuses universelles n° 10 x 2 1/2 po.
6. Vérifiez la réliure et les interstices sur l'ensemble de la porte de l'armoire, posez des cales au besoin.

MONTAGE

1. Retirez la pellicule protectrice de la vitre en plexiglas et placez celle-ci à l'intérieur de la porte. Fixez la vitre à la porte à l'aide d'un tournevis cruciforme, de quatre supports et de vis. Évitez de les serrer excessivement. (Voir Figure 1)

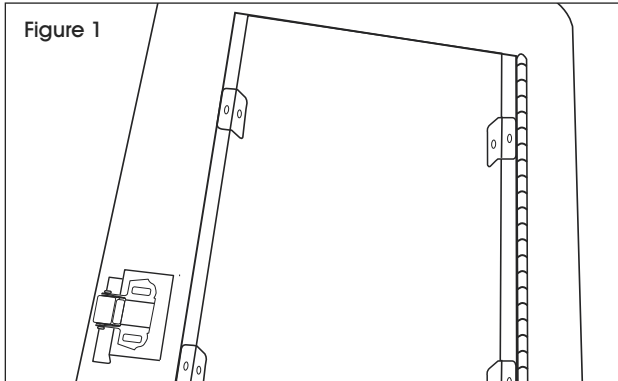

3. Fixez le loquet à l'intérieur de la porte à l'aide d'un tournevis cruciforme et de deux vis. (Voir Figure 3)

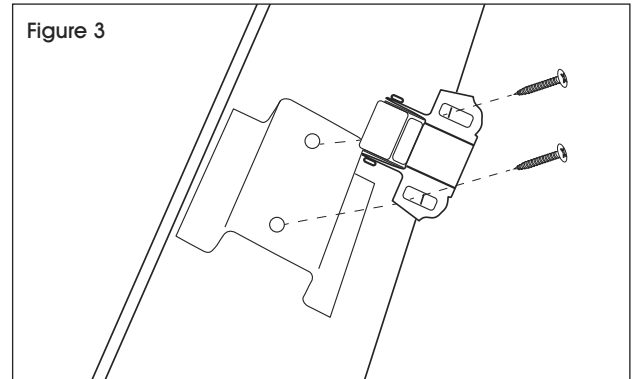

2. Fixez la poignée à la porte à l'aide d'un tournevis cruciforme et de deux boulons à tête plate. (Voir Figure 2)

