

ULINE H-5808

TORK® PLASTIC AUTOMATIC FOAM SOAP DISPENSER

1-800-295-5510
uline.com

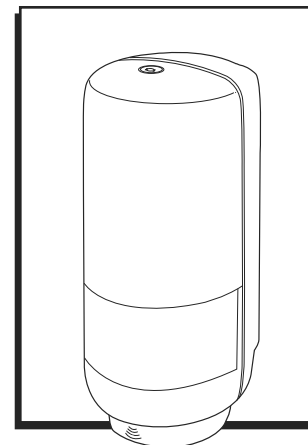

TOOLS NEEDED

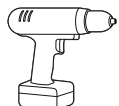

Drill



1/4" Drill Bit

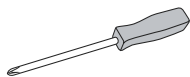

Phillips Screwdriver

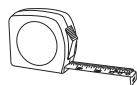

Tape Measure

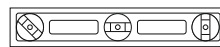

Level

PARTS

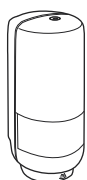

Dispenser x 1

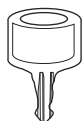

Key x 1



C-Cell Battery x 4
(not included)

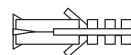

Wall Anchor x 4
(not included)



Screw x 4
(not included)

SAFETY

- Do not allow children to play with the dispenser.
- The minimum and maximum ambient temperatures for correct operation are 32-122°F.
- Dispenser is not suitable for installation outdoors or in wet environments. It is not water-resistant.
- Operating sound level of the dispenser is less than 70dBa.
- Damaged or malfunctioning product should be disposed of immediately to avoid injury.
- Product should be disposed of in accordance with applicable regulations.

INSTALLATION



NOTE: Install dispenser at least 6" above counter or sink.

1. Tape included template to wall to use as guide. Ensure template is level. (See Figure 1)

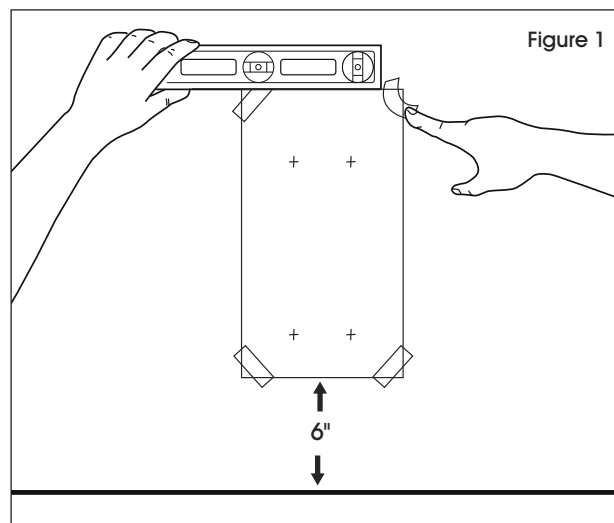

INSTALLATION CONTINUED

2. Drill four holes using 1/4" drill bit and remove template from wall. (See Figure 2)

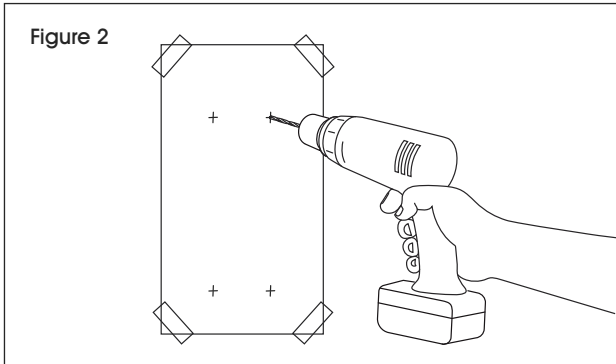

3. Insert anchors and screws. (See Figure 3)

 **NOTE:** Do not tighten screws completely until step 7.

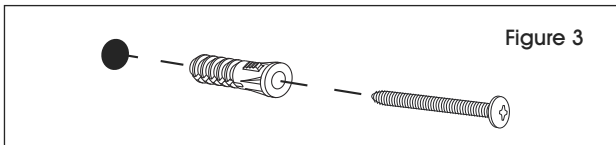

4. Open dispenser and remove cartridge by pressing top tab area and pulling outward. (See Figures 4-5)

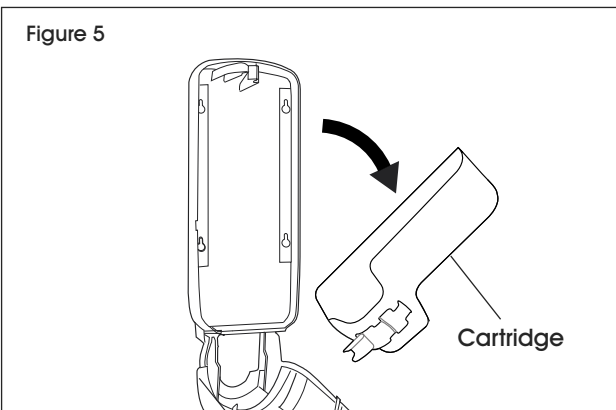
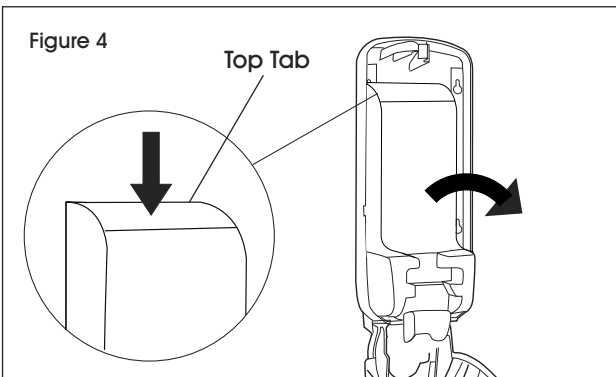

5. Hold dispenser up to wall and align holes over screws. (See Figure 6)

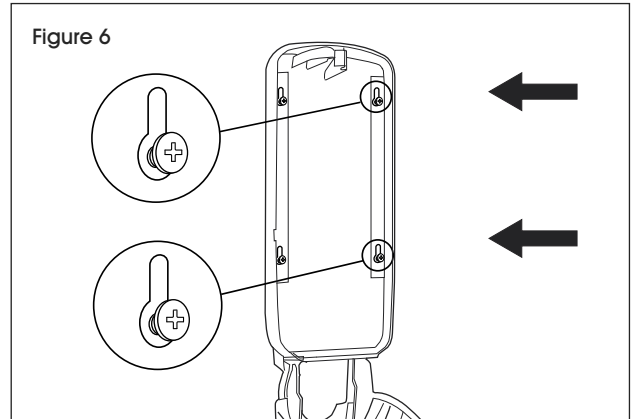

6. Lower dispenser onto screws. (See Figure 7)

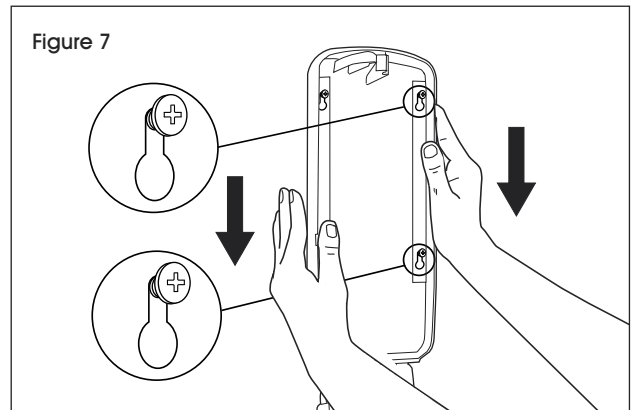

7. Tighten screws. (See Figure 8)

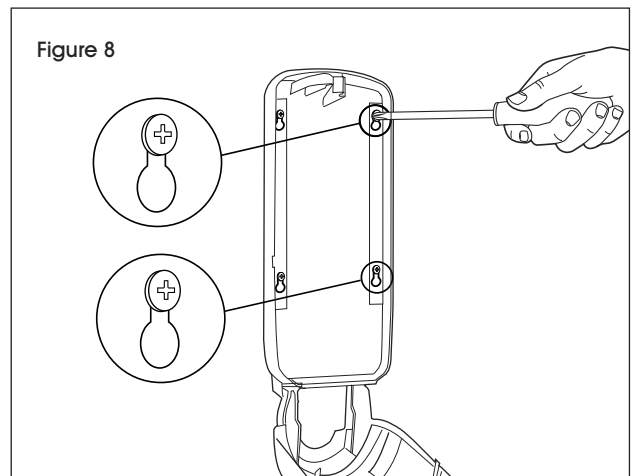

INSTRUCTIONS

LOADING

1. Load four batteries into back of cartridge. (See Figure 9)

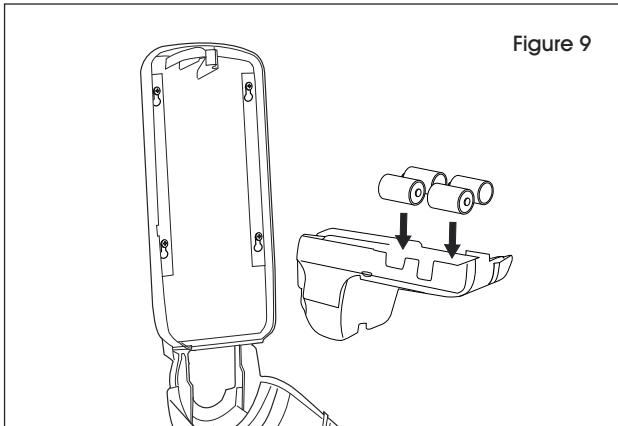

2. Replace cartridge into dispenser housing. Once inserted correctly, cartridge should click into place. (See Figures 10-11)

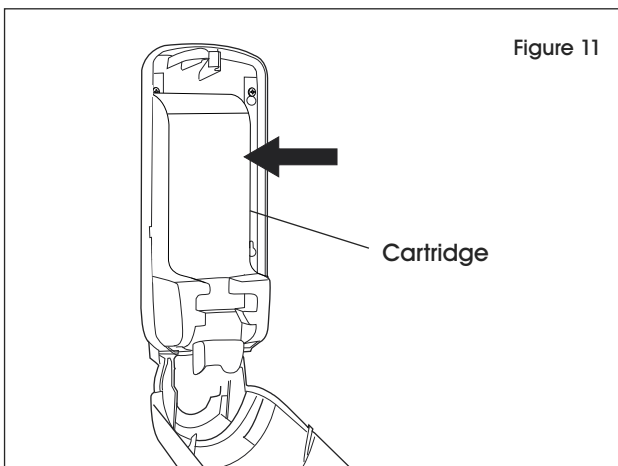
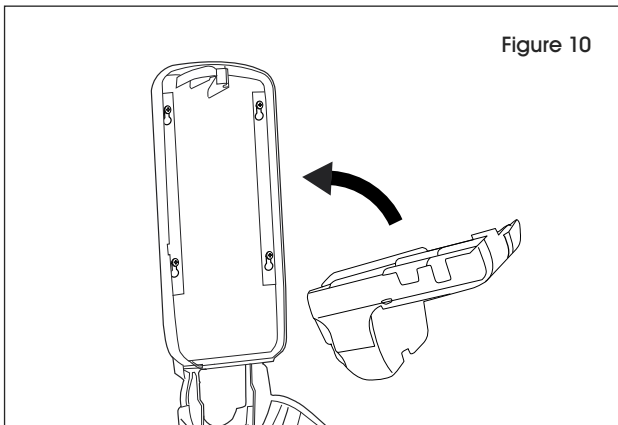

3. Before loading refill, twist nozzle in direction of arrows until it clicks. (See Figure 12)

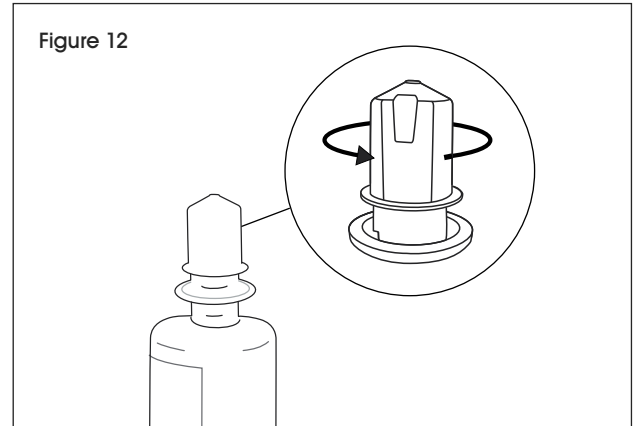

4. Flip refill upside down and load into cartridge with nozzle down. (See Figures 13-14)

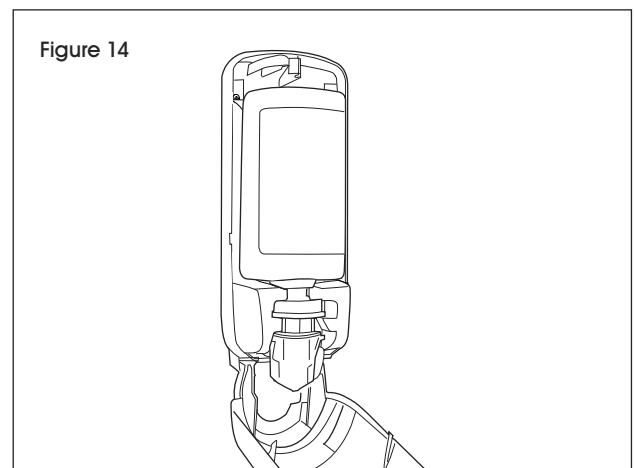
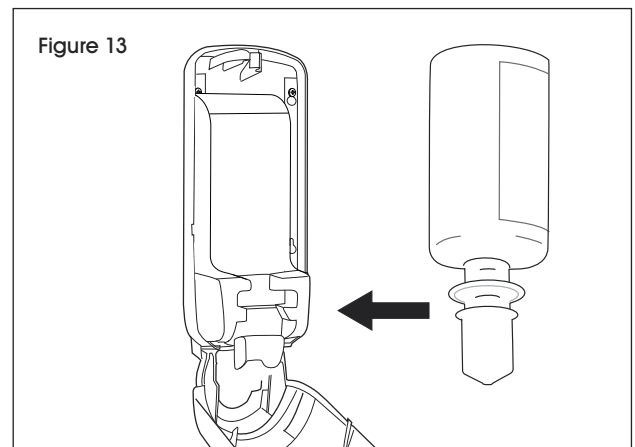

INSTRUCTIONS CONTINUED

INDICATOR LIGHTS

1. Light on front of dispenser will flash red when batteries are low and green when soap refill is low. (See Figure 15)

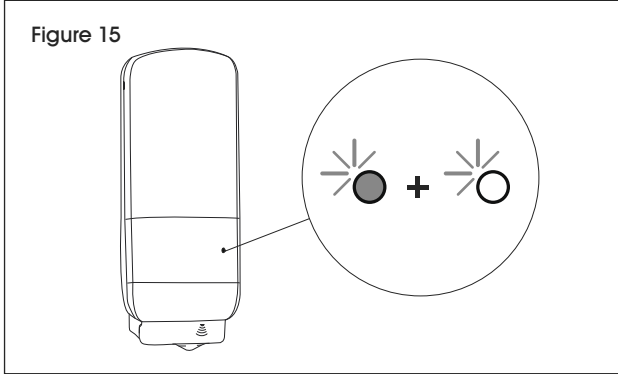

2. Solid light indicates dispenser is ready for use. (See Figure 16)

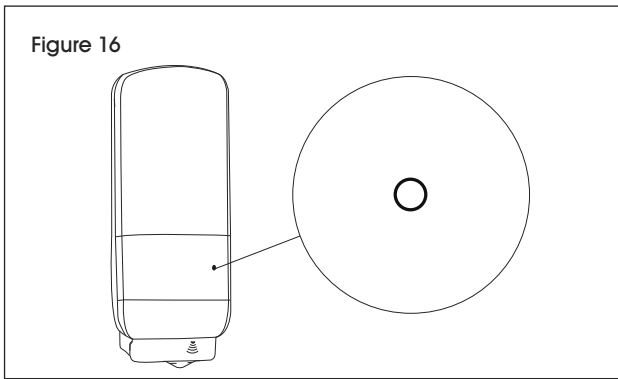

REFILLING

1. Light will flash green when soap refill is low. (See Figure 17)

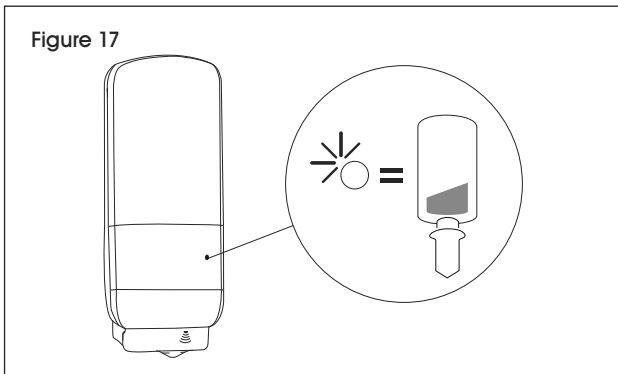

2. Open dispenser cover and remove empty refill. (See Figure 18)

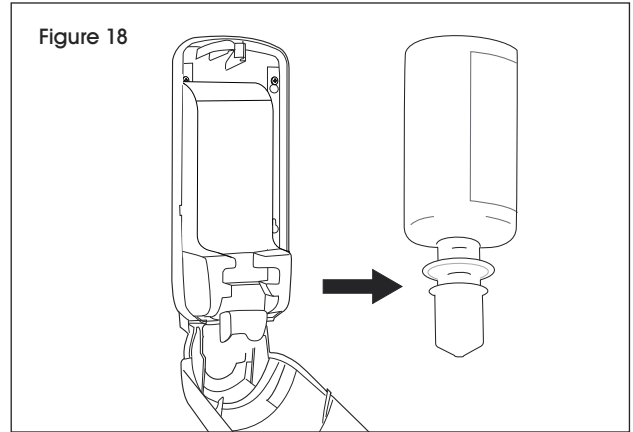

3. Twist nozzle in direction of arrows on replacement refill. (See Figure 19)

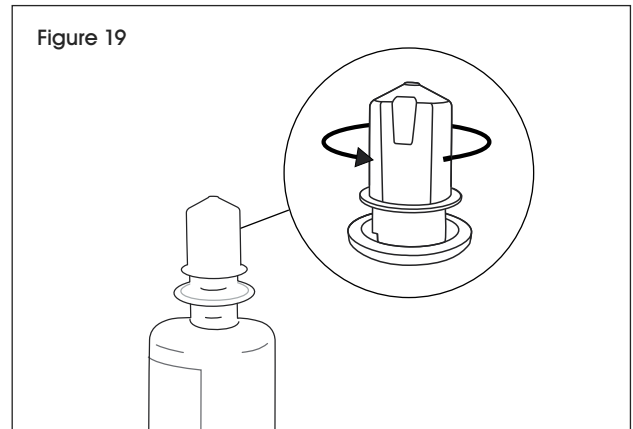

4. Flip replacement refill and load into cartridge. (See Figure 20)

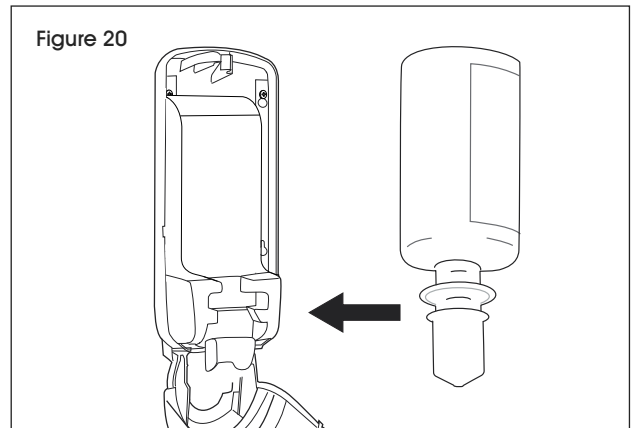

INSTRUCTIONS CONTINUED

5. Solid light indicates dispenser is ready for use. (See Figure 21)

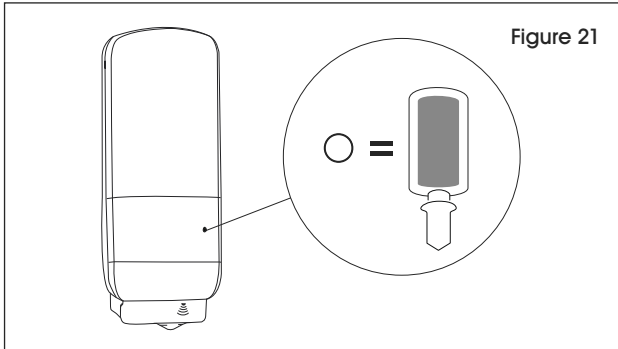

REPLACING BATTERIES

1. Light on front will flash red when batteries are low. Light will turn off when batteries are completely drained. (See Figure 22)

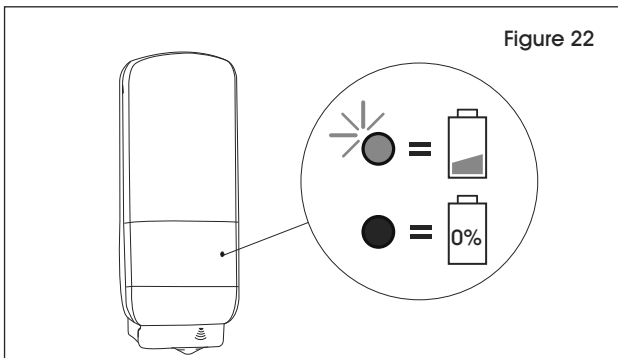

2. Open dispenser cover and push down on top of cartridge. Pull outward to remove. (See Figures 23-24)

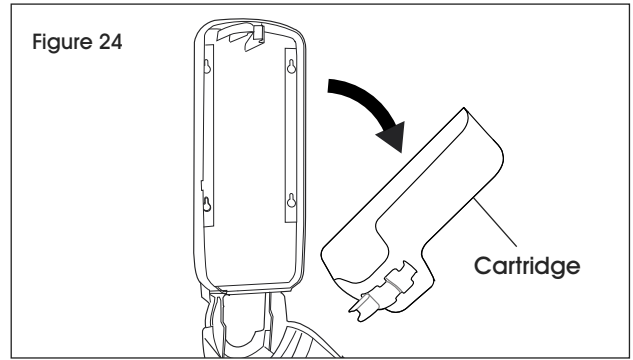
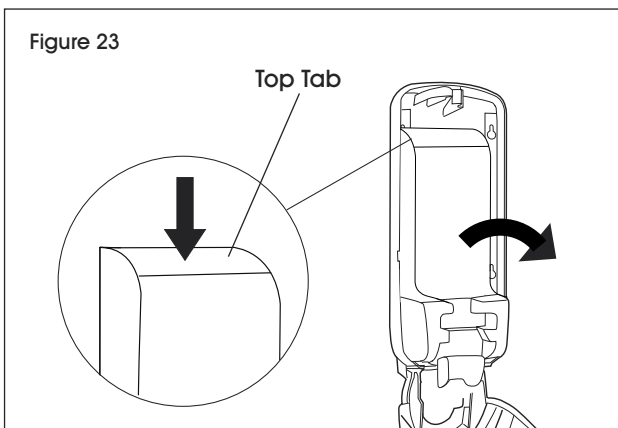

3. Remove old batteries. Replace with four new batteries. Click cartridge back into place. (See Figures 25-27)

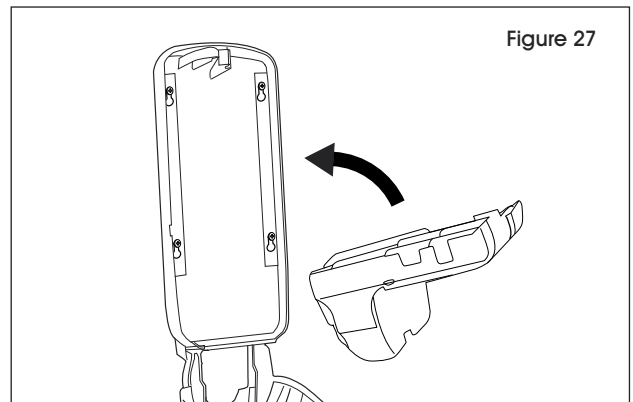
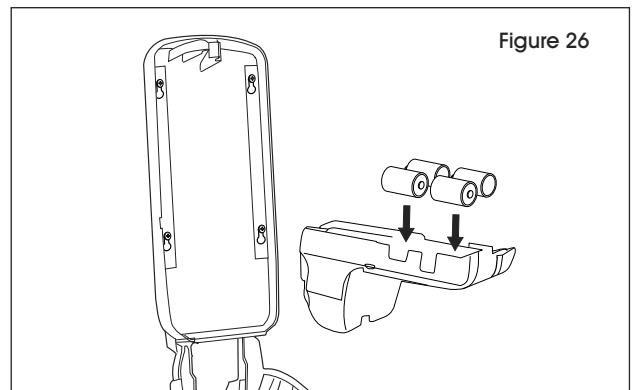
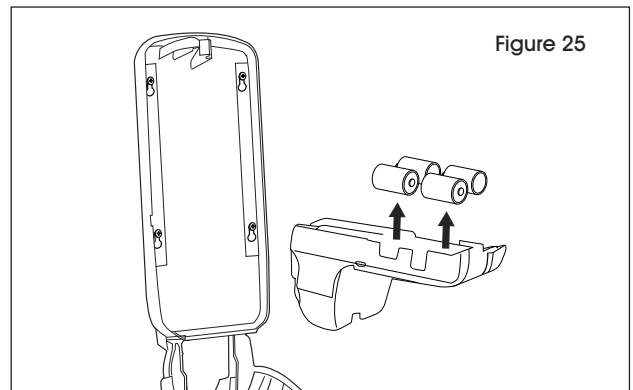

INSTRUCTIONS CONTINUED

4. Solid light indicates dispenser is ready for use.
(See Figure 28)

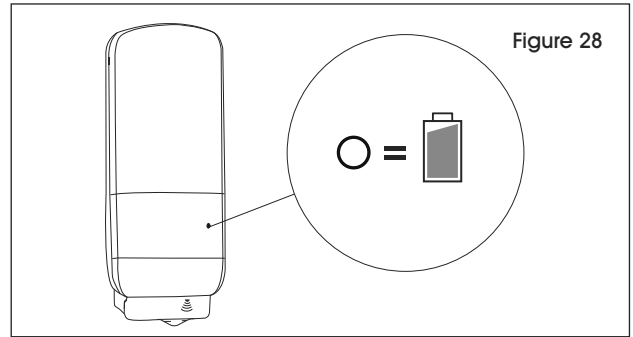

OPENING

USING KEYED OPTION

1. Insert key at position A.
(See Figure 29)
2. Turn and hold key clockwise to open dispenser.
(See Figure 30)

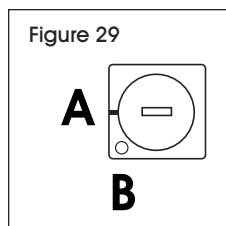

 **NOTE:** Release key back to position A after closing to lock dispenser.

USING NON-KEYED PUSH BUTTON OPTION

1. Insert key at position A and rotate counterclockwise to position B. (See Figure 31)
2. Remove key and push button to open dispenser.
(See Figure 32)

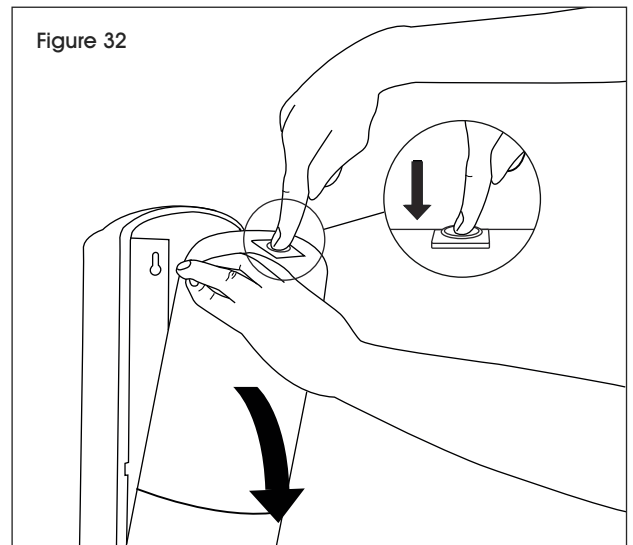
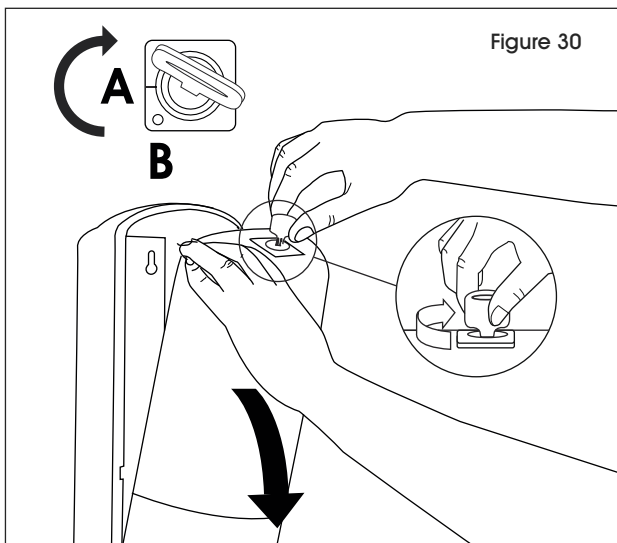
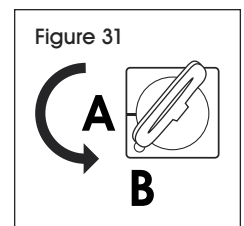

MAINTENANCE

Clean dispenser with mild detergent and soft cloth.

ULINE

1-800-295-5510
uline.com

ULINE H-5808

TORK® DESPACHADOR AUTOMÁTICO PARA JABÓN EN ESPUMA – PLÁSTICO

800-295-5510
uline.mx

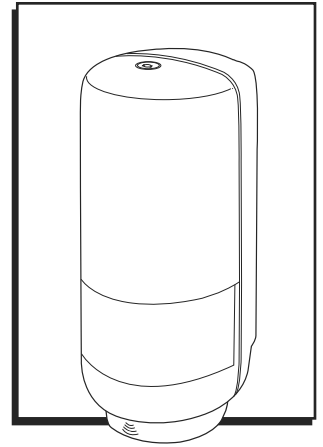

HERRAMIENTAS NECESARIAS



Taladro



Broca de 1/4"

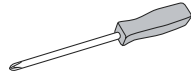

Desarmador de Cruz

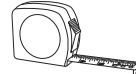

Cinta de Medir

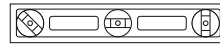

Nivel

PARTES

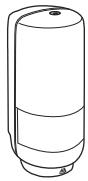

1 Despachador

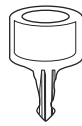

1 Llave



4 Baterías C-Cell
(no se incluyen)

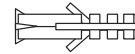

4 Taquetes
(no se incluyen)

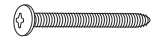

4 Tornillos
(no se incluyen)

SEGURIDAD

- No permita que los niños jueguen con el despachador.
- Las temperaturas ambiente mínima y máxima para un funcionamiento correcto son 0-50°C (32-122°F).
- El despachador no es apto para instalación en exteriores o en entornos húmedos. No es resistente al agua.
- El nivel de sonido de funcionamiento es menor a 70dBa.
- El producto dañado o defectuoso debe desecharse de inmediato para evitar lesiones.
- El producto debe desecharse conforme a las regulaciones aplicables.

INSTALACIÓN

 **NOTA:** Instale el despachador por lo menos a 15.2 cm (6") por encima del mostrador o lavabo.

1. Pegue la plantilla incluida con cinta adhesiva a la pared para usar como guía. Asegúrese de que la plantilla esté nivelada. (Vea Diagrama 1)

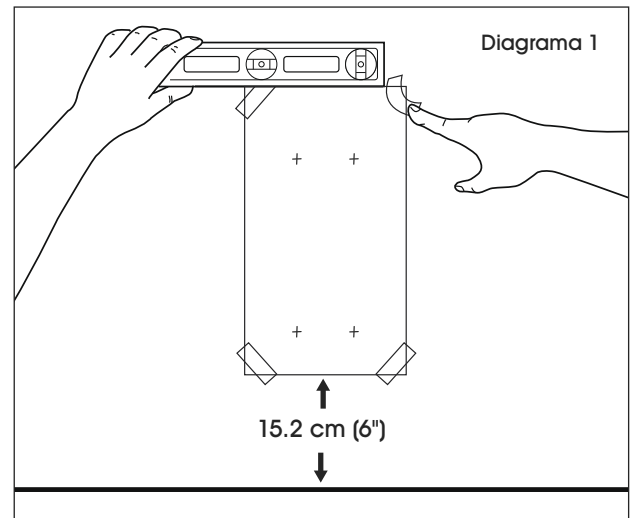

CONTINUACIÓN DE INSTALACIÓN

2. Perfore cuatro orificios usando la broca de 1/4" y retire la plantilla de la pared. (Vea Diagrama 2)

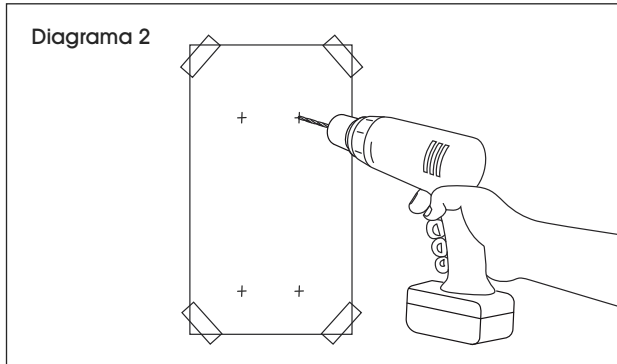

3. Inserte los taquetes y tornillos. (Vea Diagrama 3)

 **NOTA:** No apriete los tornillos completamente hasta el paso 7.

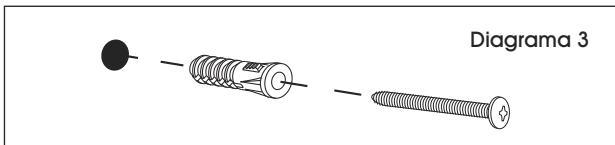

4. Abra el despachador y retire el cartucho presionando la parte de la pestaña superior y jálolo hacia afuera. (Vea Diagramas 4-5)

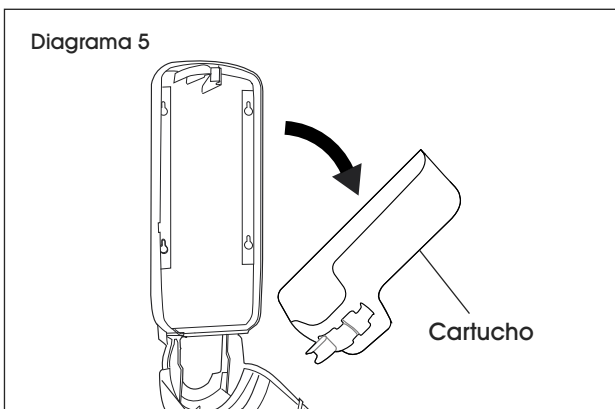
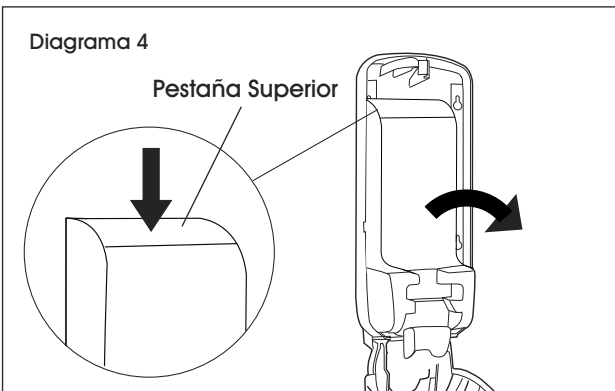

5. Sostenga el despachador contra la pared y alinee los orificios sobre los tornillos. (Vea Diagrama 6)

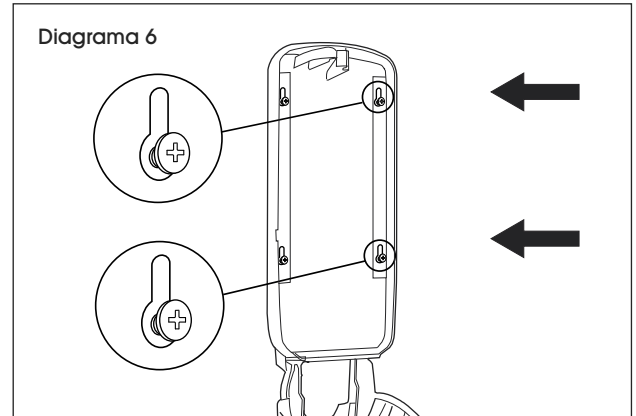

6. Baje el despachador encima de los tornillos. (Vea Diagrama 7)

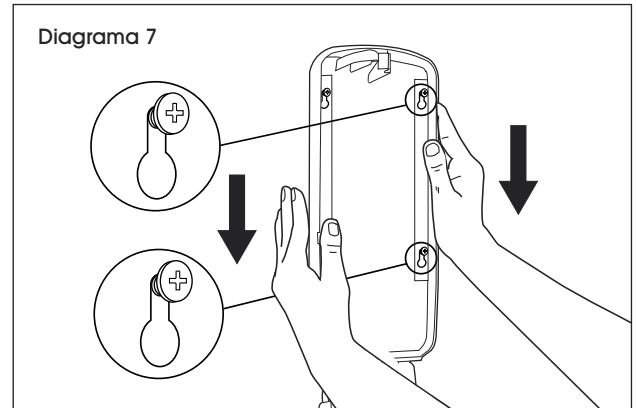

7. Apriételos. (Vea Diagrama 8)

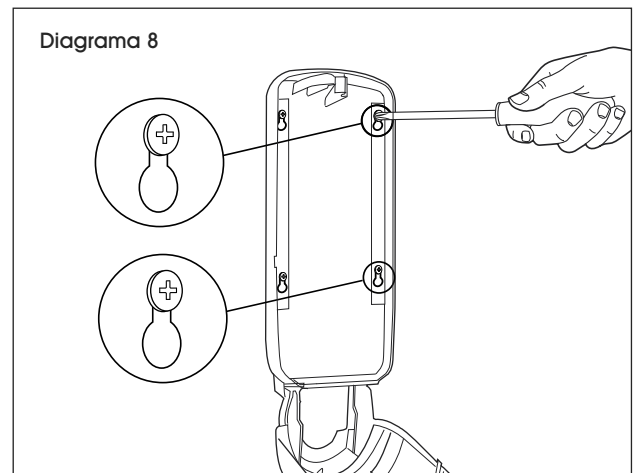

INSTRUCCIONES

CARGA

1. Inserte las cuatro baterías en la parte posterior del cartucho. (Vea Diagrama 9)

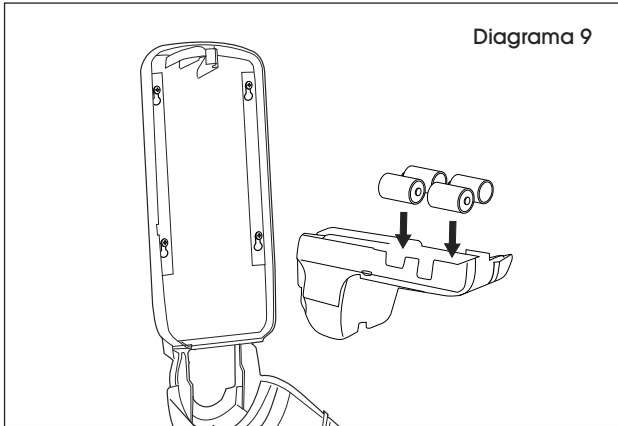

2. Vuelva a colocar el cartucho en la cubierta del despachador. Una vez que lo inserte correctamente, el cartucho debe hacer clic en su lugar. (Vea Diagramas 10-11)

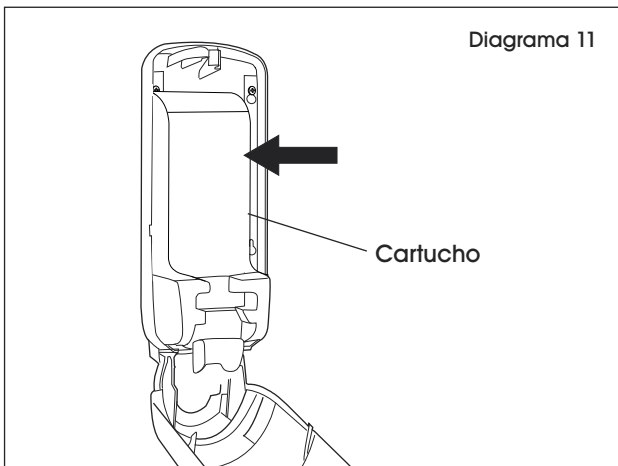
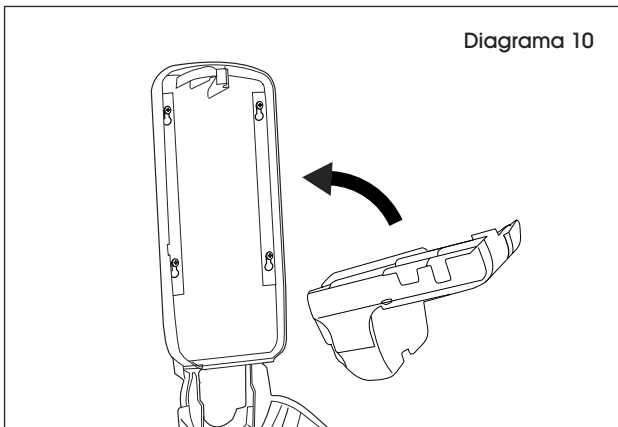

3. Antes de poner el repuesto, gire la boquilla en dirección de las flechas hasta que haga clic. (Vea Diagrama 12)

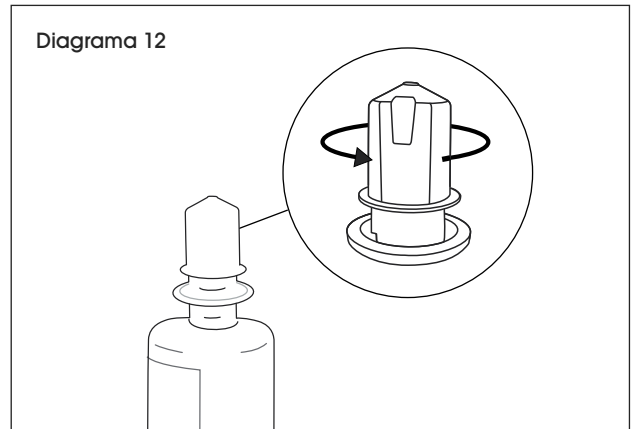

4. Voltee el repuesto cabeza abajo e insértelo dentro del cartucho con la boquilla hacia abajo. (Vea Diagramas 13-14)

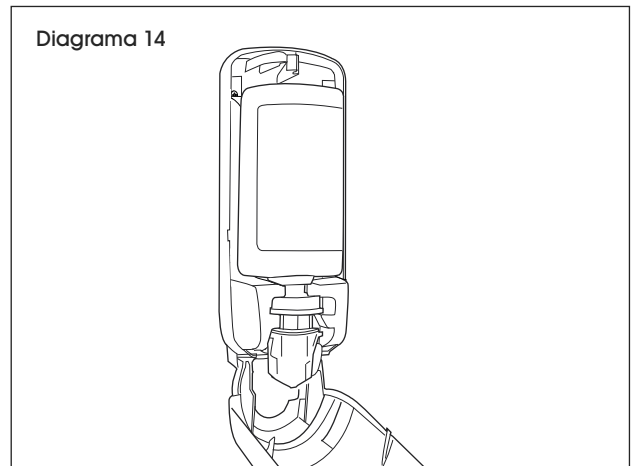
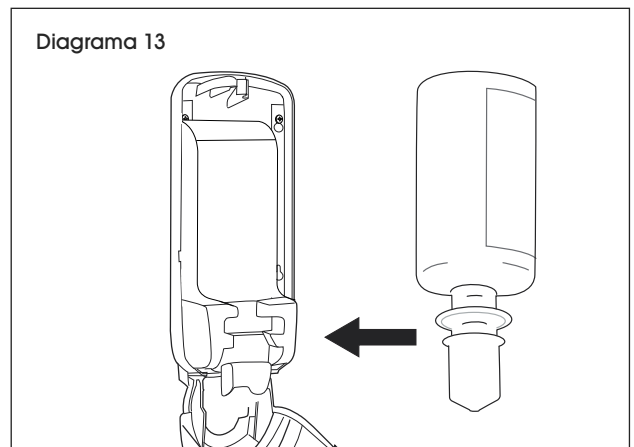

CONTINUACIÓN DE INSTRUCCIONES

LUCES INDICADORAS

1. La luz en el frente del despachador parpadeará en rojo cuando las baterías estén bajas y verde cuando el repuesto de jabón esté bajo. (Vea Diagrama 15)

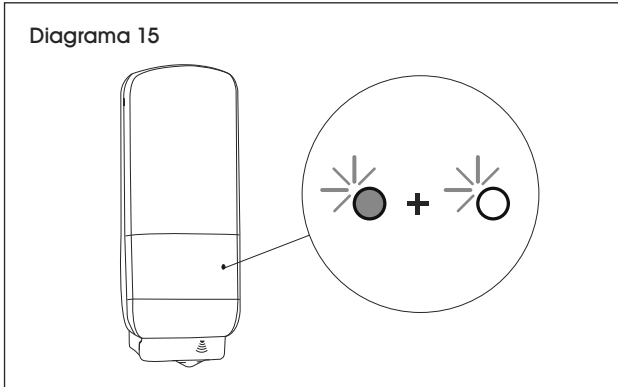

2. La luz sólida indica que el despachador está listo para usarse. (Vea Diagrama 16)

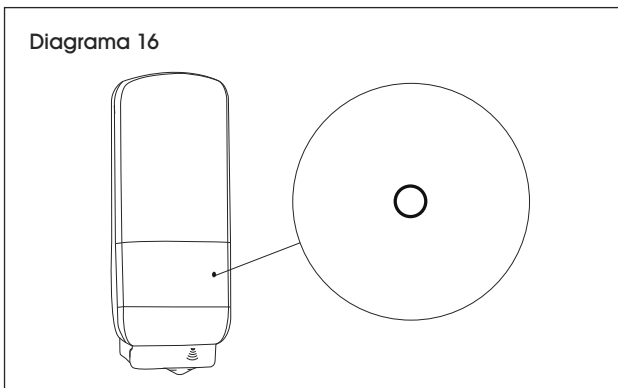

REPUESTO

1. La luz parpadeará en verde cuando el repuesto de jabón esté bajo. (Vea Diagrama 17)

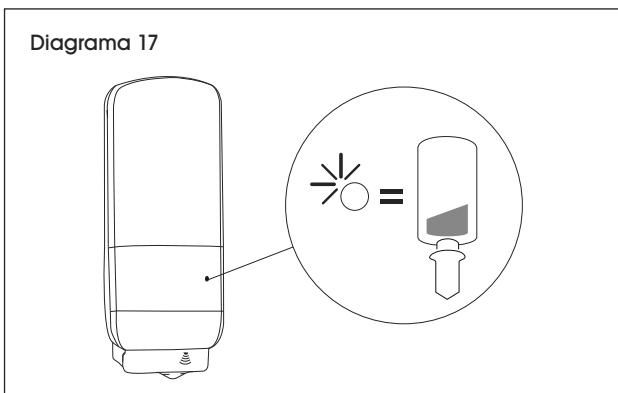

2. Abra la cubierta del despachador y retire el repuesto vacío. (Vea Diagrama 18)

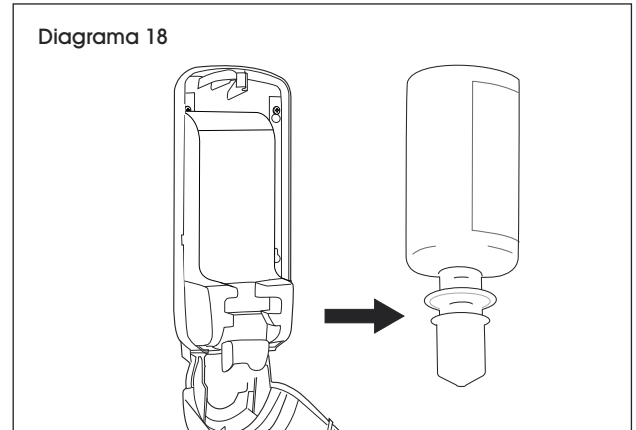

3. Gire la boquilla en dirección de las flechas marcadas en el repuesto. (Vea Diagrama 19)

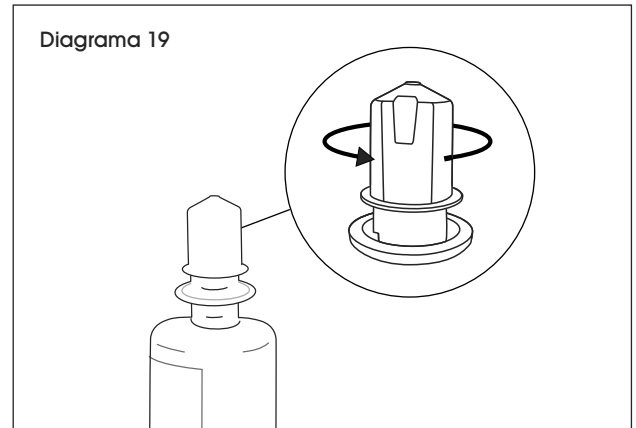

4. Voltee el repuesto e insértelo en el cartucho. (Vea Diagrama 20)

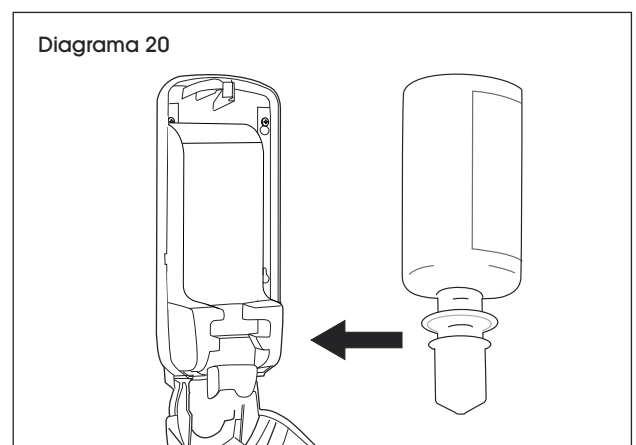

CONTINUACIÓN DE INSTRUCCIONES

5. La luz sólida indica que el despachador está listo para usarse. (Vea Diagrama 21)

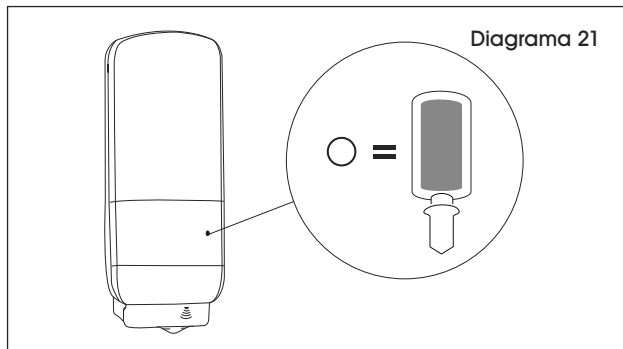

CAMBIAR LAS BATERÍAS

1. La luz del frente parpadeará en rojo cuando las baterías estén bajas. La luz se apagará cuando las baterías estén completamente agotadas. (Vea Diagrama 22)

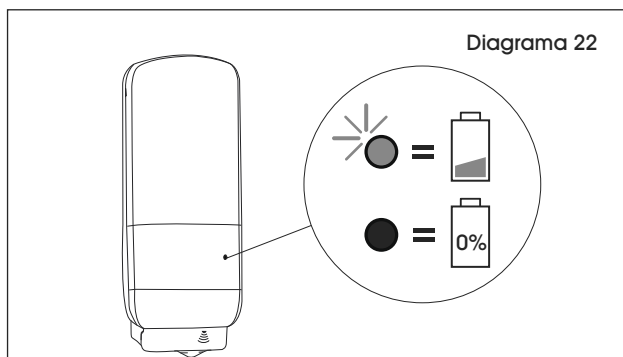

2. Abra la cubierta del despachador y presione la parte superior del cartucho. Jále hacia afuera para quitarlo. (Vea Diagramas 23-24)

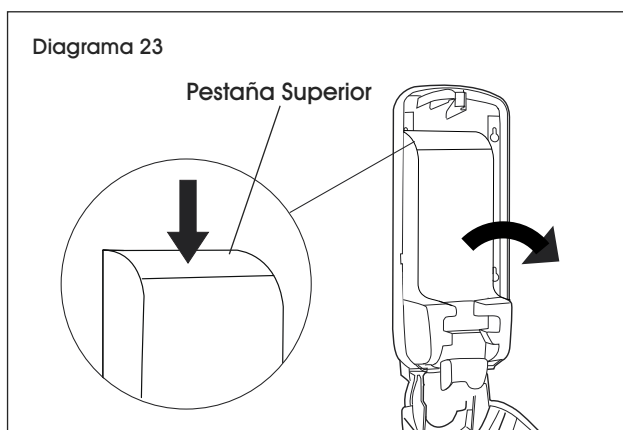

3. Retire las baterías viejas. Cámbielas por cuatro baterías nuevas. Coloque el cartucho de vuelta en su lugar hasta que haga clic. (Vea Diagramas 25-27)

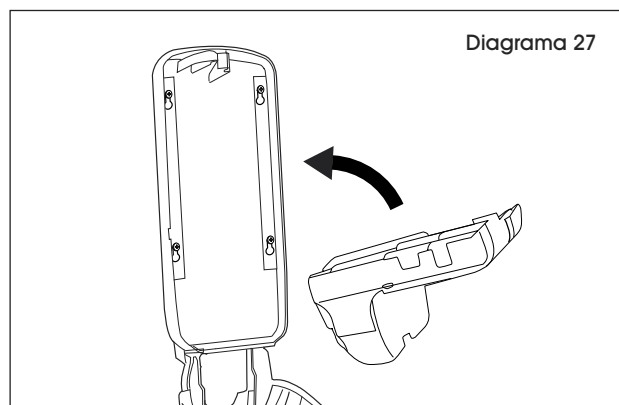
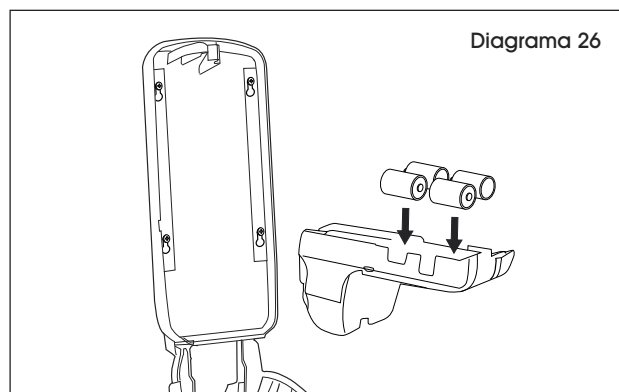
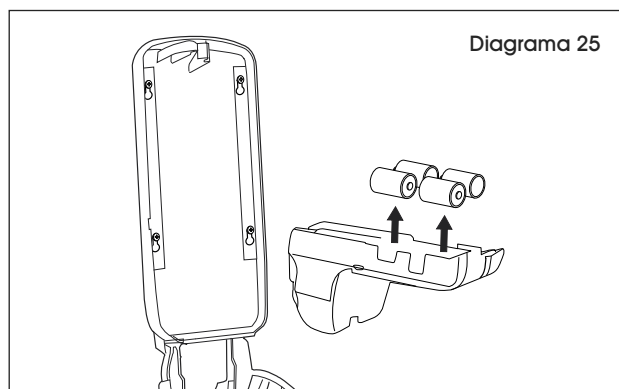
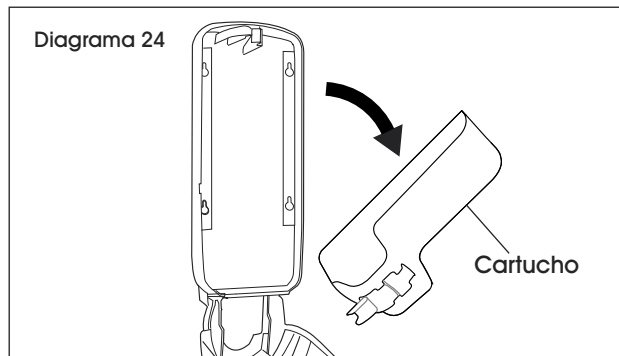

CONTINUACIÓN DE INSTRUCCIONES

- La luz sólida indica que el despachador está listo para usarse. (Vea Diagrama 28)

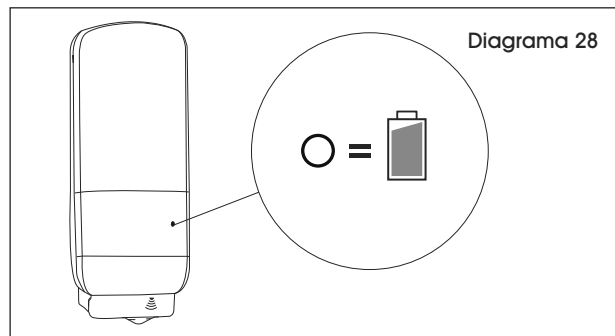

ABRIR

USAR LA OPCIÓN CON LLAVE

- Inserte la llave en la posición A. (Vea Diagrama 29)
- Para abrir el despachador, gire y mantenga la llave en el sentido de las manecillas del reloj. (Vea Diagrama 30)

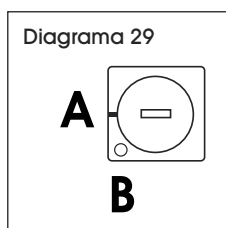

 **NOTA:** Después de cerrar el despachador con llave, regrésela a la posición A.

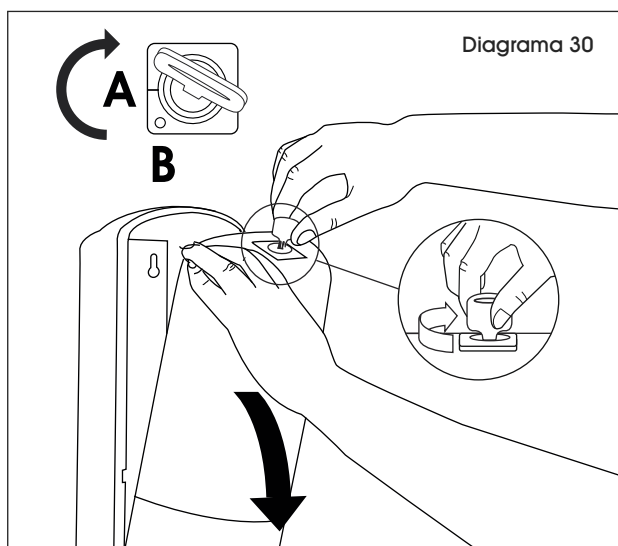

USAR LA OPCIÓN DE BOTÓN SIN LLAVE

- Inserte la llave en la posición A y gire en el sentido contrario a las manecillas del reloj hacia la posición B. (Vea Diagrama 31)
- Retire la llave y presione el botón para abrir el despachador. (Vea Diagrama 32)

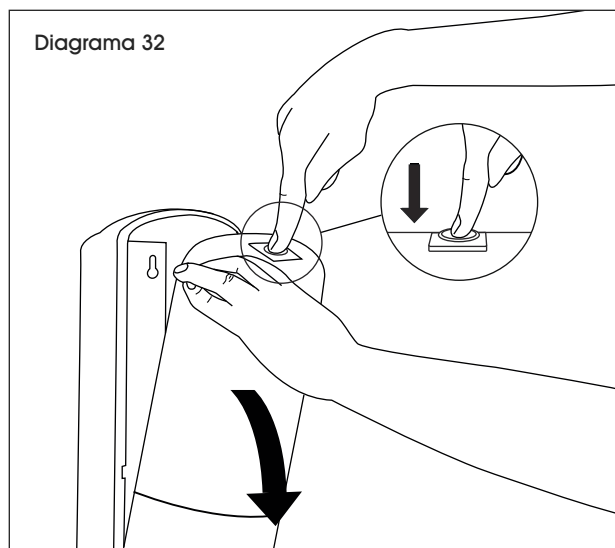
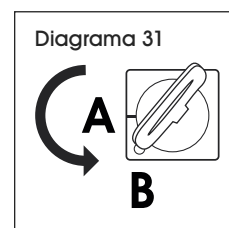

MANTENIMIENTO

Limpie el despachador con detergente suave y un paño suave.

ULINE

800-295-5510
uline.mx

ULINE H-5808

TORK^{MD} – DISTRIBUTEUR DE SAVON MOUSSANT AUTOMATIQUE EN PLASTIQUE

1-800-295-5510

uline.ca

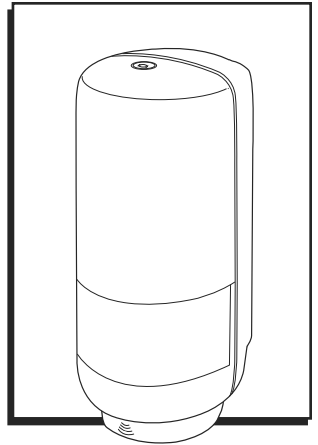

OUTILS REQUIS



Perceuse



Mèche de perceuse de 1/4 po

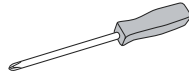

Tournevis cruciforme



Ruban à mesurer

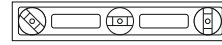

Niveau à bulle

PIÈCES

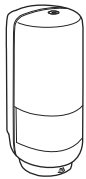

Distributeur x 1

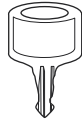

Clé x 1



Pile C x 4 (non inclus)

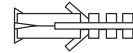

Ancrage mural x 4 (non inclus)



Vis x 4 (non inclus)

SÉCURITÉ

- Ne laissez pas les enfants jouer avec le distributeur.
- Les températures ambiantes minimales et maximales d'utilisation sont comprises entre 0 et 50 °C (32 et 122 °F).
- Le distributeur n'est pas adapté pour une installation à l'extérieur ou dans des endroits humides. Il n'est pas résistant à l'eau.
- Le niveau sonore lors du fonctionnement est en dessous de 70 dBA.
- Un produit défectueux ou endommagé doit être immédiatement mis au rebut pour éviter les blessures.
- L'élimination du produit doit être en conformité avec la réglementation en vigueur.

INSTALLATION



REMARQUE : Installez le distributeur à une hauteur d'au moins 15,2 cm (6 po) au-dessus de l'évier ou du comptoir.

1. Au moyen de ruban adhésif, collez au mur le gabarit de montage inclus servant de guide d'installation. Assurez-vous que le gabarit est correctement nivelé. (Voir Figure 1)

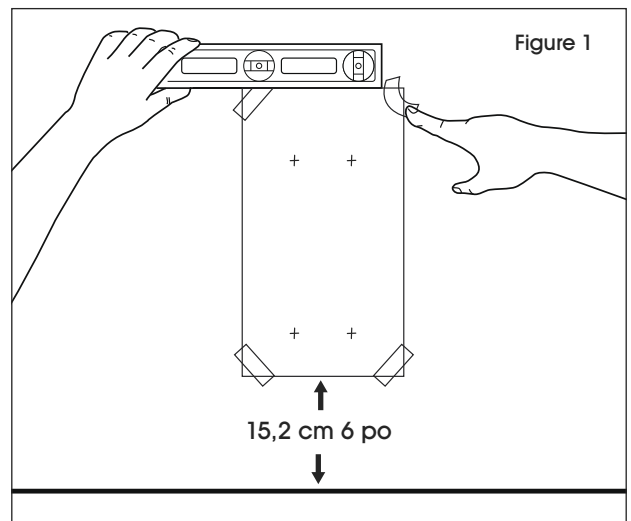
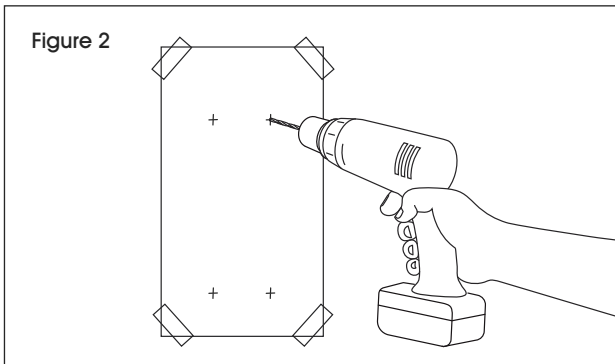

Figure 1

INSTALLATION SUITE

- Percez quatre trous à l'aide d'une mèche de perceuse de 1/4 po et retirez le gabarit du mur. (Voir Figure 2)



- Insérez les ancrages et les vis. (Voir Figure 3)

 **REMARQUE :** Ne serrez pas les vis à fond avant l'étape 7.

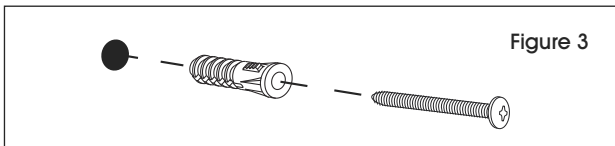

- Pour ouvrir le distributeur et retirer la cartouche, appuyez sur la partie du volet supérieur, puis tirez vers l'extérieur. (Voir Figures 4 et 5)

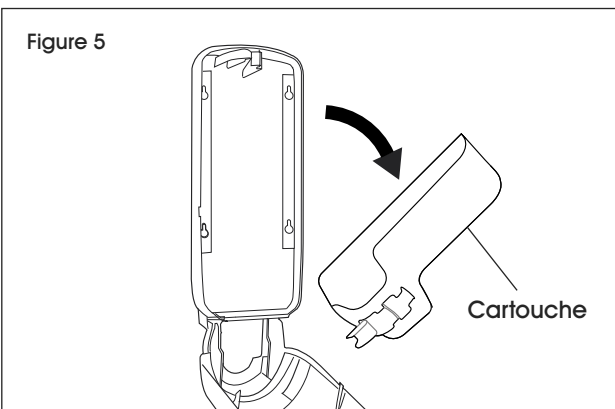
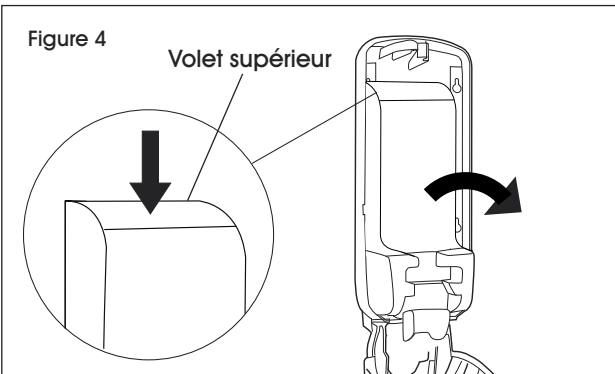

- Placez le distributeur contre le mur et alignez les trous sur les vis. (Voir Figure 6)

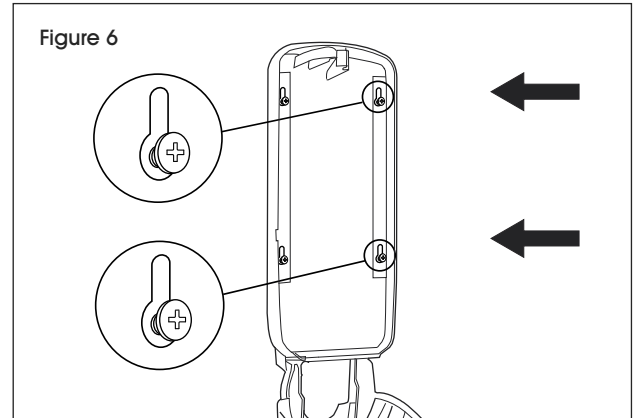

- Abaissez le distributeur pour qu'il repose sur les vis. (Voir Figure 7)

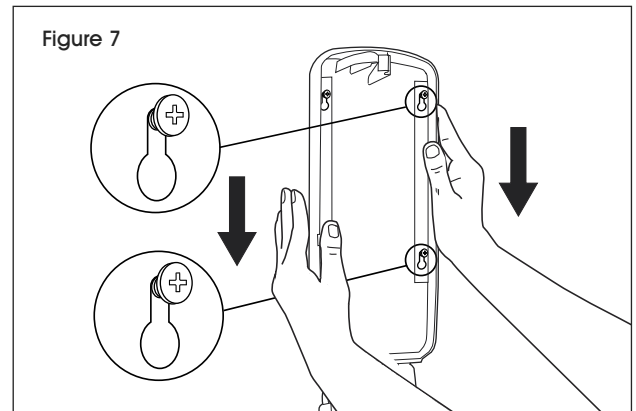

- Serrez les vis. (Voir Figure 8)

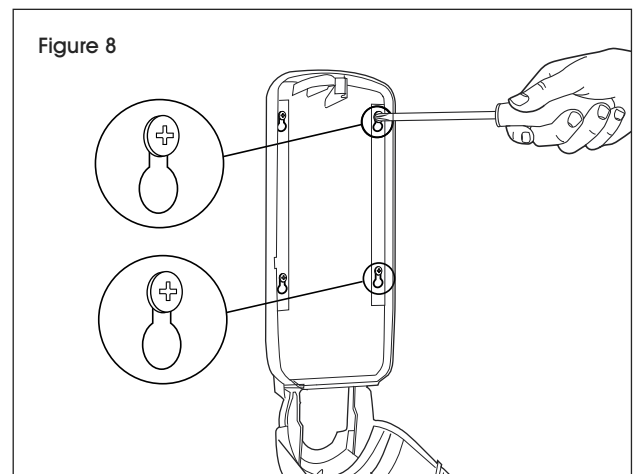

INSTRUCTIONS

CHARGEMENT

1. Placez les quatre piles à l'arrière de la cartouche. (Voir Figure 9)

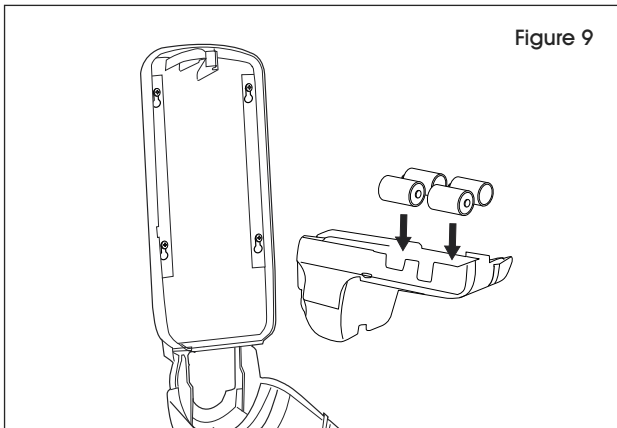

2. Remplacez la cartouche dans le boîtier du distributeur. Une fois bien insérée, la cartouche doit s'enclencher en place. (Voir Figures 10 et 11)

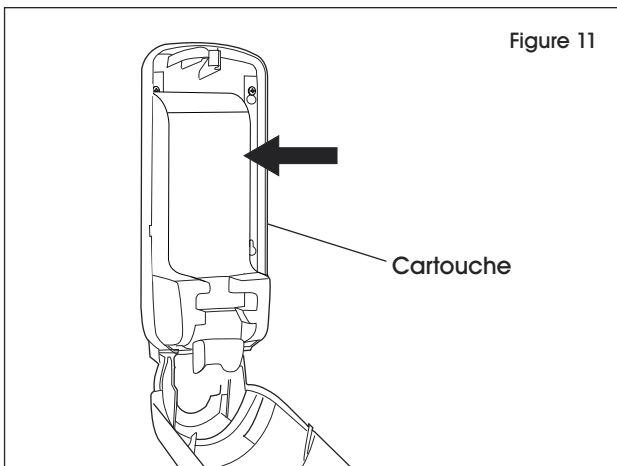
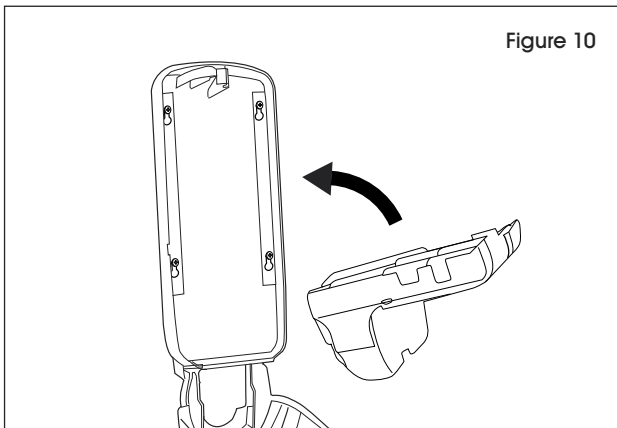

3. Avant d'installer la recharge, tournez l'embout dans le sens des flèches jusqu'à entendre un déclic. (Voir Figure 12)

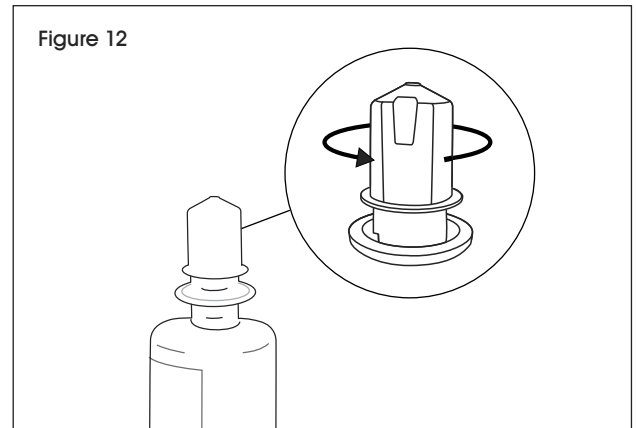

4. Positionnez la recharge à l'envers et logez-la dans la cartouche avec l'embout orienté vers le bas. (Voir Figures 13 et 14)

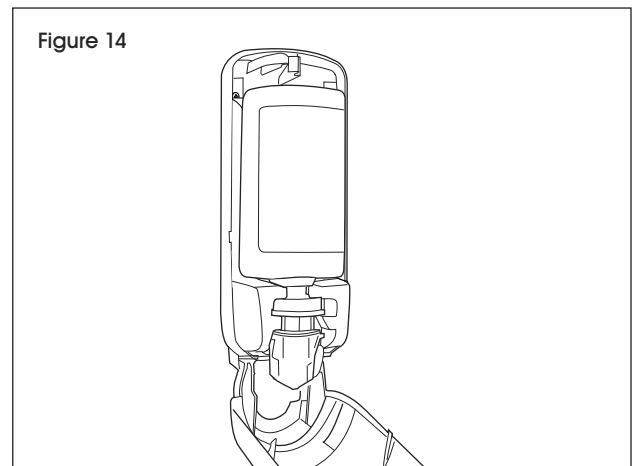
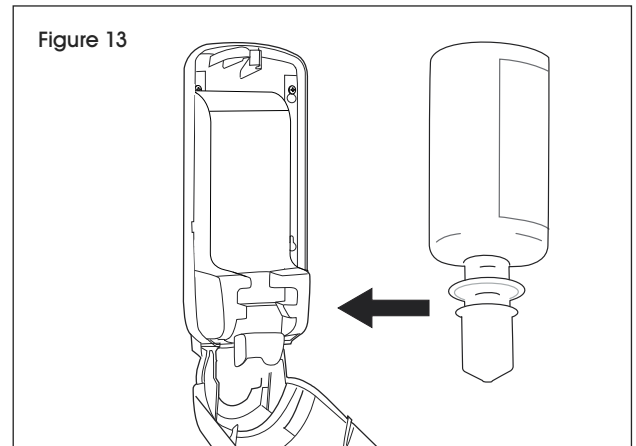

VOYANTS LUMINEUX

1. Le voyant à l'avant du distributeur clignote en rouge lorsque les piles sont faibles et en vert lorsque le niveau de savon est bas. (Voir Figure 15)

Figure 15

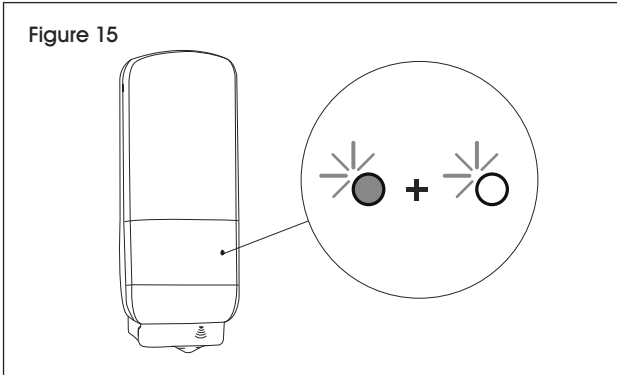

2. Un voyant fixe indique que le distributeur est prêt à l'emploi. (Voir Figure 16)

Figure 16

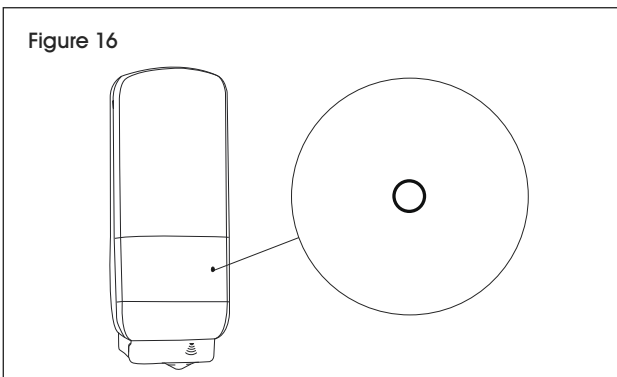

RECHARGEMENT

1. Le voyant clignote en vert lorsque le niveau de savon est bas. (Voir Figure 17)

Figure 17

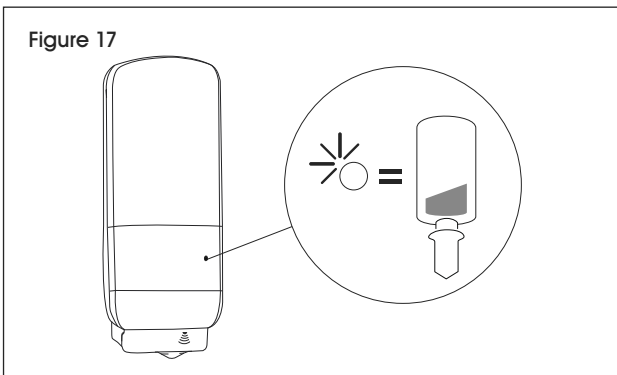

2. Ouvrez le couvercle du distributeur et retirez la recharge vide. (Voir Figure 18)

Figure 18

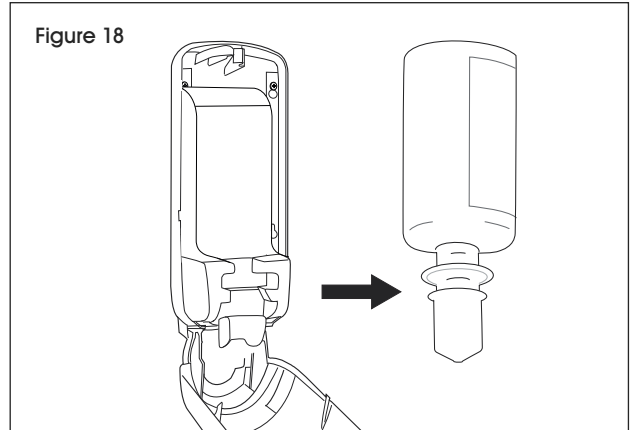

3. Tournez l'embout dans le sens des flèches de la recharge de remplacement. (Voir Figure 19)

Figure 19

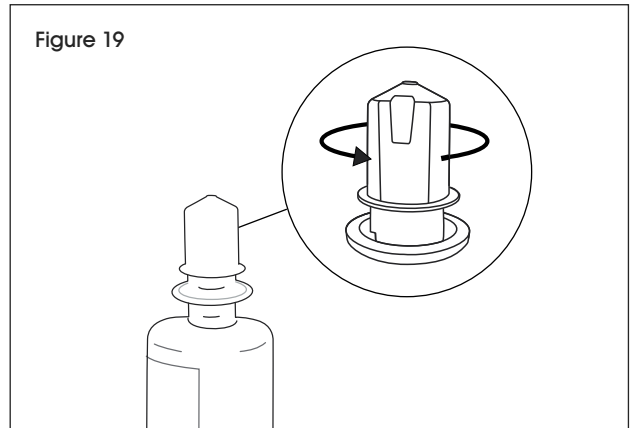

4. Positionnez la recharge à l'envers et logez-la dans la cartouche. (Voir Figure 20)

Figure 20

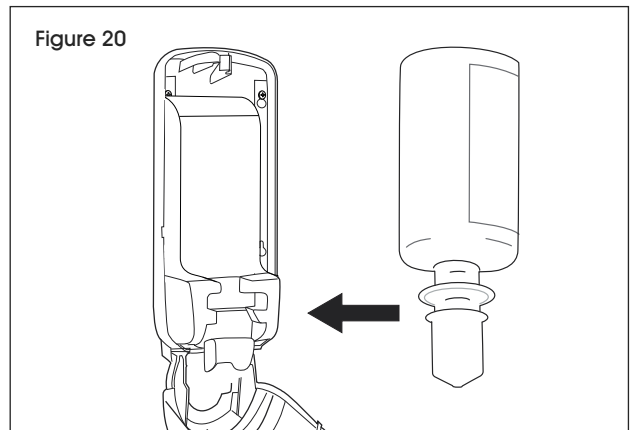

INSTRUCTIONS SUITE

5. Un voyant fixe indique que le distributeur est prêt à l'emploi. (Voir Figure 21)

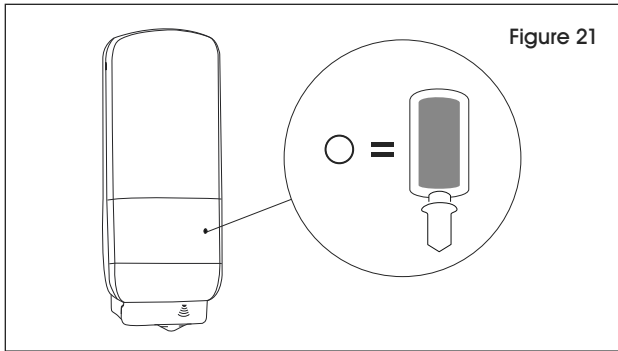

REPLACEMENT DES PILES

1. Le voyant à l'avant du distributeur clignote en rouge lorsque les piles sont faibles. Le voyant s'éteint lorsque les piles sont complètement usées. (Voir Figure 22)

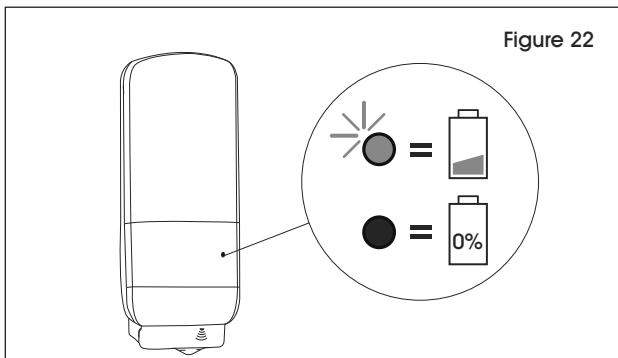

2. Ouvrez le couvercle du distributeur et appuyez sur le dessus de la cartouche. Tirez vers l'extérieur pour la retirer. (Voir Figures 23 et 24)

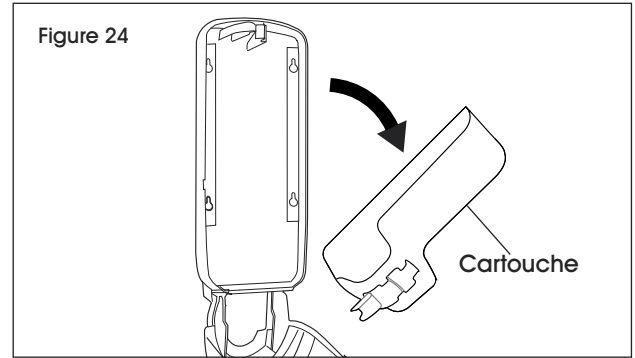
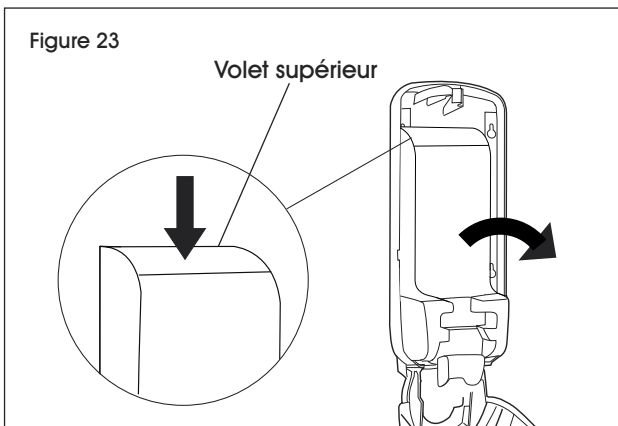

3. Enlevez les piles usées. Placez quatre nouvelles piles. Réenclenchez la cartouche à sa place. (Voir Figures 25 à 27)

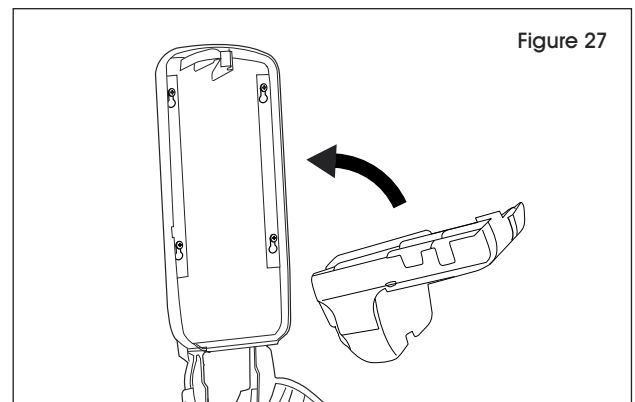
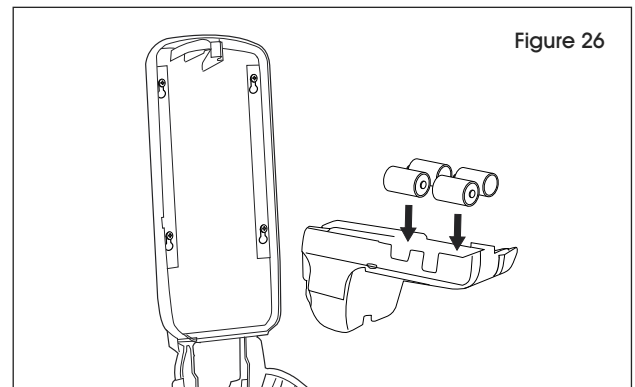
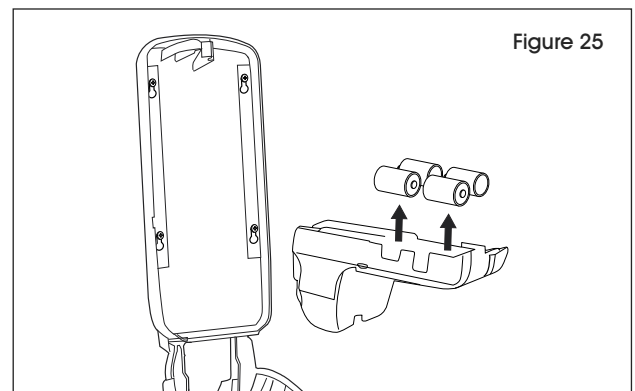

INSTRUCTIONS SUITE

4. Un voyant fixe indique que le distributeur est prêt à l'emploi. (Voir Figure 28)

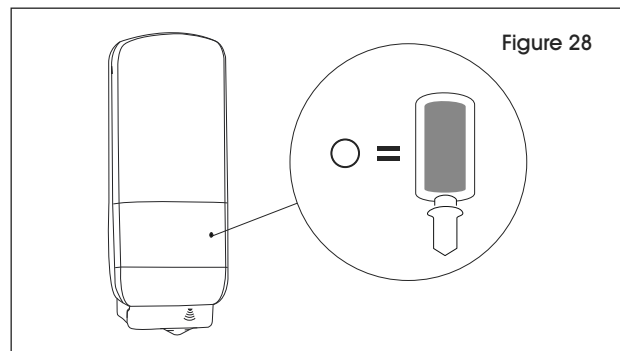

OUVERTURE DU DISTRIBUTEUR

OUVRIR À L'AIDE D'UNE CLÉ

1. Insérez la clé en position A. (Voir Figure 29)
2. Pour ouvrir le distributeur, tournez et maintenez la clé dans le sens horaire. (Voir Figure 30)

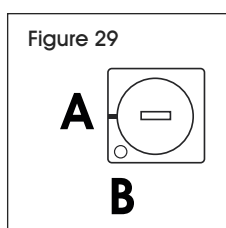

OUVRIR À L'AIDE D'UN BOUTON-POUSOIR SANS CLÉ

1. Insérez la clé en position A et tournez-la dans le sens antihoraire jusqu'à ce qu'elle atteigne la position B. (Voir Figure 31)
2. Retirez la clé et appuyez sur le bouton-pousoir pour ouvrir le distributeur. (Voir Figure 32)

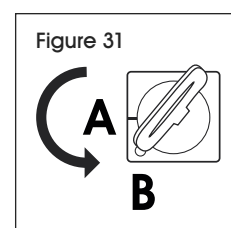

 **REMARQUE :** Pour verrouiller le distributeur après l'avoir fermé, relâchez la clé pour qu'elle reprenne la position A.

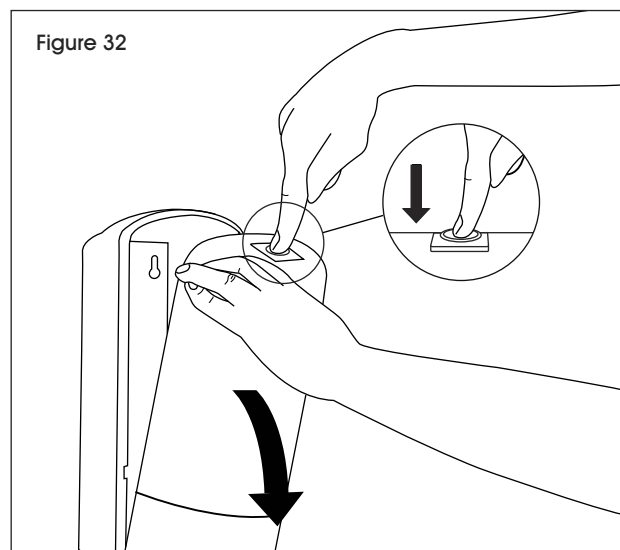
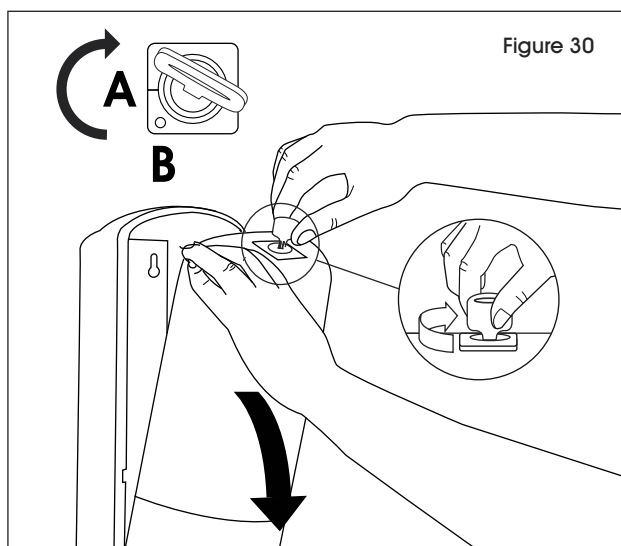

ENTRETIEN

Nettoyez le distributeur avec un détergent doux et un chiffon non abrasif.

ULINE

1-800-295-5510
uline.ca