

ULINE H-5826, H-5919
H-5920
DRY ERASE CALENDAR

1-800-295-5510
uline.com

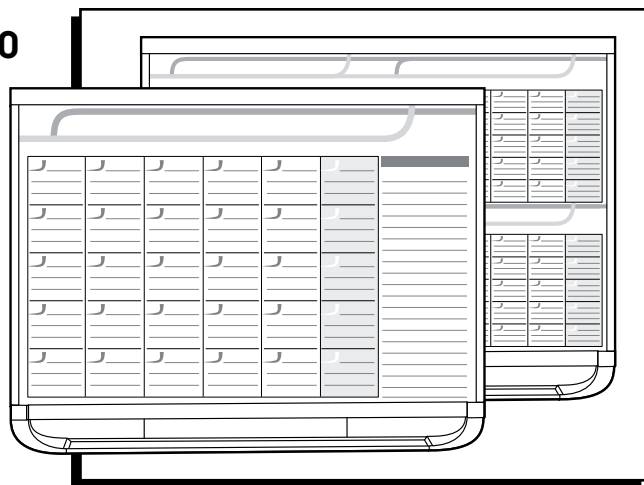

TOOLS NEEDED

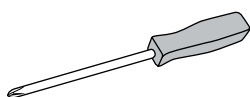

Phillips Screwdriver

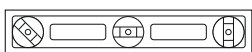

Level



Drill

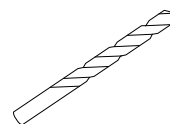

1/4" Drill Bit

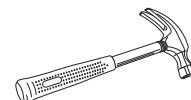

Hammer

PARTS

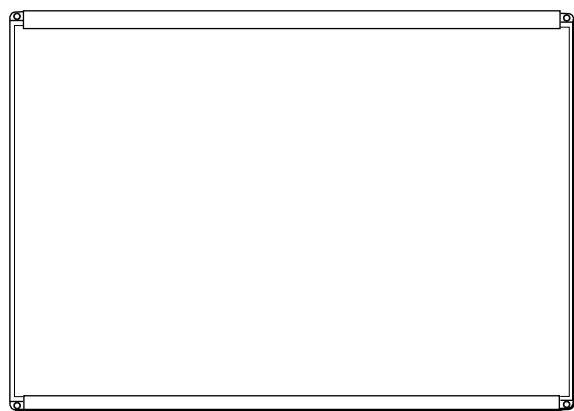

Board x 1

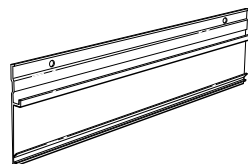

Installation Shelf
x 1

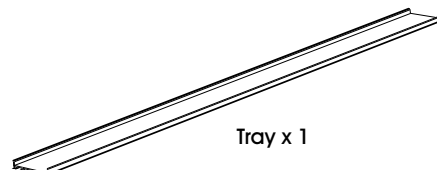

Tray x 1

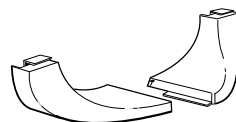

Tray End Cap
x 2

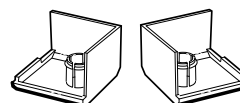

Corner Cap
x 4



Drywall
Anchor
x 6

#10 Screw
x 6

MOUNTING

1. Place the installation shelf flush against the wall. Ensure it is level and mark the installation holes. (See Figure 1)

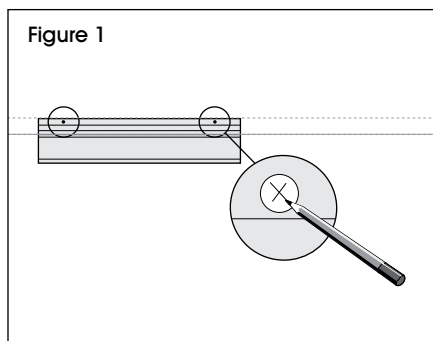

2. Remove the installation shelf and drill holes into the wall at marked locations. Insert wall anchors. (See Figure 2)

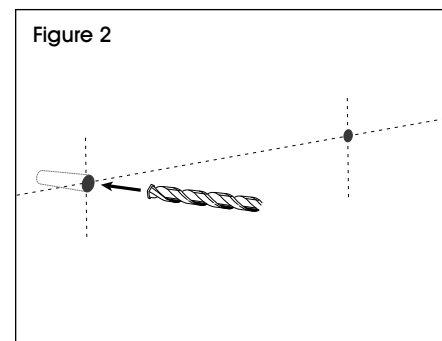

MOUNTING

3. Align installation shelf with holes and secure with two #10 screws. (See Figure 3)

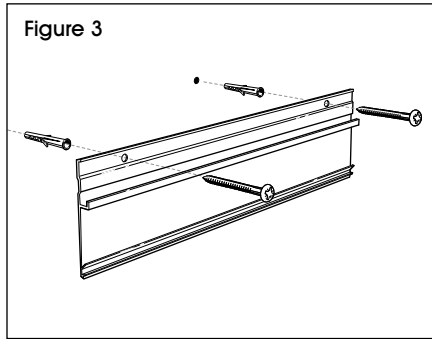

4. Place the board on top of the shelf and flush against the wall. Mark each installation point on the wall through the exposed corners. (See Figure 4)

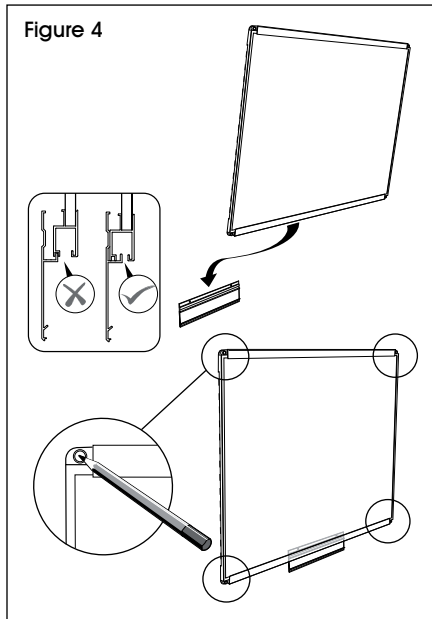

5. Remove the board and drill the installation points into the wall. Insert wall anchors. (See Figure 5)

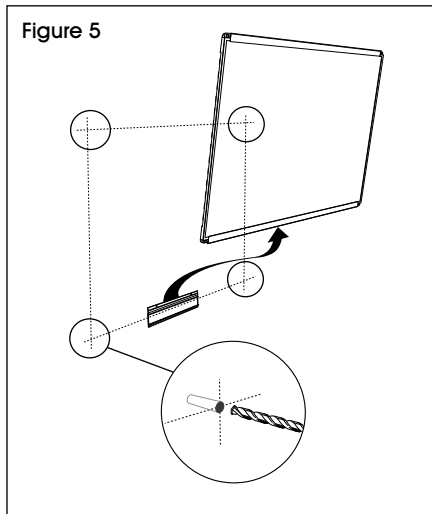

6. Place the board back on the shelf. Secure with four #10 screws. (See Figure 6)

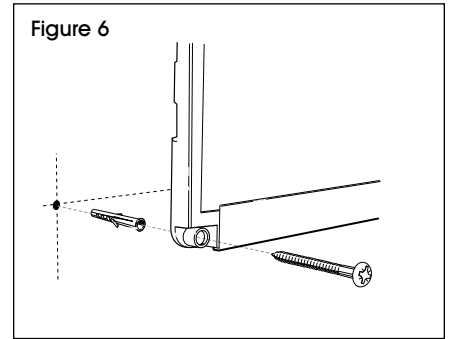

7. Insert marker tray at an angle onto the installation shelf. (See Figure 7)

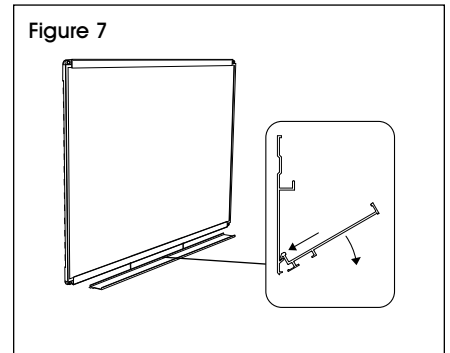

8. Place tray end caps on each end of the tray. (See Figure 8)

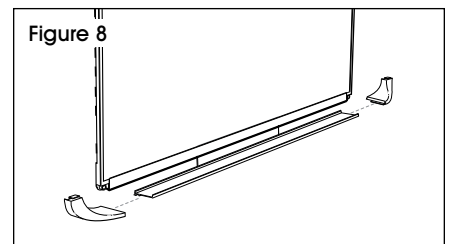

9. Place the corner caps on the board. (See Figure 9)

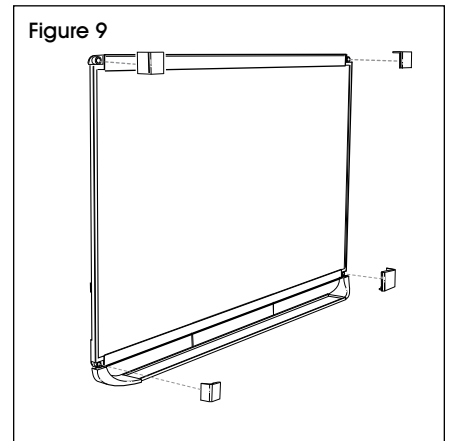

MAINTENANCE

- Clean board prior to first use with mild soap and water (do not use abrasive cleaners). Rinse and dry thoroughly with a soft cloth.
- Use only dry erase markers. Other markers may permanently damage the writing surface. For best erasing results, replace markers at least once a year.
- Use a clean eraser to remove dry erase ink from the board surface. Occasionally, use dry erase board cleaner to remove grease, dirt and dry erase ink residue that may build up on the board surface.
- Avoid leaving marks on the board surface for prolonged periods. Dry erase ink may become difficult to erase over time.
- Do not use adhesive tape on board surface.

ULINE

1-800-295-5510
uline.com



H-5826, H-5919
H-5920

PIZARRÓN BLANCO DE CALENDARIO

800-295-5510
uline.mx

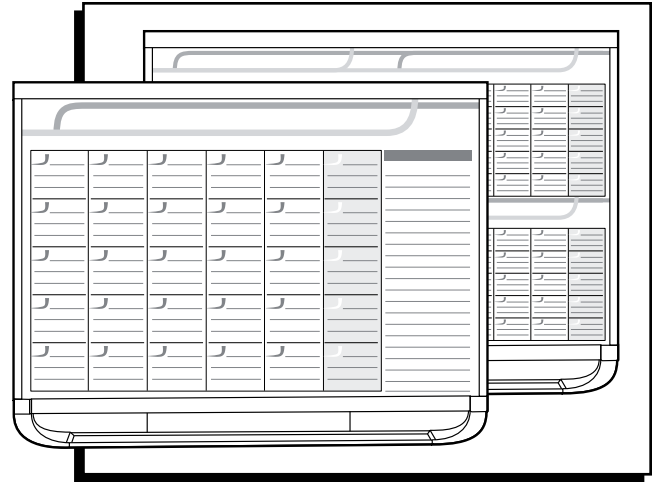

HERRAMIENTAS NECESARIAS

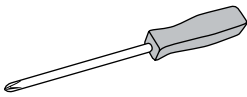

Desarmador de Cruz

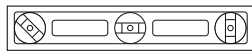

Nivel



Taladro

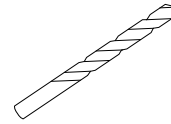

Broca de 1/4"

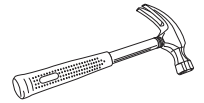

Martillo

PARTES

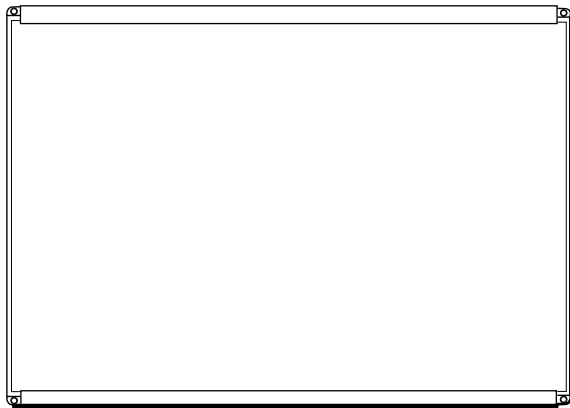

1 Pizarrón

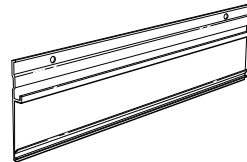

1 Repisa de Instalación

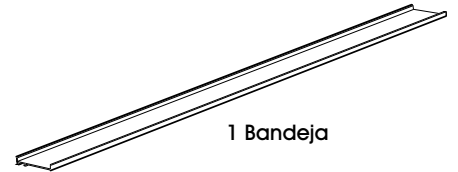

1 Bandeja

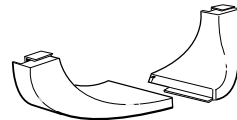

2 Tapas para Extremos de Bandeja

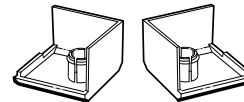

4 Tapas para Esquinas



6 Taquetes para Paneles de Yeso #10

INSTALACIÓN

1. Coloque la repisa de instalación a ras de la pared. Asegúrese que esté nivelada y marque los orificios de instalación. (Vea Diagrama 1)

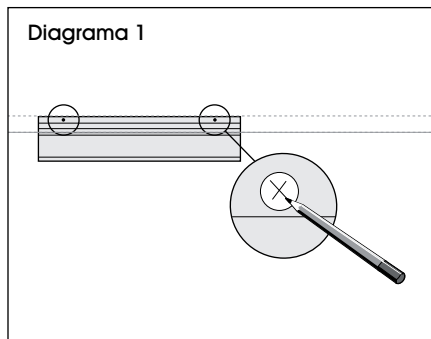

2. Retire la bandeja de instalación y taladre orificios en la pared sobre las ubicaciones que marcó. Inserte los taquetes. (Vea Diagrama 2)

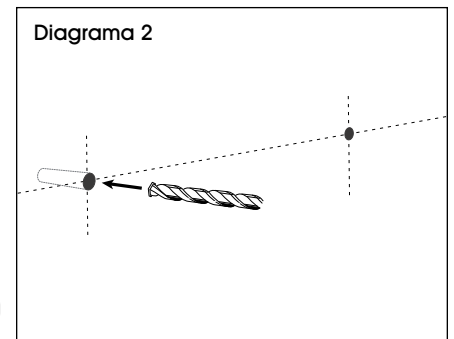

CONTINUACIÓN DE INSTALACIÓN

3. Alinee la repisa de instalación con los orificios y asegúrelos con dos tornillos #10. (Vea Diagrama 3)

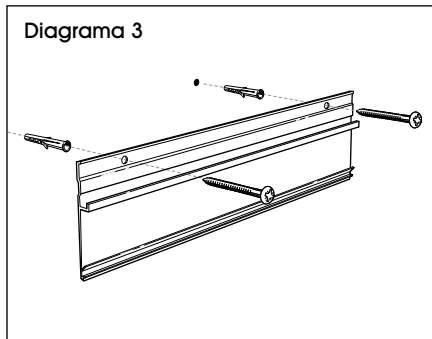

4. Coloque el pizarrón encima de la repisa y a ras de la pared. Marque cada punto de instalación en la pared sobre las esquinas expuestas. (Vea Diagrama 4)

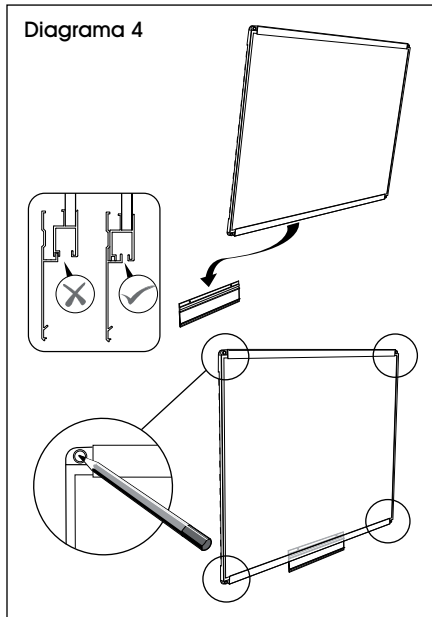

5. Retire el pizarrón y perfore los puntos de instalación en la pared. Inserte los taquetes. (Vea Diagrama 5)

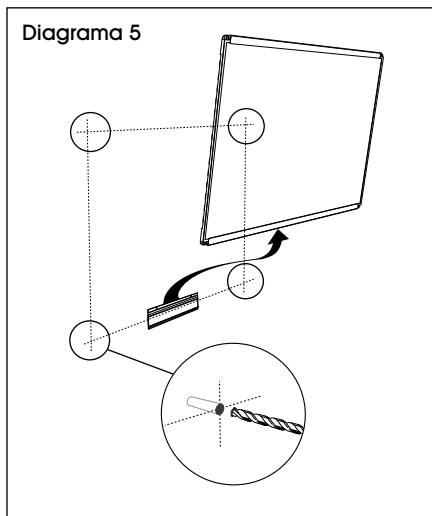

6. Coloque el pizarrón en la repisa. Asegúrelo con cuatro tornillos #10. (Vea Diagrama 6)

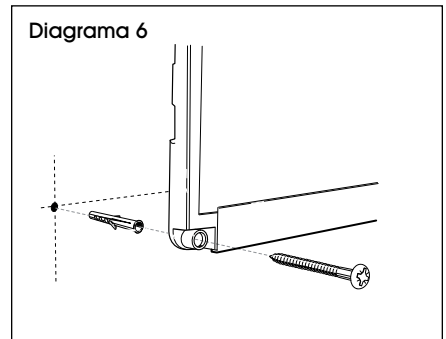

7. Coloque la bandeja para marcadores en ángulo en la repisa de instalación. (Vea Diagrama 7)

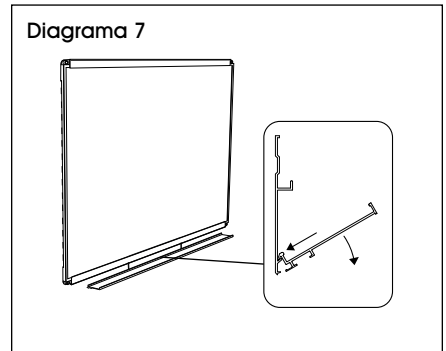

8. Coloque las tapas en cada extremo de la bandeja. (Vea Diagrama 8)

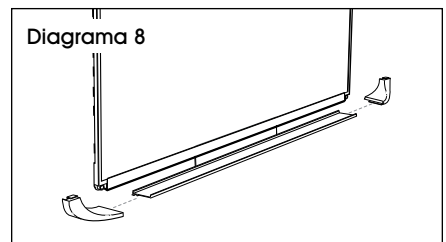

9. Coloque las tapas para esquinas en el pizarrón. (Vea Diagrama 9)

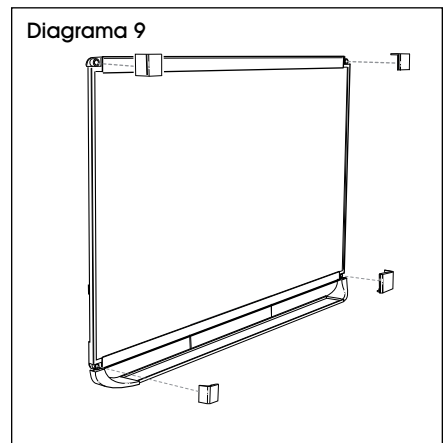

MANTENIMIENTO

- Limpie el pizarrón antes del primer uso con jabón suave y agua (no use limpiadores abrasivos). Enjuague y seque por completo con un trapo suave.
- Utilice solamente marcadores para pizarrón blanco. Otros marcadores pueden dañar permanentemente la superficie de escritura. Para mejores resultados al borrar, reemplace los marcadores al menos una vez al año.
- Utilice un borrador limpio para remover la tinta de los plumones de la superficie de escritura. Ocasionalmente, utilice un limpiador para pizarrón blanco para remover los residuos de grasa, tierra y tinta que puedan acumularse en la superficie del pizarrón.
- Evite dejar marcas en la superficie del pizarrón por periodos prolongados de tiempo. La tinta de los plumones para pizarrón blanco puede ser difícil de remover con el tiempo.
- No utilice cinta adhesiva en la superficie del pizarrón.

ULINE

800-295-5510
uline.mx

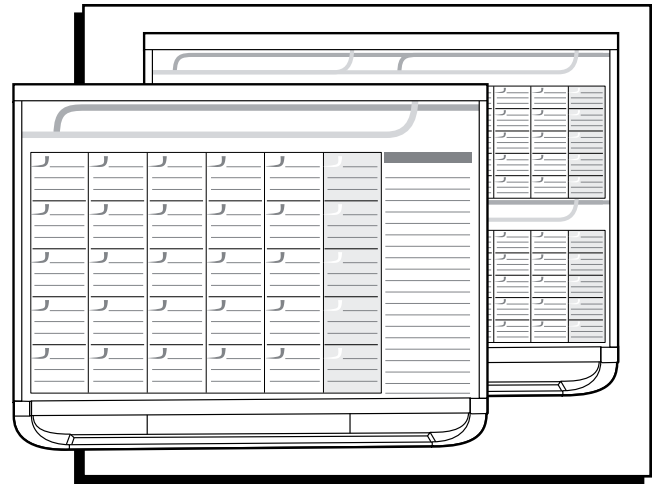

OUTILS REQUIS

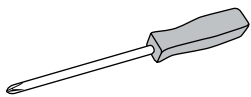

Tournevis cruciforme

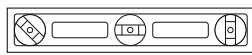

Niveau à bulle



Perceuse

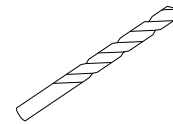

Mèche de perceuse
de 1/4 po

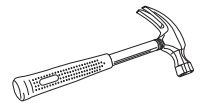

Marteau

PIÈCES



Tableau x 1



Tablette d'installation
x 1

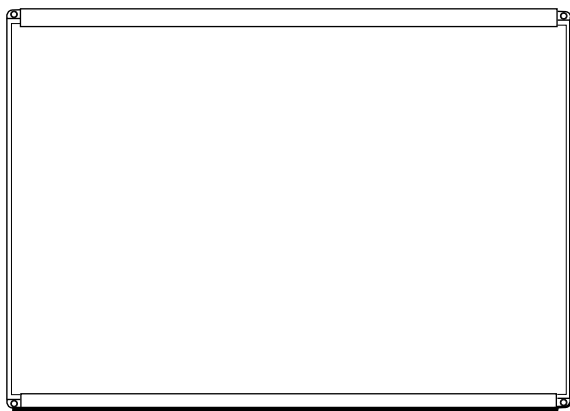
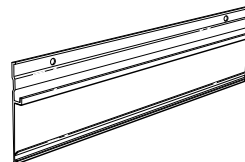
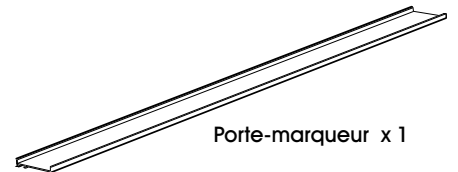

Porte-marqueur x 1

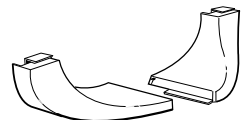

Embout du porte-marqueur
x 2

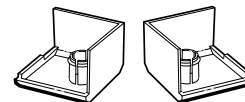

Couvre-coin
x 4

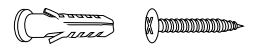

Ancrage pour
cloison sèche
x 6
Vis n° 10
x 6

INSTALLATION

1. Placez la tablette d'installation à plat contre le mur. Assurez-vous de la niveler et marquez ensuite les repères pour les trous d'installation. (Voir Figure 1)

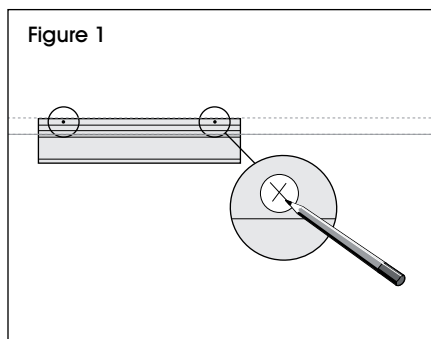

2. Retirez la tablette d'installation et percez les trous aux repères marqués sur le mur. Insérez les ancrages muraux. (Voir Figure 2)

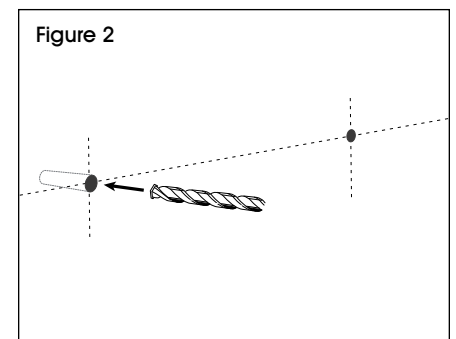

INSTALLATION SUITE

3. Aligned la tablette d'installation sur les trous et fixez-la avec deux vis n° 10. (Voir Figure 3)

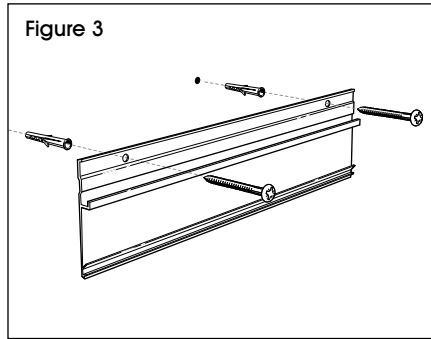

4. Placez le tableau à plat contre le mur sur la tablette d'installation. Marquez chaque repère de fixation sur le mur à travers les coins découverts. (Voir Figure 4)

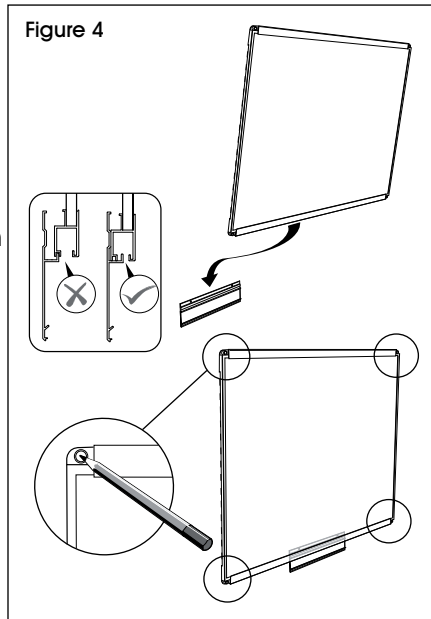

5. Retirez le tableau et percez les trous sur les repères de fixation. Insérez les ancrages muraux. (Voir Figure 5)

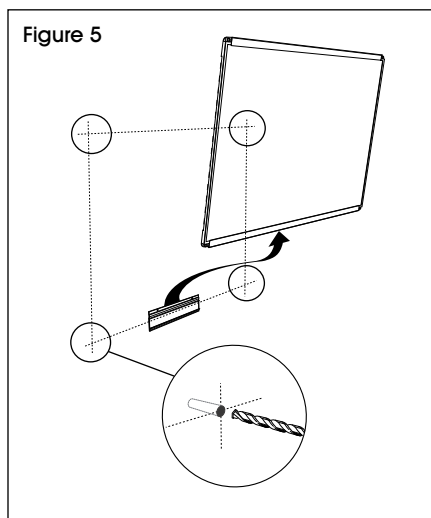

6. Remplacez le tableau sur la tablette. Fixez-le à l'aide de quatre vis n° 10. (Voir Figure 6)

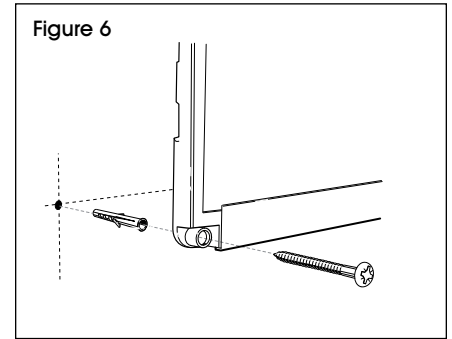

7. Insérez le porte-marqueur de biais sur la tablette d'installation. (Voir Figure 7)

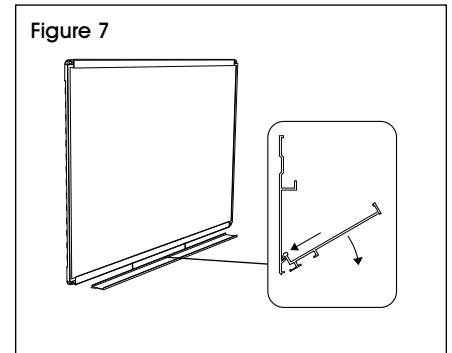

8. Placez les embouts du porte-marqueur sur chaque extrémité. (Voir Figure 8)

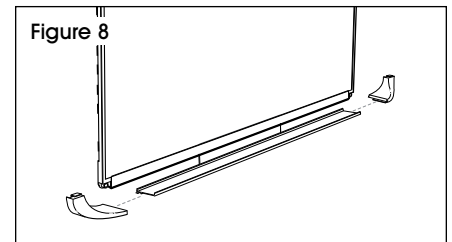

9. Placez les couvre-coins sur le tableau. (Voir Figure 9)

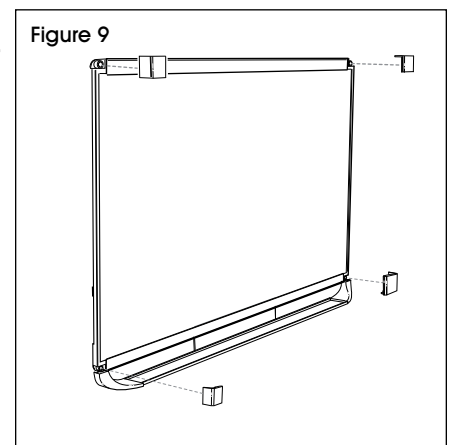

ENTRETIEN

- Avant la première utilisation, nettoyez le tableau avec un savon doux et de l'eau (n'utilisez pas de nettoyeurs abrasifs). Rincez et séchez complètement avec un chiffon doux.
- Utilisez uniquement des marqueurs effaçables à sec. Tout autre marqueur pourrait endommager définitivement la surface d'écriture. Remplacez les marqueurs au moins une fois par an pour un nettoyage optimal.
- Utilisez un effaceur propre pour enlever l'encre effaçable à sec du tableau. Un nettoyant pour tableau effaçable à sec peut être parfois utilisé pour retirer la graisse, la saleté et le résidu d'encre qui peuvent s'accumuler sur la surface du tableau.
- Évitez de laisser les marques sur le tableau trop longtemps. L'encre effaçable à sec peut s'avérer difficile à enlever du tableau après une période prolongée.
- N'utilisez pas de ruban adhésif sur la surface du tableau.

ULINE

1 800 295-5510
uline.ca