

ULINE H-5831, H-5832 IN/OUT STAFF BOARD

1-800-295-5510
 uline.com

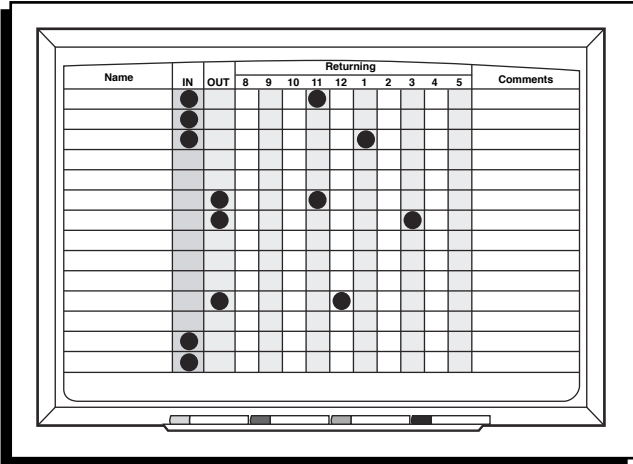

TOOLS NEEDED

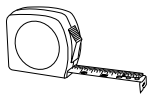

Tape Measure

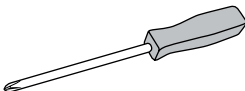

Phillips Screwdriver

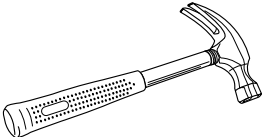

Hammer



Drill

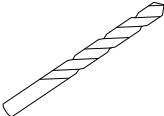

1/4" Drill Bit

PARTS

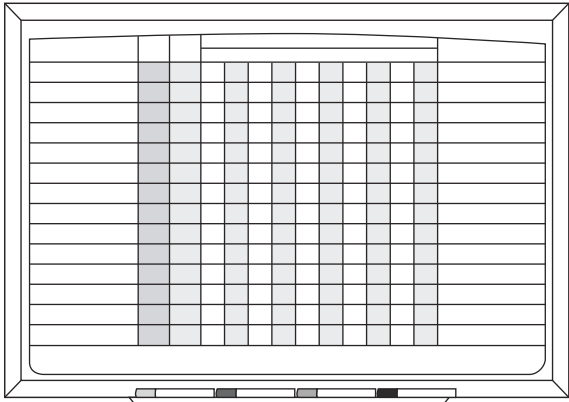

Board x 1

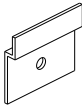

Hanging Bracket
 x 2



Drywall Anchor
 x 2



#10 Screw
 x 2

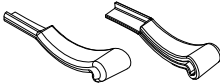

Tray End Cap x 2

OPTIONAL MARKER TRAY INSTALLATION

1. Align tray end caps with marker tray and press into place. (See Figure 1)

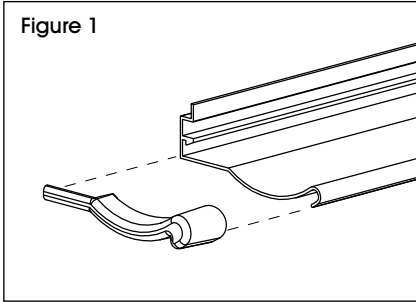

2. Insert marker tray at approximately a 15° angle into back channel of board frame. Rotate tray to fully engage bottom of channel. (See Figure 2)

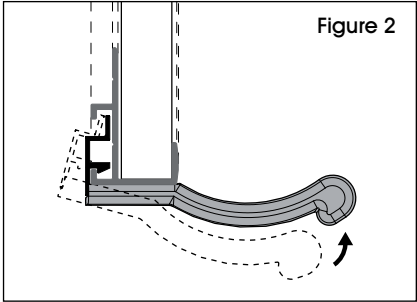

 **NOTE:** Attach tray to side of frame with logo label.

MOUNTING

1. Determine board location. To position top hanging brackets, mark center hole of hanger 4" from outside edge of board and 7/8" down from top of board. Drill holes for each bracket using a 1/4" drill bit. (See Figures 3-4)
2. Insert wall anchors into holes. Insert screws through hanging brackets into the wall anchor. Tighten firmly. (See Figure 5)
3. Holding the board at approximately a 15° angle, place the channel in the back of the frame over the wall hangers. Lower the board so it is flush to the wall. (See Figure 6)

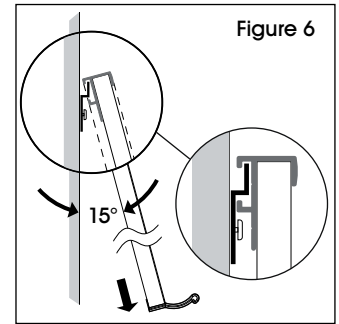
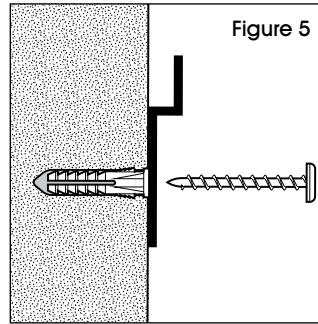
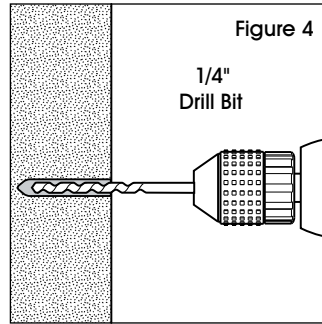
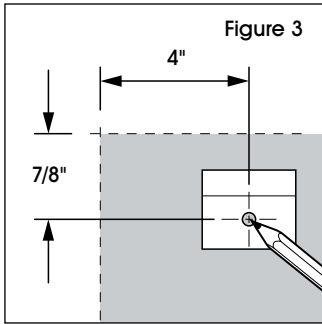

MAINTENANCE

- Clean board prior to first use with mild soap and water (do not use abrasive cleaners). Rinse and dry thoroughly with a soft cloth.
- Use only dry erase markers. Other markers may permanently damage the writing surface. For best erasing results, replace markers at least once a year.
- Use a clean eraser to remove dry erase ink from the board surface. Occasionally, use dry erase board cleaner to remove grease, dirt and dry erase ink residue that may build up on the board surface.
- Avoid leaving marks on the board surface for prolonged periods. Dry erase ink may become difficult to erase over time.
- Do not use adhesive tape on board surface.

ULINE

1-800-295-5510
uline.com

ULINE H-5831, H-5832
**TABLERO DE PERSONAL
 PRESENTE O AUSENTE**

800-295-5510
 uline.mx

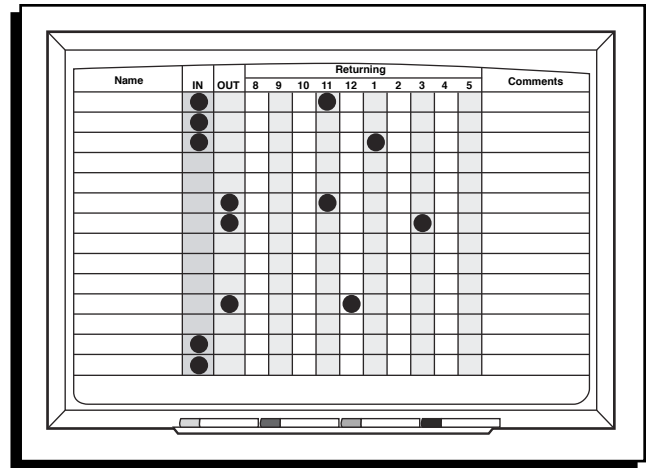

HERRAMIENTAS NECESARIAS

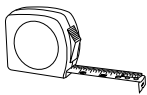

Metro

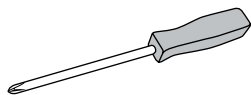

Desarmador de Cruz

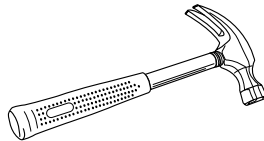

Martillo



Taladro

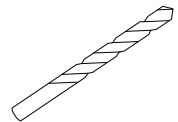

Broca de 1/4"

PARTES

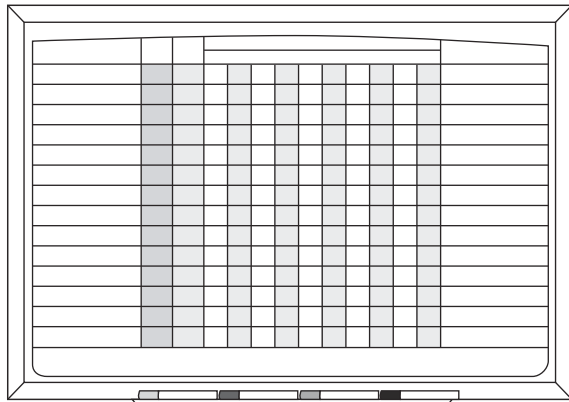

1 Tablero

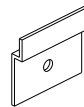

2 Soportes para Colgar



2 Taquetes para Panel de Yeso



2 Tornillos #10

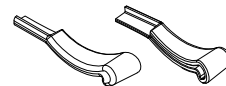

2 Tapas para los Extremos de la Bandeja

INSTALACIÓN DE LA BANDEJA OPCIONAL PARA MARCADORES

1. Alinee las tapas con la bandeja para marcadores y presiónelas para que queden en su lugar. (Vea Diagrama 1)

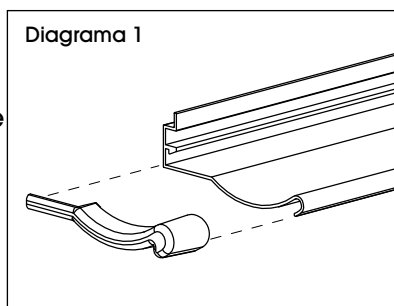

2. Inserte la bandeja para marcadores en el canal de la parte posterior del tablero en un ángulo aproximado de 15°. Gire la bandeja para que se inserte por completo en el canal. (Vea Diagrama 2)

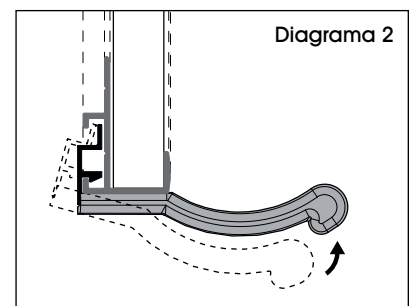

NOTA: Coloque la bandeja del lado del marco con la etiqueta del logo.

INSTALACIÓN

1. Elija la ubicación del tablero. Para colocar los soportes superiores para colgar, marque el orificio central del soporte a 10 cm (4") hacia un costado y 2 cm (7/8") hacia abajo del borde exterior del tablero. Perfore orificios para cada soporte usando una broca para taladro de 1/4". (Vea Diagramas 3-4)
2. Inserte los taquetes en los orificios. Inserte los tornillos en los taquetes a través de los soportes para colgar. Apriete con firmeza. (Vea Diagrama 5)
3. Sostenga el tablero en un ángulo aproximado de 15°, coloque el canal en la parte posterior del tablero sobre los soportes para colgar en la pared. Baje el tablero para que quede a ras de la pared. (Vea Diagrama 6)

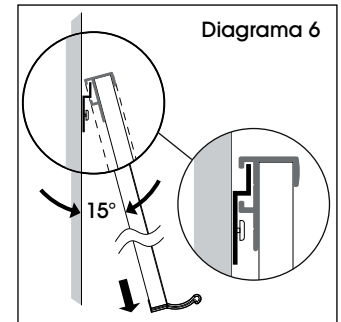
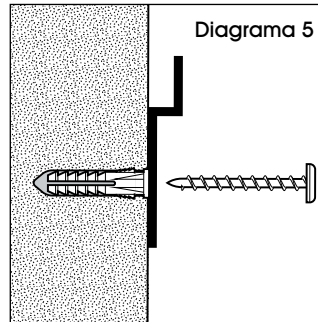
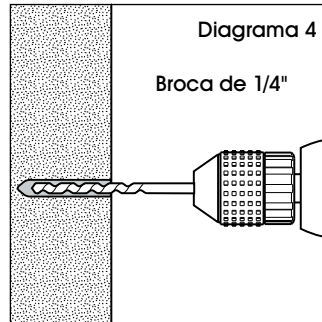
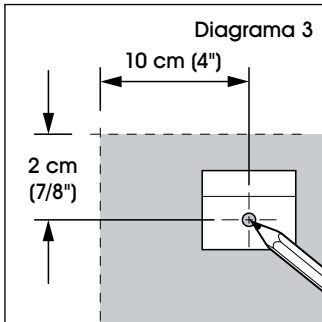

MANTENIMIENTO

- Limpie el tablero con agua y un jabón suave antes de usarlo por primera vez (no use limpiadores abrasivos). Enjuague y seque bien con un trapo suave.
- Use solo marcadores para pizarrón blanco. Otros marcadores podrían dañar permanentemente la superficie para escribir. Para borrar mejor, reemplace los marcadores por lo menos una vez al año.
- Use un borrador limpio para remover del tablero la tinta de los marcadores. De vez en cuando, use limpiador para pizarrón blanco para eliminar la grasa, suciedad y residuos de tinta de marcadores que podrían acumularse en la superficie del tablero.
- Evite dejar marcas en el tablero por periodos prolongados. Con el tiempo, la tinta de los marcadores podría ser difícil de borrar.
- No coloque cinta adhesiva sobre la superficie del tablero.

ULINE

800-295-5510

uline.mx

TABLEAU DE PRÉSENCE DU PERSONNEL

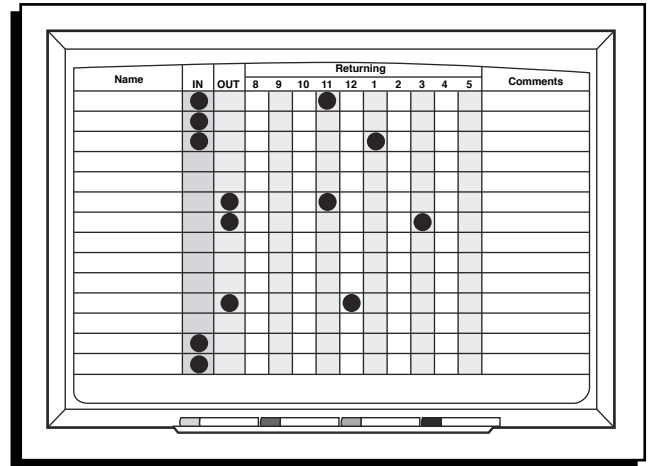

OUTILS REQUIS

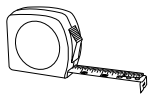

Ruban à mesurer

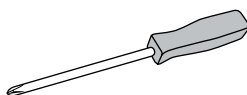

Tournevis cruciforme

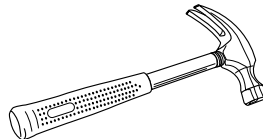

Marteau



Perceuse

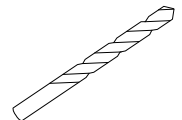

Mèche de perceuse
de 1/4 po

PIÈCES



Tableau x 1



Support d'accrochage
x 2

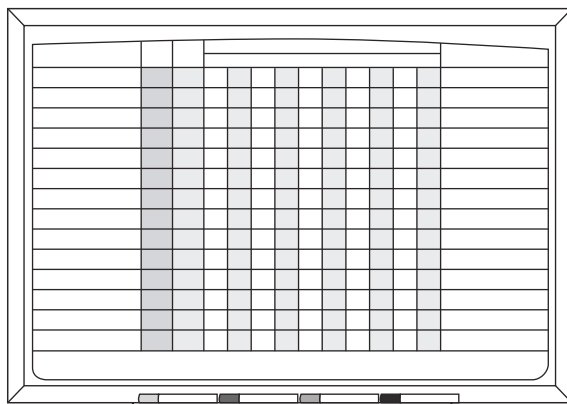
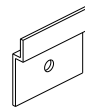

Ancrage pour
cloison sèche x 2



Vis de calibre 10 x 2

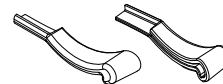

Embout du porte-marqueur x 2

INSTALLATION OPTIONNELLE DU PORTE-MARQUEUR

1. Alignez les embouts avec le porte-marqueur et insérez-les en place. (Voir Figure 1)

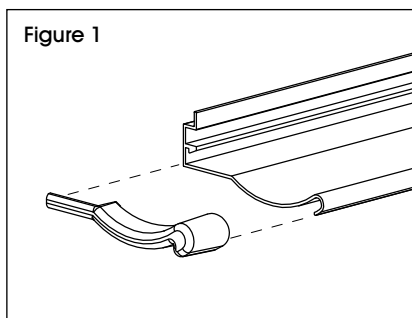

Figure 1

2. Insérez le porte-marqueur dans la rainure au dos du cadre à un angle d'environ 15°. Faites pivoter le porte-marqueur afin de complètement l'enclencher dans la rainure. (Voir Figure 2)

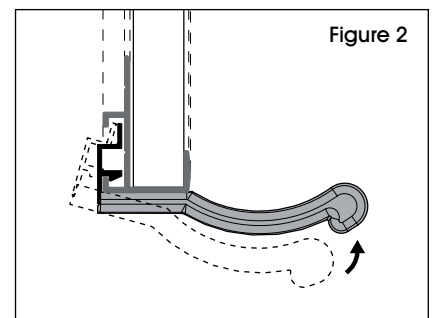

Figure 2



REMARQUE : Fixez le porte-marqueur sur le côté du cadre portant le logo.

MONTAGE

1. Déterminez l'emplacement du tableau. Afin de positionner les supports d'accrochage supérieurs, marquez le trou central du support à 10 cm (4 po) du bord latéral du tableau et à 2 cm (7/8 po) du haut du tableau. Percez des trous pour chaque support avec une mèche de perceuse de 1/4 po. (Voir Figures 3 et 4)
2. Insérez les ancrages muraux dans les trous. Insérez les vis dans les ancrages en les faisant passer à travers les supports d'accrochage. Serrez-les fermement. (Voir Figure 5)
3. En maintenant le tableau incliné à environ 15°, placez la rainure au dos du cadre par-dessus les supports. Abaissez le tableau contre le mur. (Voir Figure 6)

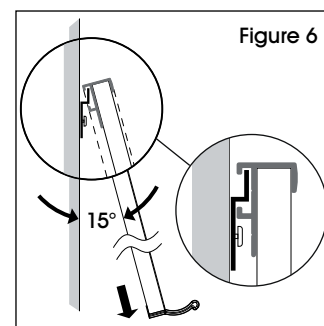
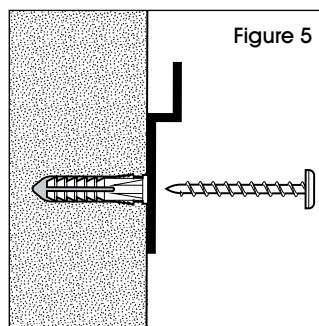
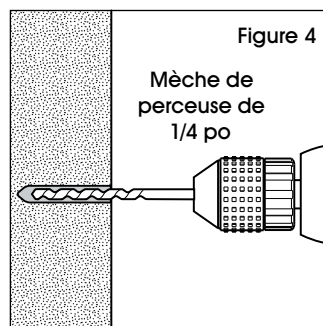
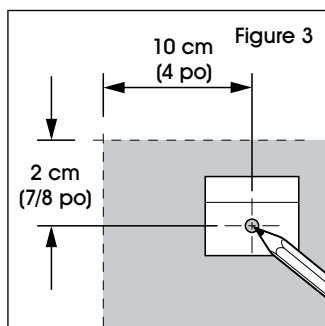

ENTRETIEN

- Nettoyez le tableau avec de l'eau et un savon doux (n'utilisez pas de détergent abrasif) avant la première utilisation. Rincez, puis séchez avec un chiffon doux.
- Utilisez uniquement des marqueurs effaçables à sec. D'autres marqueurs risquent d'endommager de manière permanente la surface d'écriture. Pour un effacement optimal, remplacez les marqueurs au minimum une fois par an.
- Utilisez un effaceur propre pour enlever l'encre de la surface du tableau. Utilisez occasionnellement un nettoyant pour tableau à effacement à sec pour éliminer la graisse, la poussière et les résidus d'encre qui peuvent s'accumuler sur la surface du tableau.
- Évitez de laisser les inscriptions pendant une période prolongée. L'encre effaçable à sec peut devenir difficile à effacer au fil du temps.
- N'utilisez pas de ruban adhésif sur la surface du tableau.

ULINE

1 800 295-5510
uline.ca