

# ULINE H-6170 BRADLEY® MOBILE EYEWASH STATION WASTE CART

1-800-295-5510  
uline.com

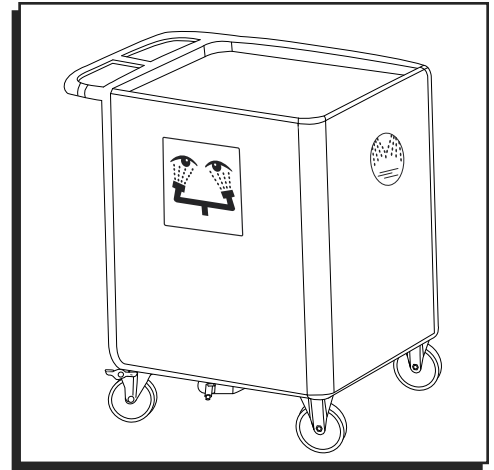

## PARTS

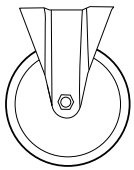

Rigid Caster x 2

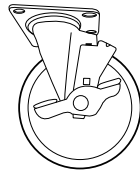

Total Lock Swivel Caster x 2

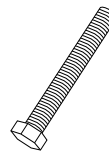

5/8" - 18 x 3/4" Hex Cap Screw x 16



5/8" Flat Washer x 16

## INSTALLATION

1. Attach the casters to the bottom of the cart with the hardware provided. (See Figure 1)

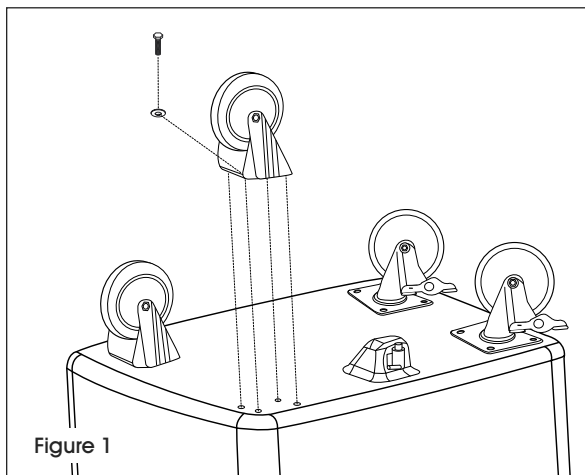

Figure 1



**NOTE:** The rigid casters are attached to the front of the cart and the total lock swivel casters are attached to the back of the cart. Line up the casters with the studs on the bottom of the cart and secure in place.

2. Lower the eyewash unit onto the cart tray. (See Figure 2)

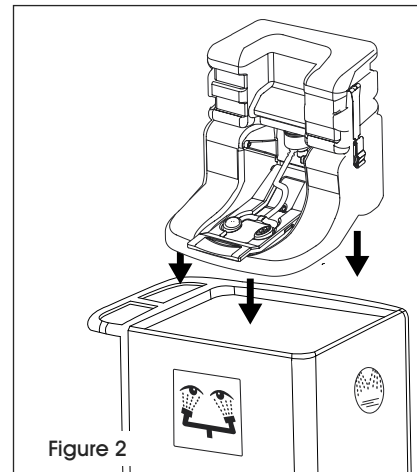

Figure 2



**NOTE:** The eyewash unit should be positioned on the cart (facing either eyewash sign) before the tank is filled. Ensure the petcock is closed before filling the tank.

3. After the eyewash unit is properly positioned, fill the eyewash tank following the instructions outlined on the front of the eyewash unit.

**ULINE** H-6170

# BRADLEY® CARRITO PARA DESECHOS DE ESTACIÓN LAVAOJOS MÓVIL

800-295-5510  
uline.mx

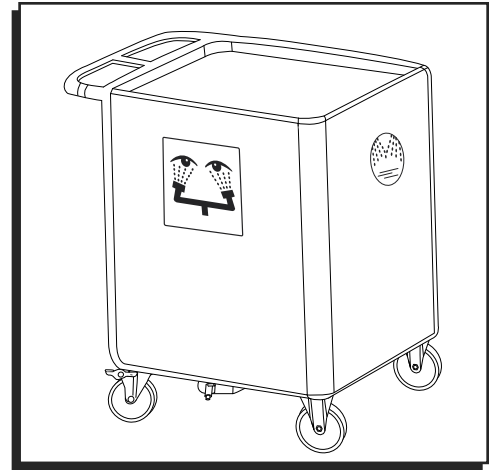

## PARTES

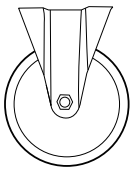

2 Ruedas Rígidas

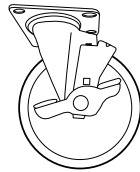

2 Ruedas Giratorias con Bloqueo Total

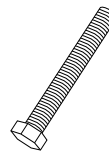

16 Tornillos de Cabeza Hexagonal de 5/8" - 18 x 3/4"



16 Rondanas Planas de 5/8"

## INSTALACIÓN

1. Instale las ruedas, con la tornillería incluida, en la parte de abajo del carrito. (Vea Diagrama 1)



Diagrama 1



**NOTA:** Las ruedas rígidas se instalan en la parte frontal del carrito y las ruedas giratorias de bloqueo total en la parte trasera. Alinee las ruedas con la parte de abajo del carrito y fije en su lugar.

2. Coloque la estación lavaojos en la bandeja del carrito. (Vea Diagrama 2)

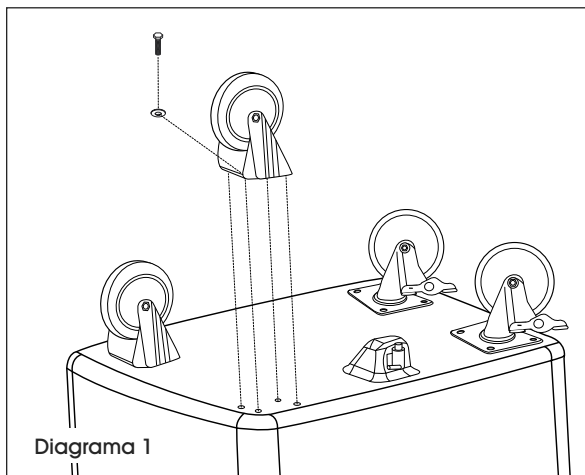

Diagrama 2



**NOTA:** La unidad se debe colocar sobre el carrito (con el letrero de lavaojos en el frente) antes de que llene el tanque. Asegúrese de que la llave de desagüe esté cerrada antes de llenar el tanque.

3. Antes de que la estación quede debidamente colocada, siga las instrucciones ubicadas en el frente del tanque para llenarlo.

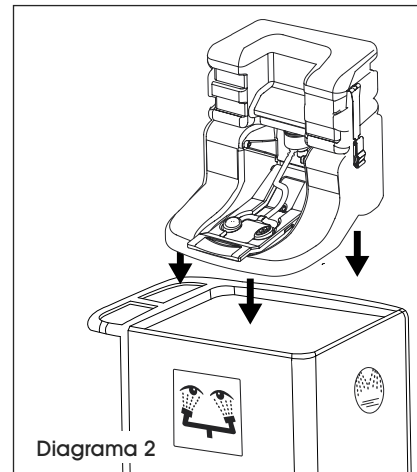
**ULINE** H-6170

# BRADLEY® CHARIOT À DÉCHETS DE DOUCHE OCULAIRE MOBILE

1 800 295-5510

uline.ca

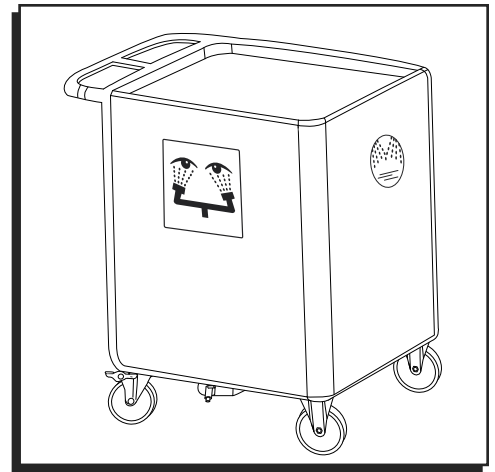

## PIÈCES

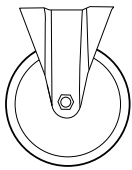

Roulette rigide x 2

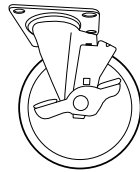

Roulette pivotante verrouillable x 2

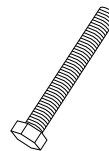

Vis d'assemblage à tête hexagonale  
5/8 po - 18 x 3/4 po x 16



Rondelle plate - 5/8 po x 16

## INSTALLATION

1. Fixez les roulettes au bas du chariot à l'aide du matériel inclus. (Voir Figure 1)

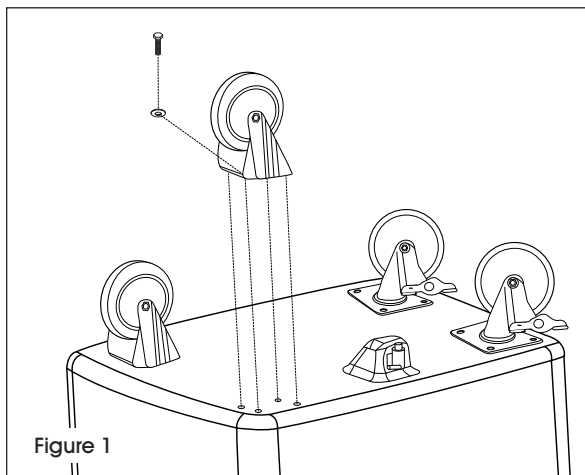

Figure 1



**REMARQUE :** Les roulettes rigides sont installées à l'avant du chariot et les roulettes pivotantes verrouillables sont installées à l'arrière du chariot. Alignez les roulettes avec les marques sur le bas du chariot et sécurisez les en place.

2. Installez la douche oculaire à l'intérieur du chariot. (Voir Figure 2)

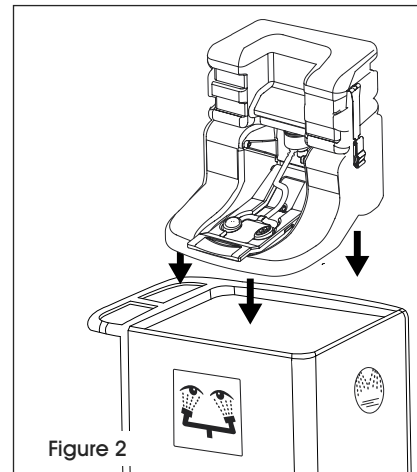

Figure 2



**REMARQUE :** L'unité de lavage oculaire devrait être placée sur le chariot (faisant face au signe de lavage oculaire) avant le remplissage du réservoir. Assurez-vous que le robinet de purge est fermé avant de remplir le réservoir.

3. Une fois que l'unité de lavage oculaire est correctement positionnée, remplissez le réservoir de lavage oculaire conformément aux instructions indiquées à l'avant de l'unité du lavage oculaire.