

ULINE H-6278, H-6279
H-6280
**MOBILE TRAINING
TABLE**

1-800-295-5510
uline.com

Para Español, vea páginas 3-4.
Pour le français, consulter les pages 5-6.

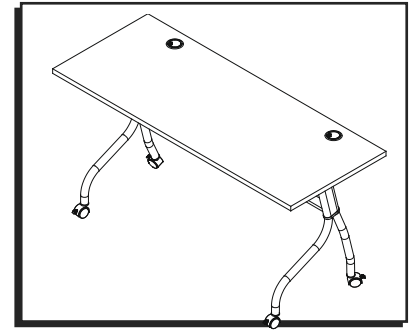

TOOLS NEEDED

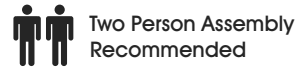
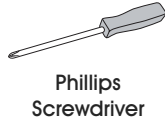

PARTS

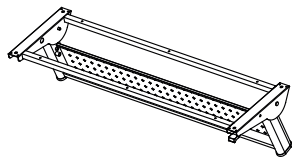
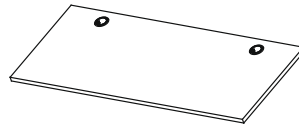
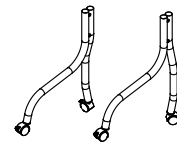

Table Frame x 1



Tabletop Panel x 1



Leg x 2

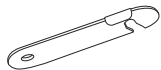

Bracket x 2



Knob x 4



Bolt x 4



Washer x 4



5/8" Screw x 10

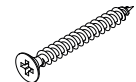

1 1/16" Screw x 8

ASSEMBLY

NOTE: Assemble on a smooth, non-marring surface to avoid scratching.

NOTE: Do not fully tighten bolts and screws until assembly is complete.

IMPORTANT! Check that all parts are included.

1. Insert legs into socket on table frame. Threaded hole side must be pointed inward. (See Figure 1)

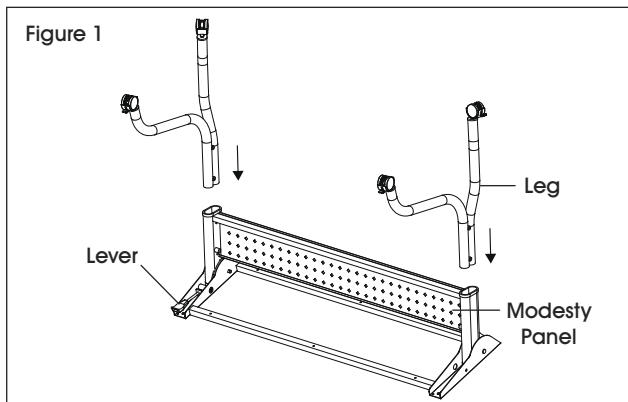

2. Use two bolts to secure leg. Repeat for remaining leg. (See Figure 2)

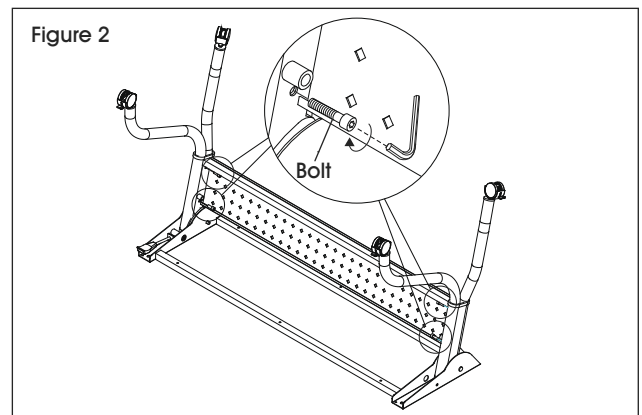

3. Place tabletop panel upside down. With second person, align table frame with holes in tabletop panel.

ASSEMBLY CONTINUED

4. With second person holding assembled base in place, use two 5/8" screws to secure each corner of table frame. (See Figure 3)
5. Use three 1⁹/₁₆" screws to secure each side along length of table frame. (See Figure 3)



NOTE: Fully tighten bolts and screws.

6. With second person, set table upright. Adjust casters to compensate for uneven floors.

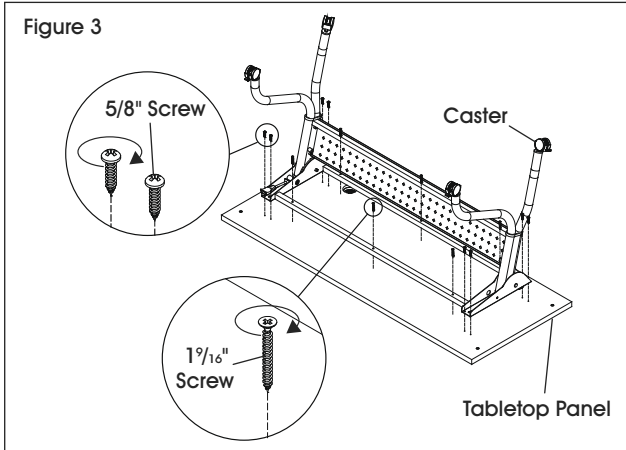

JOINING TABLES WITH GANGING BRACKETS

1. Align washer and bracket with hole at front of table on the corner adjacent to second table to connect. Use knob to secure. (See Figure 4)
2. Align washer with hole at front of second table and use knob to secure. Do not fully tighten knob. (See Figure 4)

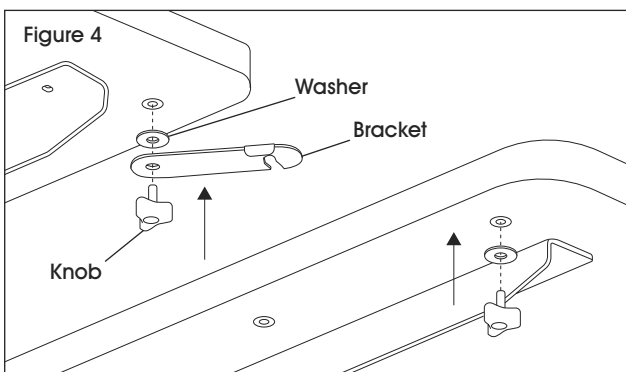

3. Push tables together and rotate bracket from first table to hook onto knob of second table between washer and knob. Tighten knob of second table to secure bracket. (See Figure 5a-b)

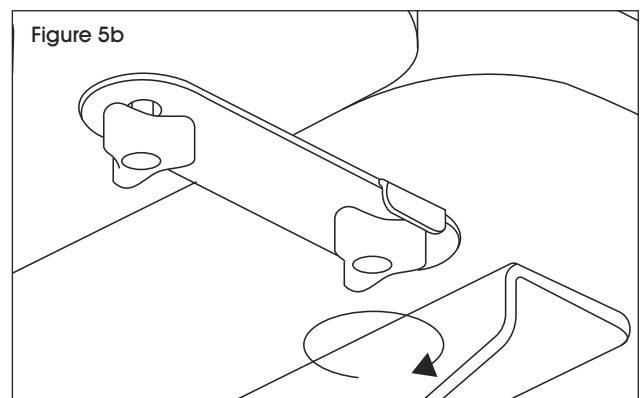
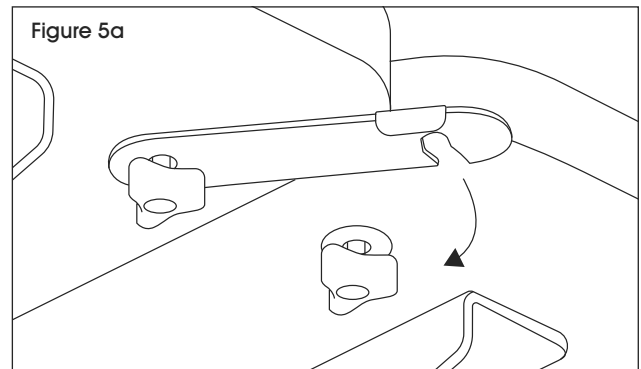

4. Repeat steps 1-5 to install ganging bracket at back of tables.

ULINE

1-800-295-5510

uline.com

ULINE H-6278, H-6279
H-6280
**MESA MÓVIL PARA
CAPACITACIÓN**

800-295-5510
uline.mx

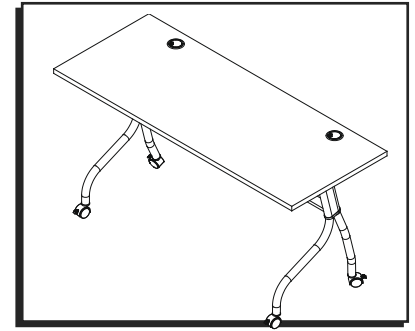

HERRAMIENTAS NECESARIAS



Llave Allen
(incluida)



Llave de Boca
Abierta (incluida)

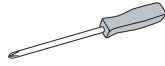

Desarmador
de Cruz



Taladro
(opcional)



Se Recomienda Armar
Entre Dos Personas

PARTES

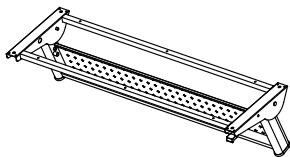

1 Armazón de Mesa

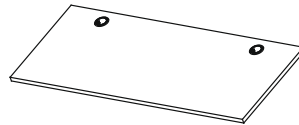

1 Panel de Cubierta

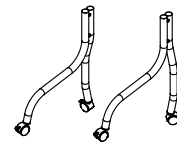

2 Patas

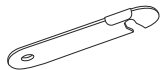

2 Soportes



4 Perillas



4 Pernos



4 Rondanas



10 Tornillos de
5/8"

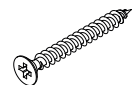

8 Tornillos de
1/4"

ENSAMBLE



NOTA: Ensamble sobre una superficie lisa que no deje marcas para evitar rayones.



NOTA: No apriete los pernos y tornillos por completo hasta que termine de ensamblar.



¡IMPORTANTE! Verifique que todas las partes estén incluidas.

1. Inserte las patas en las ranuras del armazón de mesa. El orificio roscado debe quedar hacia adentro. (Vea Diagrama 1)

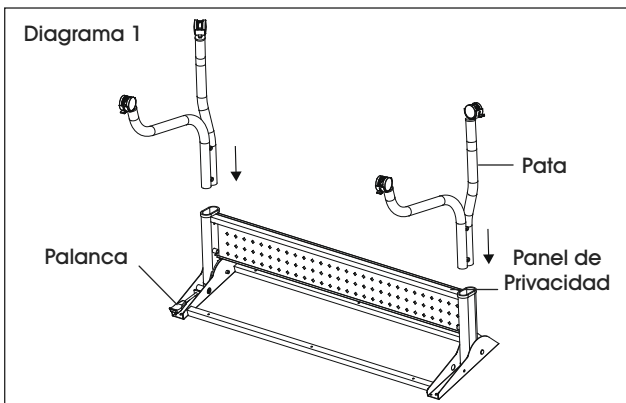

2. Utilice dos pernos para fijar la pata. Repita para la pata restante. (Vea Diagrama 2)

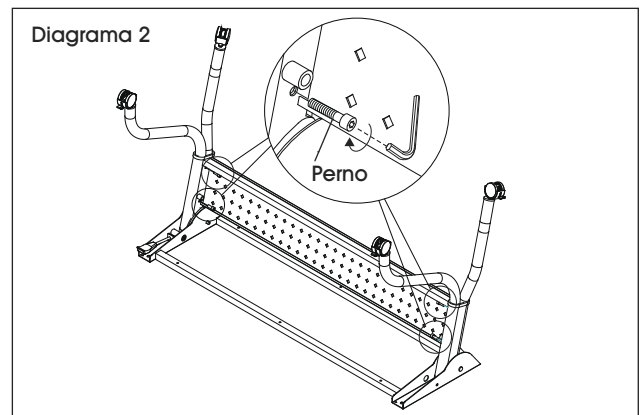

3. Voltee el panel de cubierta. Con la ayuda de la otra persona, alinee el armazón de mesa con los orificios en el panel de cubierta.

CONTINUACIÓN DEL ENSAMBLE

4. Con la otra persona sosteniendo la base ensamblada en su lugar, utilice dos tornillos de 5/8" para asegurar cada esquina del armazón de mesa. (Vea Diagrama 3)
5. Utilice tres tornillos de 1 1/16" para asegurar cada lado a lo largo del armazón de mesa. (Vea Diagrama 3)



NOTA: Apriete los pernos y tornillos por completo.

6. Con la ayuda de la otra persona, enderece la mesa. Ajuste las ruedas para compensar pisos desnivelados.

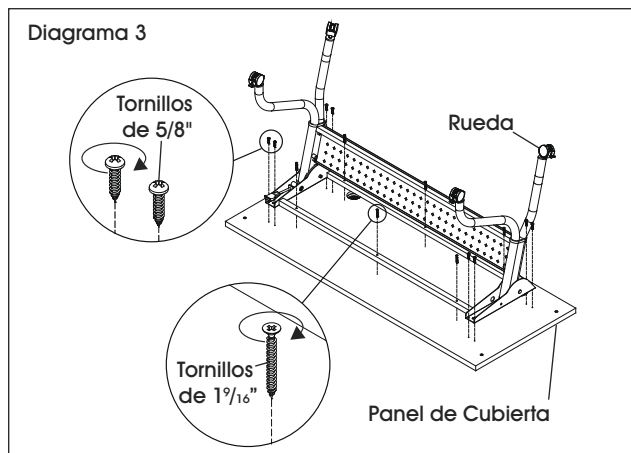

UNIR MESAS CON SOPORTES DE ACOPLAMIENTO

1. Alinee la rondana y el soporte con el orificio en la parte frontal de la mesa hacia la esquina al lado de la segunda mesa para conectar. Utilice la perilla para fijar. (Vea Diagrama 4)
2. Alinee la rondana con el orificio en la parte frontal de la segunda mesa y utilice la perilla para fijar. No apriete la perilla por completo. (Vea Diagrama 4)

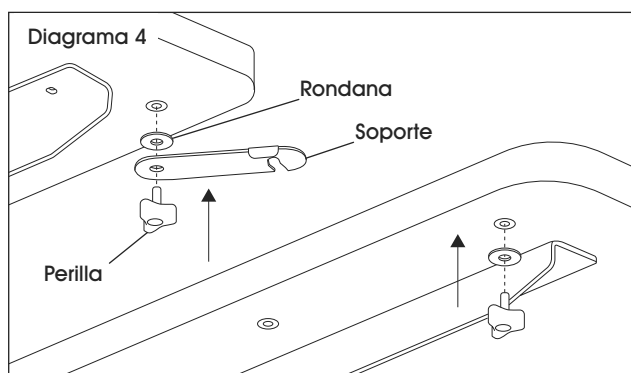

3. Una las mesas y gire el soporte de la primera mesa para engancharlo a la perilla de la segunda mesa entre la rondana y la perilla. Apriete la perilla de la segunda mesa para asegurar el soporte. (Vea Diagramas 5a-b)

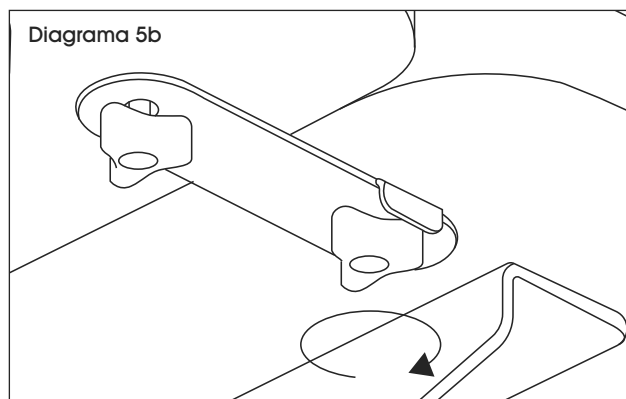
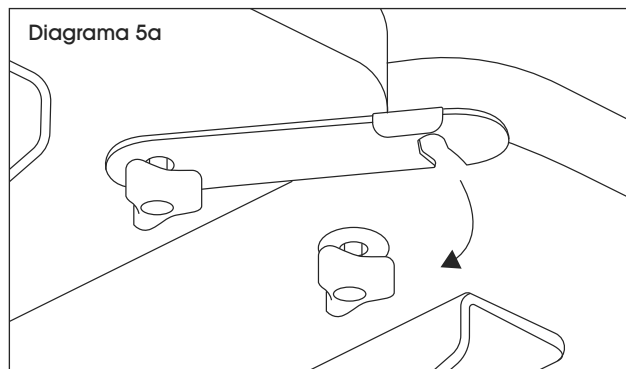

4. Repita los pasos 1-5 para instalar el soporte de acoplamiento en la parte posterior de las mesas.

ULINE

800-295-5510
uline.mx

TABLE DE FORMATION MOBILE

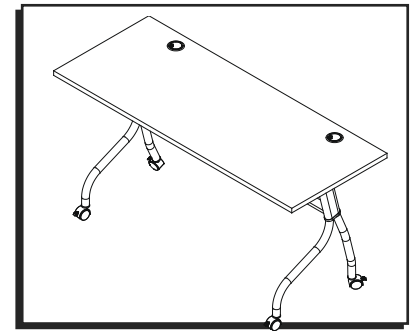

OUTILS REQUIS



Clé Allen
(inclus)



Clé à fourche
(inclus)

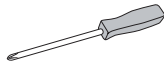

Tournevis
cruciforme



Perceuse
(optionnel)



Montage à deux
personnes recommandé

PIÈCES

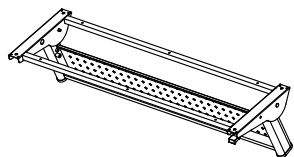

Cadre de table x 1

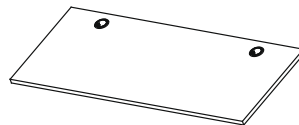

Surface de table x 1

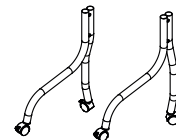

Pied x 2



Support x 2



Bouton x 4



Boulon x 4



Rondelle x 4



Vis de 5/8 po x 10



Vis de 1 1/16 po x 8

MONTAGE



REMARQUE : Montez l'article sur une surface lisse et non marquante afin d'éviter les rayures.



REMARQUE : Attendez d'avoir terminé le montage pour serrer complètement les boulons et vis.



IMPORTANT! Vérifiez que toutes les pièces sont incluses.

1. Insérez les pieds dans l'emboîture du cadre de la table. Le côté du trou fileté doit être orienté vers l'intérieur. (Voir Figure 1)

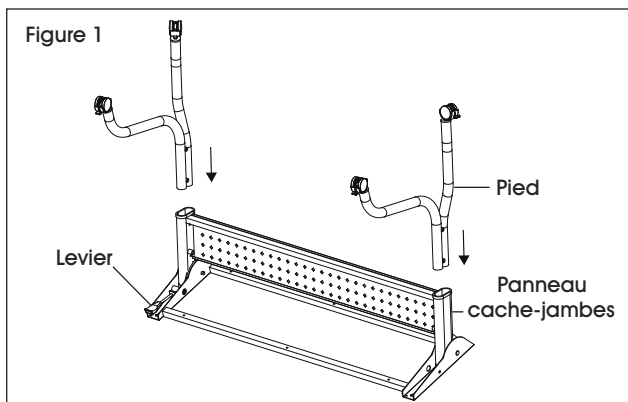

2. Utilisez deux boulons pour fixer le pied. Répétez l'opération pour l'autre pied. (Voir Figure 2)

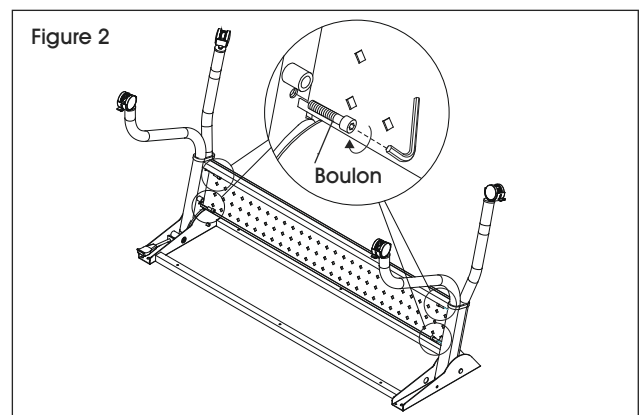

3. Placez la surface de table à l'envers. Avec l'aide d'une deuxième personne, alignez le cadre de la table avec les trous de la surface de table.

MONTAGE SUITE

4. Avec l'aide d'une deuxième personne tenant la base assemblée en place, utilisez deux vis de 5/8 po pour fixer chaque coin du cadre de la table. (Voir Figure 3)
5. Utilisez trois vis de 1 1/16 po pour fixer chaque côté sur la longueur du cadre de la table. (Voir Figure 3)

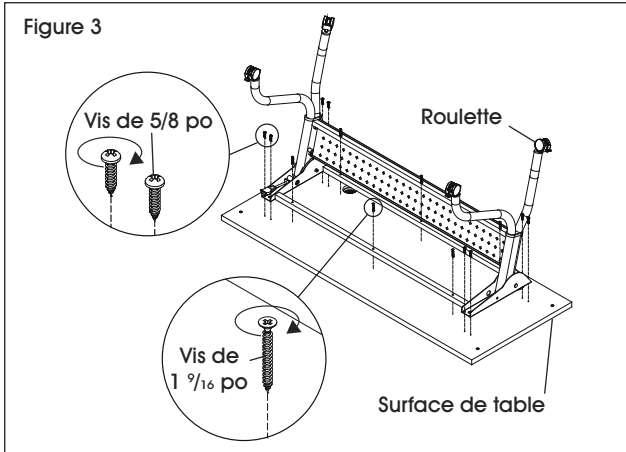

 **REMARQUE :** Serrez fermement les vis et les boulons.

6. Avec l'aide d'une deuxième personne, positionnez la table à la verticale. Ajustez les roulettes pour compenser les inégalités du sol.

JONCTION DES TABLES AVEC DES ÉTRIERS DE SUPPORT

1. Alignez une rondelle et un support avec le trou au devant de la table sur le coin adjacent à la deuxième table à connecter. Utilisez un bouton pour fixer. (Voir Figure 4)
2. Alignez une rondelle avec le trou au devant de la deuxième table et utilisez un bouton pour fixer. Ne serrez pas complètement le bouton. (Voir Figure 4)

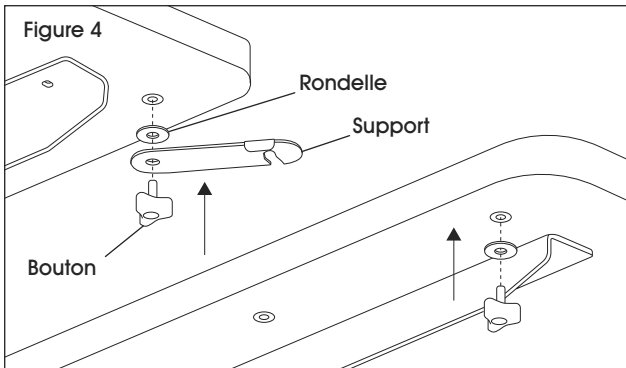

3. Poussez les tables l'une contre l'autre et faites tourner le support de la première table pour l'accrocher entre la rondelle et le bouton de la deuxième table. Serrez le bouton de la deuxième table pour fixer le support. (Voir Figures 5a et 5b)

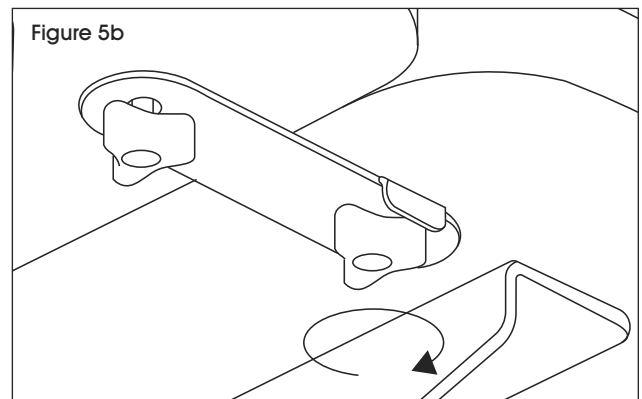
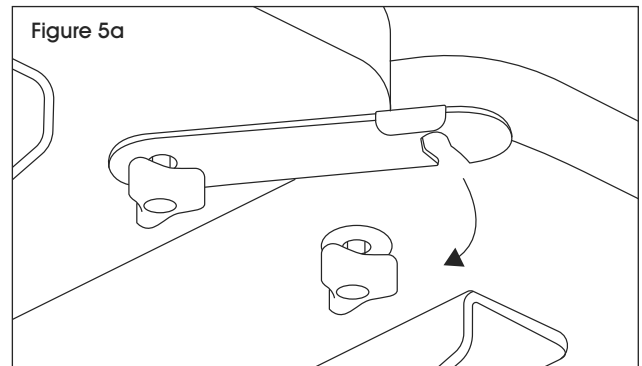

4. Répétez les étapes 1 à 5 pour installer les étriers de support à l'arrière des tables.

ULINE

1-800-295-5510
uline.ca