

ULINE H-6289 SAFETY BOLLARD CHAIN – 10'

1-800-295-5510
uline.com

TOOLS NEEDED



Electric Drill
(Screw Gun)



Nut Driver
Bit

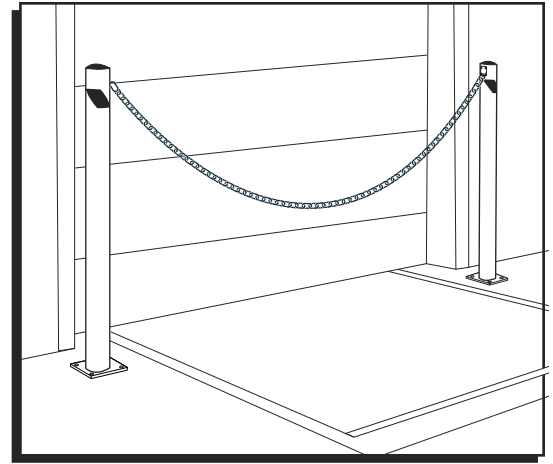

PARTS

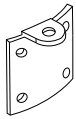

Mounting Plate x 2



Carabiner x 2

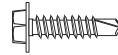

Self-Tapping Screw x 8

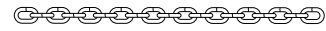

10' Chain x 1

INSTALLATION

1. Attach mounting plate to bollard using provided self-tapping screws and nut driver. (See Figure 1)

 **NOTE:** Use a screw gun with an adjustable clutch. Take care not to overtighten and strip the threads. **DO NOT USE IMPACT TYPE GUNS.**

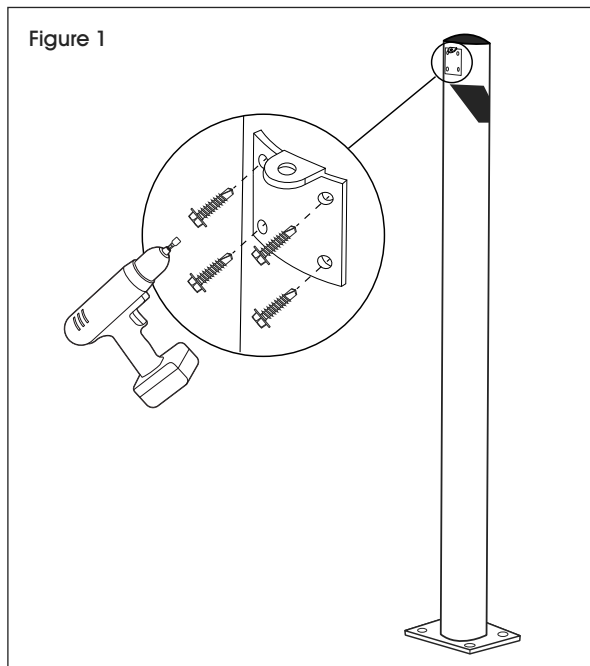

3. Attach carabiners to mounting plates on both bollards. (See Figure 2)

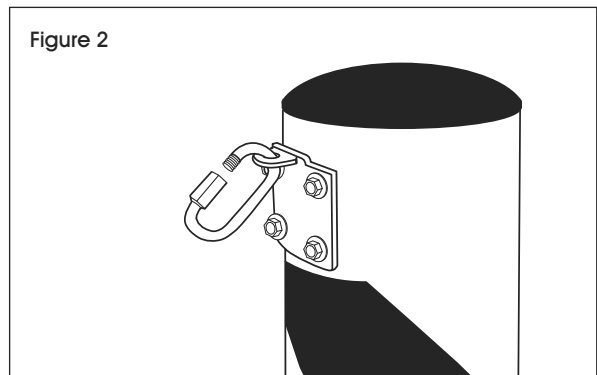

4. Connect chain to carabiners. (See Figure 3)

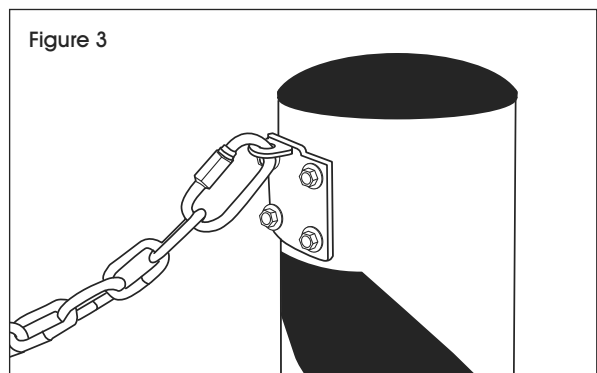

2. Repeat step 1 on second bollard.

ULINE H-6289

CADENA DE ACERO PARA POSTE DE SEGURIDAD – 10'

800-295-5510
uline.mx

HERRAMIENTAS NECESARIAS



Taladro Eléctrico
(Atornillador)



Broca Para
Tuercas

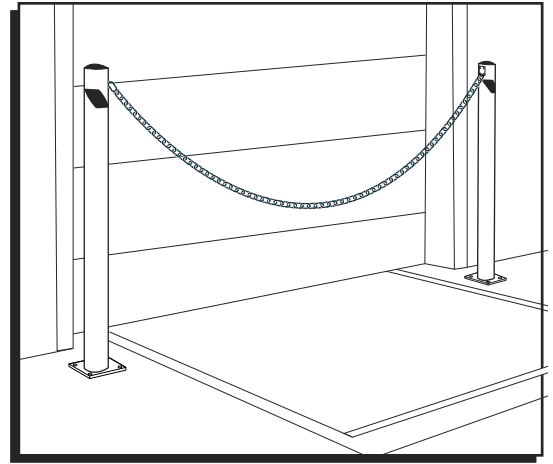

PARTES

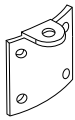

2 Placas de Instalación



2 Mosquetones

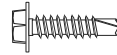

8 Tornillos Auto perforantes



1 10' Cadena

INSTALACIÓN

1. Fije la placa de instalación al poste utilizando los tornillos auto perforantes y una llave de tuercas. (Vea Diagrama 1)



NOTA: Utilice un atornillador con embrague ajustable. Tenga cuidado de no apretar de más y dañar las roscas. **NO UTILICE EL TIPO DE HERRAMIENTAS DE IMPACTO.**

3. Fije los mosquetones para instalar las placas en ambos postes. (Vea Diagrama 2)

Diagrama 2

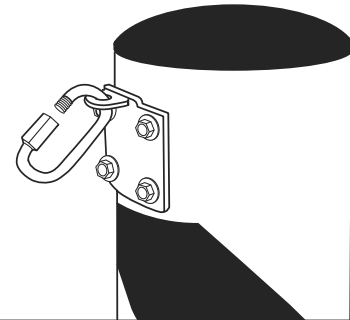

4. Conecte la cadena a los mosquetones. (Vea Diagrama 3)

Diagrama 3

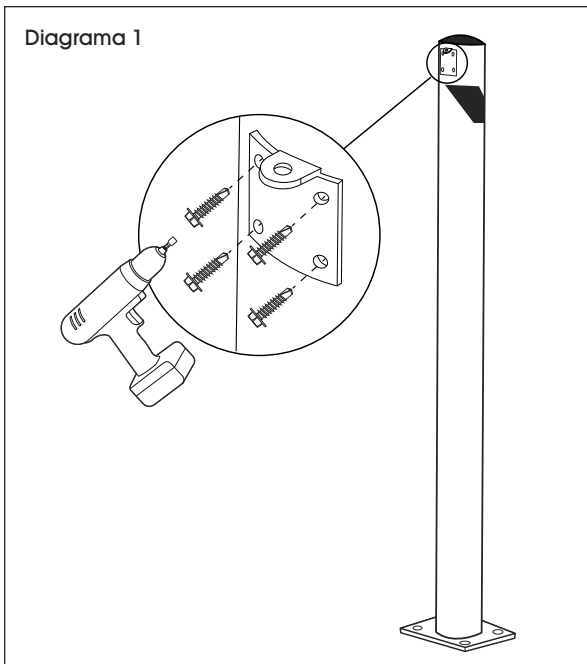
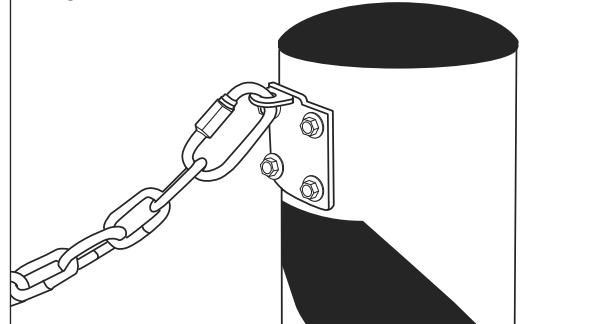

2. Repita el paso 1 en el segundo poste.

ULINE H-6289

1-800-295-5510
uline.ca

CHAÎNE POUR BORNE DE SÉCURITÉ EN ACIER – 10 PI

OUTILS REQUIS



Perceuse électrique
(pistolet à vis)



Tourne-écrou

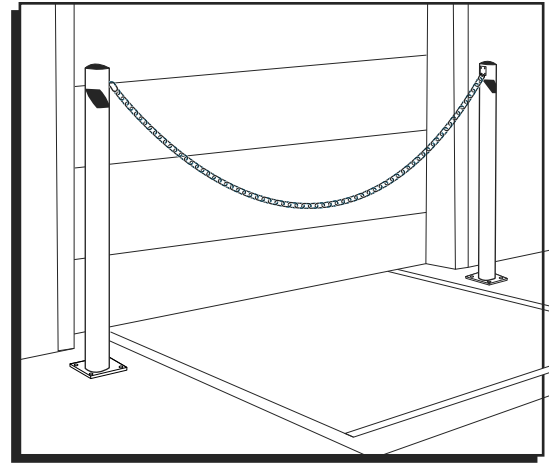

PIÈCES

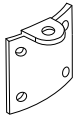

Plaque de montage x 2



Mousqueton x 2

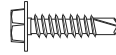

Vis autoforadeuse x 8



Chaîne de 10 pi x 1

INSTALLATION

1. Fixez la plaque de montage à la borne à l'aide de la vis autoforadeuse et d'un tourne-écrou. (Voir Figure 1)

 **REMARQUE :** Utilisez un pistolet à vis avec un embrayage réglable. Prenez garde de ne pas trop serrer et endommager le filetage. **N'UTILISEZ PAS DES PISTOLETS À IMPACT.**

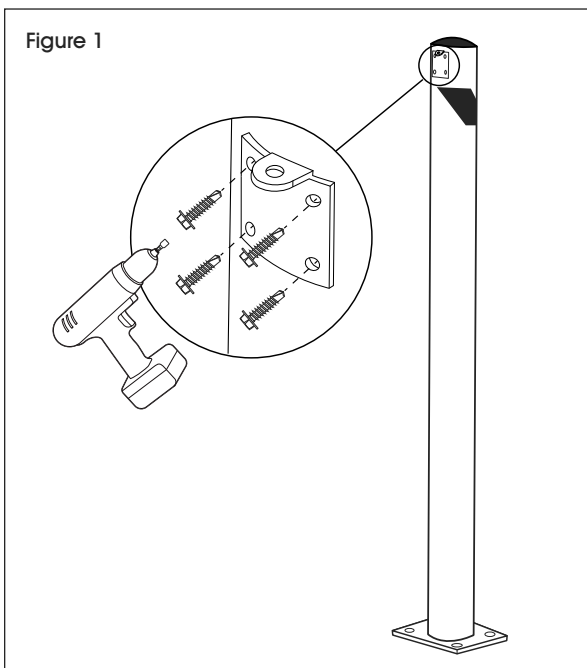

2. Répétez l'étape 1 sur la deuxième borne.

3. Fixez les mouquetons aux plaques de montages sur les deux bornes. (Voir Figure 2)

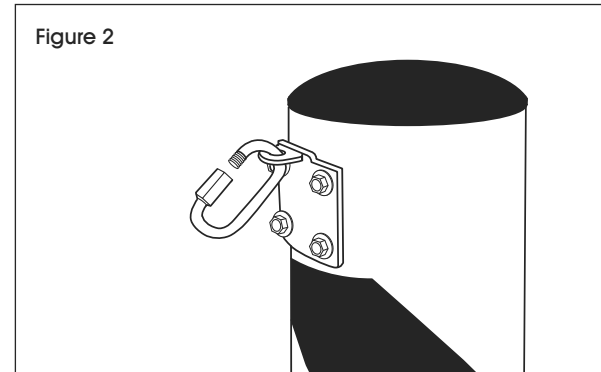

4. Reliez la chaîne aux mouquetons. (Voir Figure 3)

