

ULINE H-6527 SPIN MOP DOLLY

1-800-295-5510
uline.com

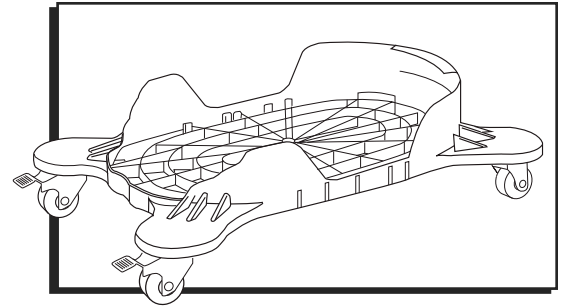

INSTRUCTIONS

1. Press down on the wheel locks to put dolly in locked mode. (See Figure 1)

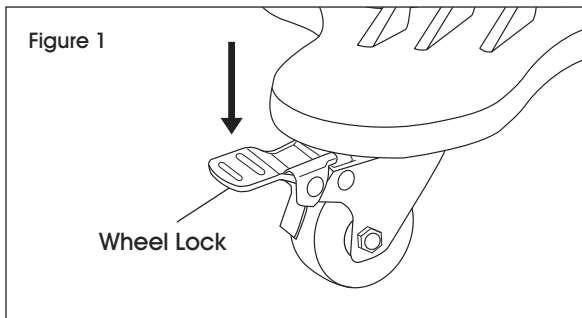

3. Mop bucket and dolly configuration should look like figure below. (See Figure 3)

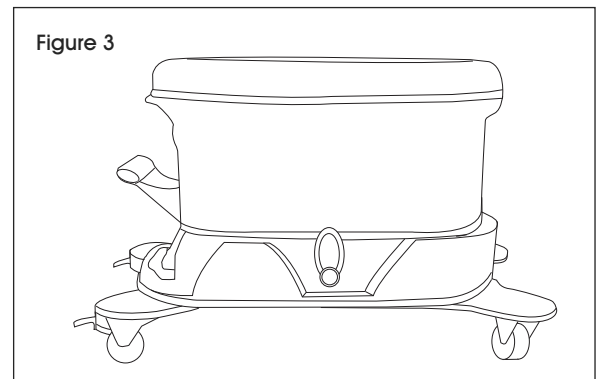

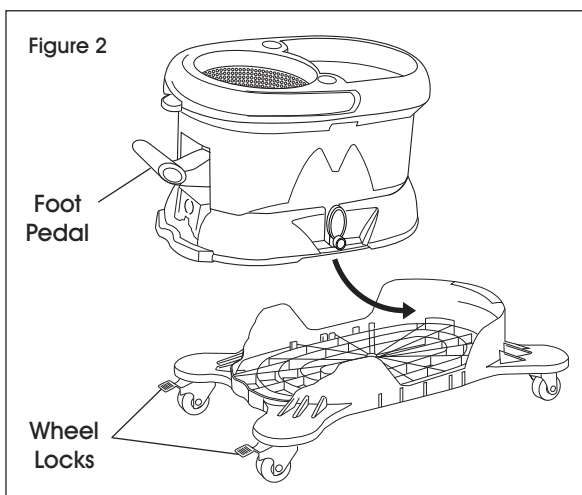

2. In one motion, place mop bucket onto dolly until base of bucket is secured into dolly. (See Figure 2)

 **NOTE:** The mop bucket will only fit one way. The foot pedal of the mop bucket should face towards the side of the dolly with the wheel locks. (See Figure 2)

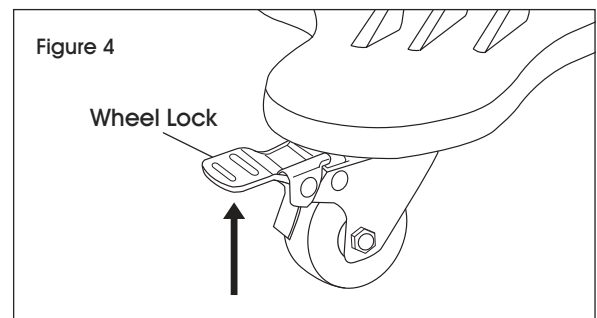

4. To move dolly, unlock wheels by pressing up on wheel locks. (See Figure 4)



 **NOTE:** For best results, lock wheels before wringing out mop.

PLATAFORMA CON RUEDAS PARA SISTEMA DE TRAPEADOR GIRATORIO

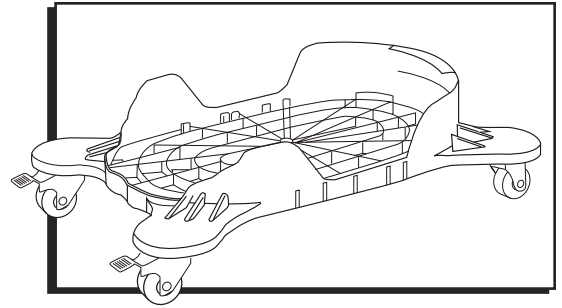

INSTRUCCIONES

1. Presione los seguros de las llantas para poner la plataforma con ruedas en modo seguro. (Vea Diagrama 1)

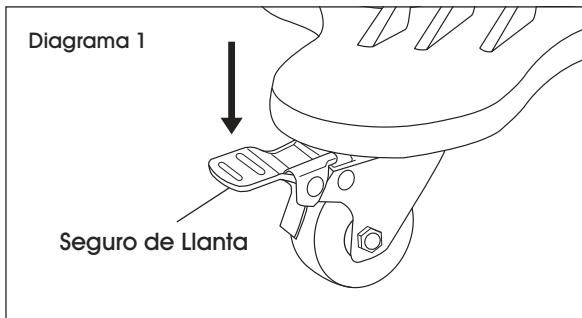

2. En un movimiento, coloque la cubeta dentro de la plataforma con ruedas hasta que la base de la cubeta esté firme sobre la plataforma. (Vea Diagrama 2)

 **NOTA:** La cubeta del trapeador se ajusta de un solo lado. El pedal de la cubeta del trapeador debe ver hacia el lado de la plataforma donde están las ruedas con seguro. (Vea Diagrama 2)

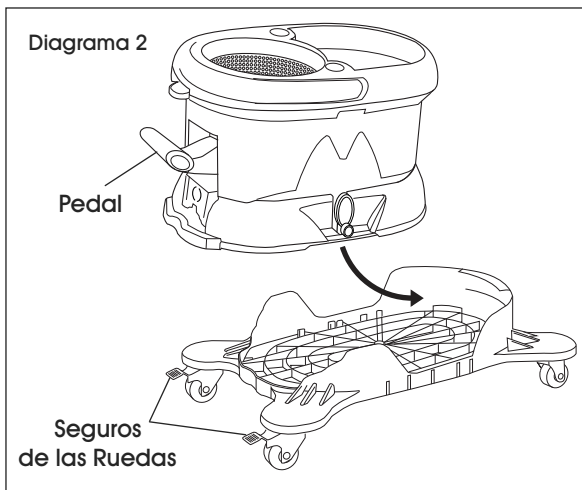

3. La disposición de la cubeta del trapeador y el carrito se debe ver como en el diagrama siguiente. (Vea Diagrama 3)

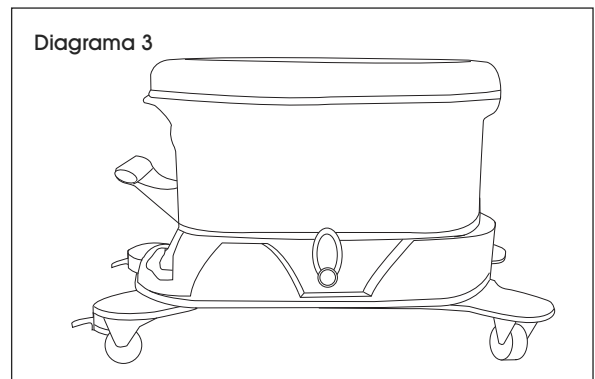

4. Para mover la plataforma, desbloquee las ruedas jalando hacia arriba los seguros de las ruedas. (Vea Diagrama 4)

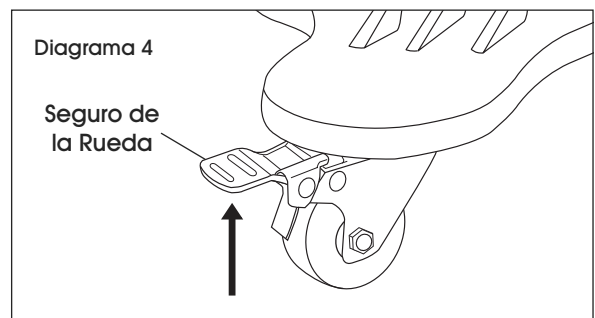

 **NOTA:** Para mejores resultados, asegure las ruedas antes de exprimir el trapeador.

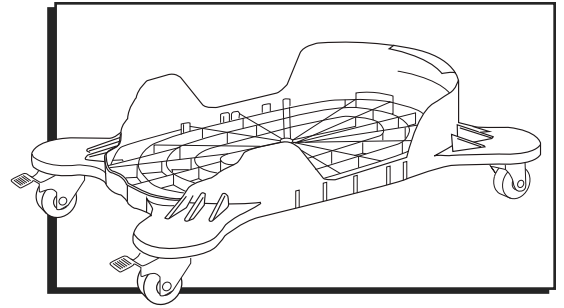
**SOCLE ROULANT POUR
SYSTÈME D'ESSORAGE
DE VADROUILLE ROTATIF****INSTRUCTIONS**

1. Poussez les leviers de frein des roues vers le bas pour mettre le socle en mode de verrouillage. (Voir Figure 1)

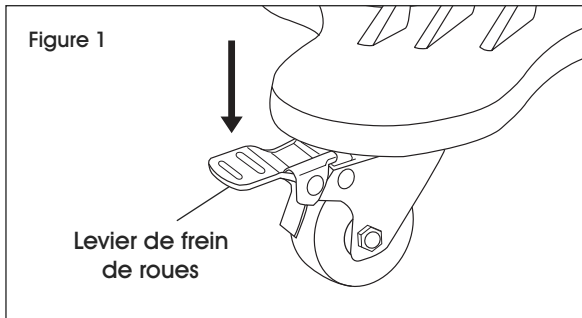

2. D'un mouvement, placez le seau à vadrouille sur le socle de sorte que le seau s'enclenche fermement sur le socle. (Voir Figure 2)

 **REMARQUE :** Le seau ne s'insère que dans un sens. La pédale du seau à vadrouille doit être orientée vers le côté du socle comportant les leviers de frein des roues. (Voir Figure 2)

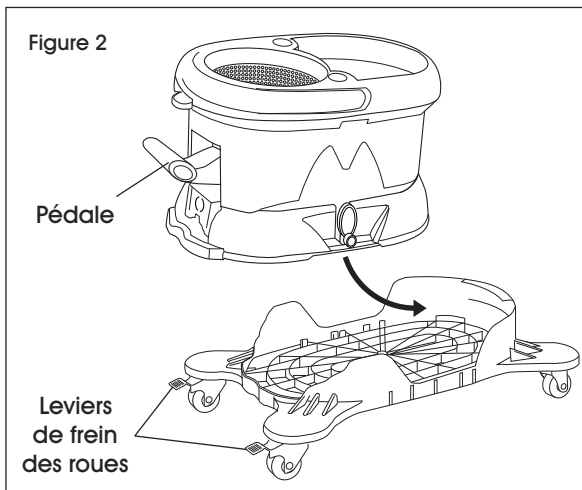

3. La configuration du seau à vadrouille et socle devrait ressembler à celle se trouvant à la figure ci-dessous. (Voir Figure 3)

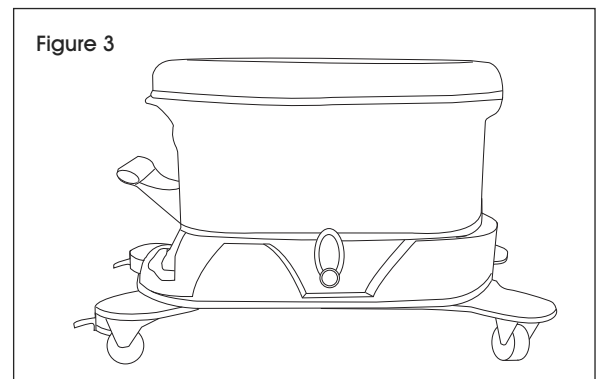

4. Pour bouger le socle, déverrouillez les roues en poussant les leviers de frein des roues vers le haut. (Voir Figure 4)

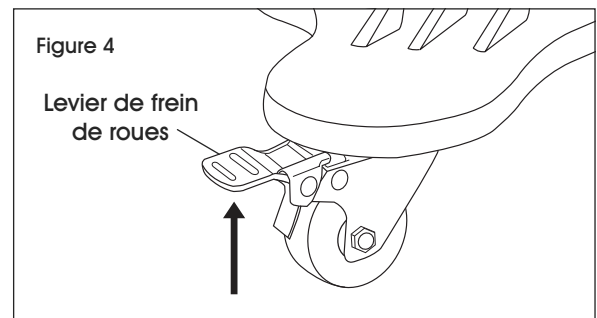

 **REMARQUE :** Pour de meilleurs résultats, verrouillez les roues avant d'essorer la vadrouille.