

# ULINE H-6577

## 8' DELUXE WOODEN PICNIC TABLE

1-800-295-5510  
uline.com

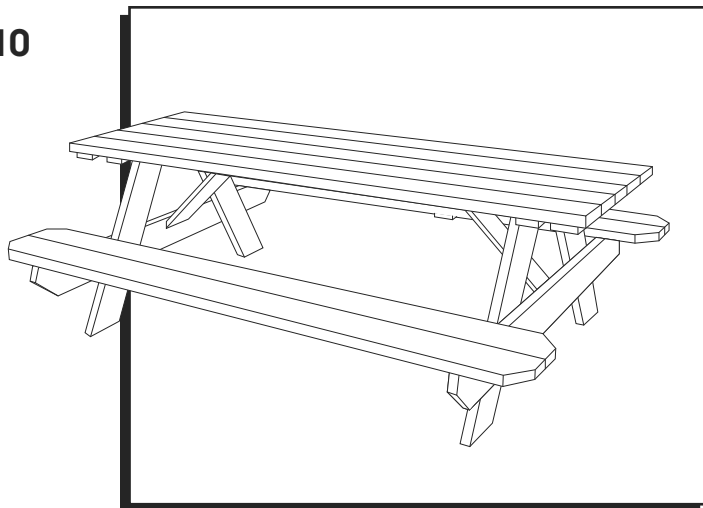

### TOOLS NEEDED



Drill

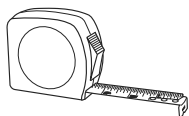

Tape Measure



Rubber Mallet

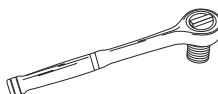

7/16" Socket Wrench

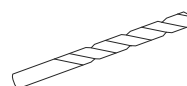

1/8" Drill Bit

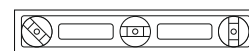

Level

### PARTS



Preassembled Table Top x 1

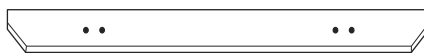

59" Pre-Drilled Seat Cross-Member x 2



96" Seat Plank x 4



Nut x 8



2 1/2" Wood Screw x 52

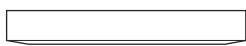

23 1/2" Diagonal Brace x 2



30" Pre-Drilled Table Leg x 4

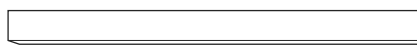

62" Seat Brace x 2



Washer x 8



3 1/2" Carriage Bolt x 8

### ASSEMBLY

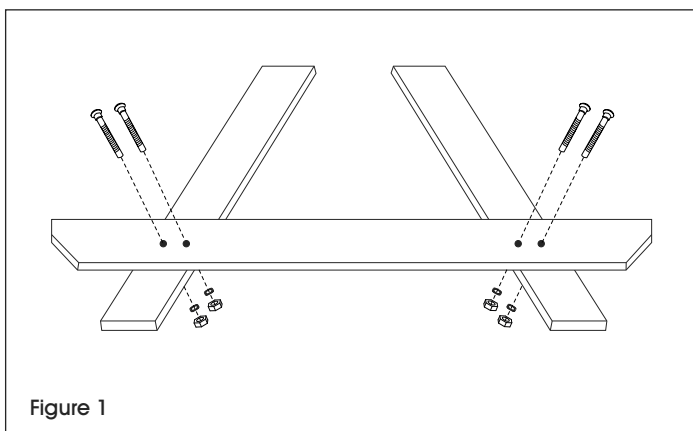

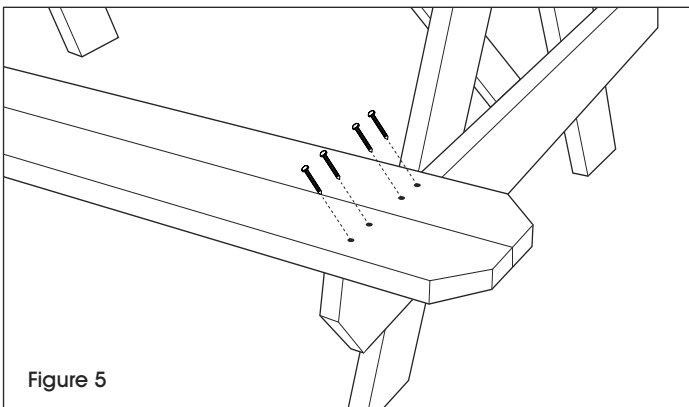
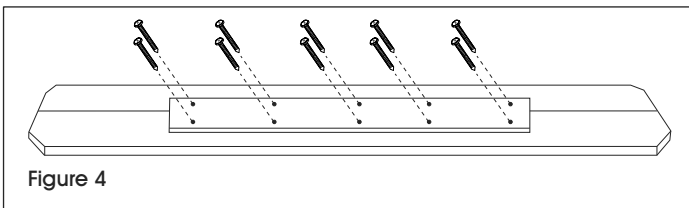
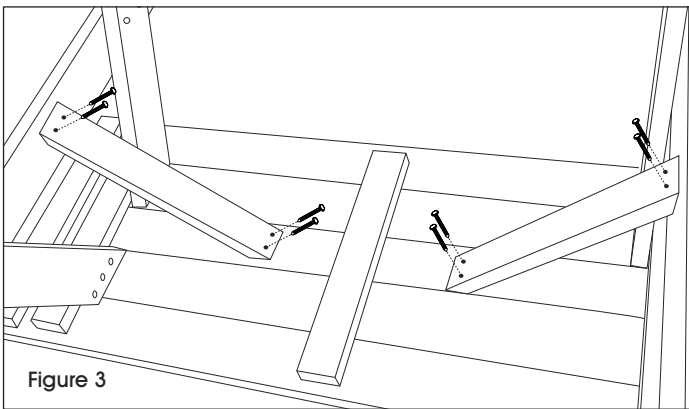
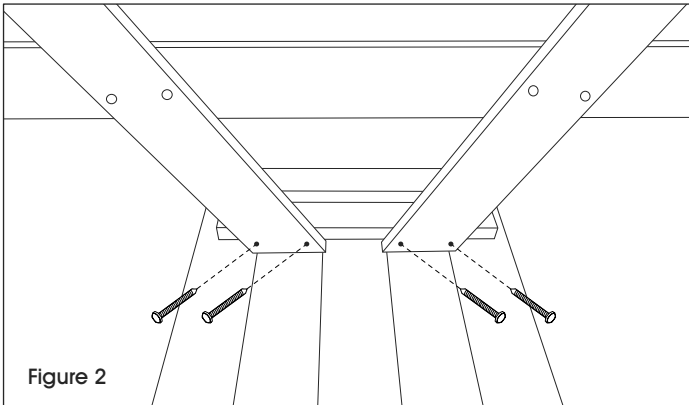

Figure 1

1. Verify all parts are present before beginning. Hardware is bagged and stapled to the table.
  2. Place the pre-drilled seat cross-member on top of the pre-drilled table legs. Position the legs so the holes are aligned and the tops of the legs are level and straight. (See Figure 1)
  3. Loosely attach with the 3 1/2" carriage bolts through the pre-drilled holes using the washers and nuts.
-  **NOTE:** It is recommended to use a rubber mallet to tap bolts through holes.
4. Repeat steps 1-3 for the second side.

## ASSEMBLY CONTINUED



5. Place the preassembled table top upside down. Position the legs on the inside of the support bar. Make sure the legs are equal distance from either table edge and the cross-member is facing out. (See Figure 2)
6. Pre-drill for holes using 1/8" drill bit. Loosely attach legs using four 2 1/2" wood screws through the pre-drilled holes. Repeat steps to attach the other leg.
7. Make sure the legs are perpendicular to the table top to ensure table top is level. Pre-drill and attach diagonal braces using four 2 1/2" wood screws to the cross-member and preassembled table top. (See Figure 3)
8. Flip the table so it is right side up.
9. Make sure legs are level and tighten all 3 1/2" carriage bolts using a 7/16" socket wrench. Tighten all 2 1/2" wood screws.
10. Attach a seat brace along the center of two seat planks ensuring the brace is equal distance from both ends of the seat. Pre-drill holes using 1/8" drill bit and attach using ten 2 1/2" wood screws on the brace. Repeat for the second seat plank. (See Figure 4)
11. Place the outside edge of the seat bench flush with the ends of the seat braces and align the ends of the bench with the edge of the table top. Use a 1/8" drill bit to pre-drill holes and avoid splitting. Attach the seat bench to the braces using eight 2 1/2" wood screws per bench seat. Repeat for opposite seat bench. (See Figure 5)

## CARE AND MAINTENANCE

1. Clean the table with a cleaner/brightener that contains mildewcide.
2. It is recommended to apply an outdoor wood sealer or stain that contains water repellent and an ultraviolet stabilizer.

**ULINE**

1-800-295-5510

uline.com

# ULINE H-6577

## MESA DE MADERA PARA PÍCNIC DE ALTA CALIDAD DE 8'

800-295-5510  
uline.mx

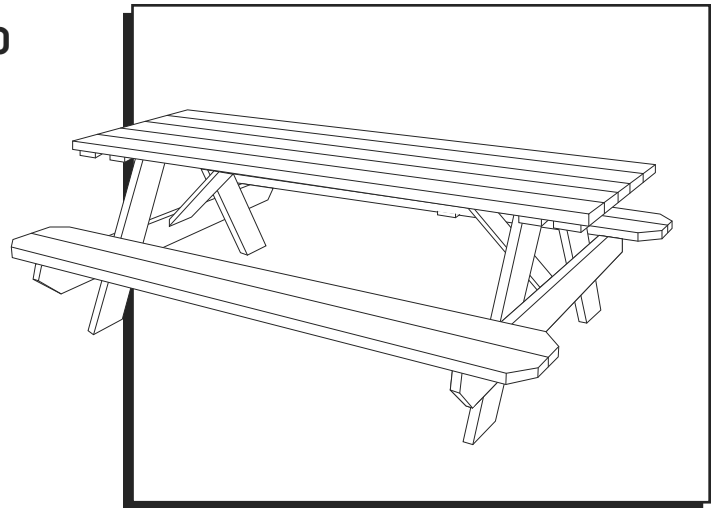

### HERRAMIENTAS NECESARIAS



Taladro

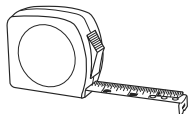

Cinta de Medir



Mazo de Caucho

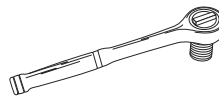

Llave de Dado de 7/16"

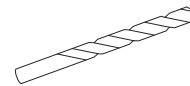

Broca de Taladro  
de 1/8"

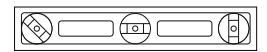

Nivel

### PARTES

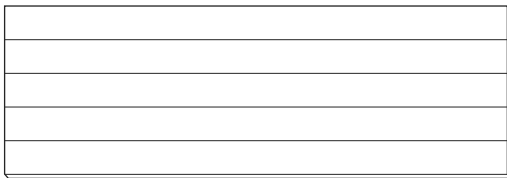

1 Cubierta Preensamblada de Mesa



2 Travesaños Preperforados de 59" para el Asiento

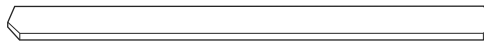

4 Tablas para el Asiento de 96"



8 Tuercas



52 Tornillos de 2 1/2"  
para Madera

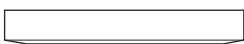

2 Soportes Diagonales de 23 1/2"

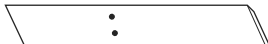

4 Patas Preperforadas  
de 30" para la Mesa

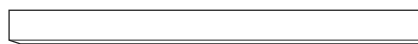

2 Soportes para el Asiento de 62"



8 Rondanas

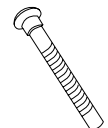

8 Pernos de 3 1/2"

### ENSAMBLE



Diagrama 1

1. Verifique que tenga todas las partes antes de comenzar. La tornillería está en una bolsa engrapada a la mesa.
2. Coloque el travesaño para el asiento preperforado sobre las patas preperforadas. Coloque las patas de forma que los orificios estén alineados y la parte superior de las patas estén niveladas y rectas. (Vea Diagrama 1)
3. Fije con los pernos de 3 1/2" a través de los orificios preperforados usando las rondanas y las tuercas, sin apretarlas.

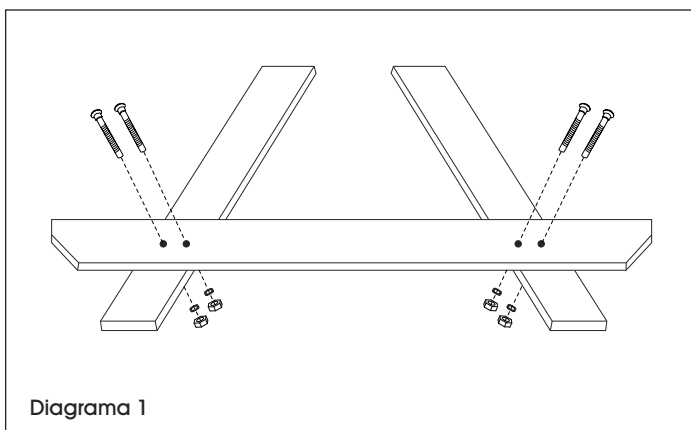

**NOTA:** Se recomienda usar un mazo de caucho para pasar los pernos por los orificios.

4. Repita los pasos 1-3 con el segundo lado.

## CONTINUACIÓN DE ENSAMBLE



Diagrama 2



Diagrama 3

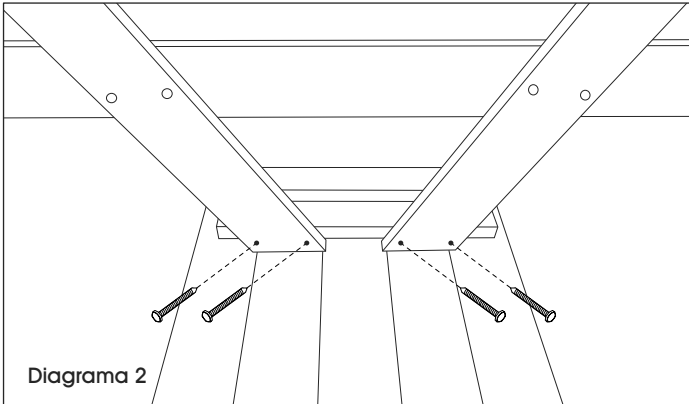

Diagrama 4

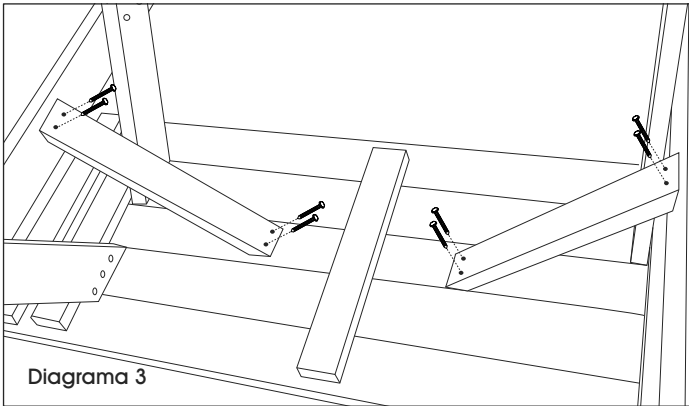

Diagrama 5

5. Coloque en posición invertida la cubierta de mesa preensamblada. Coloque las patas en el interior de la barra de soporte. Asegúrese de que las patas estén a la misma distancia de ambos extremos de la mesa y que el travesaño voltee hacia afuera. (Vea Diagrama 2)
6. Preperfore los orificios utilizando una broca de 1/8". Fije las patas con cuatro tornillos de 2 1/2" para madera, sin apretar, a través de los orificios preperforados. Repita los pasos para fijar la otra pata.
7. Verifique que las patas estén perpendiculares a la cubierta de la mesa para asegurarse de que la cubierta esté nivelada. Preperfore y fije los soportes diagonales a los travesaños y a la cubierta preensamblada para la mesa usando cuatro tornillos de 2 1/2" para madera. (Vea Diagrama 3)
8. Voltee la mesa a su posición correcta.
9. Asegúrese de que las patas están niveladas y apriete todos los pernos de 3 1/2" utilizando la llave de dado de 7/16". Apriete todos los tornillos de 2 1/2" para madera.
10. Fije un soporte para asiento a lo largo del centro de dos tablas para asiento, asegúrese de que el soporte esté a la misma distancia de ambos extremos del asiento. Preperfore los orificios utilizando una broca de 1/8" y fije al soporte utilizando diez tornillos de 2 1/2" para madera. Repita con la segunda tabla para asiento. (Vea Diagrama 4)
11. Coloque el borde exterior del asiento de la banca al ras con los extremos de los soportes del asiento y alinee los extremos de la banca con el borde de la cubierta de la mesa. Utilice una broca de 1/8" para preperforar los orificios y evitar que se separen. Fije el asiento de la banca a los soportes usando ocho tornillos de 2 1/2" para madera por cada asiento de la banca. Repita con el asiento de la banca opuesta. (Vea Diagrama 5)

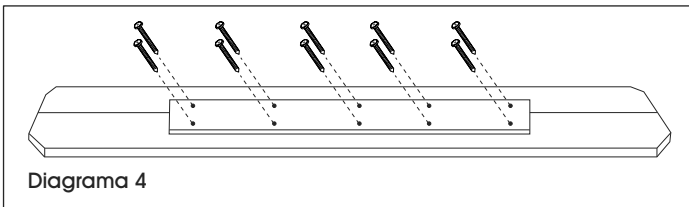
## CUIDADO Y MANTENIMIENTO

1. Limpie la mesa con un limpiador/abrillantador que contenga anti-moho.
2. Se recomienda que aplique un sellador o tintura para madera de exteriores que contenga repelente al agua y un estabilizador de rayos ultravioleta

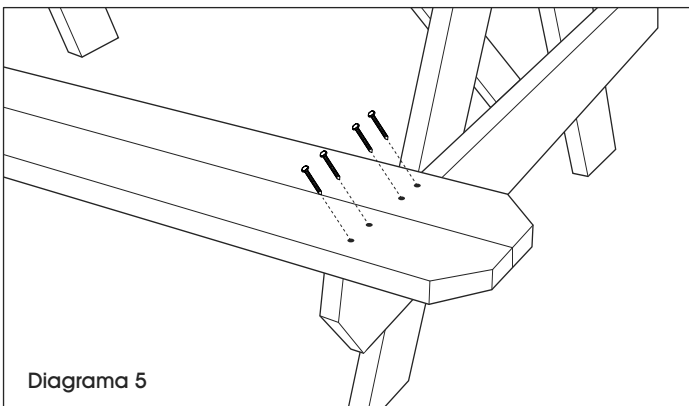
**ULINE**

800-295-5510  
uline.mx

**ULINE** H-6577

# TABLE DE PIQUE-NIQUE DE LUXE EN BOIS – 8 PI

1-800-295-5510

uline.ca

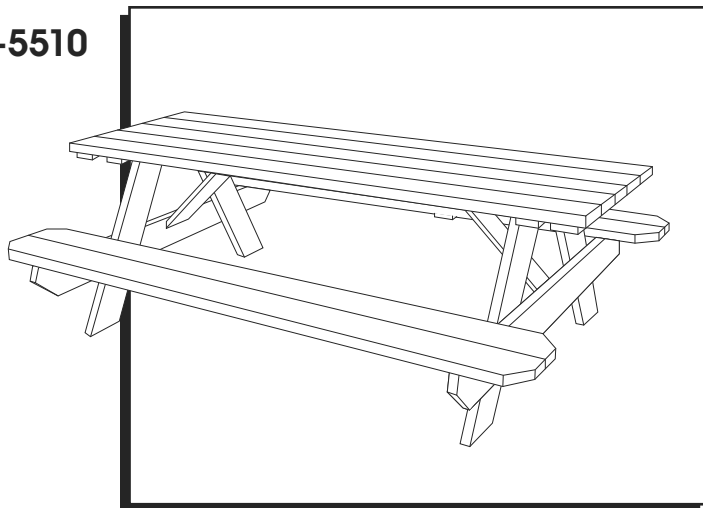

## OUTILS REQUIS



Perceuse

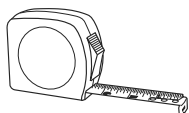

Ruban à mesurer



Maillet en caoutchouc

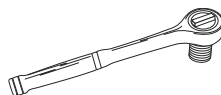

Clé à douilles de 7/16 po

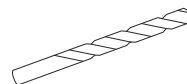

Mèche de perceuse de 1/8 po



Niveau

## PIÈCES



Dessus de table préassemblé x 1

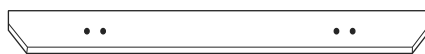

Traverse de banc préperçée de 59 po x 2



Planche de banc de 96 po x 4



Écrou x 8

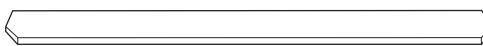

Vis à bois de 2 1/2 po x 52

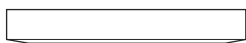

Renfort de soutien diagonal de 23 1/2 po x 2

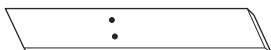

Patte de table préperçée de 30 po x 4

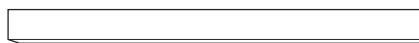

Barre de renfort de banc de 62 po x 2



Rondelle x 8



Boulon de carrosserie de 3 1/2 po x 8

## MONTAGE

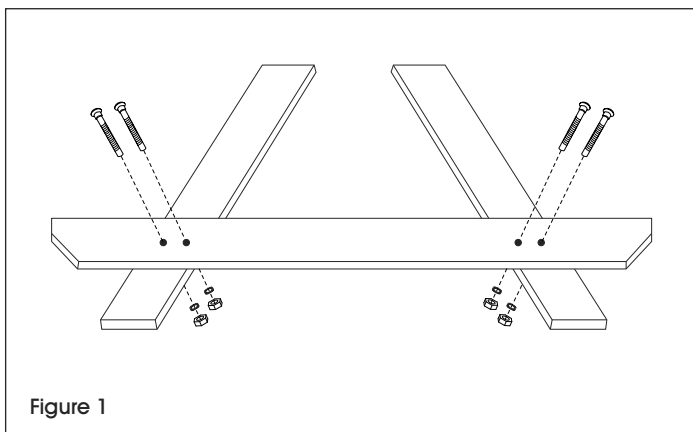

Figure 1

1. Assurez-vous que toutes les pièces sont présentes avant de commencer. Le matériel d'installation se trouve dans un sac agrafé à la table.
2. Placez la traverse de banc préperçée au-dessus des pattes préperçées de la table. Positionnez les pattes de façon à ce que les trous soient alignés et que la partie supérieure des pattes soit de niveau et droite. (Voir Figure 1)
3. Fixez lâchement les boulons de carrosserie de 3 1/2 po à travers les trous préperçés à l'aide des rondelles et des écrous.



**REMARQUE :** Il est recommandé d'utiliser un maillet en caoutchouc pour insérer les boulons dans les trous.

4. Répétez l'opération pour la deuxième patte.

## MONTAGE SUITE

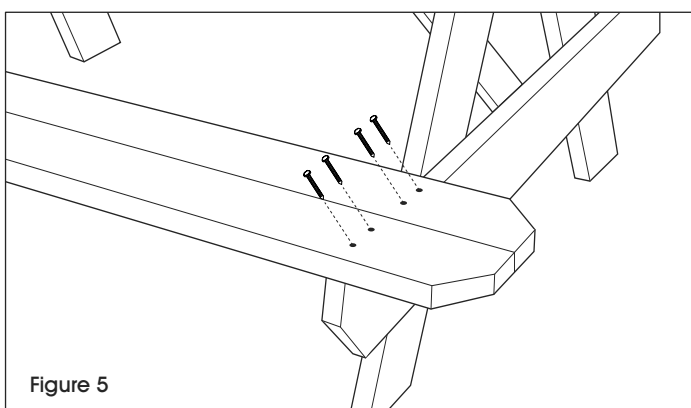
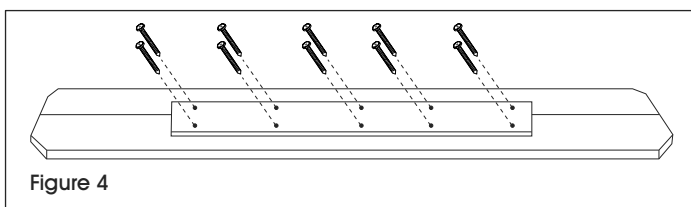
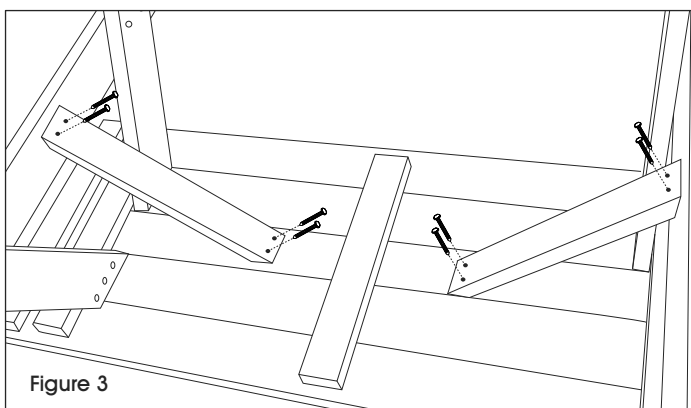
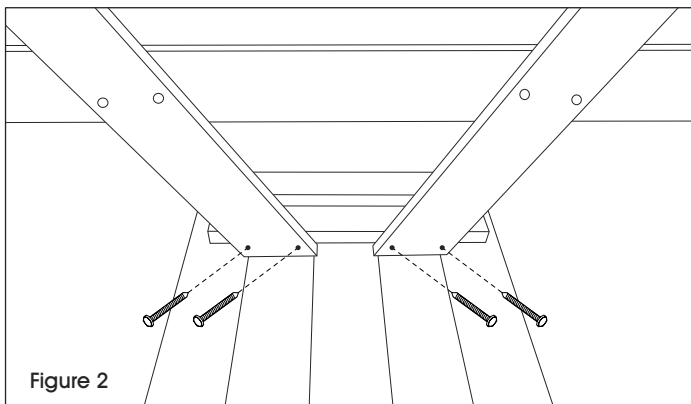

5. Placez le dessus de table préassemblé à l'envers. Placez les pattes sur la face intérieure de la barre de soutien. Assurez-vous que les pattes sont équidistantes des deux bords de la table et que la traverse est orientée vers l'extérieur. (Voir Figure 2)
6. Prépercez quatre trous en utilisant une mèche de perceuse de 1/8 po. Fixez lâchement les pattes à l'aide de quatre vis à bois de 2 1/2 po en les insérant à travers les trous préperçés. Répétez les étapes pour fixer l'autre patte.
7. Assurez-vous que les pattes sont perpendiculaires au dessus de table pour que le dessus de table soit bien de niveau. Prépercez des trous et fixez les renforts de soutien diagonaux à l'aide de quatre vis à bois de 2 1/2 po sur la traverse et le dessus de table préassemblé. (Voir Figure 3)
8. Retournez la table.
9. Assurez-vous que les pattes sont de niveau et serrez tous les boulons de carrosserie de 3 1/2 po à l'aide de la clé à douilles de 7/16 po. Serrez toutes les vis à bois de 2 1/2 po.
10. Fixez une barre de renfort au long du centre de deux planches de banc en vous assurant qu'elle est équidistante des deux extrémités du siège. Prépercez les trous en utilisant une mèche de perceuse de 1/8 po et fixez la barre de renfort avec dix vis à bois de 2 1/2 po. Répétez pour la deuxième planche de banc. (Voir Figure 4)
11. Placez le bord extérieur du banc à ras avec les extrémités des renforts de soutien du banc et alignez les extrémités du banc avec le bord du dessus de table. Utilisez une mèche de perceuse de 1/8 po pour éviter que le bois ne se fende. Fixez le banc aux renforts de soutien à l'aide de huit vis à bois de 2 1/2 po pour chaque banc. Répétez l'opération pour l'autre banc. (Voir Figure 5)

## NETTOYAGE ET ENTRETIEN

1. Nettoyez la table à l'aide d'un détergent/azurant contenant un agent antimoisissure.
2. Il est recommandé d'appliquer un apprêt pour bois extérieur hydrofuge et anti-UV.

**ULINE**

1-800-295-5510

uline.ca