

# ULINE H-6842, H-7443 ALUMINUM U-BOAT PLATFORM TRUCK

1-800-295-5510  
uline.com

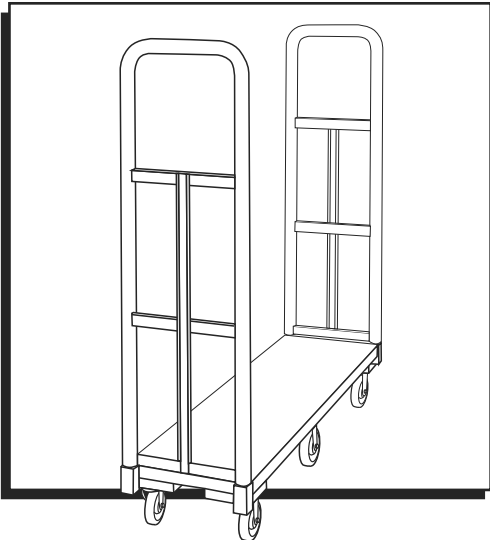

## TOOLS NEEDED



1/2" Wrench



9/16" Wrench

## PARTS



Small Washer x 20



Large Washer x 8



Small Lock Washer x 16



Large Lock Washer x 8

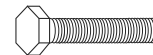

Long Hex Bolt for  
Handle x 4



Swivel Caster x 4

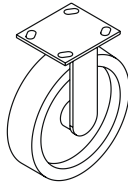

Large Center Caster x 2



Small Nut x 16



Large Nut x 4

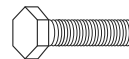

Short Hex Bolt for  
Center Caster x 4

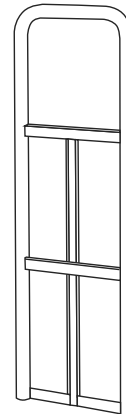

Handle x 2

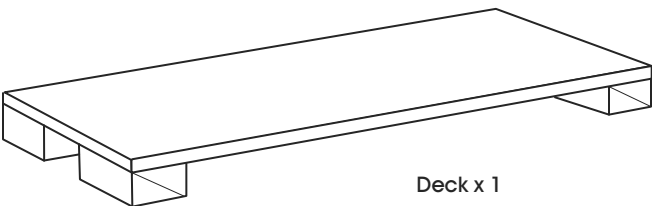

Deck x 1

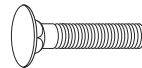

Small Carriage Bolt  
x 16

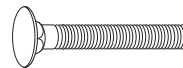

Large Carriage Bolt  
x 4

## ASSEMBLY

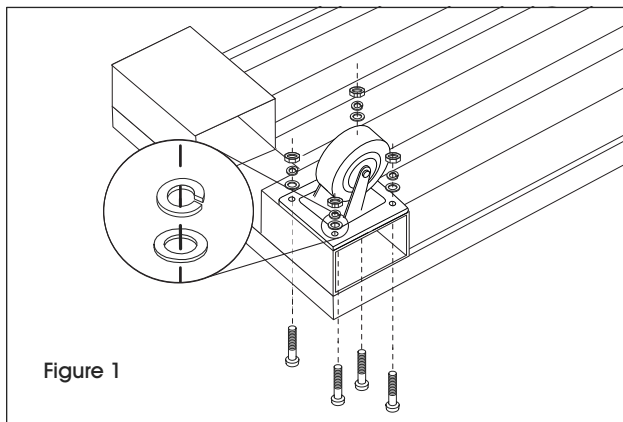
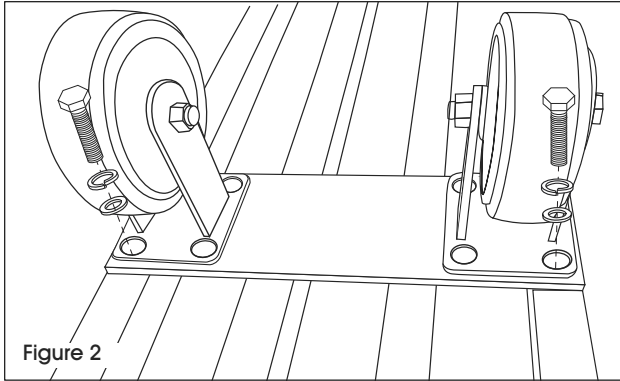

Figure 1

1. Place deck on a smooth, non-marring surface with top side down. Mount swivel casters to deck with small carriage bolts, small nuts, small lock washers and small washers. (See Figure 1)

## ASSEMBLY



2. Mount large center casters to outer sides of deck with short hex bolts, large lock washers and large washers. Insert bolts down into deck. (See Figure 2)

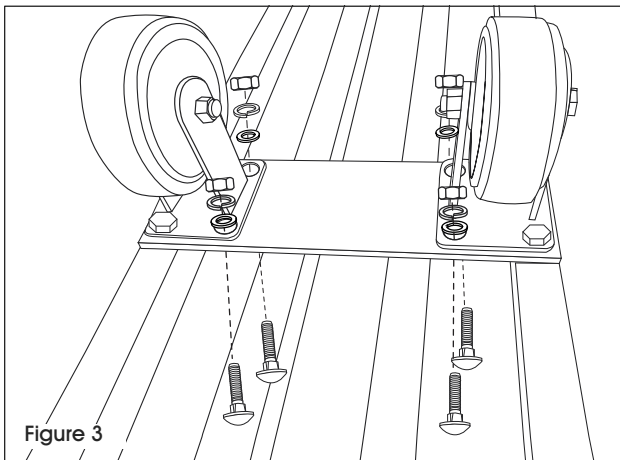

3. Use large carriage bolts, large washers, large lock washers and large nuts to finish mounting the large center casters. Insert bolts from underneath channel, up through the caster plate. (See Figure 3)

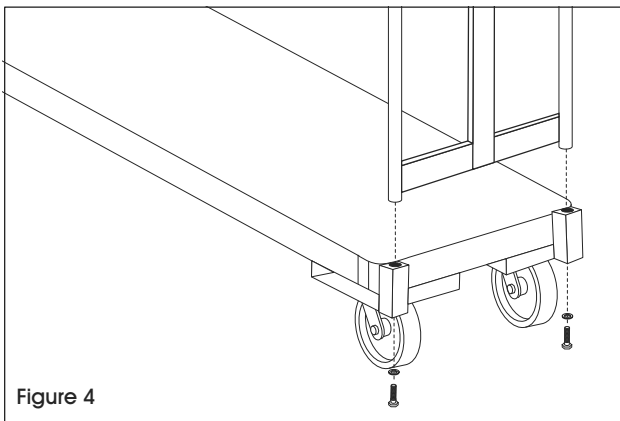

4. Turn the deck over onto its casters and insert the handle into the sockets. Vertical support on handle should face the outside of the truck. Secure the handles into the sockets by inserting the long hex bolts and small washers from underneath the sockets. (See Figure 4)

**ULINE**

1-800-295-5510  
uline.com

**ULINE** H-6842, H-7443

# CARRITOS DE PLATAFORMA EN U DE ALUMINIO

800-295-5510  
uline.mx

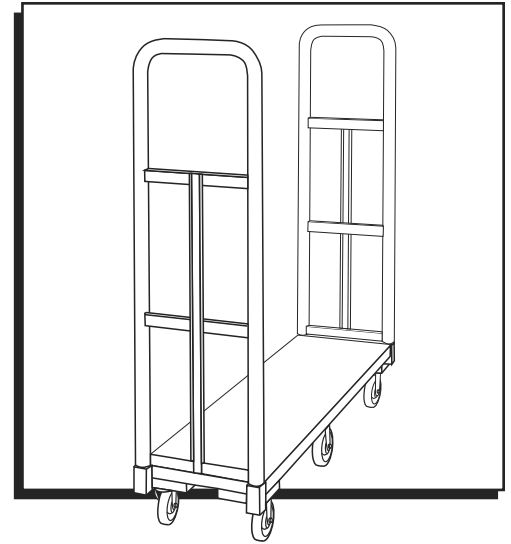

## HERRAMIENTAS NECESARIAS



Llave de 1/2"



Llave de 9/16"

## PARTES



20 Rondanas Pequeñas



8 Rondanas Grandes



16 Rondanas de Bloqueo Pequeñas



8 Rondanas de Bloqueo Grandes

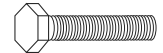

4 Pernos Hexagonales Largos para Asas



4 Ruedas Giratorias

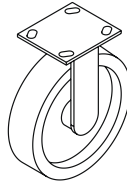

2 Ruedas Centrales Grandes



16 Tuercas Pequeñas



4 Tuercas Grandes

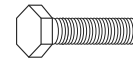

4 Pernos Hexagonales Cortos para Ruedas Centrales

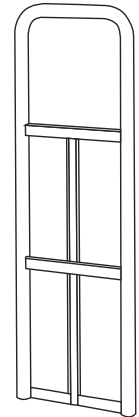

2 Asas

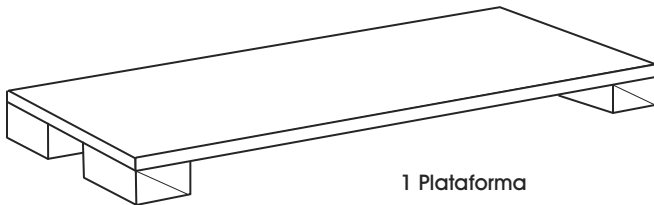

1 Plataforma

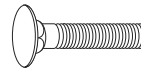

16 Pernos Pequeños de Cabeza Redonda

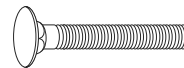

4 Pernos Grandes de Cabeza Redonda

## ENSAMBLE



Diagrama 1

1. Coloque la plataforma sobre una superficie lisa que no deje marcas, con el lado superior hacia abajo. Instale las ruedas giratorias a la plataforma con los pernos de cabeza redonda, tuercas pequeñas, rondanas y rondanas de bloqueo pequeñas. (Vea Diagrama 1)

## ENSAMBLE

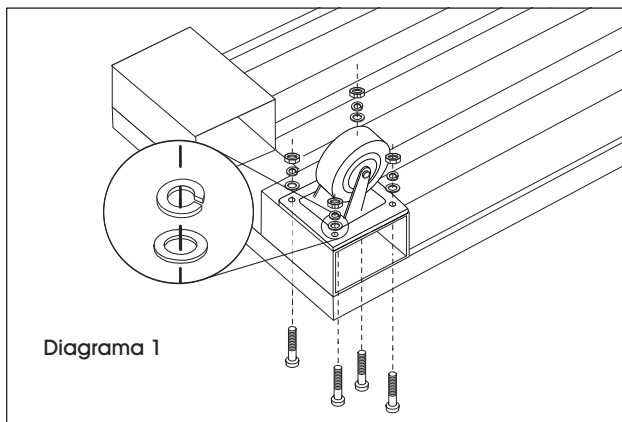
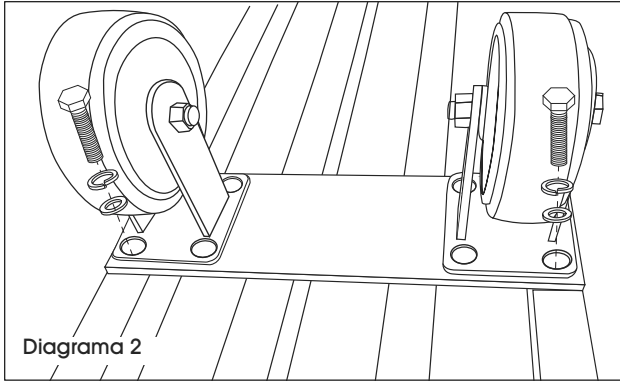

2. Instale las ruedas centrales grandes en los extremos de la plataforma con los pernos hexagonales pequeños, rondanas de bloqueo grandes y rondanas grandes. Inserte los pernos en la plataforma. (Vea Diagrama 2)

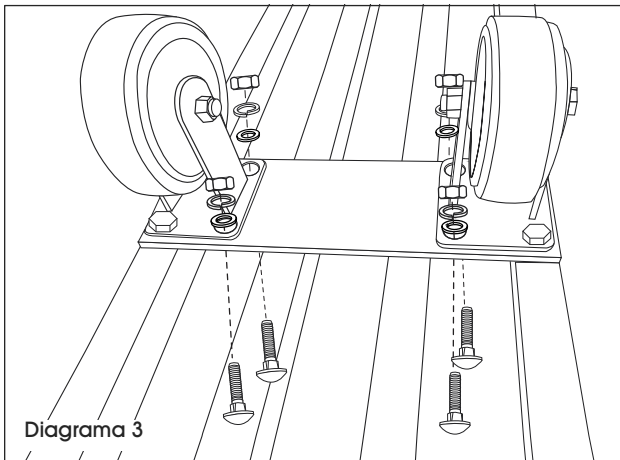

3. Utilice pernos grandes de cabeza redonda, rondanas grandes, rondanas de bloqueo grandes y tuercas grandes para terminar de instalar las ruedas centrales grandes. Inserte los pernos desde abajo del canal, hacia arriba atravesando la placa de la rueda. (Vea Diagrama 3)

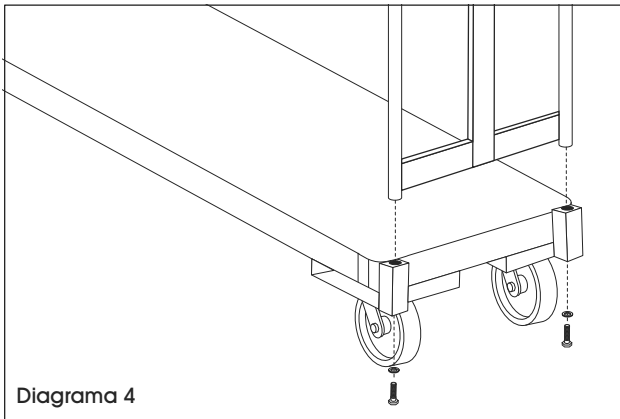

4. Voltee la placa de manera que quede sobre las ruedas e inserte el asa en las cavidades. El soporte vertical del asa debe quedar hacia el exterior del carrito. Fije las asas en los orificios instalando los pernos hexagonales grandes y las rondanas pequeñas desde la parte de abajo de las cavidades. (Vea Diagrama 4)

**ULINE**

800-295-5510  
uline.mx

**ULINE** H-6842, H-7443

1-800-295-5510

uline.ca

# CHARIOT À PLATEFORME U-BOAT EN ALUMINIUM

## OUTILS REQUIS



Clé de 1/2 po



Clé de 9/16 po

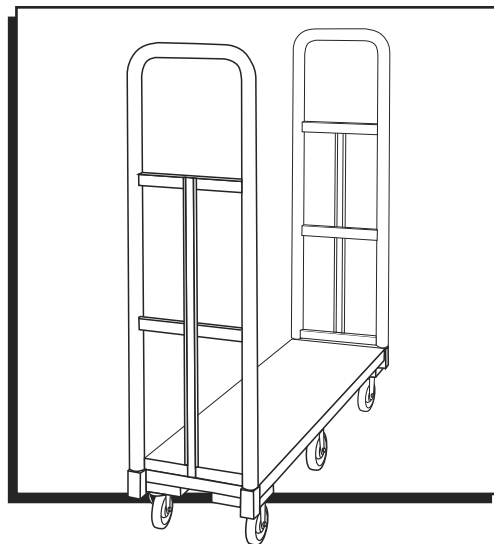

## PIÈCES



Petite rondelle x 20



Grande rondelle x 8



Petite rondelle de blocage  
x 16



Grande rondelle de  
blocage x 8

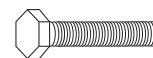

Long boulon à tête  
hexagonale pour  
poignée x 4



Roulette pivotante x 4

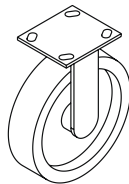

Grande roulette centrale x 2



Petit écrou x 16



Grand écrou x 4

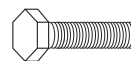

Court boulon à tête  
hexagonale pour  
roulette centrale x 4

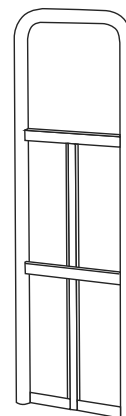

Poignée x 2

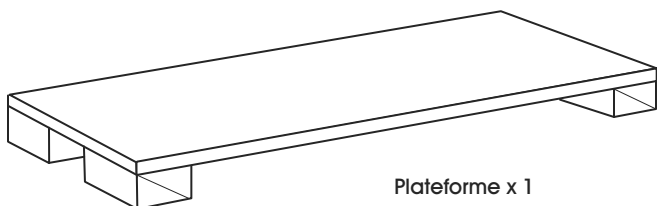

Plateforme x 1

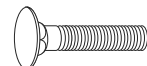

Petit boulon de  
carrosserie x 16

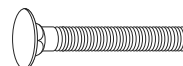

Grand boulon de  
carrosserie x 4

## MONTAGE

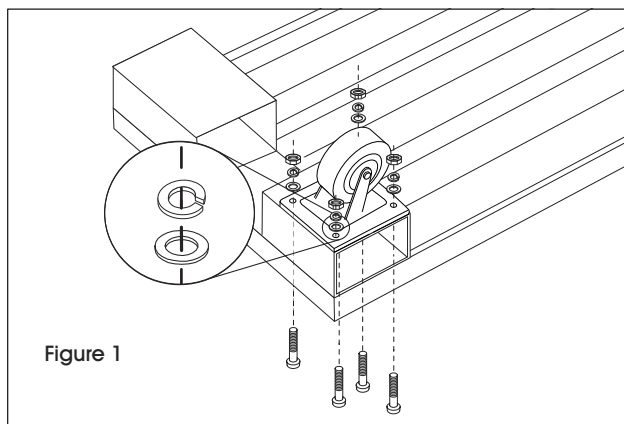

Figure 1

1. Placez la plateforme sur une surface lisse non marquante, avec la face supérieure orientée vers le bas. Fixez les roulettes pivotantes sur la plateforme avec les petits boulons de carrosserie, les petits écrous, les petites rondelles de blocage et les petites rondelles. (Voir Figure 1)

## MONTAGE

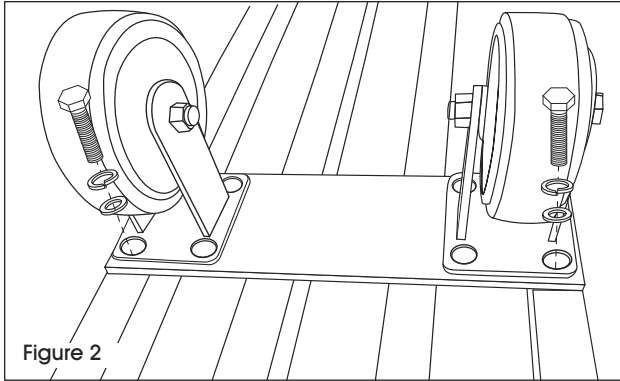

Figure 2

2. Fixez les grandes roulettes centrales de chaque côté extérieur de la plateforme à l'aide des courts boulons à tête hexagonale, des grandes rondelles de blocage et des grandes rondelles. Insérez les boulons dans la plateforme. (Voir Figure 2)

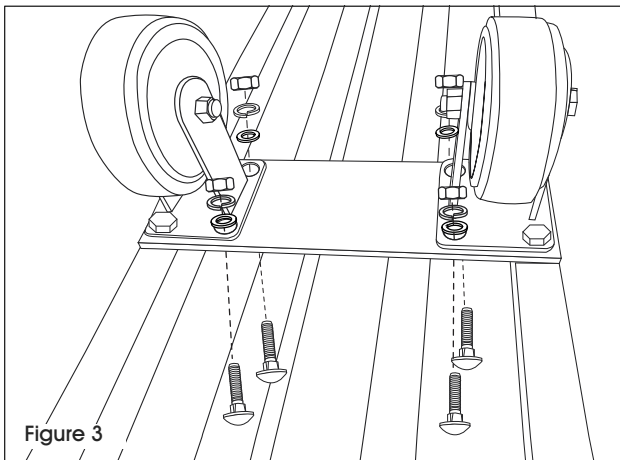

Figure 3

3. Utilisez les grands boulons de carrosserie, les grandes rondelles, les grandes rondelles de blocage et les grands écrous pour terminer l'installation des grandes roulettes centrales. Insérez les boulons par dessous et à travers les supports de roulettes. (Voir Figure 3)

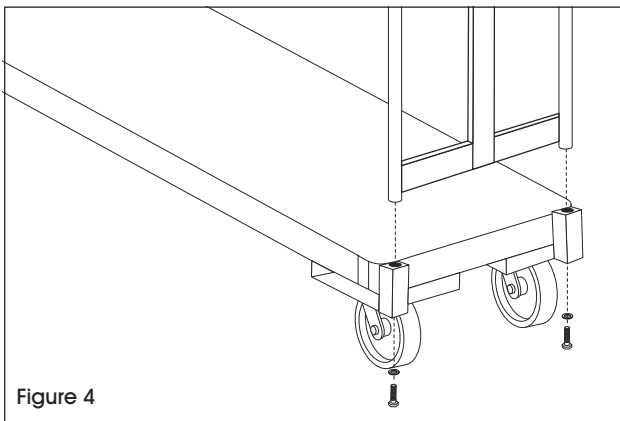

Figure 4

4. Retournez la plateforme sur ses roulettes et insérez la poignée dans les trous prévus à cet effet. Le support vertical sur la poignée doit faire face à l'extérieur du chariot. Fixez les poignées dans les trous en insérant les longs boulons à tête hexagonale et les petites rondelles par dessous les trous. (Voir Figure 4)

**ULINE**

1-800-295-5510  
uline.ca