

ULINE

OFFICE CREDENZA OR L-DESK WITH HUTCH

1-800-295-5510
uline.com

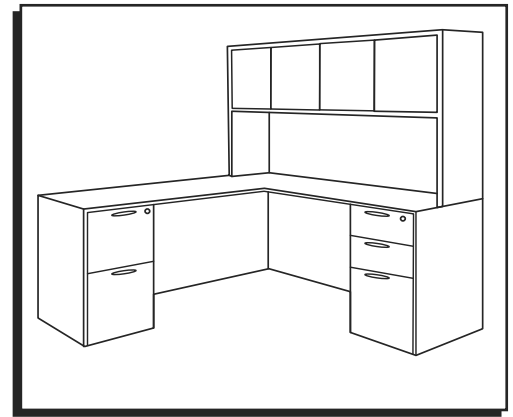

TOOLS NEEDED



Phillips
Screwdriver

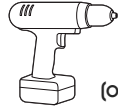

Drill
(optional)



Two Person Assembly
Recommended



STOP: If assembling U-Desk with Hutch, refer to instructions included with H-6855 72 x 36" Desk Shell.

DESK/CREDENZA SHELL ASSEMBLY PARTS LIST

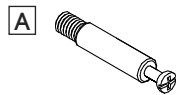

Camlock Pin x 14



Camlock x 14

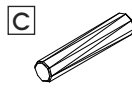

Dowel x 11



Glide x 4

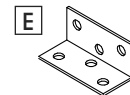

L-Bracket x 5

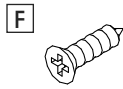

Screw x 35
#4 x 5/8"



Grommet
Cap x 2

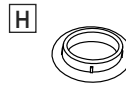

Deep Camlock
Cap x 5

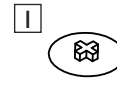

Camlock
Cap x 9

DESK/CREDENZA SHELL ASSEMBLY INSTRUCTIONS

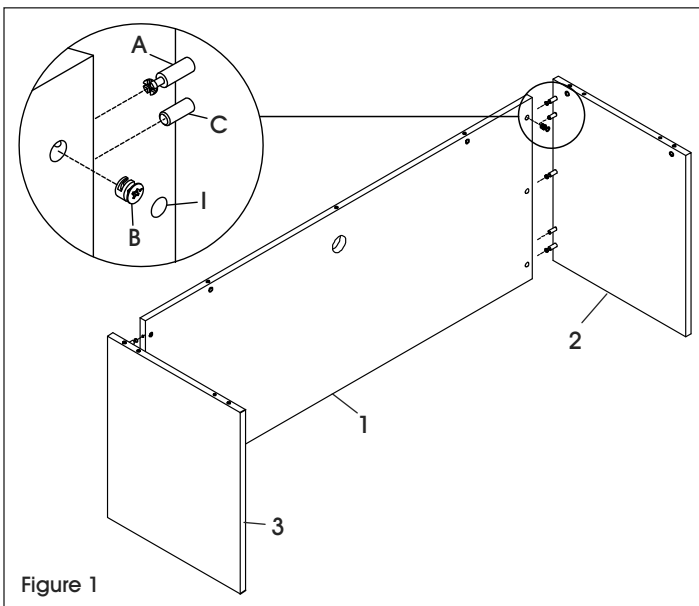

NOTE: Credenza shell will be used as the main desk for the L-Desk with Hutch.

NOTE: Assemble unit on a smooth, non-marring surface to prevent scratching. Check that you have all parts listed.

1. Insert camlocks (B) into back panel (1). Insert camlock pins (A) and dowels (C) into side panels (2 and 3). Attach panels and tighten camlocks using a Phillips head screwdriver. (See Figure 1)

IMPORTANT: Turn cam lock 1/4 turn to the right to lock. Ensure the arrow is pointing to edge of panel before inserting into the panel's hole.

IMPORTANT: Function of Cam



NOTE: Camlock caps can be applied once camlocks are tightened for a finished look.

DESK/CREDENZA SHELL ASSEMBLY INSTRUCTIONS

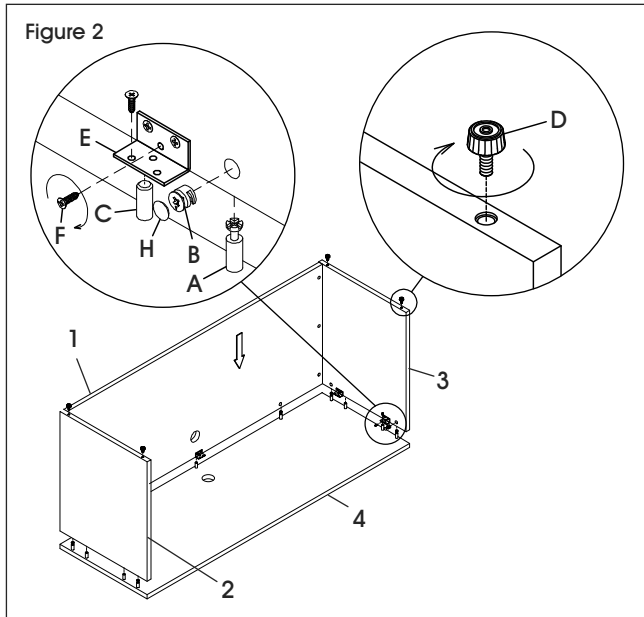

2. Insert camlocks (B) into side panels (2 and 3). Insert camlock pins (A) and dowels (C) into top panel (4). Attach panels and tighten camlocks using a Phillips head screwdriver. (See Figure 2)
3. Use L-Brackets (E) to connect back panel (1) and top panel (4). Attach using #4 x 5/8" screws (F). For additional stability, L-Brackets can be installed to connect side panels (2 and 3) to top panel (4), but only do so if pedestals will not be installed. (See Figure 2)
4. Insert glides (D) into side panels (2 and 3). (See Figure 2)

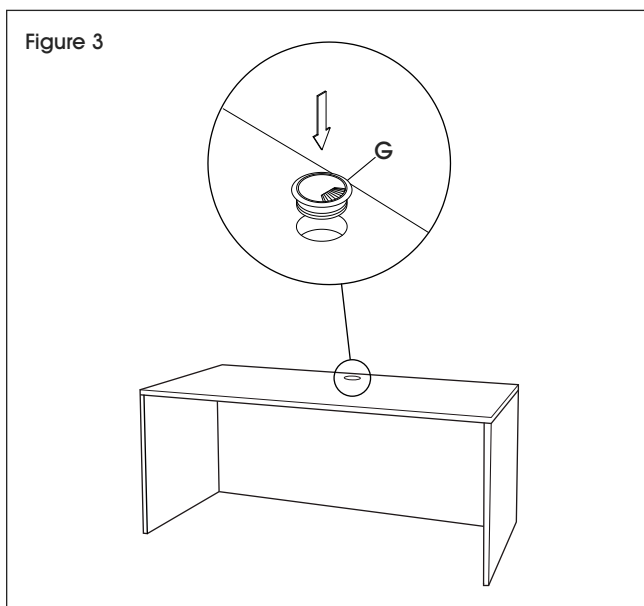

5. Insert grommet caps (G) into top and back panel. (See Figure 3)



STOP: For Office Credenza assembly, proceed to Pedestal Assembly on page 6. For L-Desk with Hutch assembly, proceed to L-Desk Return Assembly on page 3.

L-DESK RETURN ASSEMBLY PARTS LIST

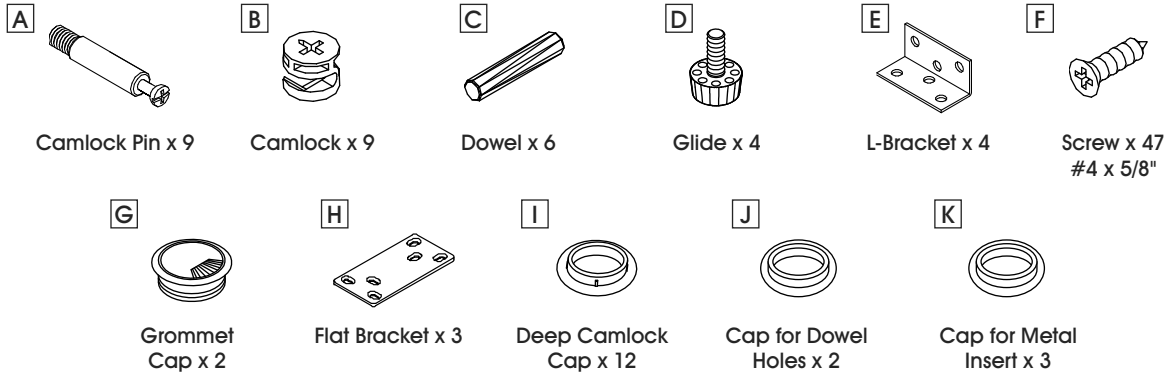

L-DESK RETURN ASSEMBLY INSTRUCTIONS

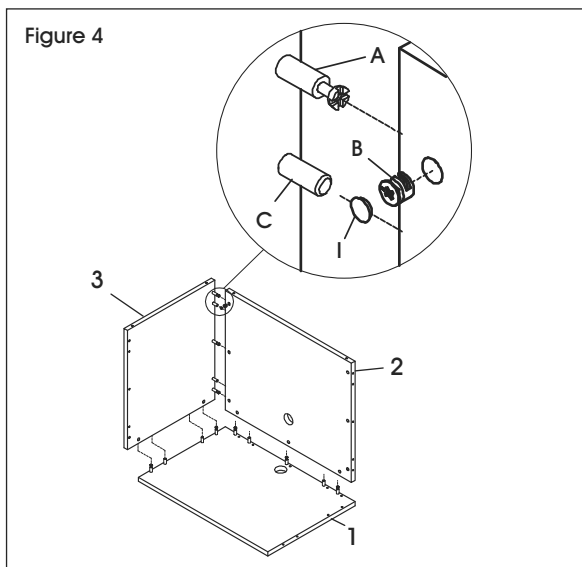

1. Insert camlocks (B) into back panel (2) and side panel (3). Insert camlock pins (A) and dowels (C) into top panel (1) and side panel (3). Attach panels and tighten camlocks using a Phillips head screwdriver. (See Figure 4)

 **NOTE:** Diagram shows right-hand L-Desk configuration. For left-hand L-Desk configuration, flip side panel to opposite side.

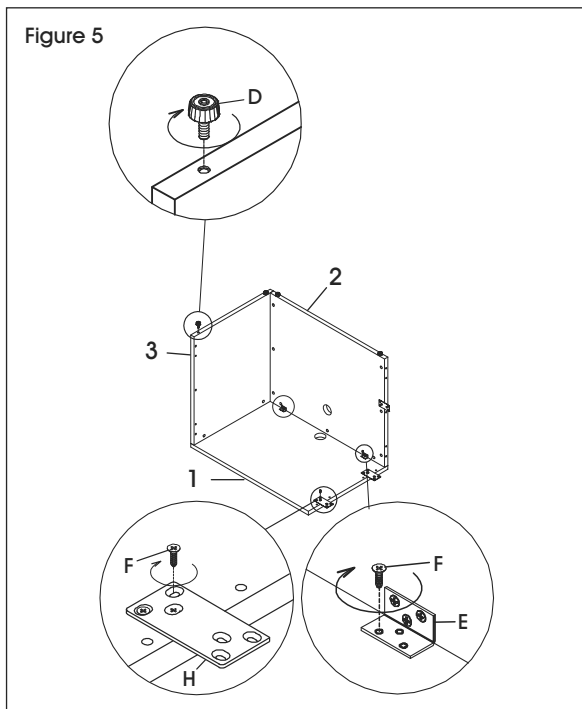

2. Insert glides (D) into back panel (2) and side panel (3). (See Figure 5)
3. Use L-Brackets (E) to connect top panel (1) and back panel (2). Attach using #4 x 5/8" screws (F). (See Figure 5)

 **NOTE:** If installing a pedestal, L-Brackets are not required to connect top panel and side panel.

4. Attach one end of flat brackets (H) to the top panel (1) and back panel (2) using #4 x 5/8" screws (F). (See Figure 5)

L-DESK RETURN ASSEMBLY INSTRUCTIONS CONTINUED

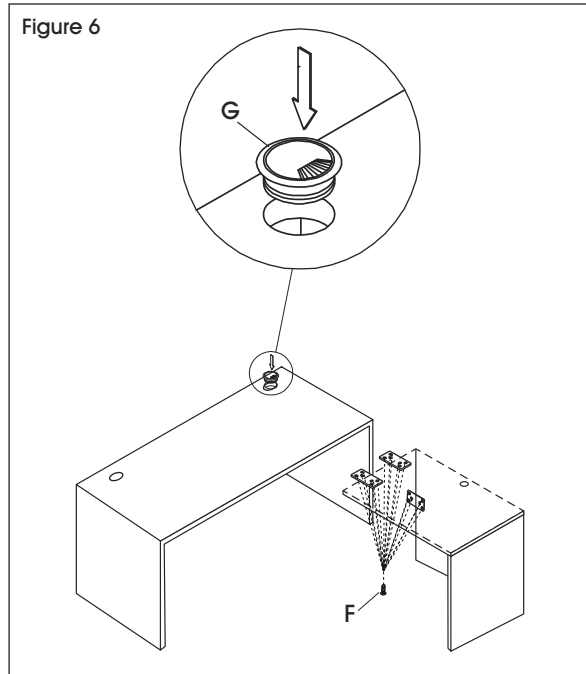

- Carefully flip over return and attach other end of flat brackets to the underside of the desk/credenza shell using #4 x 5/8" screws (F). (See Figure 6)
- Insert grommet caps (G) into top and back panel. (See Figure 6)

L-DESK HUTCH ASSEMBLY PARTS LIST

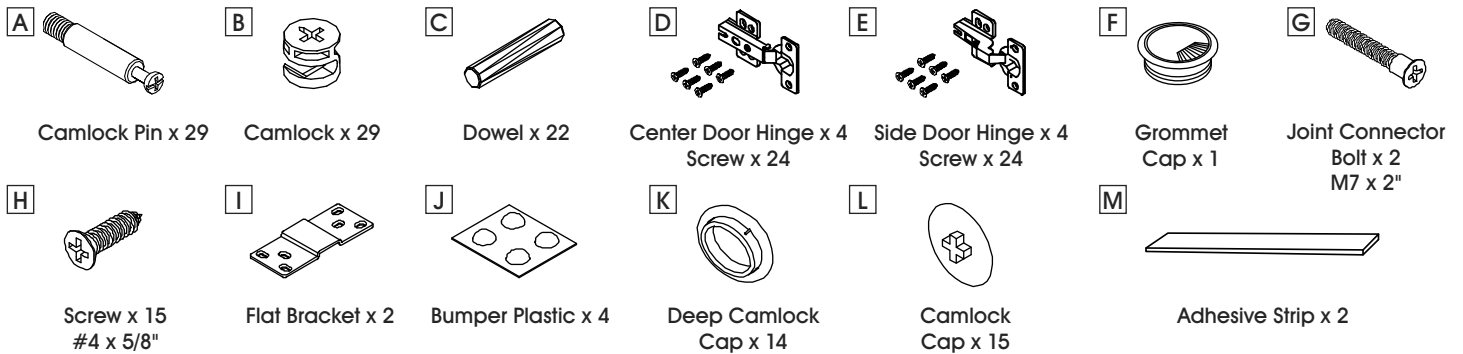

L-DESK HUTCH ASSEMBLY INSTRUCTIONS

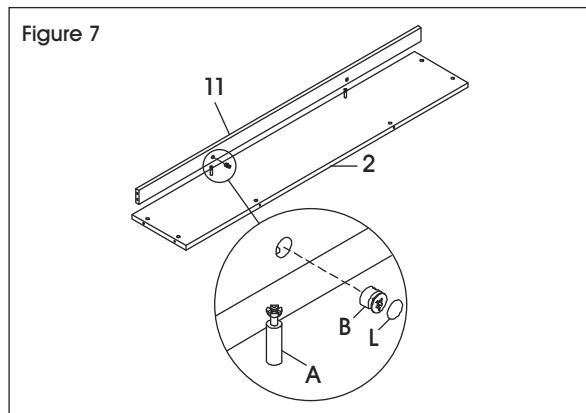

- Insert camlocks (B) into skirt panel (11). Insert camlock pins (A) into shelf panel (2). Attach panels and tighten camlocks using a Phillips head screwdriver. (See Figure 7)

L-DESK HUTCH ASSEMBLY INSTRUCTIONS CONTINUED

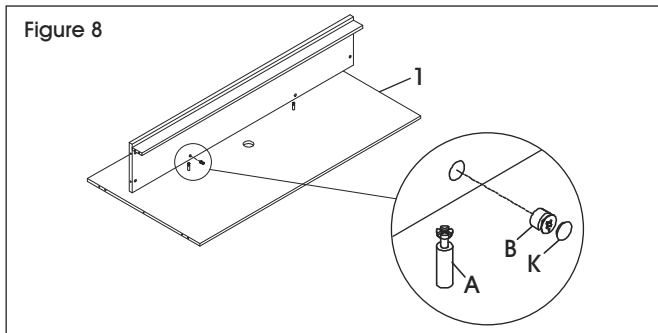

2. Insert camlocks (B) into shelf panel. Insert camlock pins (A) into back panel (1). Attach panels and tighten camlocks using a Phillips head screwdriver. (See Figure 8)

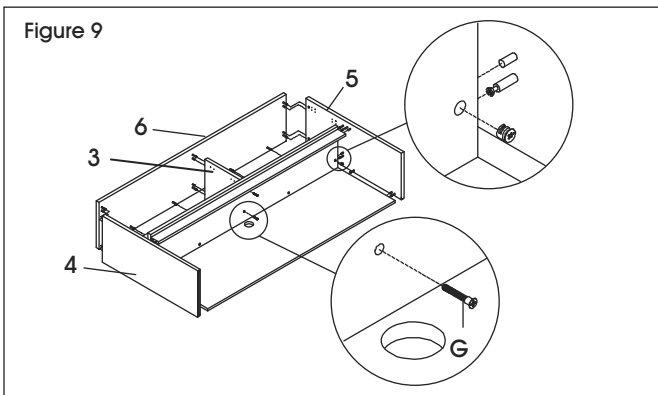

3. Insert camlocks (B), camlock pins (A) and dowels (C) into remaining panels. Attach all panels and tighten camlocks using a Phillips head screwdriver. (See Figure 9)

 **NOTE:** Do not tighten joint connector bolt (G) until top panel is installed.

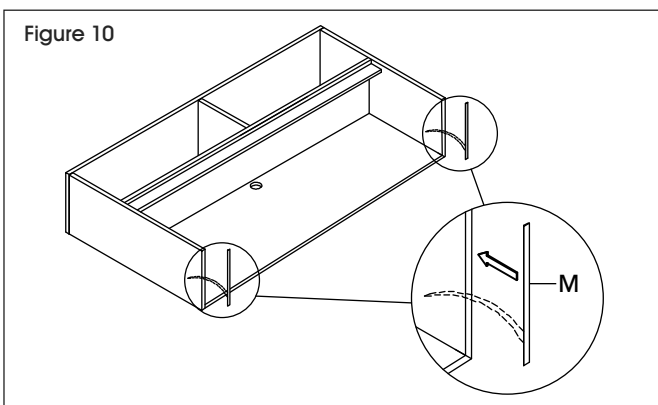

4. Apply adhesive strips (M) to bottom of hutch. (See Figure 10)

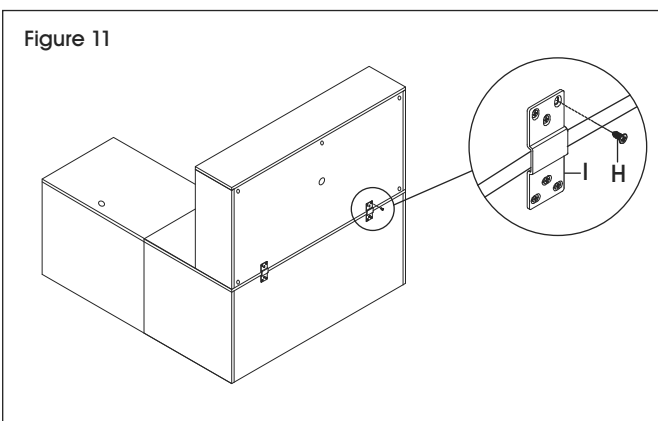

5. Move L-Desk to desired end location since assembled desk is difficult to move. Carefully place hutch onto the rear of the credenza. Attach flat brackets (I) to the hutch and credenza using #4 x 5/8" screws (H). (See Figure 11)

L-DESK HUTCH ASSEMBLY INSTRUCTIONS CONTINUED

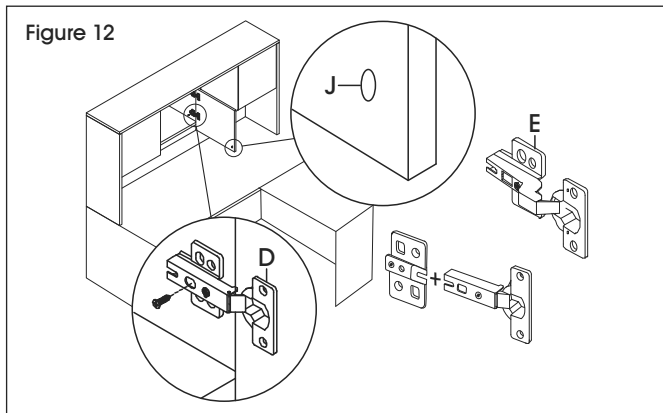

- Connect doors to hutch using center door hinges (D) and side door hinges (E). (See Figure 12)

 **NOTE:** Pre-installed hinge screws may need to be tightened or loosened to align cabinet doors.

- Apply bumper plastic (J) to inside of doors to reduce noise when closing. (See Figure 12)

PEDESTAL ASSEMBLY PARTS LIST

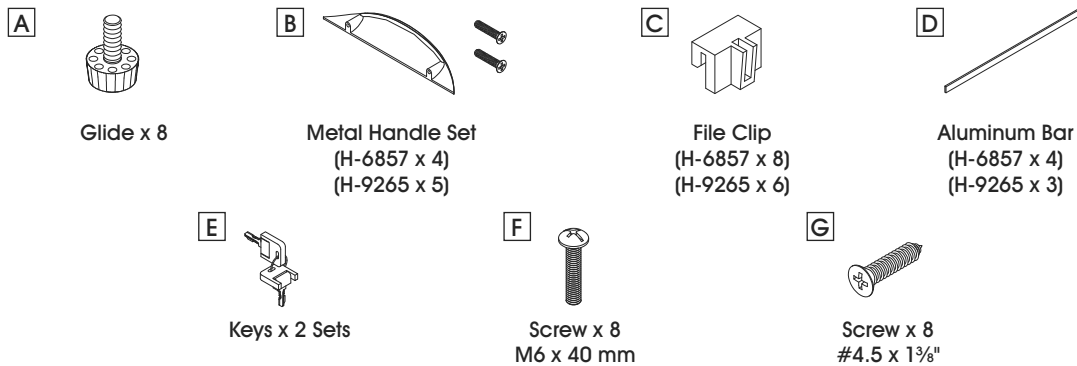

PEDESTAL ASSEMBLY INSTRUCTIONS

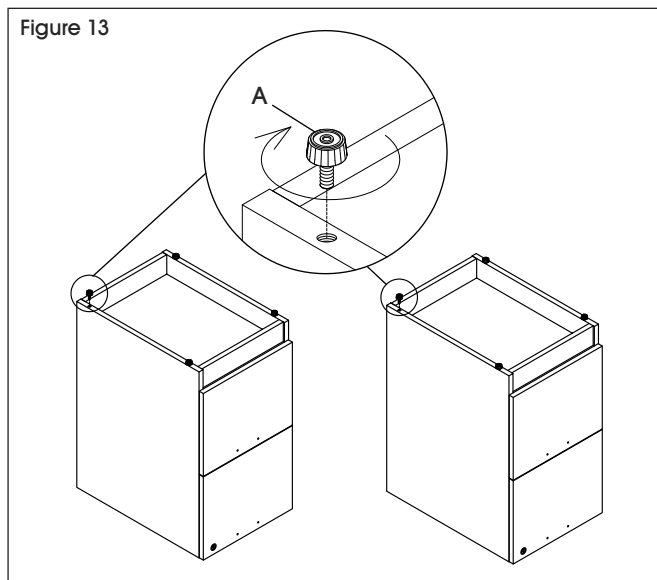

 **NOTE:** H-6857 includes two file/file pedestals. H-9265 includes one file/file pedestal and one box/box/file pedestal.

- Insert glides (A) into bottom of pedestals. (See Figure 13)

PEDESTAL ASSEMBLY INSTRUCTIONS CONTINUED

Figure 14

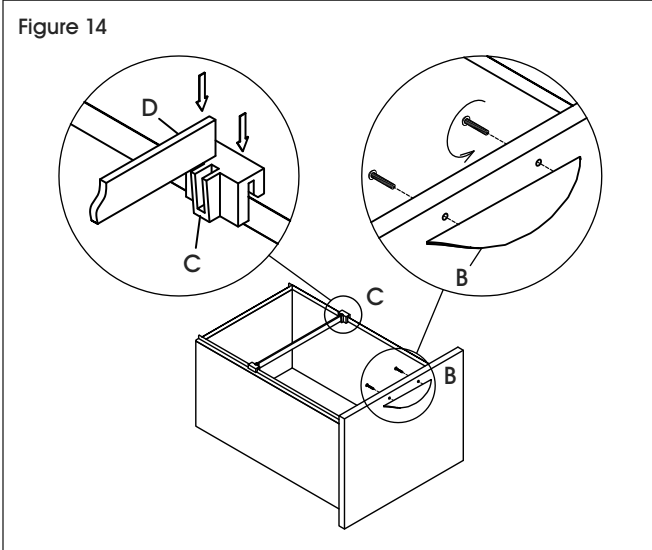

2. Remove pre-attached metal handle (B) from inside of cabinet drawer, move to the outside of drawer and re-attach using same screws and Phillips head screwdriver. (See Figure 14)
3. Attach file clips (C) to sides of drawers and insert aluminum bar (D). (See Figure 14)

Figure 15

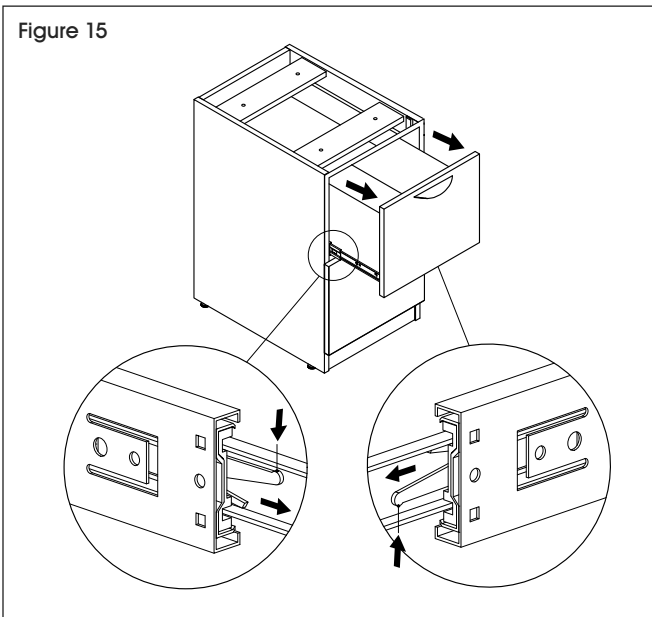

4. To remove drawer, pull up on one tab and push down on the opposite tab, then pull cabinet body out. (See Figure 15)

PEDESTAL ASSEMBLY INSTRUCTIONS CONTINUED

Figure 16

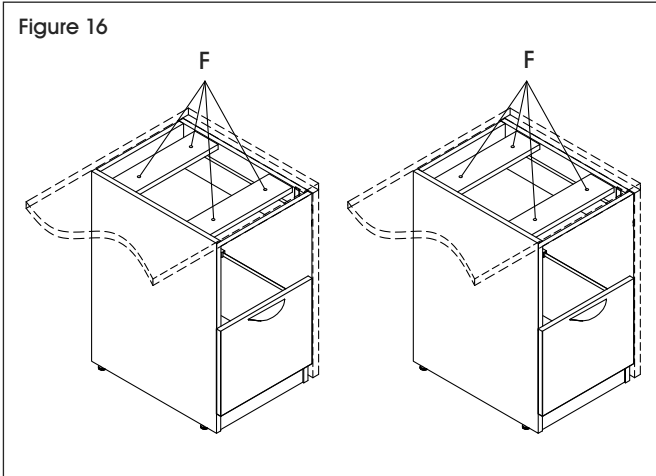

5. Align pedestals to pre-drilled holes located on underside of desk top. To attach pedestal to desk top, insert M6 x 40 mm screw (F) from underside of pedestal. For extra stability, use #4.5 x 1 $\frac{3}{8}$ " screws (G) to attach pedestal to desk side panel. (See Figure 16)
6. Replace top drawer in each pedestal.

Completed Assembly

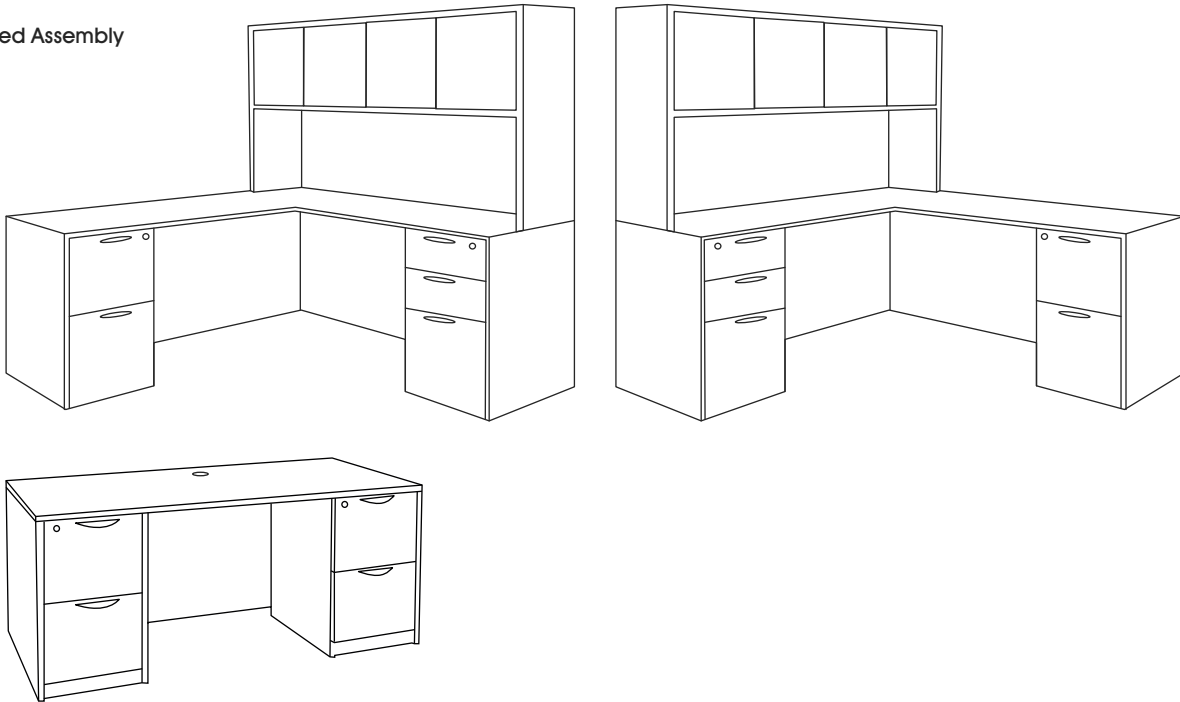

ULINE

1-800-295-5510
uline.com

ULINE

CREDENZA PARA OFICINA O ESCRITORIO EN L CON LIBRERO

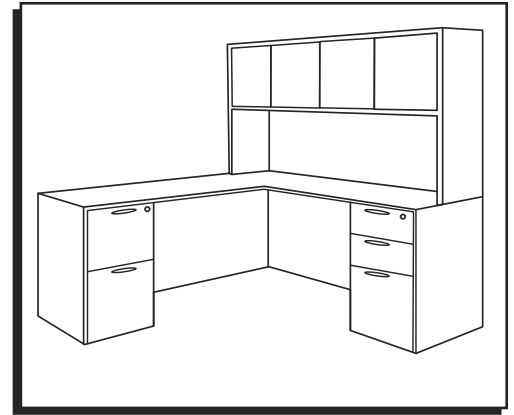
800-295-5510
uline.mx

HERRAMIENTAS NECESARIAS

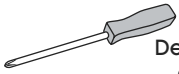

Desarmador de Cruz

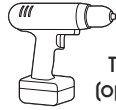

Taladro (opcional)



Se recomienda Armar Entre Dos Personas



ALTO: Si está armando el Escritorio en U con Librero, vea las instrucciones incluidas en la Estructura del Escritorio H-6855 de 72 x 36".

LISTA DE PARTES PARA EL ENSAMBLE DE LA ESTRUCTURA DEL ESCRITORIO/CREDENZA

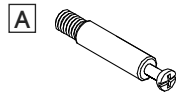

14 Pasadores de Tuerca Minifix



14 Tuercas Minifix

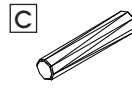

11 Taquetes



4 Niveladores

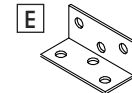

5 Soportes en L

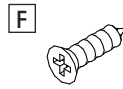

35 Tornillos #4 x 5/8"



2 Tapas de Ojal

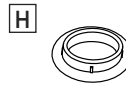

5 Tapas Profundas para Tuercas Minifix

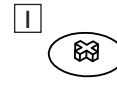

9 Tapas para Tuerca Minifix

INSTRUCCIONES DEL ENSAMBLE DE LA ESTRUCTURA DEL ESCRITORIO/CREDENZA



Diagrama 1



NOTA: La estructura de la credenza será utilizada como escritorio principal del Escritorio en L con Librero.

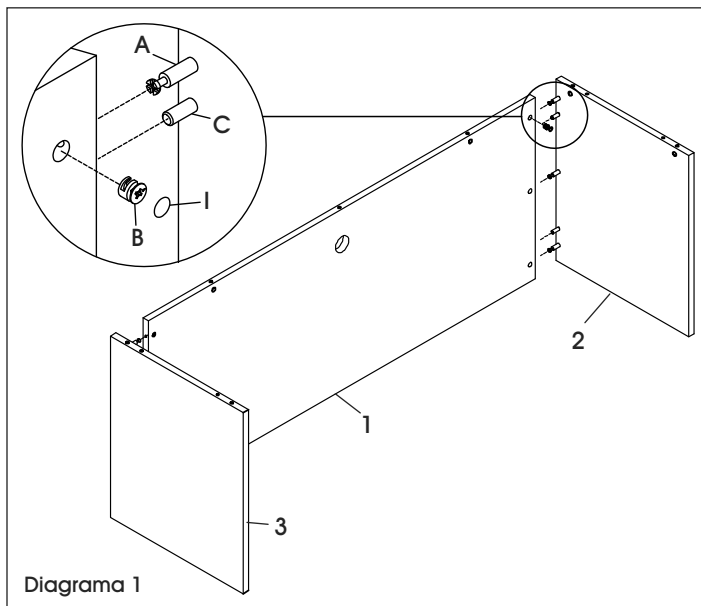

NOTA: Ensamble la unidad sobre una superficie lisa que no deje marcas para evitar rayones. Verifique que cuente con todas las partes listadas.

1. Inserte las tuercas minifix (B) en el panel posterior (1). Inserte los pasadores de las tuercas minifix (A) y los taquetes (C) en los paneles laterales (2 y 3). Fije los paneles y apriete las tuercas minifix utilizando un desarmador de cruz. (Vea Diagrama 1)



IMPORTANTE: Haga 1/4 de giro a la derecha para bloquear. Asegúrese de que la flecha apunte hacia el borde del panel antes de insertarla en el orificio del panel.

IMPORTANTE: Función de la Leva

1/4 de Giro a la Derecha para Bloquear



NOTA: Puede colocar las tapas de las tuercas minifix una vez que las haya apretado para darle una apariencia terminada.

INSTRUCCIONES DEL ENSAMBLE DE LA ESTRUCTURA DEL ESCRITORIO/CREDENZA

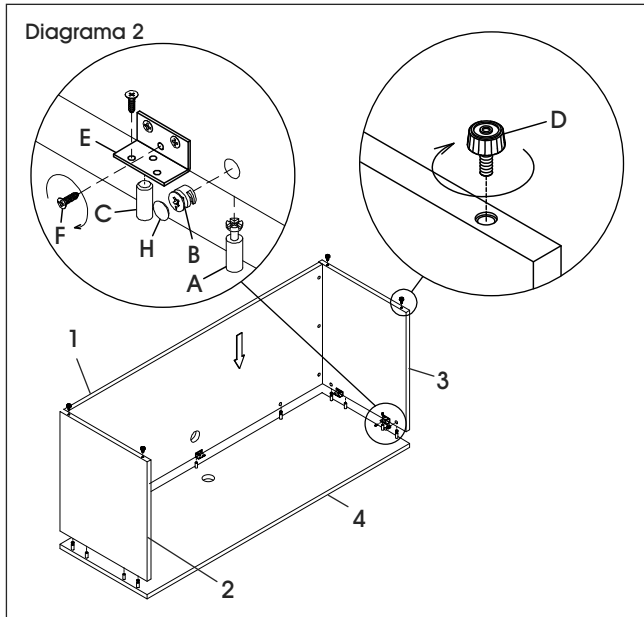

2. Inserte las tuercas minifix (B) en los paneles laterales (2 y 3). Inserte los pasadores de las tuercas minifix (A) y los taquetes (C) en el panel superior (4). Fije los paneles y apriete las tuercas minifix utilizando un desarmador de cruz. (Vea Diagrama 2)
3. Utilice los Soportes en L (E) para conectar el panel posterior (1) y el panel superior (4). Fíjelos utilizando tornillos #4 x 5/8" (F). Para estabilidad adicional, puede instalar los Soportes en L para conectar los paneles laterales (2 y 3) al panel superior (4), pero hágalo solo si no va a instalar los pedestales. (Vea Diagrama 2)
4. Inserte los niveladores (D) en los paneles laterales (2 y 3). (Vea Diagrama 2)

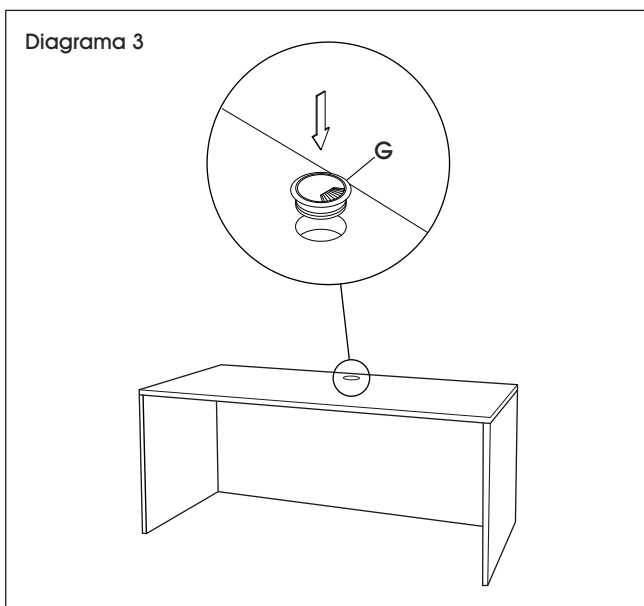

5. Inserte las tapas de los ojales (G) en los paneles superior y posterior. (Vea Diagrama 3)

ALTO Para el ensamble de la Credenza para Oficina, proceda al Ensamble del Pedestal en la página 14. Para el ensamble del Escritorio en L, proceda al Ensamble del Retorno del Escritorio en L en la página 11.

LISTA DE PARTES DEL ENSAMBLE DEL RETORNO PARA ESCRITORIO EN L



INSTRUCCIONES DEL ENSAMBLE DEL RETORNO PARA ESCRITORIO EN L

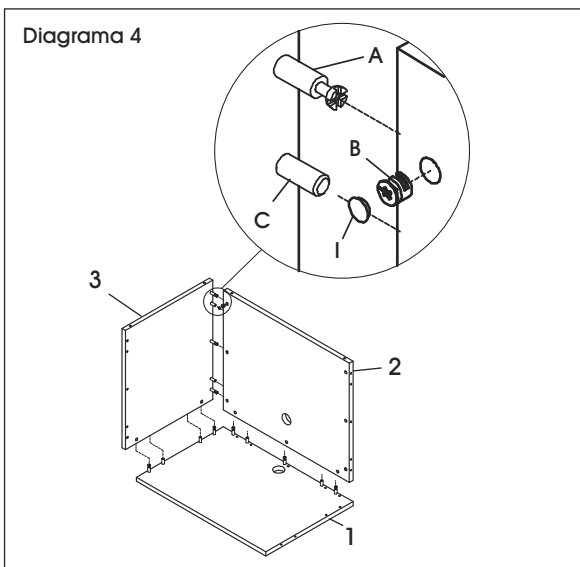

1. Inserte las tuercas minifix (B) en el panel posterior (2) y el panel lateral (3). Inserte los pasadores de las tuercas minifix (A) y los taquetes (C) en el panel superior (1) y panel lateral (3). Fije los paneles y apriete las tuercas minifix utilizando un desarmador de cruz. (Vea Diagrama 4)



NOTA: El diagrama muestra la configuración del lado derecho del Escritorio en L. Para la configuración del lado izquierdo del Escritorio en L, voltee el panel lateral al lado opuesto.

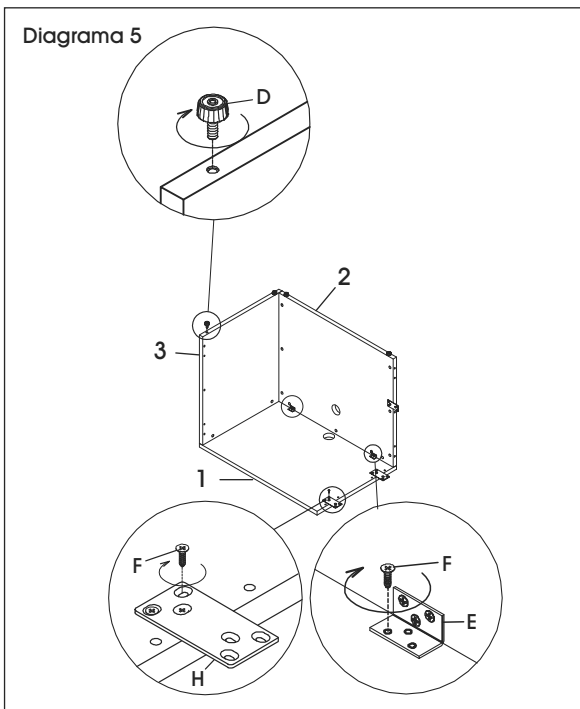

2. Inserte los niveladores (D) en el panel posterior (2) y panel lateral (3). (Vea Diagrama 5)
3. Utilice los Soportes en L (E) para conectar el panel superior (1) y el panel posterior (2). Fije utilizando tornillos #4 x 5/8" (F). (Vea Diagrama 5)



NOTA: Si está instalando un pedestal, no se requieren los Soportes en L para conectar el panel superior y lateral.

4. Fije un extremo de los soportes planos (H) al panel superior (1) y al panel posterior (2) utilizando tornillos #4 x 5/8" (F). (Vea Diagrama 5)

CONTINUACIÓN DE INSTRUCCIONES DEL ENSAMBLE DEL RETORNO PARA ESCRITORIO EN L

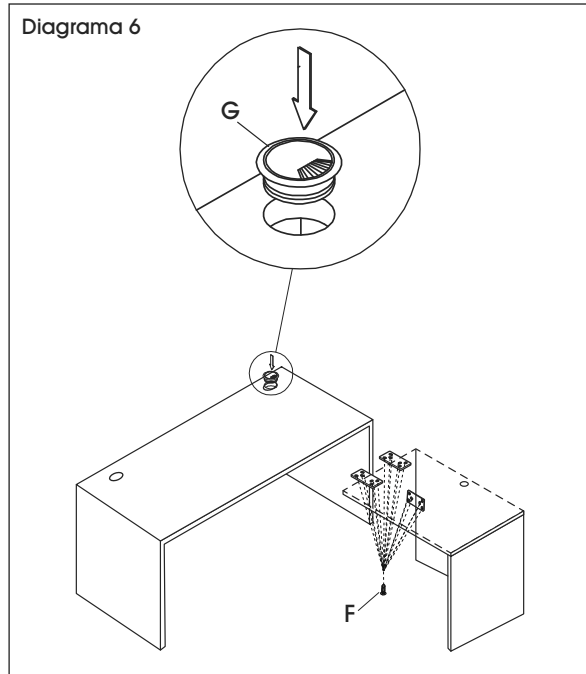

5. Voltee el retorno con cuidado y fije el otro extremo de los soportes planos debajo de la estructura del escritorio/credenza utilizando tornillos #4 x 5/8" (F). (Vea Diagrama 6)
6. Inserte las tapas de los ojales (G) en los paneles superior y posterior. (Vea Diagrama 6)

LISTA DE PARTES DEL ENSAMBLE DEL ESCRITORIO EN L CON LIBRERO

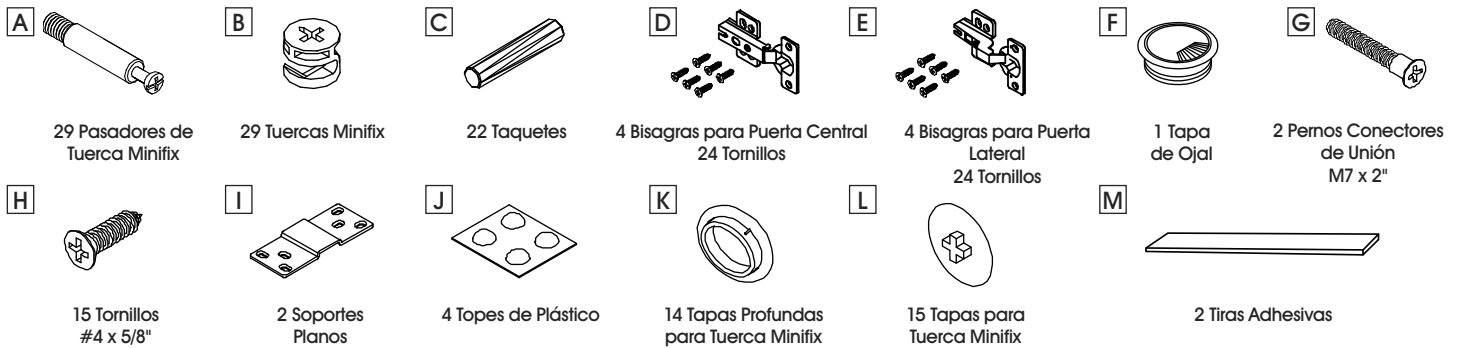

INSTRUCCIONES DEL ENSAMBLE DEL ESCRITORIO EN L CON LIBRERO

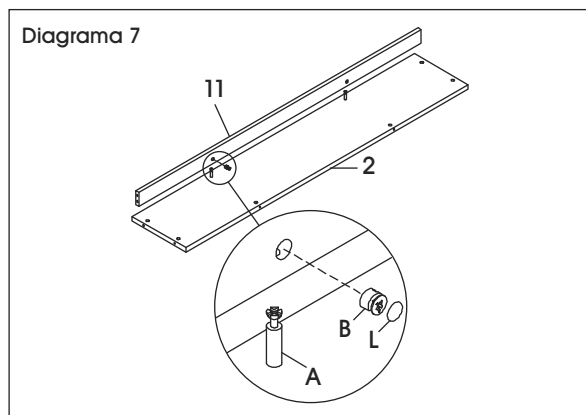

1. Inserte las tuercas minifix (B) en el panel de borde (11). Inserte los pasadores de tuerca minifix (A) en el panel repisa (2). Fije los paneles y apriete las tuercas minifix utilizando un desarmador de cruz. (Vea Diagrama 7)

CONTINUACIÓN DE LAS INSTRUCCIONES DEL ENSAMBLE DEL ESCRITORIO EN L CON LIBRERO

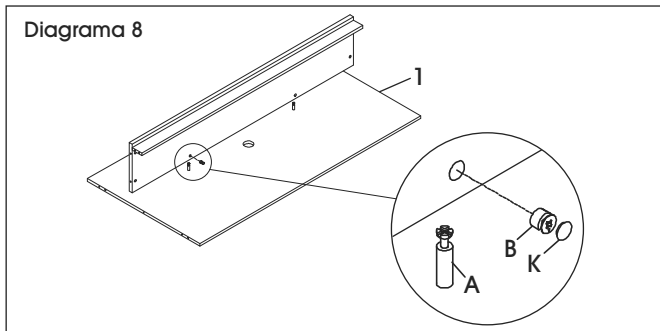

2. Inserte las tuercas minifix (B) en el panel repisa. Inserte los pasadores de las tuercas minifix (A) en el panel posterior (1). Fije los paneles y apriete las tuercas minifix utilizando un desarmador de cruz. (Vea Diagrama 8)

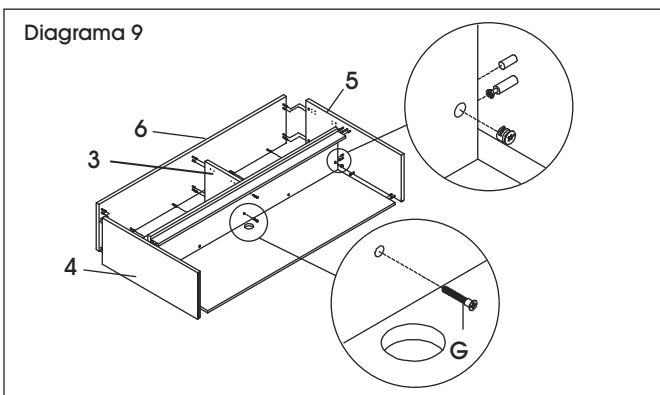

3. Inserte las tuercas minifix (B), los pasadores de tuercas minifix (A) y los taquetes (C) en los paneles restantes. Fije todos los paneles y apriete las tuercas minifix utilizando un desarmador de cruz. (Vea Diagrama 9)

 **NOTA:** No apriete el perno conector de unión (G) hasta que instale el panel superior.

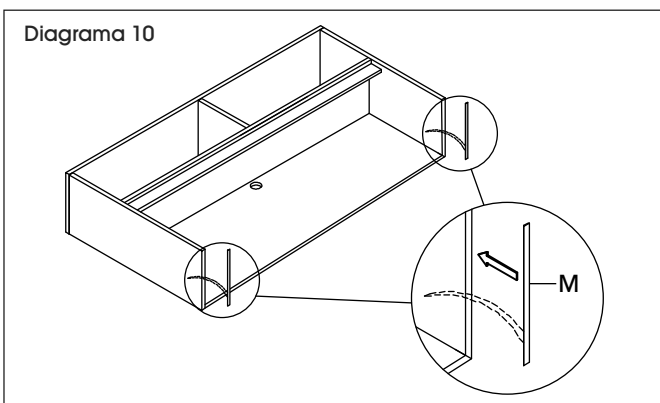

4. Pegue las tiras adhesivas (M) en la parte inferior del librero. (Vea Diagrama 10)

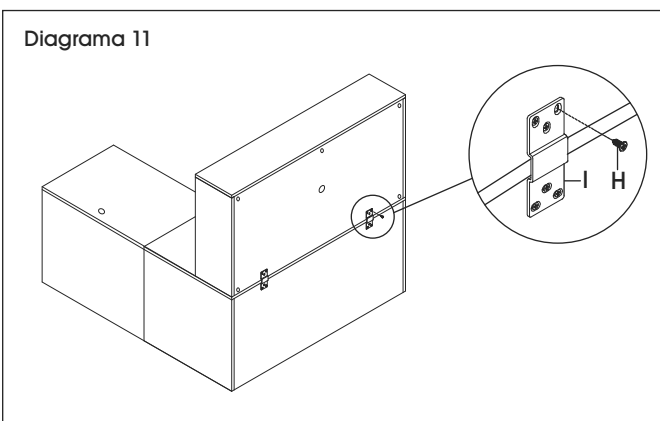

5. Mueva el Escritorio en L a la ubicación deseada, puesto que el escritorio ensamblado es difícil de mover. Coloque con cuidado el librero en la parte posterior de la credenza. Fije los soportes planos (I) al librero o credenza utilizando tornillos #4 x 5/8" (H). (Vea Diagrama 11)

CONTINUACIÓN DE LAS INSTRUCCIONES DEL ENSAMBLE DEL ESCRITORIO EN L CON LIBRERO

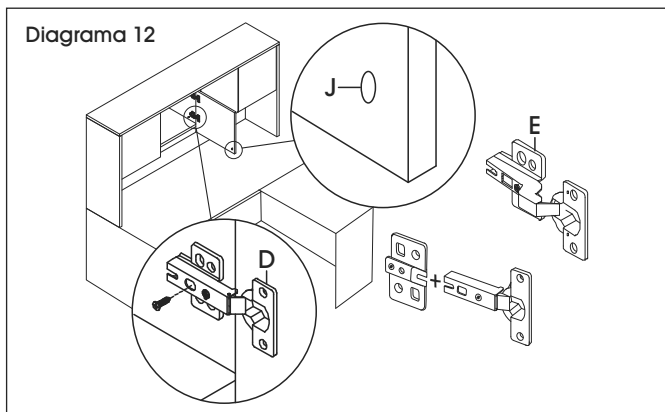

6. Conecte las puertas del librero utilizando las bisagras de las puertas centrales (D) y las bisagras de las puertas laterales (E). (Vea Diagrama 12)

 **NOTA:** Para alinear las puertas de los gabinetes necesitará apretar o aflojar los tornillos preinstalados de las bisagras.

7. Para aminorar el ruido al cerrar, pegue un tope de plástico (J) en el interior de las puertas. (Vea Diagrama 12)

LISTA DE PARTES DEL ENSAMBLE DEL PEDESTAL



8 Niveladores

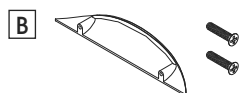

Set de Asas de Metal
(4 del H-6857)
(5 del H-9265)



Clips para Carpetas
(8 del H-6857)
(6 del H-9265)

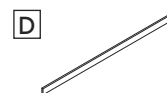

Barras de Aluminio
(4 del H-6857)
(3 del H-9265)

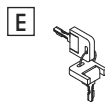

2 Sets de Llaves



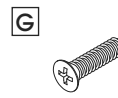

8 Tornillos
M6 x 40 mm

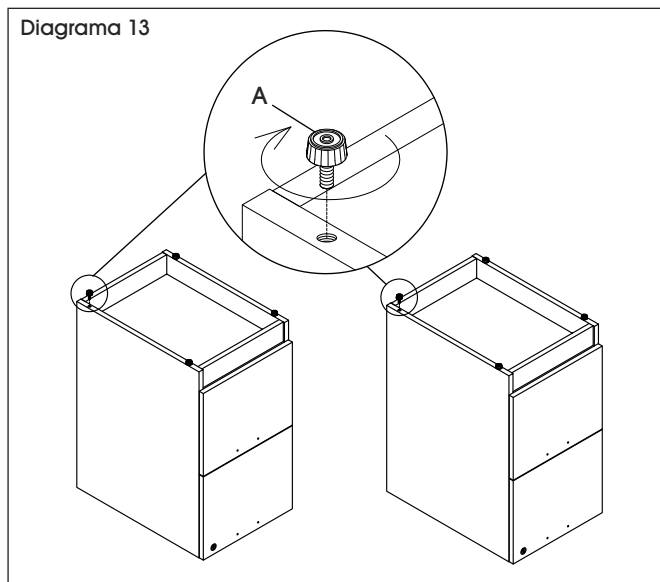

8 Tornillos
#4.5 x 1 3/8"

INSTRUCCIONES DEL ENSAMBLE DEL PEDESTAL



 **NOTA:** El H-6857 incluye dos archiveros de pedestal con dos cajones para archivar. El H-9265 incluye un archivero de pedestal con dos cajones para archivar y un archivero pedestal con dos cajones y un cajón para archivar.

1. Inserte los niveladores (A) en la parte inferior de los pedestales. (Vea Diagrama 13)

CONTINUACIÓN DE INSTRUCCIONES DEL ENSAMBLE DEL PEDESTAL

Diagrama 14

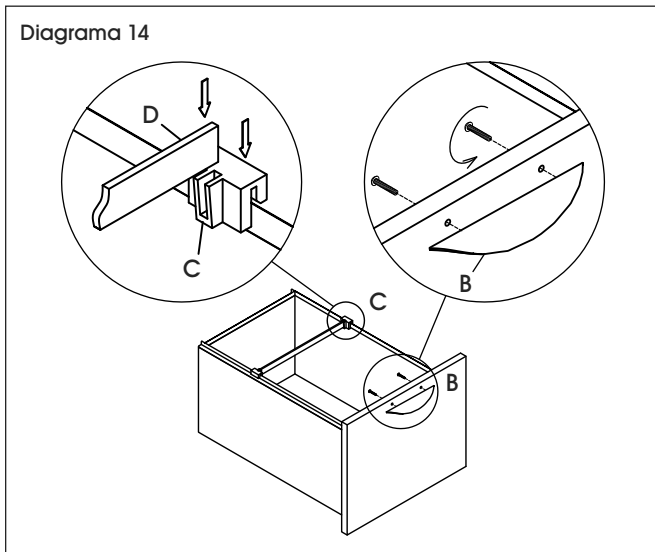

2. Retire el asa de metal (B) instalada adentro del cajón del gabinete y llévela hacia afuera del cajón para fijarla utilizando los mismos tornillos y un desarmador de cruz. (Diagrama 14)
3. Fije los clips para carpetas (C) a los laterales de los cajones e inserte la barra de aluminio (D). (Vea Diagrama 14)

Diagrama 15

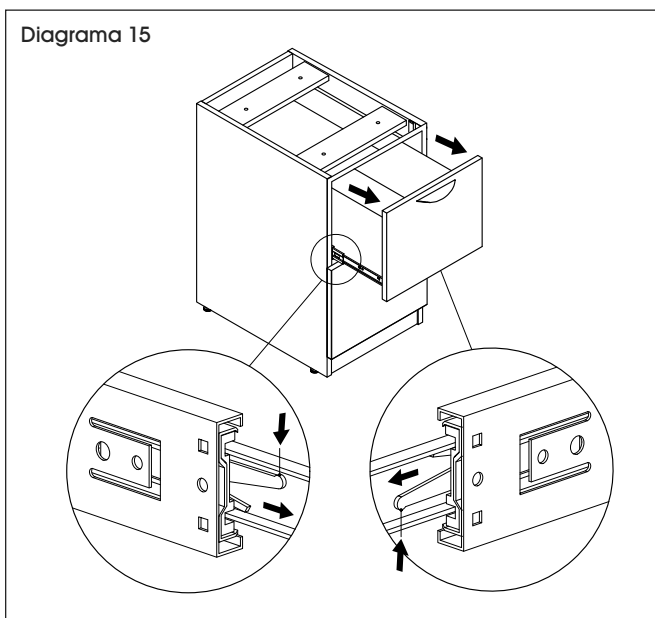

4. Para quitar el cajón, levante una pestaña y presione hacia abajo la pestaña opuesta, luego saque el cuerpo del gabinete. (Vea Diagrama 15)

CONTINUACIÓN DE INSTRUCCIONES DEL ENSAMBLE DEL PEDESTAL

Diagrama 16

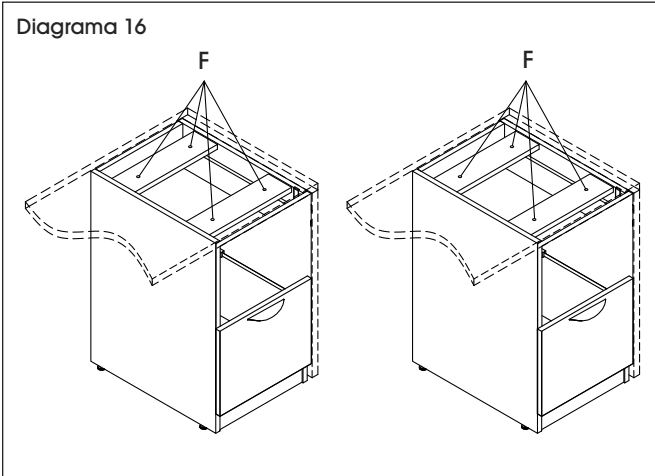

5. Alinee los pedestales con los orificios preperforados ubicados en la parte de abajo de la cubierta del escritorio. Para fijar el pedestal a la cubierta del escritorio, inserte el tornillo M6 x 40 mm (F) debajo del pedestal. Para mayor estabilidad, utilice tornillos #4.5 x 1 $\frac{3}{8}$ " (G) para fijar el pedestal al panel lateral del escritorio. (Vea Diagrama 16)
6. Coloque el cajón superior de nuevo en cada pedestal.

Ensamble Terminado

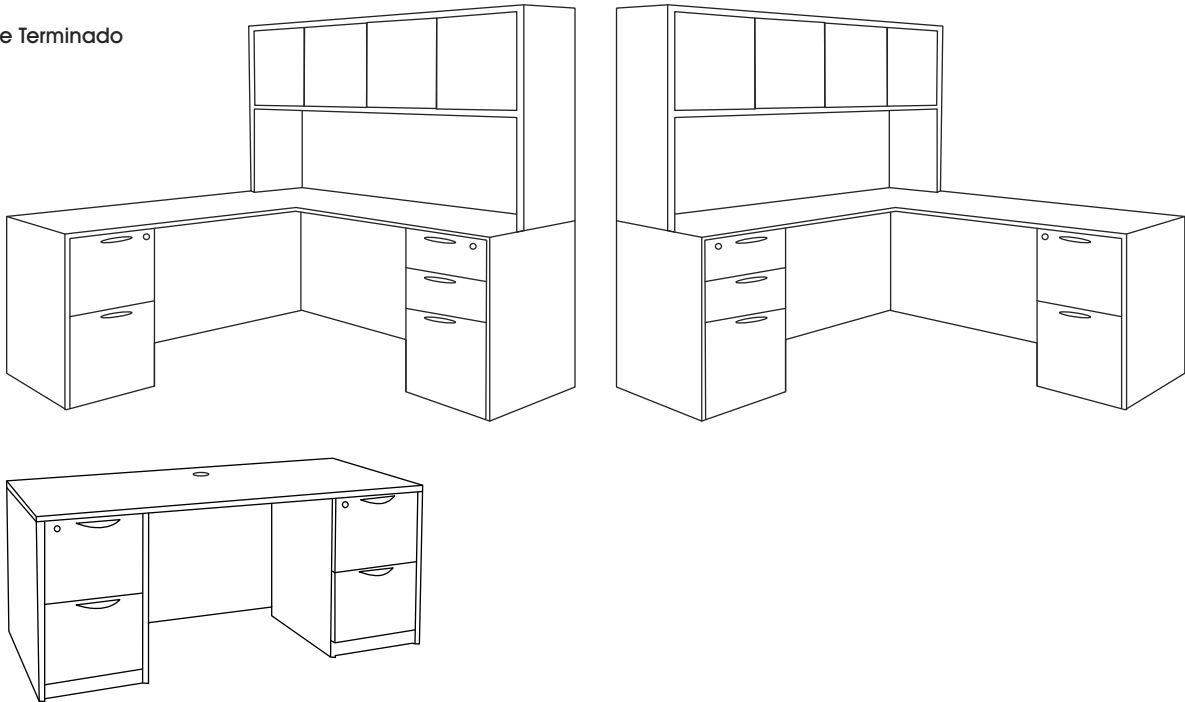

ULINE

800-295-5510
uline.mx

ULINE

BAHUT OU BUREAU EN L AVEC HUCHE

1 800 295-5510

uline.ca

OUTILS REQUIS

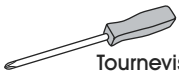

Tournevis cruciforme



Perceuse (optionnel)



Montage à deux personnes recommandé

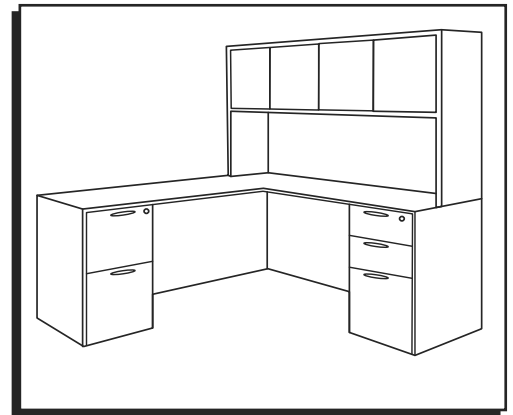

ARRÊT : Si vous montez un bureau en U avec huche, reportez-vous aux instructions qui sont incluses avec le bureau H-6855 de 72 x 36 po.

LISTE DES PIÈCES POUR LE MONTAGE DU BUREAU/BAHUT

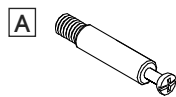

Goujon d'excentrique x 14



Excentrique x 14

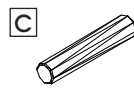

Cheville x 11



Patin x 4

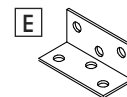

Support en L x 5

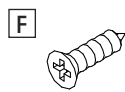
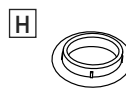
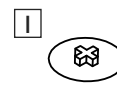
Vis x 35
N° 4 x 5/8 poCapuchon pour
passe-fil x 2Cache profond pour
excentrique x 5Cache pour
excentrique x 9

INSTRUCTIONS DE MONTAGE DU BUREAU/BAHUT

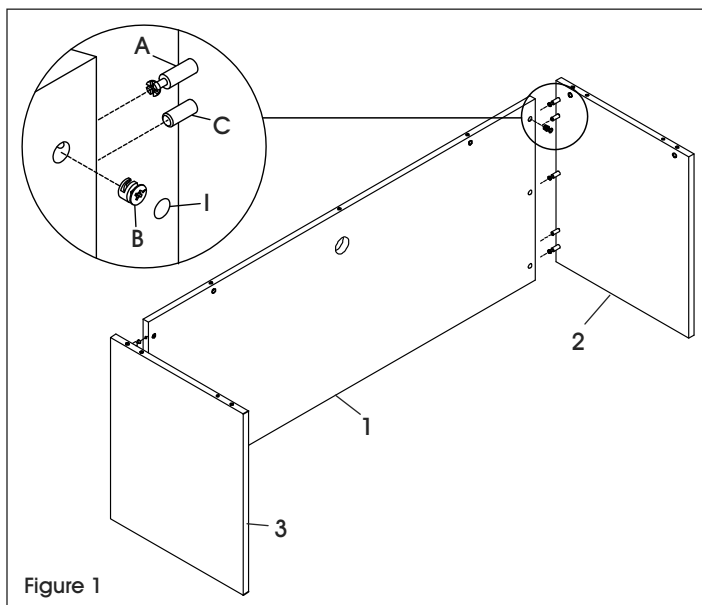

Figure 1



REMARQUE : Le bahut servira de bureau principal pour le bureau en L avec huche.



REMARQUE : Montez le bahut sur une surface lisse qui ne marque pas afin d'éviter les rayures. Vérifiez que toutes les pièces énumérées sont présentes.

1. Insérez les excentriques (B) dans le panneau arrière (1). Insérez les goujons d'excentrique (A) et les chevilles (C) dans les panneaux latéraux (2 et 3). Fixez les panneaux et serrez les excentriques avec un tournevis cruciforme. (Voir Figure 1)



IMPORTANT : Tournez l'excentrique de 1/4 de tour vers la droite pour le verrouiller. Vérifiez que la flèche pointe vers le bord du panneau avant de l'insérer dans le trou du panneau.

IMPORTANT : Fonctionnement de l'excentrique



1/4 de tour vers la droite
pour verrouiller



REMARQUE : Une fois que les excentriques ont été serrés, les caches pour excentrique peuvent être installés pour donner un aspect fini.

INSTRUCTIONS DE MONTAGE DU BUREAU/BAHUT

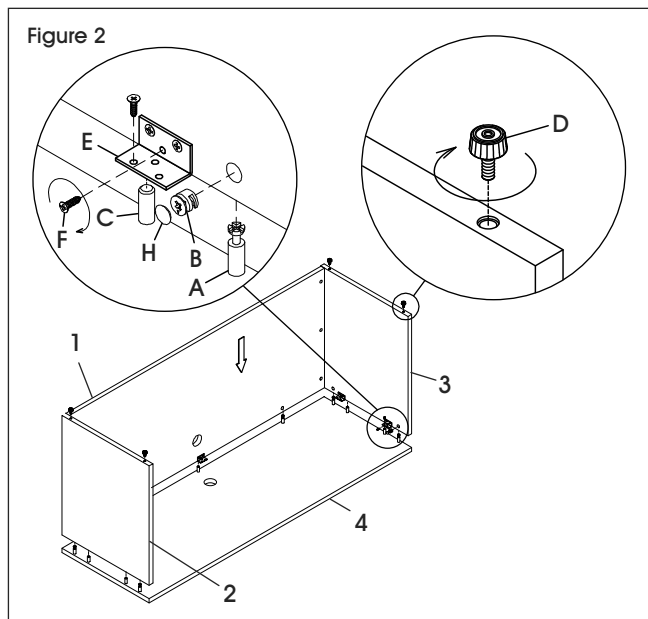

2. Insérez les excentriques (B) dans les panneaux latéraux (2 et 3). Insérez les goujons d'excentrique (A) et les chevilles (C) dans le panneau supérieur (4). Fixez les panneaux et serrez les excentriques avec un tournevis cruciforme. (Voir Figure 2)
3. Utilisez les supports en L (E) pour relier le panneau arrière (1) et le panneau supérieur (4). Fixez-les avec des vis n° 4 x 5/8 po (F). Les supports en L peuvent être installés pour relier les panneaux latéraux (2 et 3) au panneau supérieur (4) pour une meilleure stabilité, mais seulement si les caissons ne sont pas montés. (Voir Figure 2)
4. Insérez les patins (D) dans les panneaux latéraux (2 et 3). (Voir Figure 2)

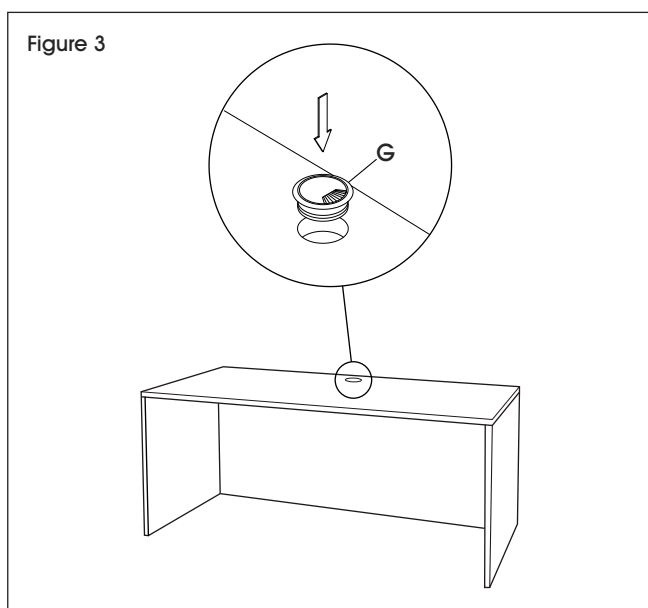

5. Insérez des capuchons pour passe-fil (G) dans les panneaux supérieur et arrière. (Voir Figure 3)



ARRÊT : Pour le montage du bahut, passez au montage du caisson à la page 20. Pour le montage du bureau en L avec huche, passez au montage du retour de bureau en L à la page 17.

LISTE DES PIÈCES POUR LE MONTAGE DU RETOUR DE BUREAU EN L

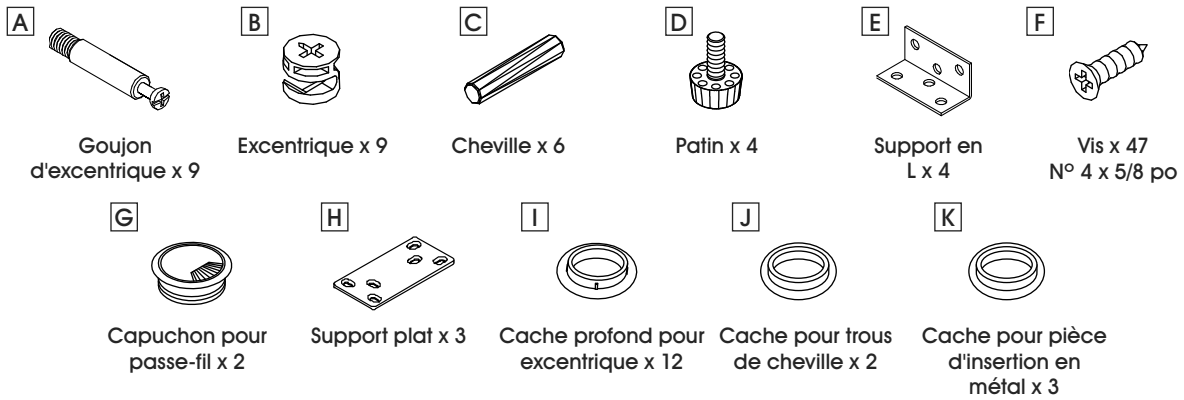

INSTRUCTIONS DE MONTAGE DU RETOUR DE BUREAU EN L

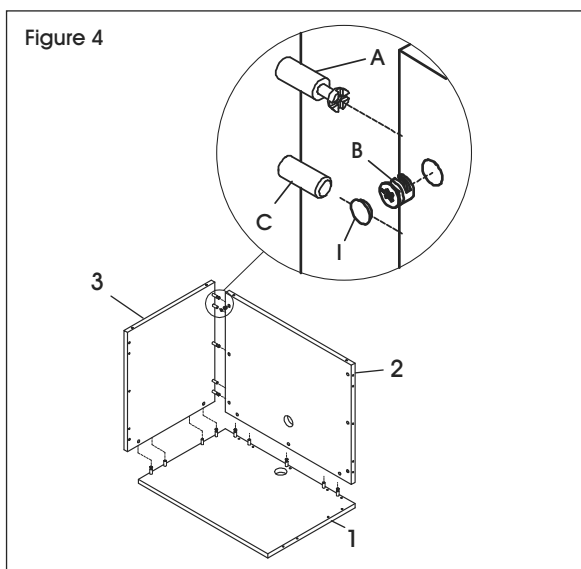

1. Insérez les excentriques (B) dans le panneau arrière (2) et latéral (3). Insérez les goujons d'excentrique (A) et les chevilles (C) dans le panneau supérieur (1) et latéral (3). Fixez les panneaux et serrez les excentriques avec un tournevis cruciforme. (Voir Figure 4)



REMARQUE : Le schéma illustre la configuration en L du côté droit. Pour la configuration en L du côté gauche, tournez le panneau latéral du côté opposé.

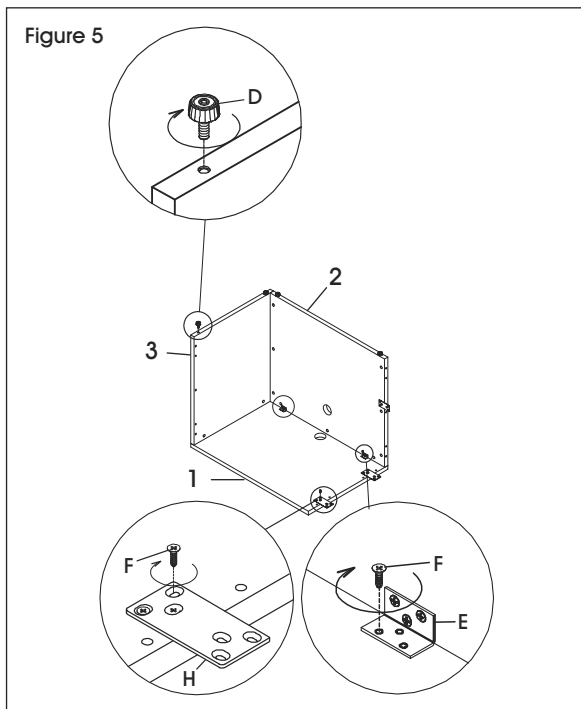

2. Insérez les patins (D) dans le panneau arrière (2) et latéral (3). (Voir Figure 5)
3. Utilisez les supports en L (E) pour relier le panneau supérieur (1) et le panneau arrière (2). Fixez-les avec des vis n° 4 x 5/8 po (F). (Voir Figure 5)



REMARQUE : Si vous montez un caisson, les supports en L ne sont pas nécessaires pour relier le panneau supérieur et latéral.

4. Fixez une des extrémités des supports plats (H) au panneau supérieur (1) et au panneau arrière (2) avec des vis n° 4 x 5/8 po (F). (Voir Figure 5)

INSTRUCTIONS DE MONTAGE DU RETOUR DE BUREAU EN L SUITE

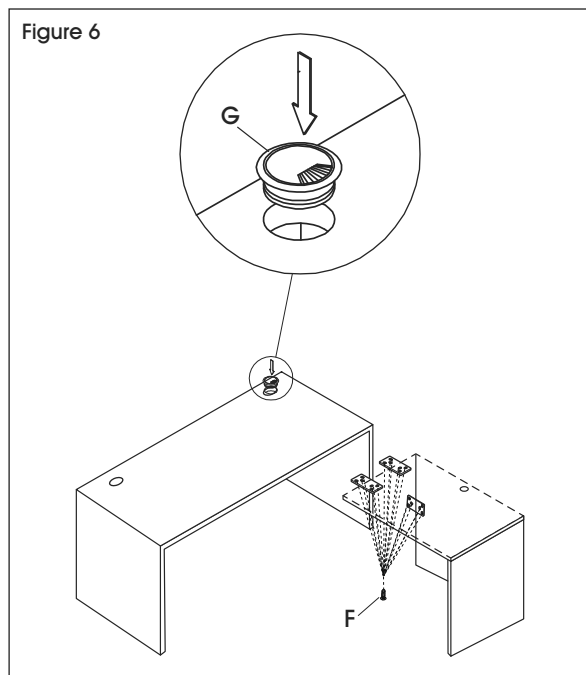

5. Tournez avec soin le retour et fixez l'autre extrémité des supports plats à la face inférieure du bureau/bahut avec des vis n° 4 x 5/8 po (F). (Voir Figure 6)
6. Insérez des capuchons pour passe-fil (G) dans les panneaux supérieur et arrière. (Voir Figure 6)

LISTE DES PIÈCES POUR LE MONTAGE DE LA HUCHE DE BUREAU EN L

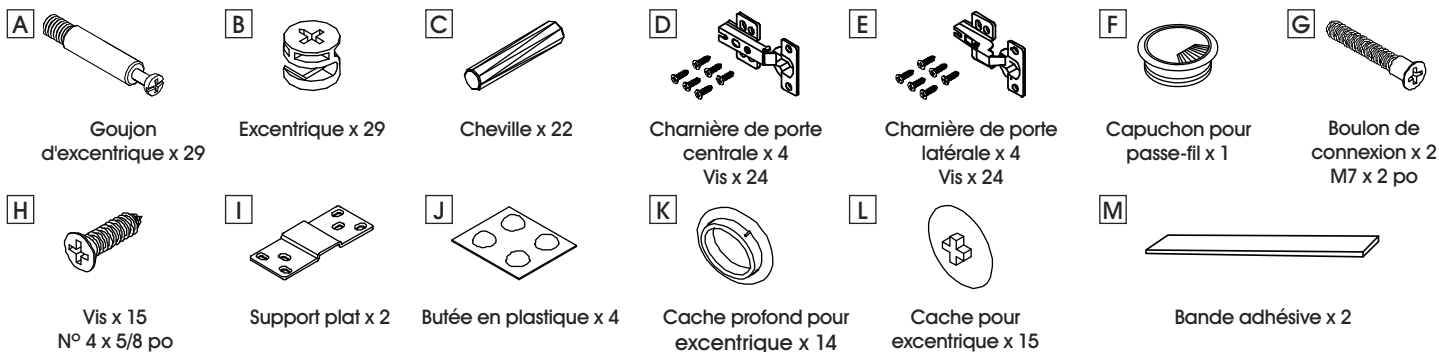

INSTRUCTIONS DE MONTAGE DE LA HUCHE DE BUREAU EN L

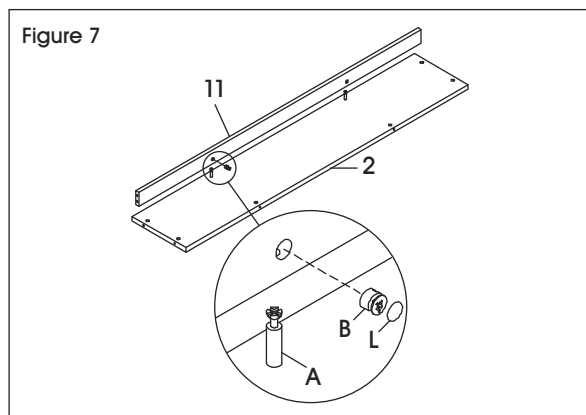

1. Insérez les excentriques (B) dans le panneau de rebord (11). Insérez les goujons d'excentrique (A) dans le panneau de tablette (2). Fixez les panneaux et serrez les excentriques avec un tournevis cruciforme. (Voir Figure 7)

INSTRUCTIONS DE MONTAGE DE LA HUCHE DE BUREAU EN L SUITE

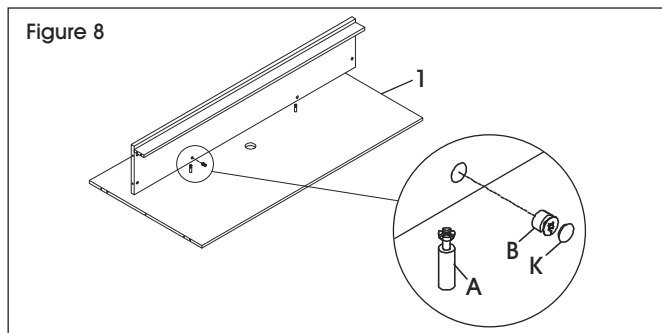

2. Insérez les excentriques (B) dans le panneau de tablette. Insérez les goujons d'excentrique (A) dans le panneau arrière (1). Fixez les panneaux et serrez les excentriques avec un tournevis cruciforme. (Voir Figure 8)

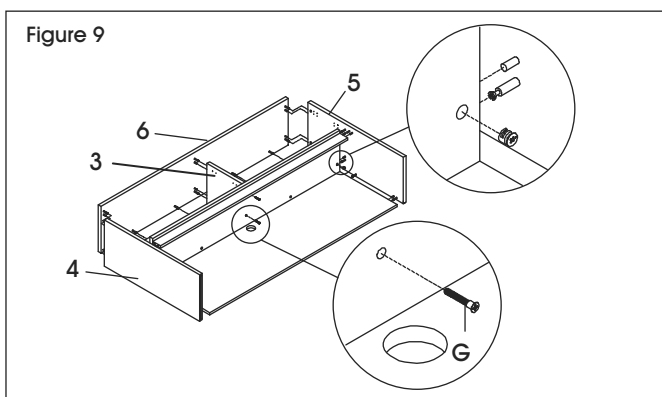

3. Insérez les excentriques (B), les goujons d'excentrique (A) et les chevilles (C) dans les panneaux restants. Fixez tous les panneaux et serrez les excentriques avec un tournevis cruciforme. (Voir Figure 9)

 **REMARQUE :** Ne serrez pas le boulon de connexion (G) avant que le panneau supérieur ne soit installé.

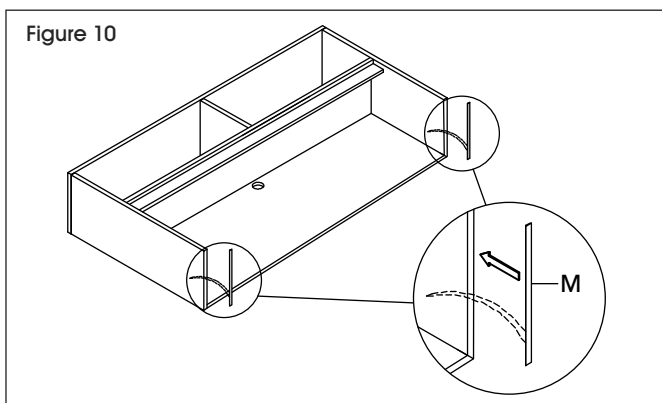

4. Appliquez les bandes adhésives (M) au bas de la huche. (Voir Figure 10)

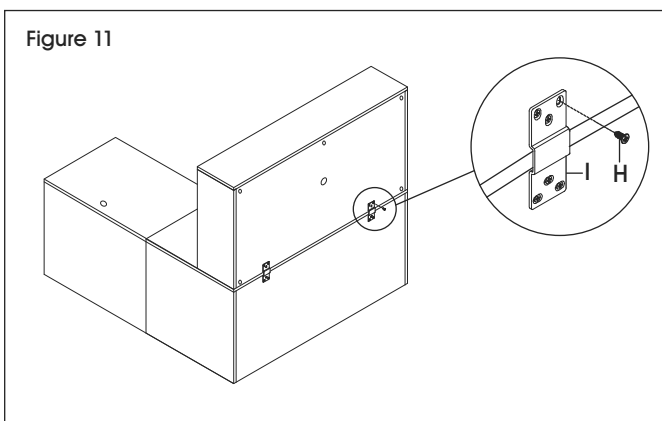

5. Placez le bureau en L à l'emplacement final, car il est difficile à déplacer une fois le montage entièrement effectué. Placez avec soin la huche sur la partie arrière du bahut. Fixez des supports plats (I) à la huche et au bahut avec des vis n° 4 x 5/8 po (H). (Voir Figure 11)

INSTRUCTIONS DE MONTAGE DE LA HUCHE DE BUREAU EN L SUITE

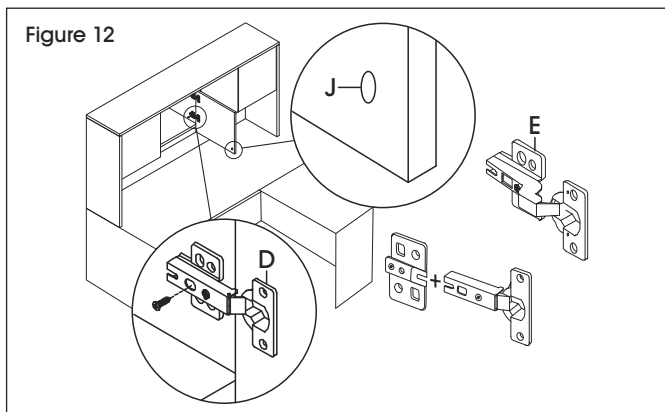

- Fixez les portes à la huche avec les charnières de portes centrales (D) et latérales (E). (Voir Figure 12)

REMARQUE : Il peut être nécessaire de serrer ou desserrer les vis des charnières préinstallées pour aligner les portes de la huche.

- Appliquez les butées en plastique (J) à l'intérieur des portes pour amortir le bruit lors de la fermeture. (Voir Figure 12)

LISTE DES PIÈCES POUR LE MONTAGE DU CAISSON

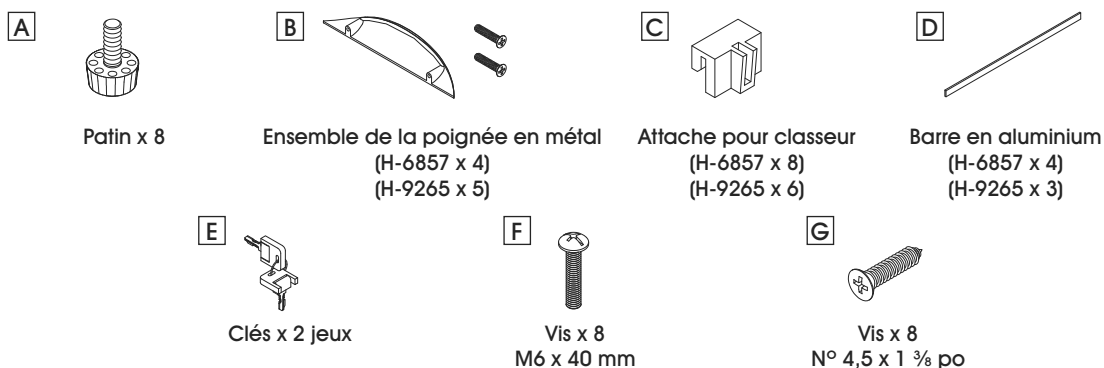

INSTRUCTIONS DE MONTAGE DU CAISSON

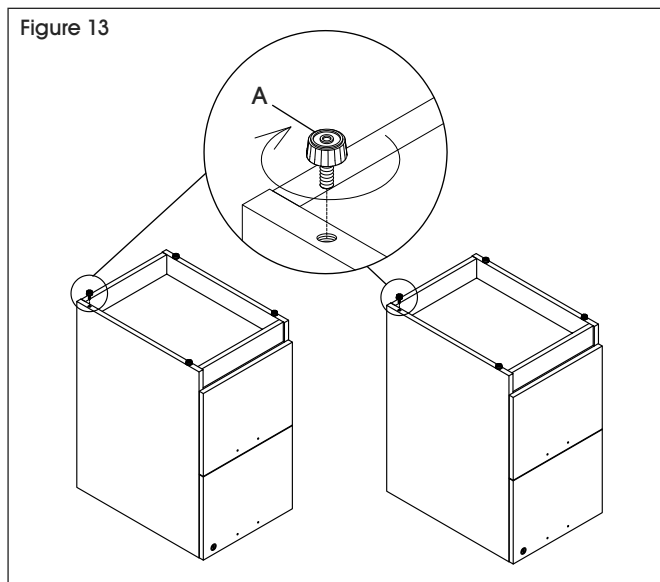

REMARQUE : Le modèle H-6857 comprend deux caissons classeur/classeur. Le modèle H-9265 comprend un caisson classeur/classeur et un caisson tiroir/tiroir/classeur.

- Insérez les patins (A) dans le bas des caissons. (Voir Figure 13)

INSTRUCTIONS DE MONTAGE DU CAISSON SUITE

Figure 14

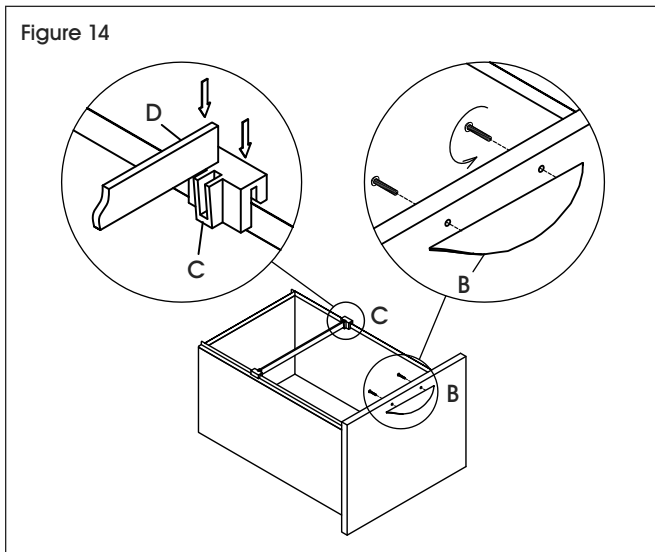

2. Retirez la poignée en métal (B) préinstallée à l'intérieur du tiroir, déplacez-la à l'extérieur et fixez-la à nouveau en utilisant les mêmes vis et le tournevis cruciforme. (Voir Figure 14)
3. Fixez les attaches pour classeur (C) sur les côtés des tiroirs et insérez la barre en aluminium (D). (Voir Figure 14)

Figure 15

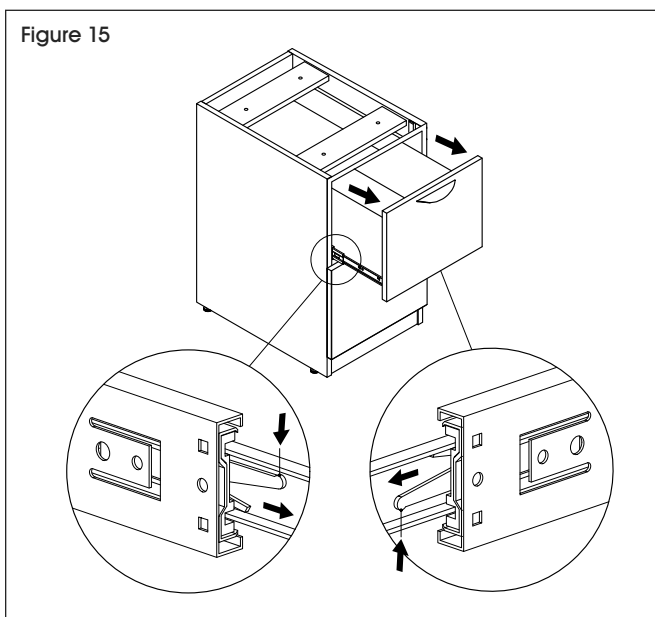

4. Pour retirer le tiroir, tirez vers le haut sur une languette et poussez vers le bas sur la languette opposée, puis retirez le corps du tiroir. (Voir Figure 15)

INSTRUCTIONS DE MONTAGE DU CAISSON SUITE

Figure 16

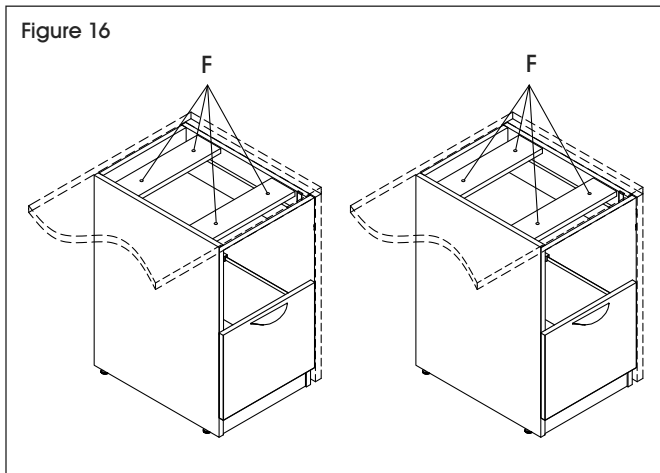

5. Alignez les caissons sur les trous prépercés sous la surface de bureau. Pour fixer le caisson à la surface, insérez des vis M6 x 40 mm (F) sur la face inférieure du caisson. Fixez le caisson au panneau latéral du bureau pour plus de stabilité avec des vis n° 4,5 x 1 3/8 po (G). (Voir Figure 16)
6. Réinsérez le tiroir supérieur de chaque caisson.

Montage complété

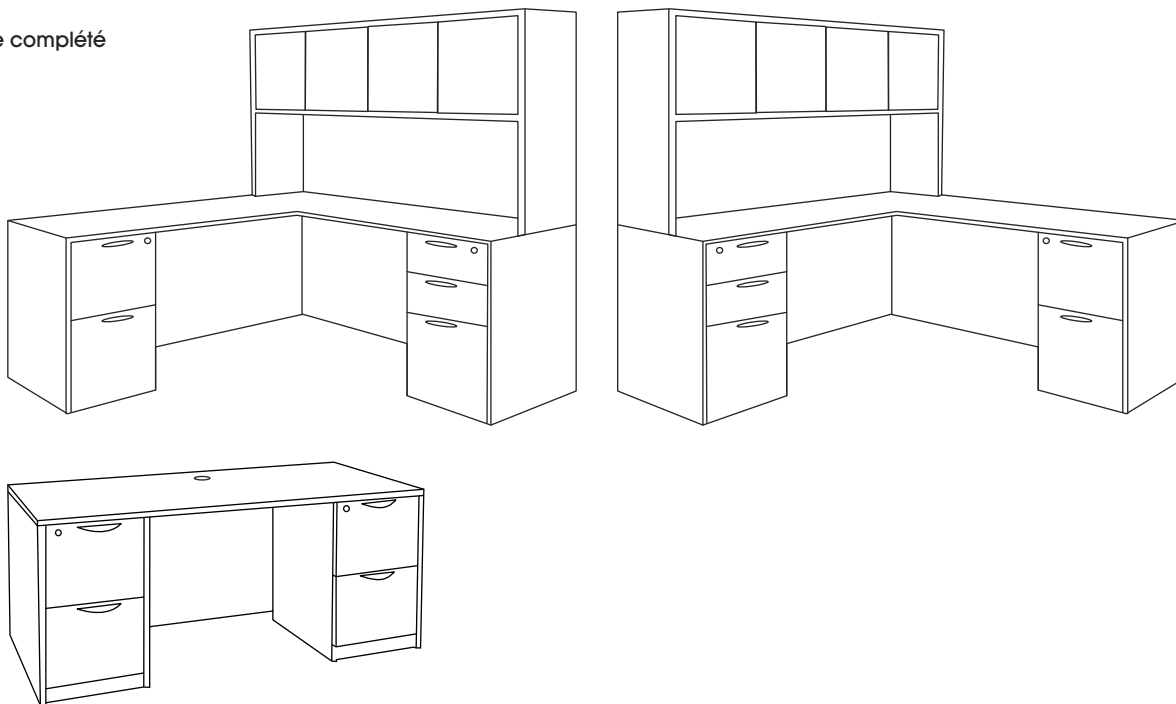

ULINE

1 800 295-5510
uline.ca