

**ULINE** H-6865, H-6866, H-6867  
H-6868, H-6870  
**DELUXE SHOP DESKS**

1-800-295-5510  
uline.com

**TOOLS NEEDED**

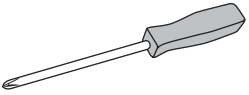

Phillips Screwdriver



10 mm Wrench



Two Person Assembly  
Recommended

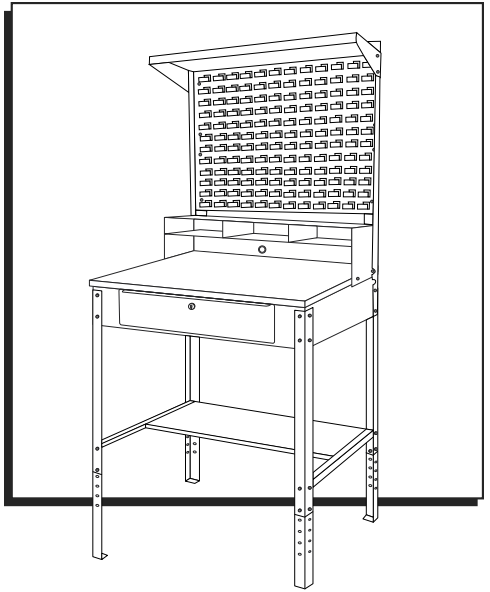

**PARTS**



Shop Desk assembly required first. Instructions  
located in Shop Desk carton.

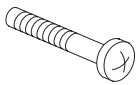

Long Bolt x 8



Short Bolt x 16



Flange Nut x 24

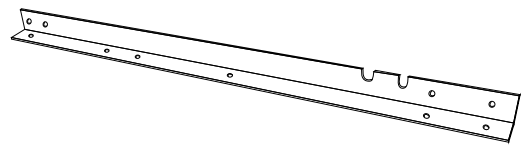

Upright x 2

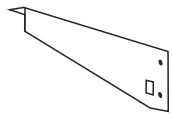

Shelf Bracket x 2

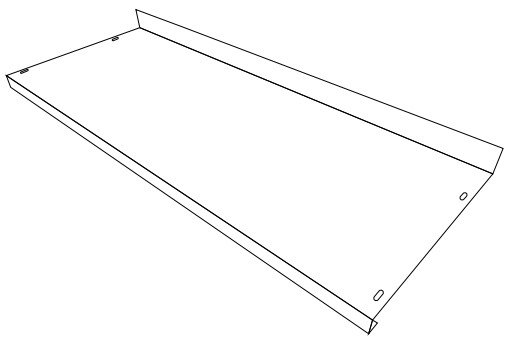

Shelf x 1

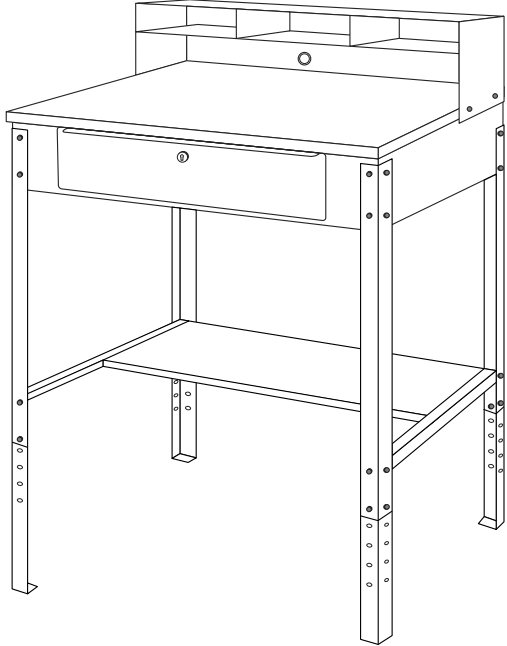

Assembled Shop Desk x 1

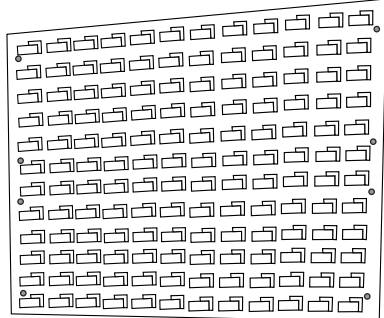
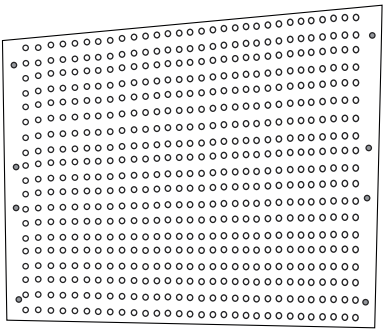

Pegboard Panel or Louvered Panel x 1

# INSTRUCTIONS

1. When shop desk is upright, remove hardware from one of the back legs. (See Figure 1)

 **NOTE:** Do not remove hardware from the other leg until instructed to do so.

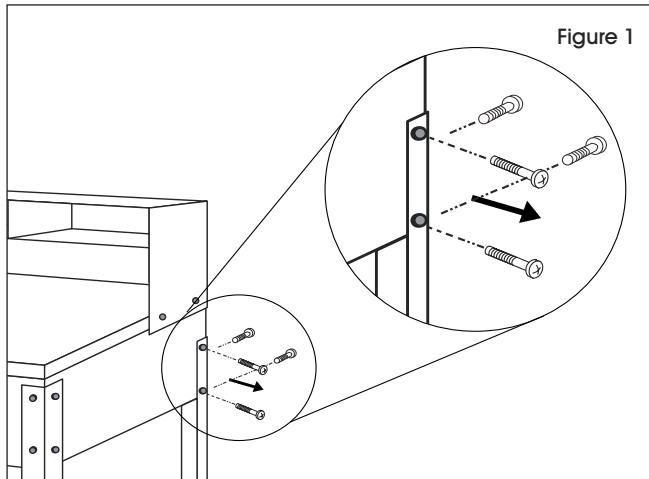

2. Align and attach uprights to leg and desk top using four long bolts and four flange nuts included in the upright hardware kit. (See Figure 2)

 **NOTE:** Make sure the two cutouts on upright are facing front of desk.

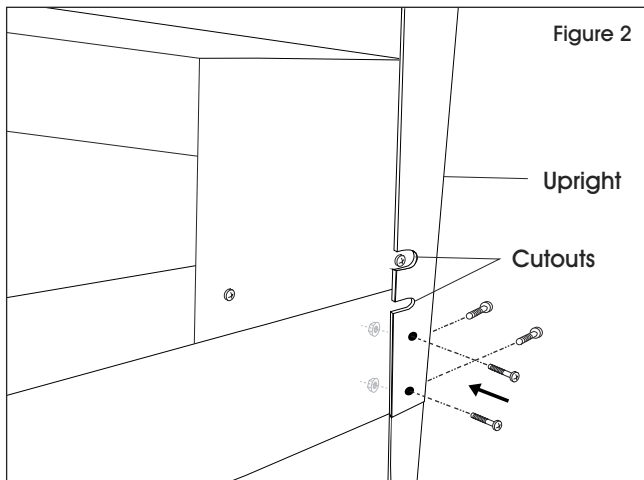

3. Repeat steps 1 and 2 for other back leg.

4. Align holes on panel to the four holes on each upright. Attach panel to uprights using eight short bolts and eight flange nuts. (See Figure 3)

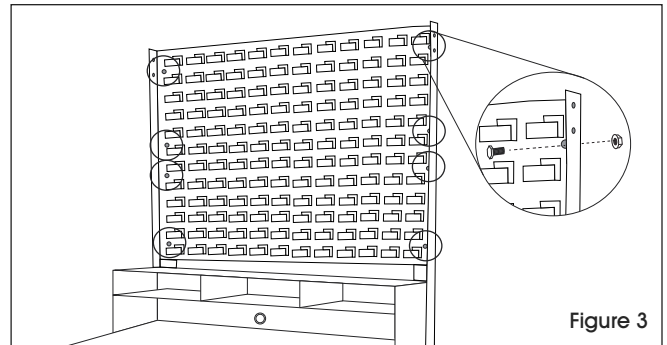

5. Line up shelf brackets with uprights and secure to uprights with four short bolts and four flange nuts. (See Figure 4)

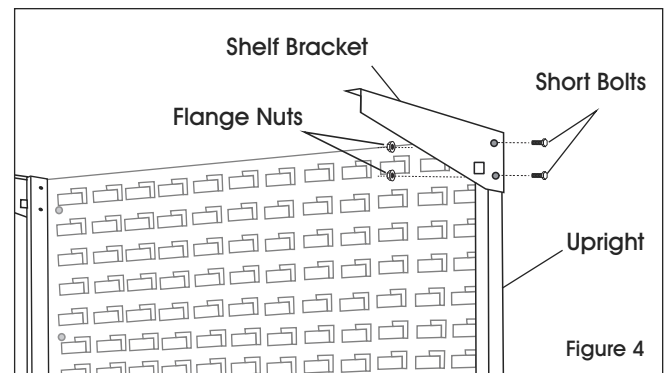

6. Place shelf on brackets. Install to brackets with four short bolts and four flange nuts. (See Figure 5)

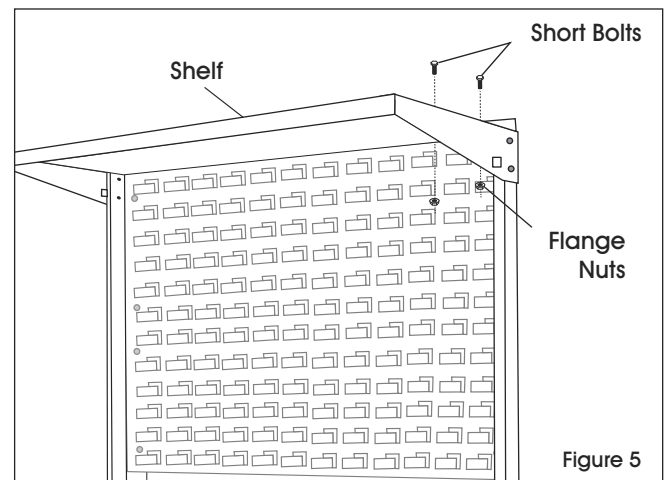

7. Recheck all bolts and nuts for tightness.

**ULINE**

1-800-295-5510  
uline.com

# ESCRITORIOS DE ALTA CALIDAD PARA TALLER

800-295-5510  
uline.mx

## HERRAMIENTAS NECESARIAS

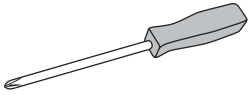

Desarmador de Cruz



Llave de 10 mm



Se recomienda Armar Entre Dos Personas

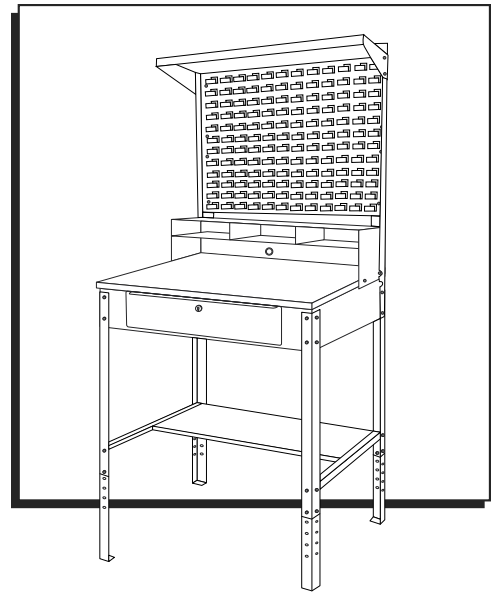

## PARTES



Se necesita primero ensamblar el Escritorio para Taller. Las instrucciones se encuentran en la caja del Escritorio para Taller.

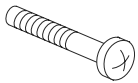

8 Pernos Largos



16 Pernos Cortos



24 Tuercas con Reborde

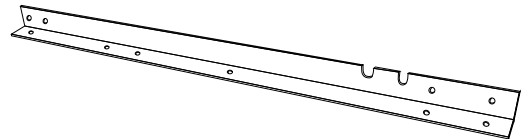

2 Postes

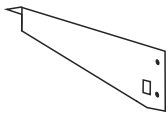

2 Soportes de Repisa

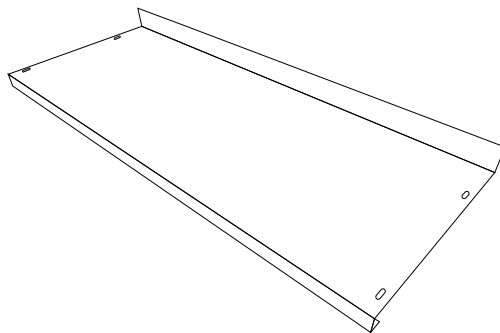

1 Repisas

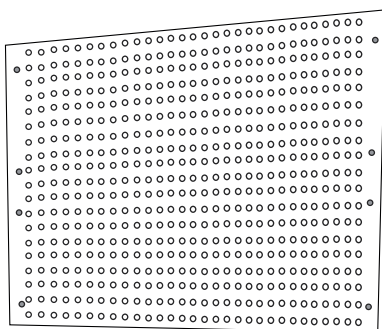

1 Tablero Perforado o Panel de Rejillas

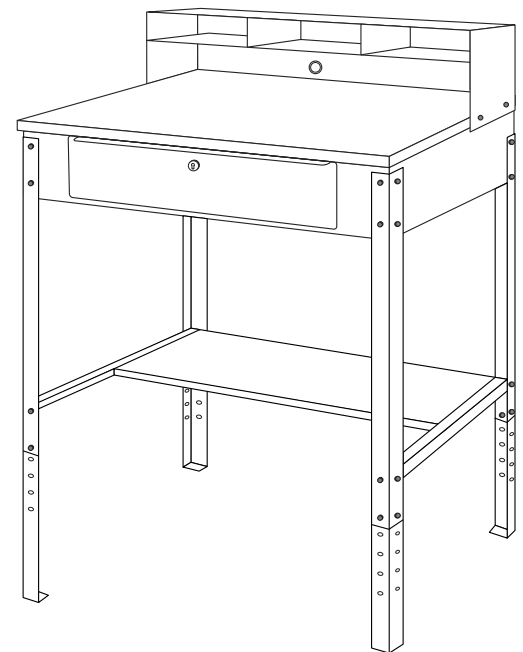
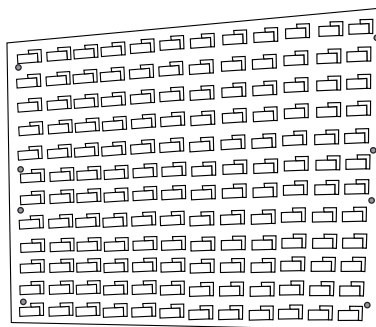

1 Escritorio para Taller Ensamblado

# INSTRUCCIONES

1. Cuando el escritorio para taller esté de pie, retire la tornillería de la parte posterior de las patas. (Vea Diagrama 1)

 **NOTA:** No retire la tornillería de la otra pata hasta que se le indique hacerlo.

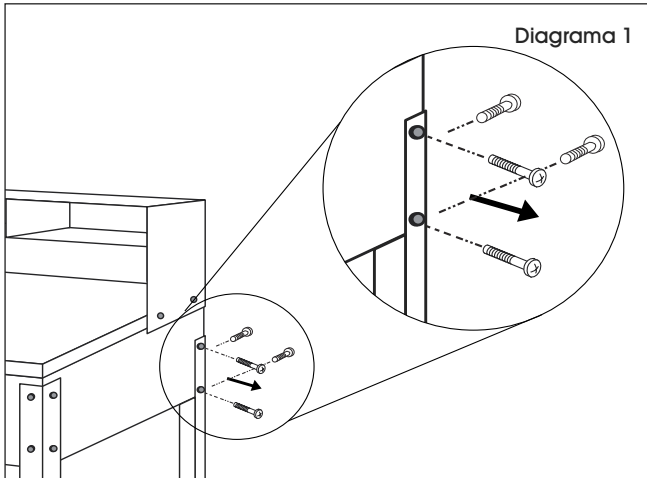

2. Alinee y acople los postes a las patas y la cubierta del escritorio usando cuatro pernos largos y cuatro tornillos con reborde incluidos en el kit de tornillería para el poste. (Vea Diagrama 2)

 **NOTA:** Asegúrese de que los dos recortes en posición vertical estén orientados hacia el frente del escritorio.

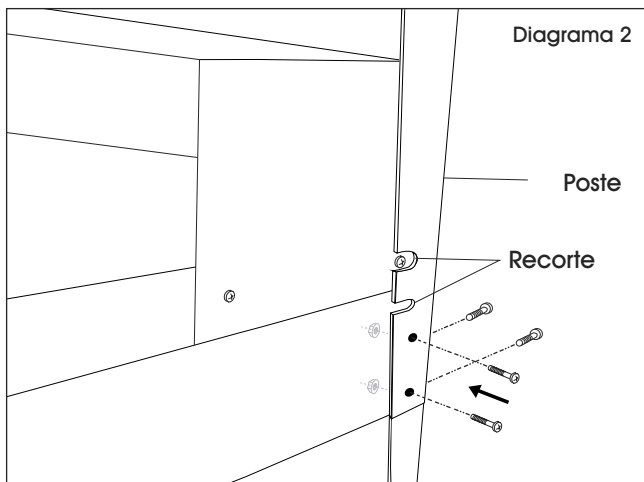

3. Repita los pasos 1 y 2 para la otra pata posterior.

4. Alinee los orificios del panel a los cuatro orificios en cada poste. Conecte el panel a los postes usando ocho pernos cortos y ocho tuercas con reborde. (Vea Diagrama 3)

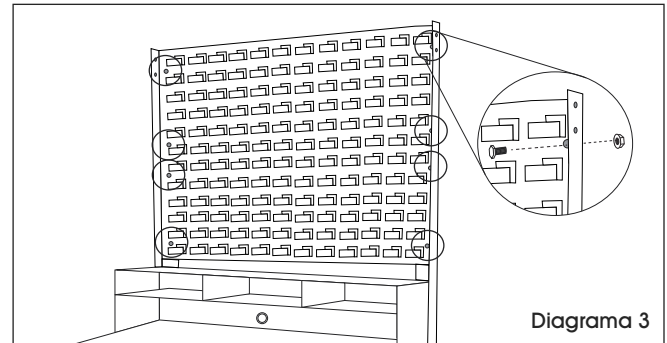

5. Alinee los soportes de la repisa con los postes y asegure los postes con cuatro pernos cortos y cuatro tuercas con reborde. (Vea Diagrama 4)

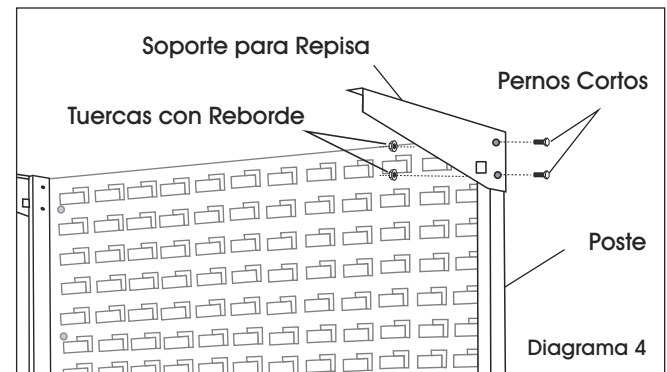

6. Coloque la repisa sobre los soportes. Instale a los soportes con cuatro pernos cortos y cuatro tuercas con reborde. (Vea Diagrama 5)

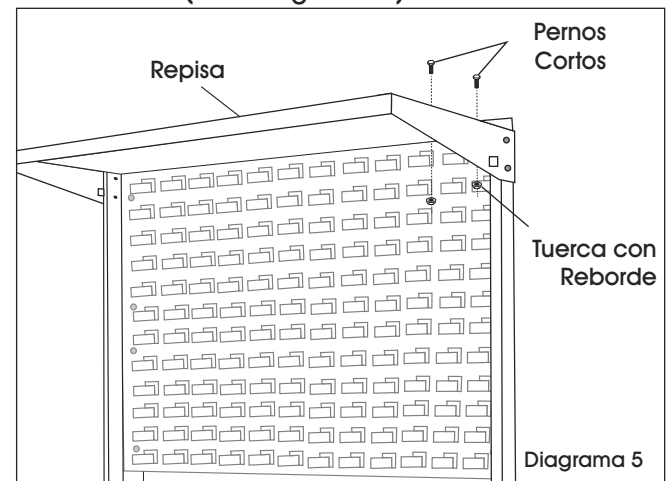

7. Verifique de nuevo que todos los pernos y tuercas estén apretados.

**ULINE**

800-295-5510  
uline.mx

**OUTILS REQUIS**

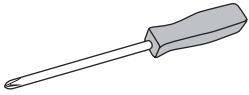

Tournevis cruciforme



Clé de 10 mm



Montage à deux personnes recommandé

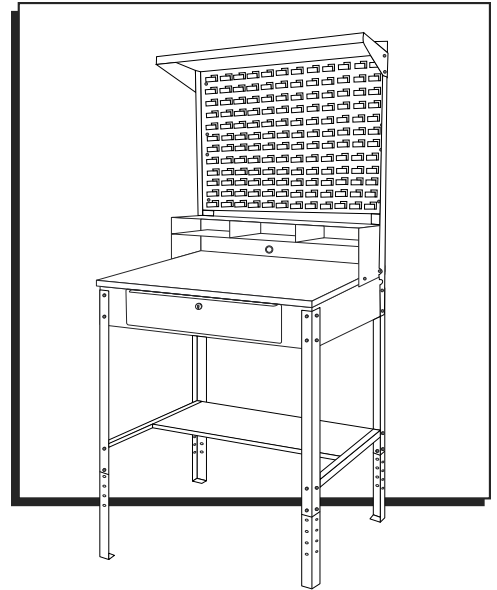

**PIÈCES**



Il est recommandé d'effectuer le montage du bureau d'atelier en premier. Les instructions se trouvent dans le carton d'emballage.

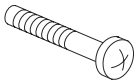

Long boulon x 8



Court boulon x 16



Écrou à embase x 24

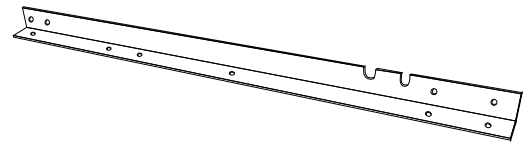

Montant x 2

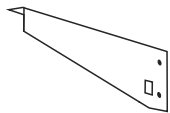

Console pour tablette x 2

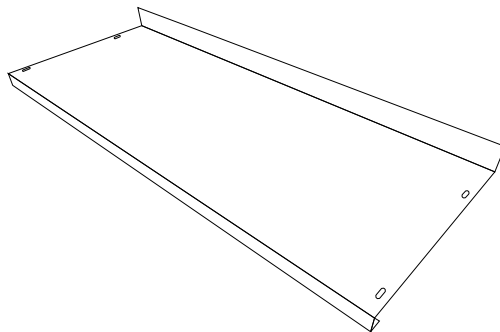

Tablette x 1

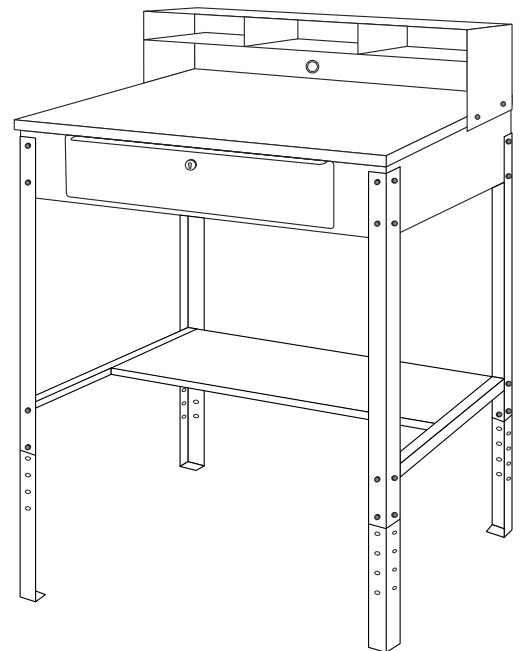

Bureau d'atelier complété x 1

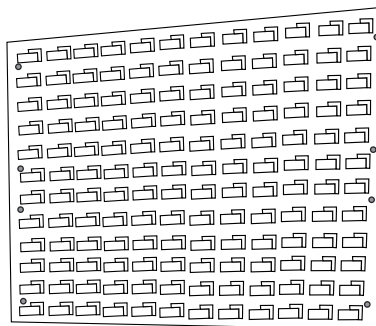
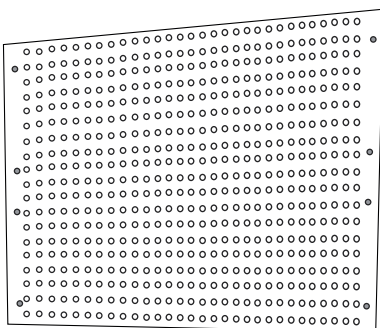

Panneau perforé ou panneau à fentes x 1

# INSTRUCTIONS

1. Lorsque le bureau d'atelier est à l'endroit, enlevez le matériel d'installation d'un des pieds arrière. (Voir Figure 1)

 **REMARQUE :** Ne retirez pas le matériel sur l'autre pied tant que vous n'en avez reçu l'instruction.

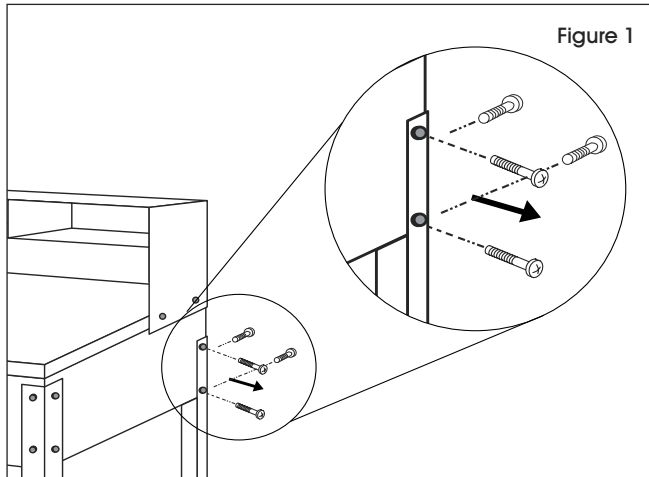

2. Alignez et fixez les montants aux pieds et au bureau à l'aide de quatre longs boulons et quatre écrous à embase inclus dans l'ensemble de matériel du montant. (Voir Figure 2)

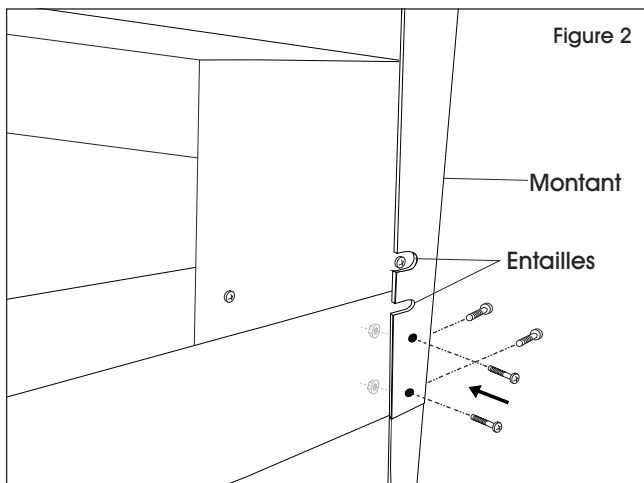

 **REMARQUE :** Assurez-vous que les deux entailles sur le montant sont orientées vers le devant du bureau.

3. Répétez les étapes 1 et 2 pour l'autre pied arrière.

4. Alignez les trous sur le panneau avec les quatre trous sur chacun des montants. Fixez le panneau aux montants à l'aide de huit courts boulons et huit écrous à embase. (Voir Figure 3)

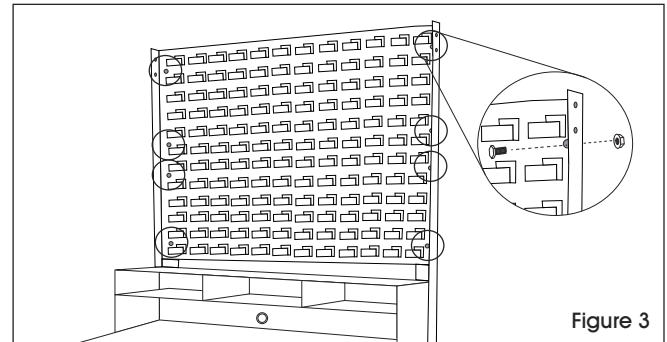

5. Alignez les consoles pour tablette avec les montants et fixez-les avec quatre courts boulons et quatre écrous à embase. (Voir Figure 4)

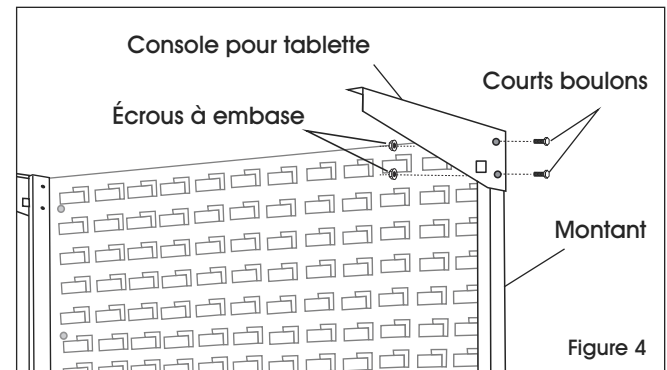

6. Placez les tablettes sur les consoles et fixez-les avec quatre courts boulons et quatre écrous à embase. (Voir Figure 5)

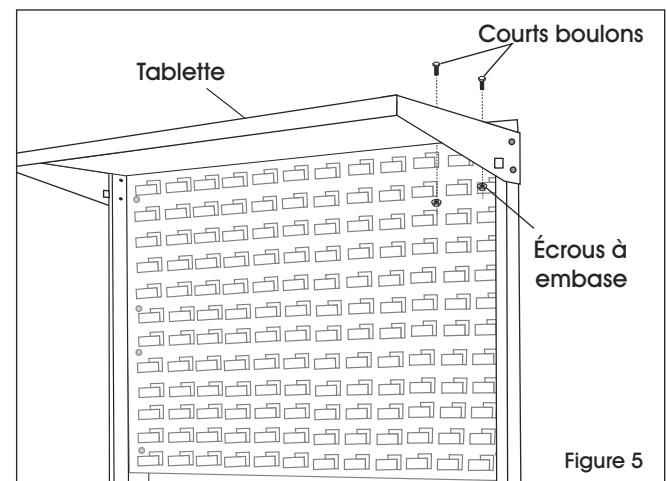

7. Revérifiez que tous les boulons et les écrous sont bien serrés.

**ULINE**

1-800-295-5510  
uline.ca