

TOOL NEEDED

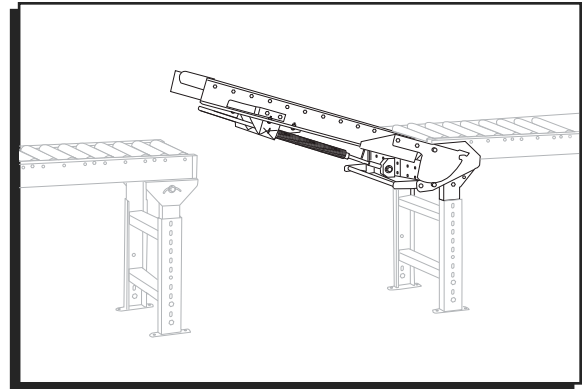

PARTS

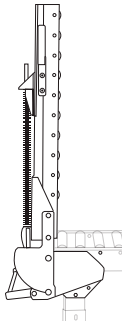

Gate x 1

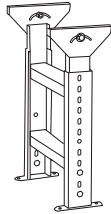

H-Stand x 4
(not included)

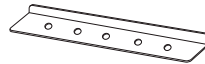

Steel Angle x 2

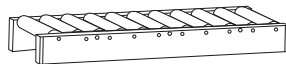

Gravity Roller x 2
(not included)



9/16" (14 mm) Nut x 8



Washer x 8

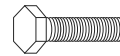

9/16" (14 mm) Bolt x 8



Split Washer x 8

INSTALLATION



NOTE: At least two people are needed to install gate.

1. While gate is at a 90° angle, line up bolt holes with H-stand holes. (See Figure 1)

2. Place gravity roller section on top of gate and line up with bolt holes in gate and H-stand. (See Figure 2)

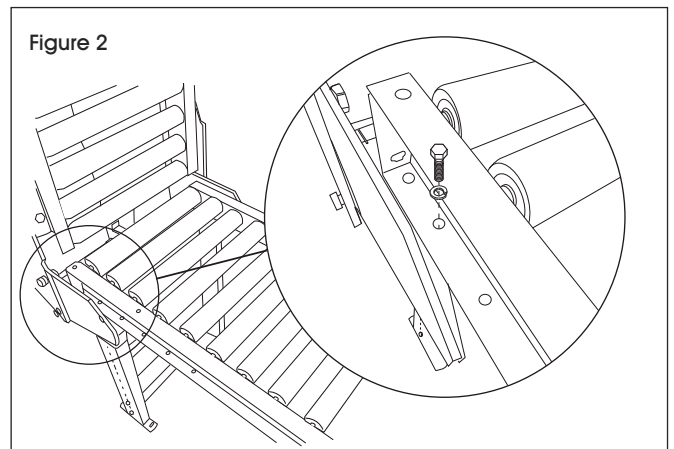
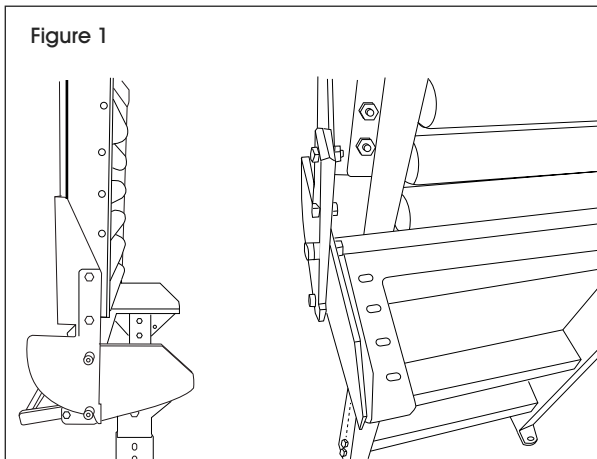

INSTALLATION CONTINUED

3. Insert two bolts with split washers into lined-up bolt holes and hand tighten with washers and nuts to secure. Repeat for opposite side. Once secured, use wrench to tighten. (See Figure 3)

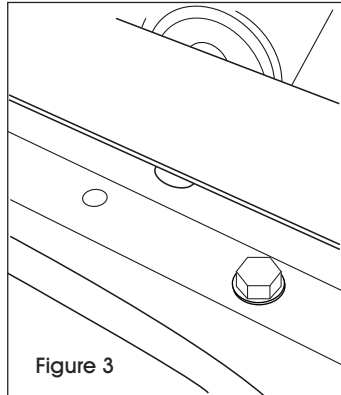

5. Lift gate lever to lower gate onto steel angle. (See Figure 6)

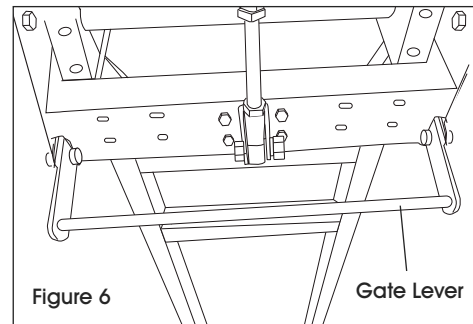

4. On second gravity roller section, line up steel angle holes with H-stand. The steel angle should overhang the H-stand. Place gravity roller on top and line up bolt holes. Insert two bolts with split washers into lined-up bolt holes and hand tighten with washers and nuts to secure. Repeat for opposite side. Once secured, use wrench to tighten. (See Figures 4-5)

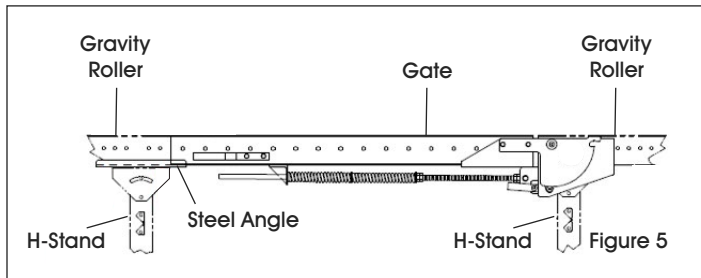
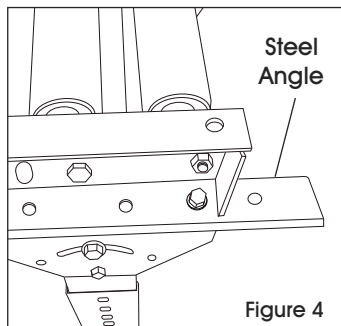

ULINE

1-800-295-5510
uline.com

PUERTAS PARA BANDA TRANSPORTADORA

HERRAMIENTA NECESARIA



Llave de 9/16" (14 mm)

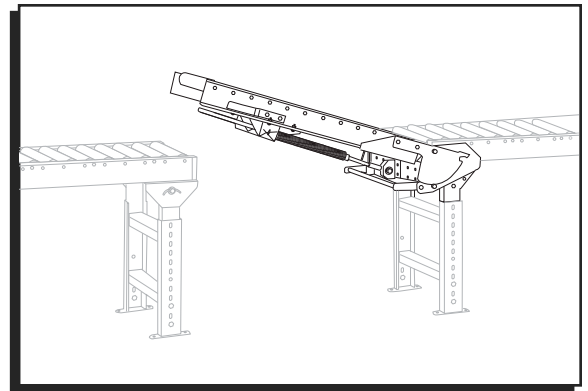

PARTES

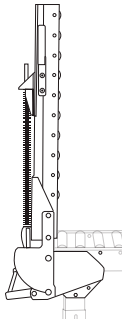

1 Puerta

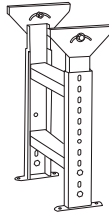
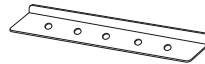
4 Soportes en H
(no incluidos)

2 Ángulos de Acero

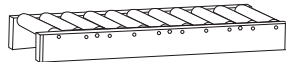
2 Sets de Rodillos por Gravedad
(no incluidos)

8 Tuercas de 9/16" (14 mm)



8 Rondanas

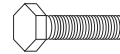

8 Pernos de 9/16" (14 mm)



8 Rondanas Partida

INSTALACIÓN



NOTA: Se necesitan al menos dos personas para instalar la puerta.

1. Coloque la puerta en un ángulo de 90° y alinee los orificios para pernos con los orificios del soporte en H. (Vea Diagrama 1)

2. Coloque la sección de rodillos por gravedad en la parte de encima de la puerta y alinéela con los orificios para pernos de la puerta y el soporte en H. (Vea Diagrama 2)

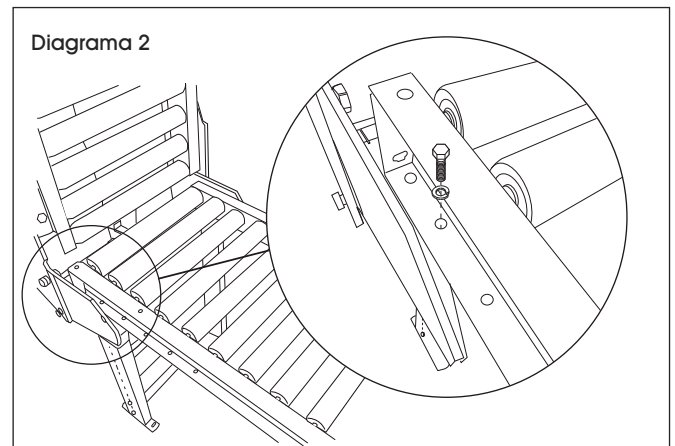
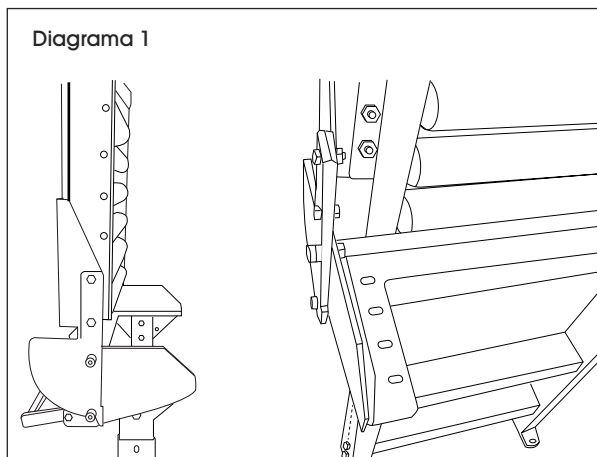

CONTINUACIÓN DE INSTALACIÓN

3. Inserte dos pernos con rondanas partidas en los orificios alineados para pernos y apriete con la mano con rondanas y tuercas para asegurarlos. Repita para el lado opuesto. Una vez asegurados, utilice la llave para apretarlos bien. (Vea Diagrama 3)

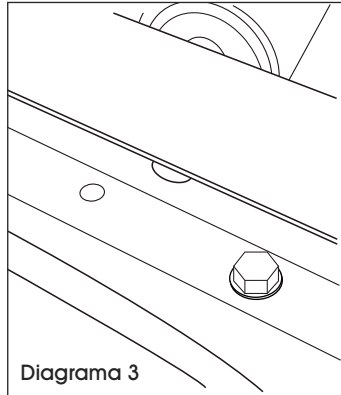

4. Para el segundo set de rodillos por gravedad, alinee los orificios del ángulo de acero con los del soporte en H. El ángulo de acero deberá sobresalir del soporte en H. Coloque el set de rodillos por gravedad encima y alinee los orificios para pernos. Inserte dos pernos con rondanas partidas en los orificios alineados para pernos y apriete con la mano con rondanas y tuercas para asegurarlos. Repita para el lado opuesto. Una vez asegurados, utilice la llave para apretarlos bien. (Vea Diagramas 4-5)

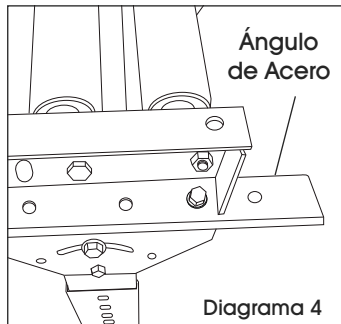

5. Levante la palanca de la puerta para bajarla hacia el ángulo de acero. (Vea Diagrama 6)

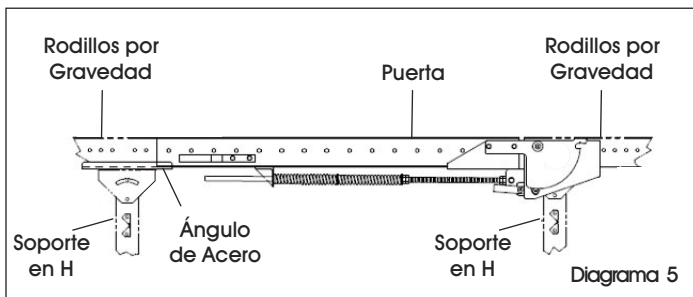
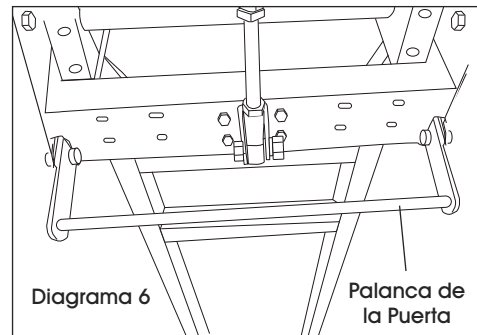

ULINE

800-295-5510
uline.mx

PORTILLONS POUR CONVOYEURS

OUTIL REQUIS

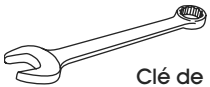

Clé de 14 mm (9/16 po)

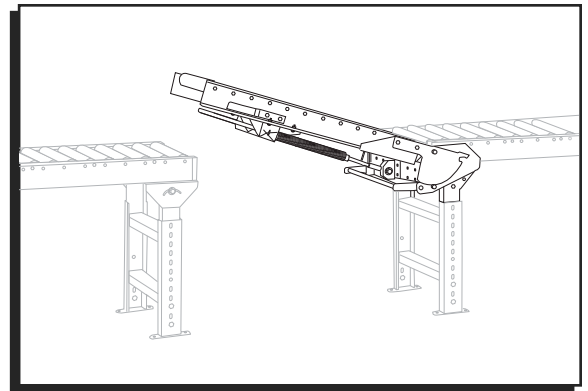

PIÈCES

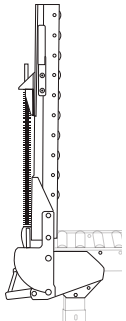

Portillon x 1

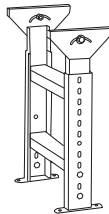

Pied de soutien en H x 4
(non inclus)

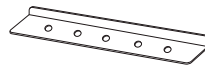

Cornière en acier x 2

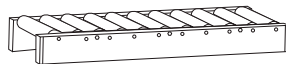

Rouleau par gravité x 2
(non inclus)



Écrou de 9/16 po x 8



Rondelle x 8

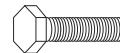

Boulon de 9/16 po x 8



Rondelle fendue x 8

INSTALLATION



REMARQUE : Il est recommandé que l'installation soit effectuée par au moins deux personnes.

1. Avec le portillon orienté à 90 °, alignez les trous de boulons sur les trous du pied de soutien en H. (Voir Figure 1)

2. Placez une section des rouleaux par gravité sur le portillon, puis alignez les trous de boulons du portillon sur ceux des pieds de soutien en H. (Voir Figure 2)

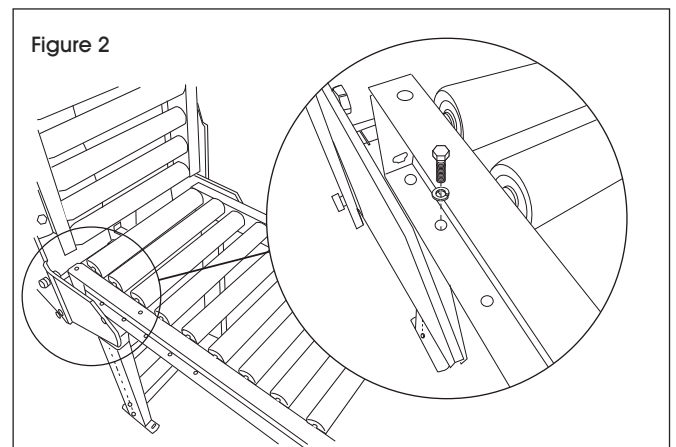
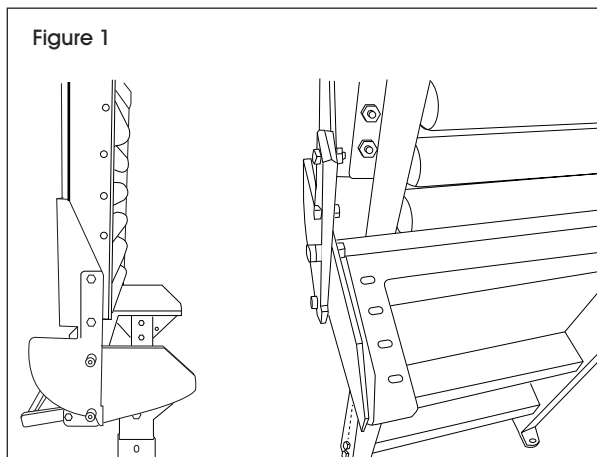

INSTALLATION SUITE

3. Insérez deux boulons avec rondelles fendues dans les trous de boulons alignés et serrez à la main avec des écrous et des rondelles pour sécuriser. Répétez l'opération de l'autre côté. Lorsque tout est bien fixé, serrez le tout à l'aide de la clé. (Voir Figure 3)

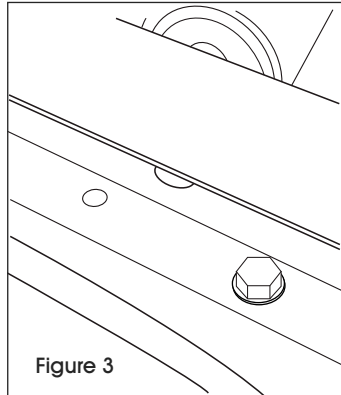

4. Sur la deuxième section de rouleaux par gravité, alignez les trous de cornière sur le pied de soutien en H. La cornière en acier doit surplomber le pied de soutien en H. Placez-y le rouleau par gravité, puis alignez les trous de boulons.

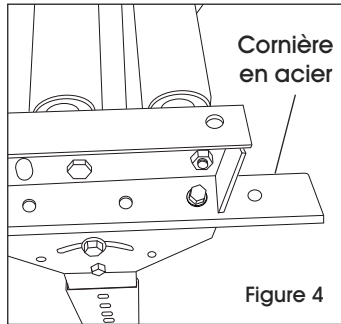

Insérez deux boulons avec rondelles fendues dans les trous de boulons alignés et serrez à la main avec des écrous et des rondelles pour sécuriser. Répétez l'opération de l'autre côté. Lorsque tout est bien fixé, serrez le tout à l'aide de la clé. (Voir Figure 4-5)

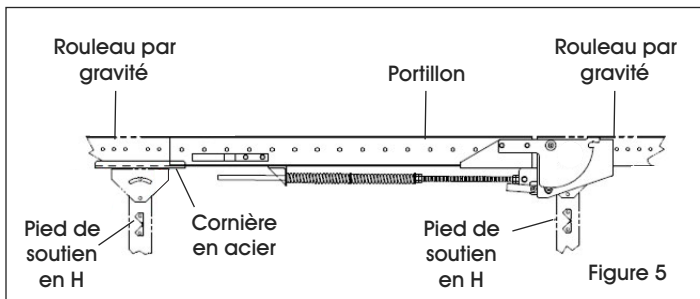

5. Soulevez le levier de portillon pour abaisser le portillon dans la cornière en acier. (Voir Figure 6)

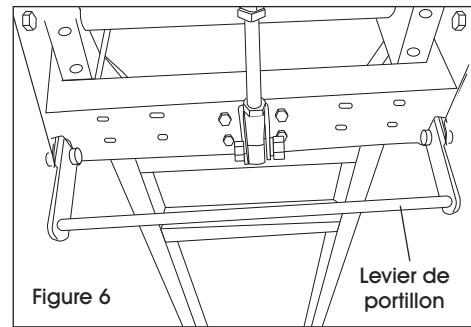

ULINE

1-800-295-5510
uline.ca