

# ULINE H-6966, H-6967, H-6968 H-6969, H-10142 BAR HEIGHT TABLE

1-800-295-5510  
uline.com

## TOOLS NEEDED

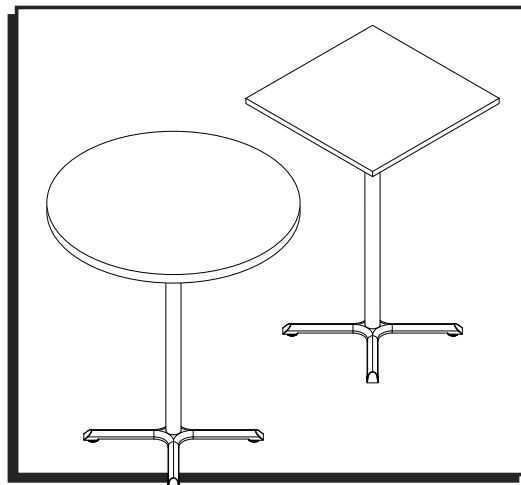
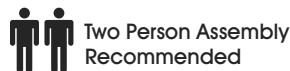

## PARTS

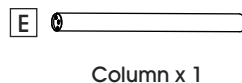
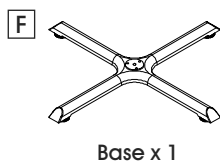
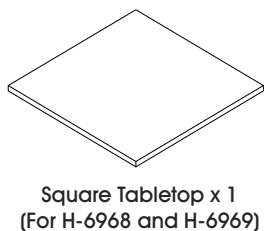
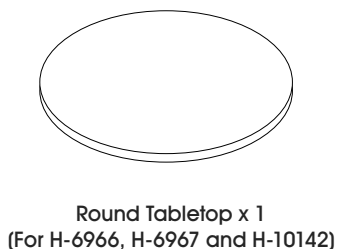

## ASSEMBLY

 **NOTE:** Use Allen wrench to tighten bolts (A). Use Phillips screwdriver to tighten screws (B).

 **NOTE:** Assemble on a smooth, non-marring surface to avoid scratching.

- Check that all parts are included.
- Instructions are identical for tables with square tops and tables with round tops.

1. Align tabletop mounting plate (D) with holes on column (E). Use three M8 x 35 mm bolts (A), three locking washers and three washers to secure base to center post. Fully tighten using an Allen wrench. (See Figure 1)

 **NOTE:** Both ends of column (E) are identical. Attach tabletop mounting plate (D) to either end of column.

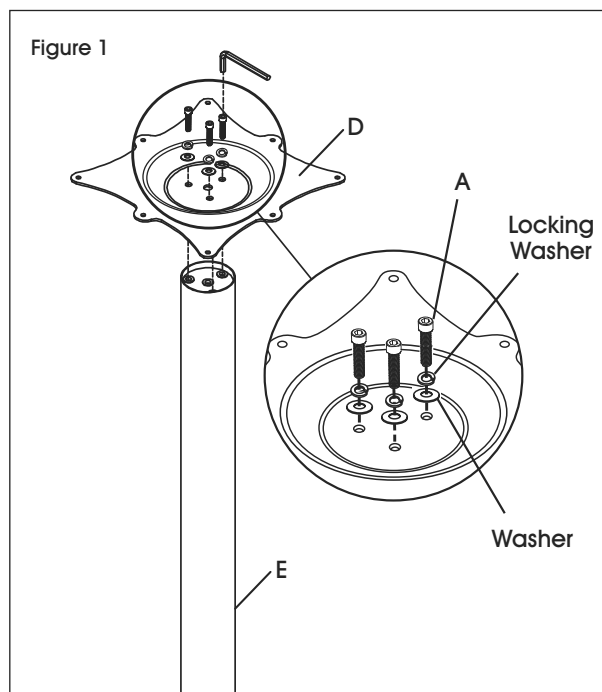

## ASSEMBLY CONTINUED

- Align base (F) with holes on open end of column (E). Use three M8 x 35 mm bolts (A), three locking washers and three washers to secure base to center post. Fully tighten using an Allen wrench. (See Figure 2)

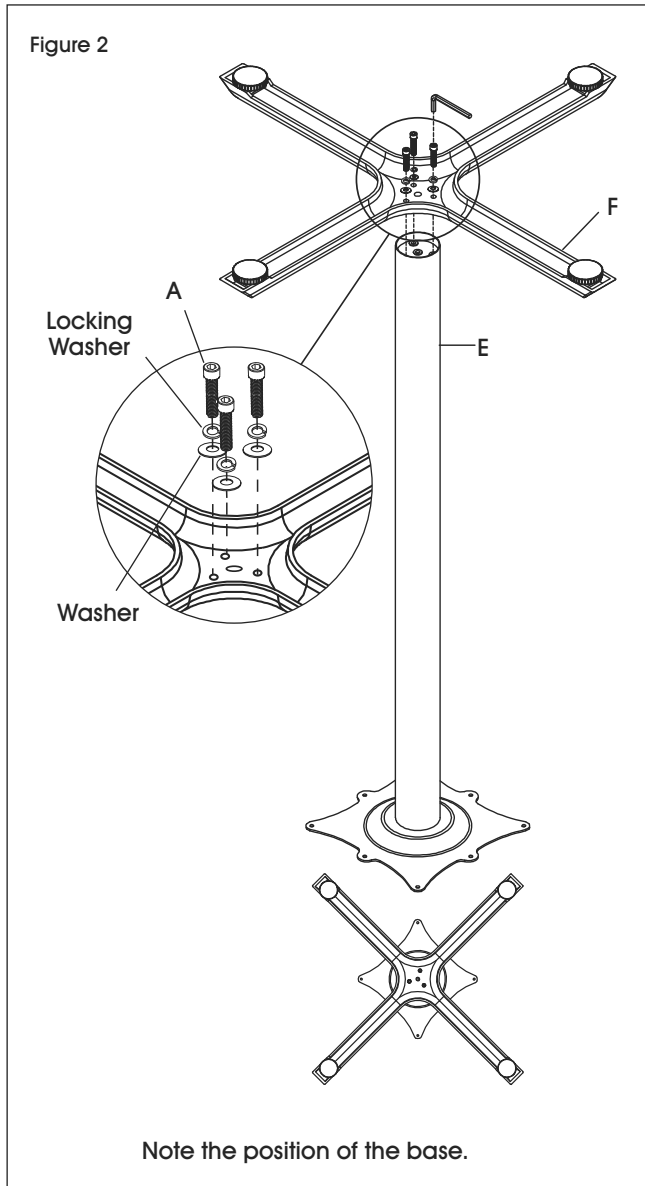

- Place tabletop (G) upside down. With second person, align tabletop mounting plate (D) from assembled base with holes in tabletop. With second person holding assembled base in place, use eight M5 x 25 mm screws (B) to secure mounting plate to tabletop. (See Figure 3)

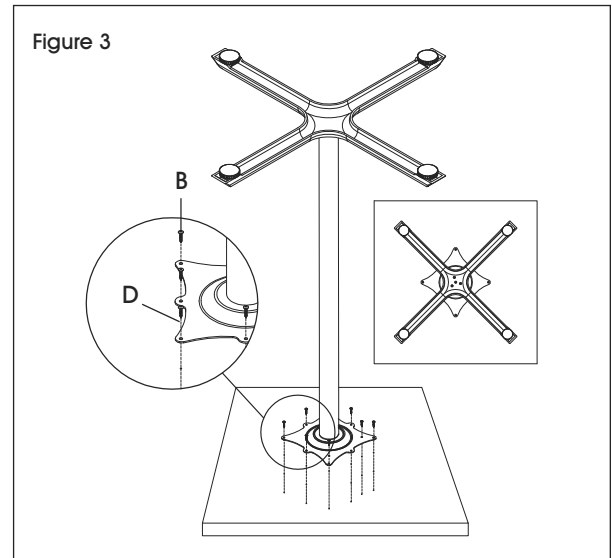

- With second person, set table upright. Adjust leveling feet to compensate for uneven floors.

### Completed Assembly

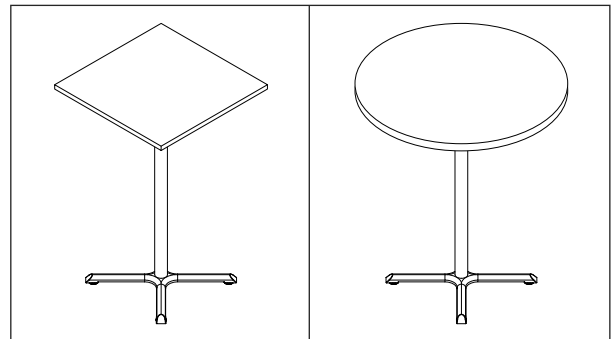

**ULINE**

1-800-295-5510

uline.com



H-6966, H-6967, H-6968  
H-6969, H-10142

800-295-5510  
uline.mx

# MESA ALTA

## HERRAMIENTAS NECESARIAS

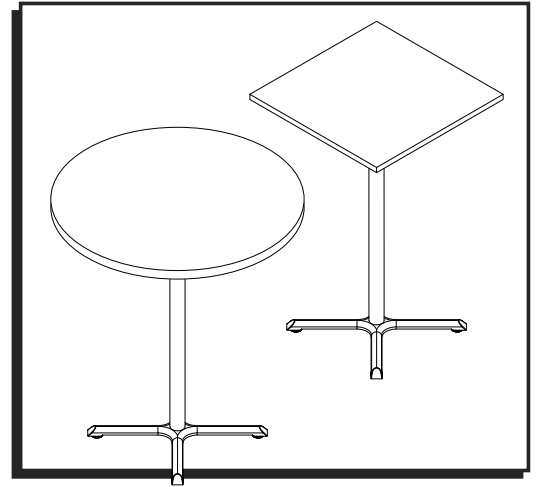

## PARTES

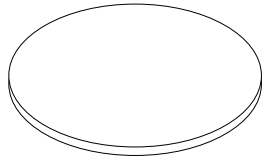

1 Cubierta Redonda  
(Para H-6966, H-6967 y H-10142)

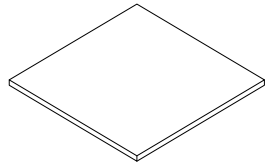

1 Cubierta Cuadrada  
(Para H-6968 y H-6969)

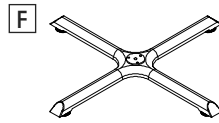

1 Base

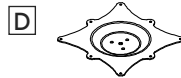

1 Placa de Instalación para Cubierta de Mesa

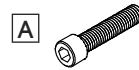

6 Pernos M8 x 38 mm

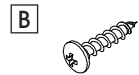

8 Tornillos M5 x 25 mm

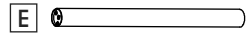

1 Columna



6 Rondanas de Seguridad



6 Rondanas

## ENSAMBLE

**NOTA:** Utilice la llave Allen para apretar todos los tornillos (A). Utilice un desarmador de cruz para apretar los tornillos (B).

**NOTA:** Ensamble sobre una superficie lisa que no deje marcas para evitar rayones.

- Verifique que todas las partes estén incluidas.
- Las instrucciones son idénticas para las mesas con cubiertas cuadradas y con cubiertas redondas.

1. Alinee la placa de instalación para cubierta de mesa (D) con los orificios en la columna (E). Use tres pernos M8 x 35 mm (A), tres rondanas de seguridad y tres rondanas para fijar la base al poste central. Apriete por completo usando la llave Allen. (Vea Diagrama 1)

**NOTA:** Ambos extremos de la columna (E) son idénticos. Fije la placa de instalación para cubierta (D) a cualquiera de los extremos de la columna.

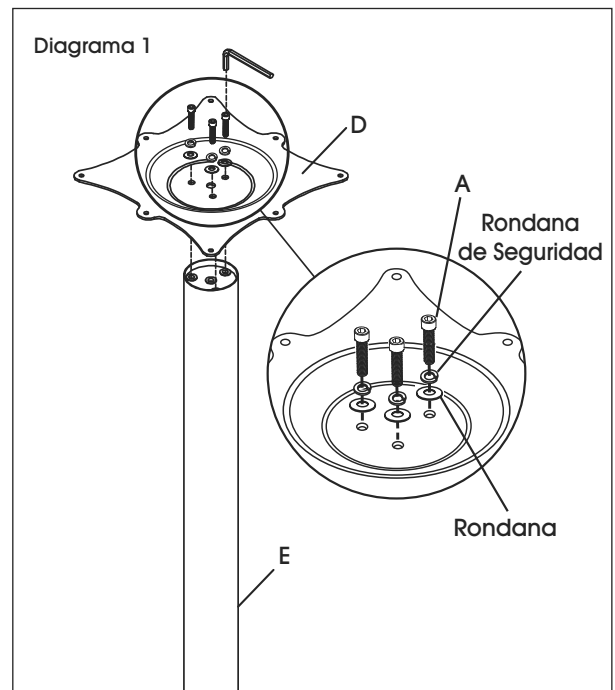

## CONTINUACIÓN DEL ENSAMBLE

2. Alinee la base (F) con los orificios en el extremo abierto de la columna (E). Use tres pernos M8 x 35 mm (A), tres rondanas de seguridad y tres rondanas para fijar la base al poste central. Apriete por completo usando la llave Allen. (Vea Diagrama 2)

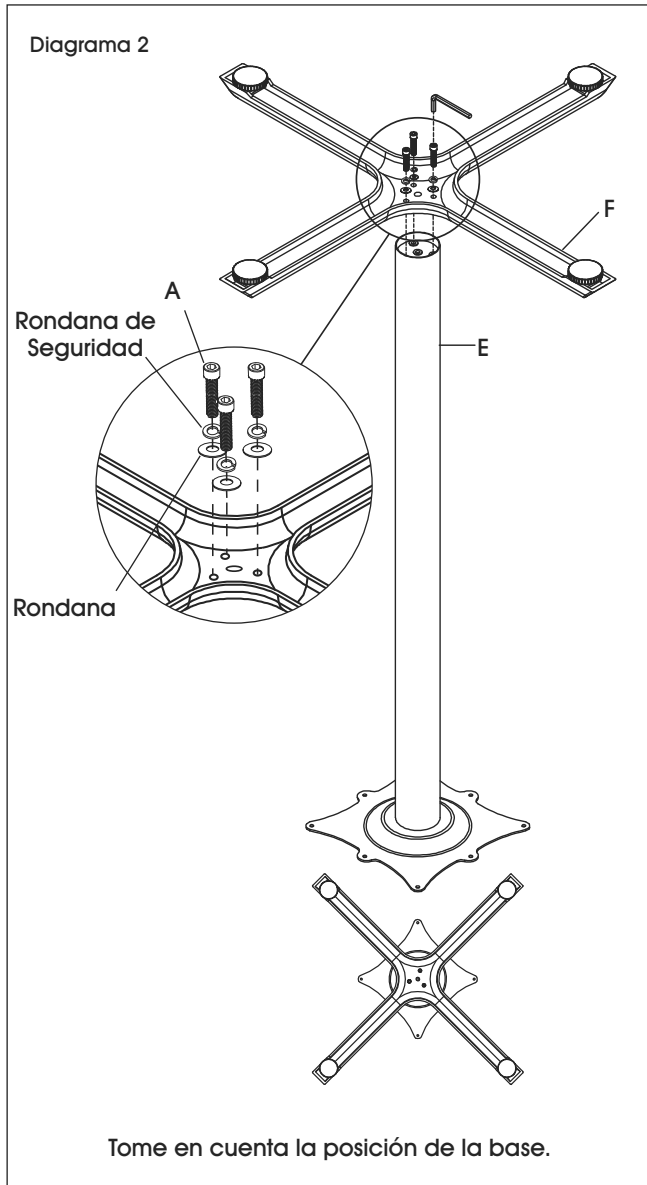

3. Coloque la cubierta (G) boca abajo. Con ayuda de otra persona, alineen la placa de instalación para cubierta de mesa (D) de la base ensamblada con los orificios en la cubierta. La otra persona debe sostener la base ensamblada en su lugar, use ocho tornillos M5 x 25 mm (B) para fijar la placa de instalación a la cubierta. (Vea Diagrama 3)

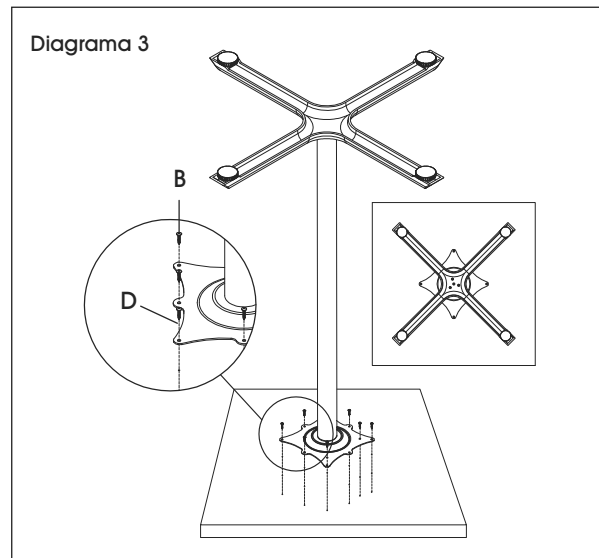

4. Con la ayuda de la otra persona, enderece la mesa. Ajuste las patas niveladoras para compensar el desnivel en el piso.

Ensamble Terminado

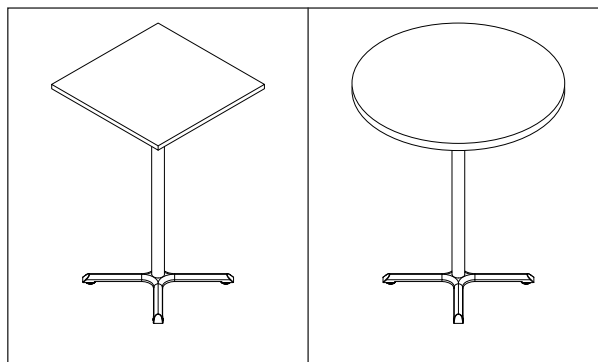

**ULINE**

800-295-5510  
uline.mx

## TABLE HAUTE DE BAR

### OUTILS REQUIS

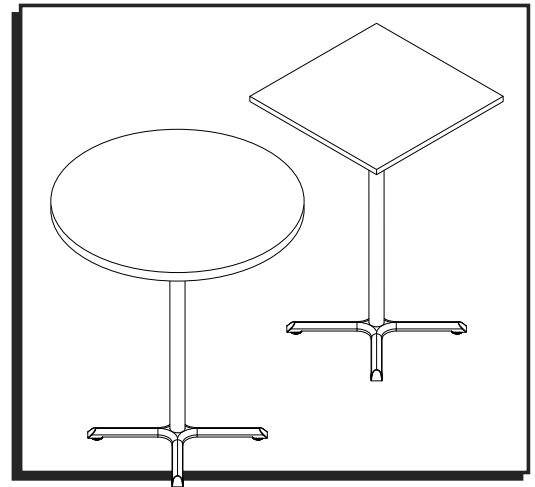
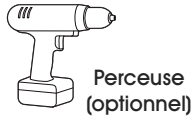
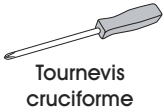

### PIÈCES

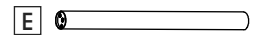
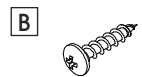
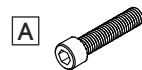
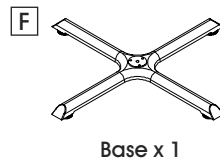
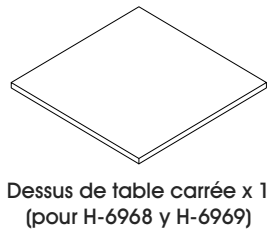
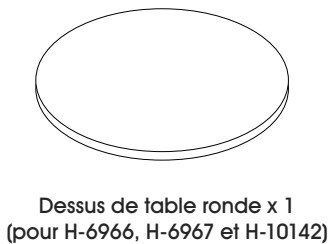

### MONTAGE

**REMARQUE :** Utilisez la clé Allen pour serrer les boulons (A). Utilisez le tournevis cruciforme pour serrer les vis (B).

**REMARQUE :** Montez la table sur une surface lisse qui ne marque pas afin d'éviter les rayures.

- Vérifiez que toutes les pièces sont incluses.
- Les instructions sont identiques pour les tables carrées et les tables rondes.

1. Alignez la plaque de fixation du dessus de table (D) sur les trous de la colonne (E). Utilisez trois boulons M8 x 35 mm (A), trois rondelles de blocage et trois rondelles pour fixer la base au montant central. Serrez complètement avec une clé Allen. (Voir Figure 1)

**REMARQUE :** Les deux extrémités de la colonne (E) sont identiques. Fixez la plaque de fixation du dessus de table (D) à l'une des extrémités de la colonne.

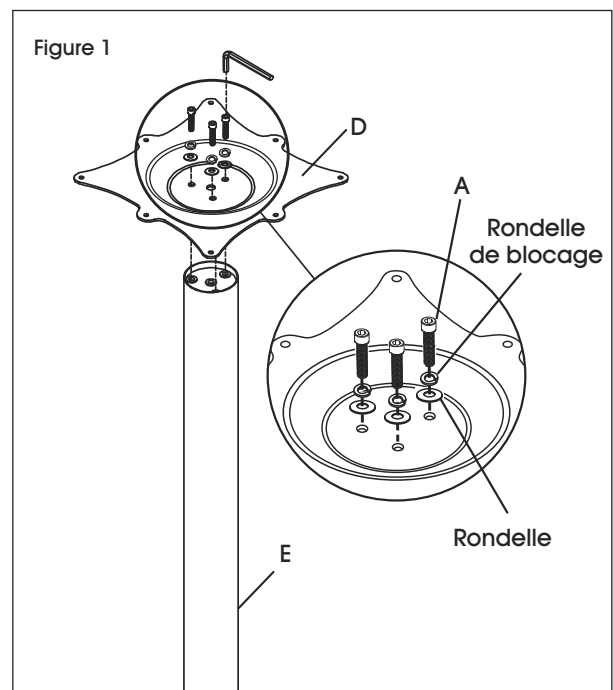

## MONTAGE SUITE

- Alignez la base (F) sur les trous de l'extrémité ouverte de la colonne (E). Utilisez trois boulons M8 x 35 mm (A), trois rondelles de blocage et trois rondelles pour fixer la base au montant central. Serrez complètement avec une clé Allen. (Voir Figure 2)

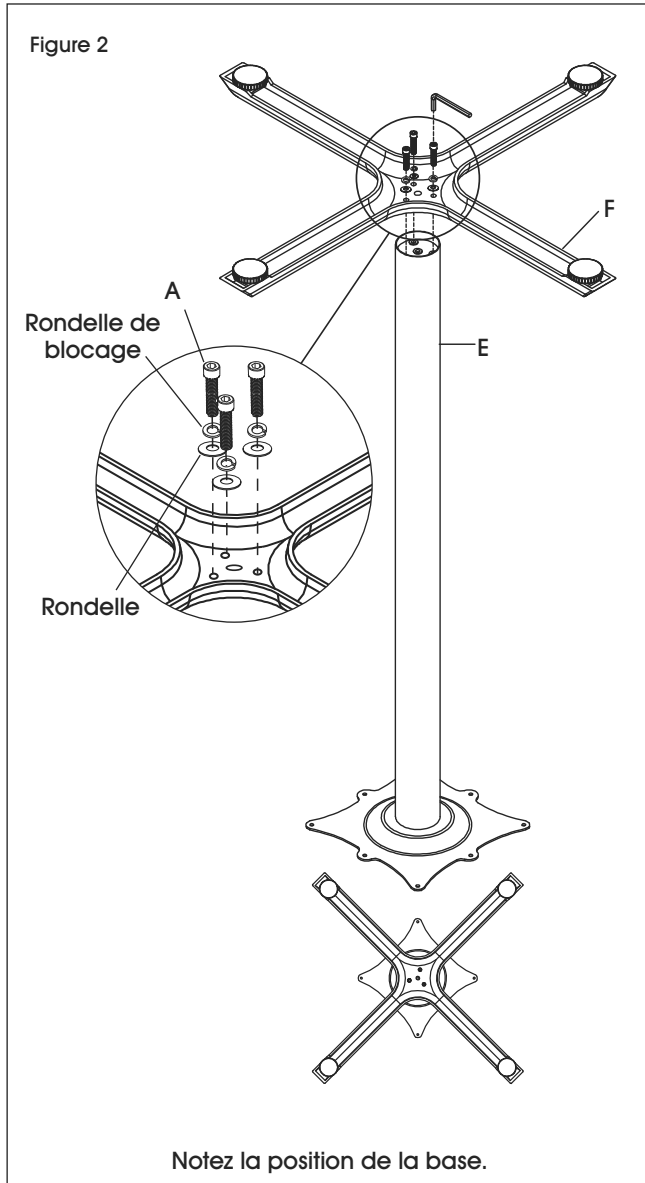

- Placez le dessus de table (G) à l'envers. À deux, alignez la plaque de fixation du dessus de table (D) de la base assemblée sur les trous du dessus de table. Pendant que la deuxième personne tient la base assemblée en place, utilisez huit vis M5 x 25 mm (B) pour fixer la plaque de fixation sur le dessus de table. (Voir Figure 3)

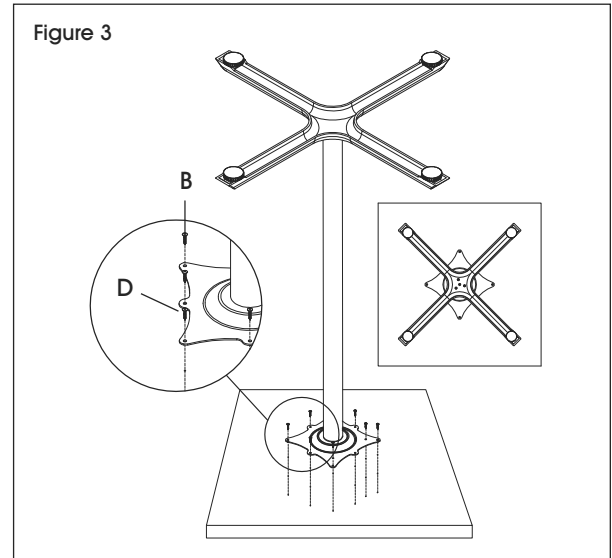

- À deux, mettez la table à l'endroit. Ajustez les pieds de nivellement pour compenser les inégalités du sol.

Montage complété

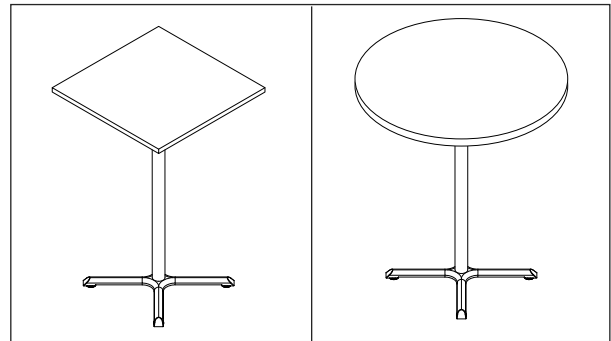

**ULINE**

1 800 295-5510  
uline.ca