

# ULINE H-6991

## DELUXE VINYL WORK STOOL WITH ADJUSTABLE ARMS

1-800-295-5510  
uline.com

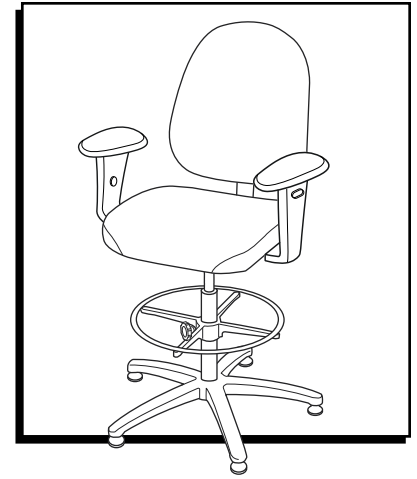

### TOOL NEEDED

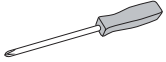

Phillips Screwdriver

### PARTS

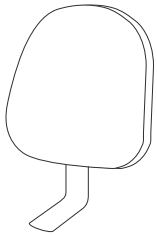

Back Cushion  
with Post x 1

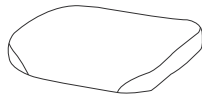

Seat Cushion x 1

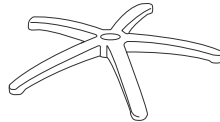

5-Star Base x 1



Glide x 5

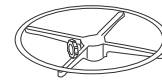

Footring x 1



Gas Lift x 1



Armrest Mounting  
Bracket x 2

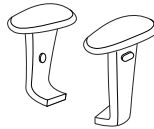

Armrest x 2



Bolt x 8



Washer x 8



Armrest Knob x 2

### ASSEMBLY

1. Insert glides into legs of five-star base. Turn base upright. Insert gas lift into center of base. (See Figure 1)

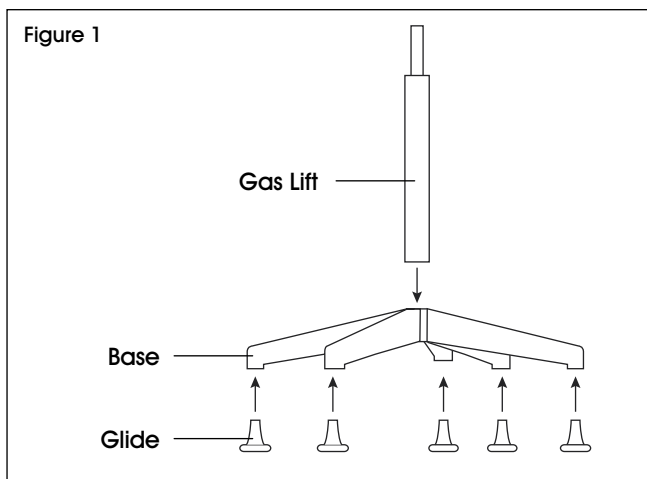

2. Find the threaded holes under the fabric cover on bottom of seat cushion. (Run hand over the fabric cover to locate holes.) Use screwdriver to gently pierce fabric at each hole. (See Figure 2)

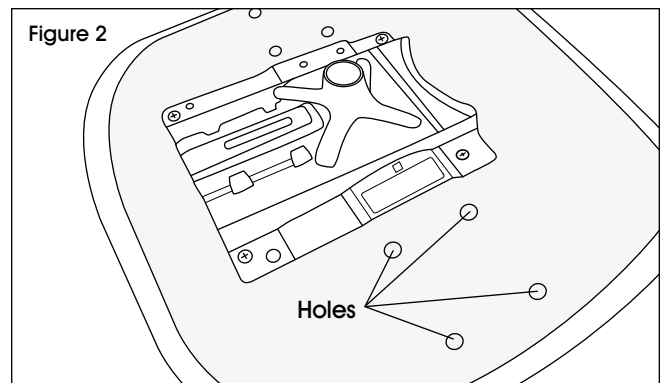

## ASSEMBLY CONTINUED

- Align armrest mounting bracket with holes on seat cushion and use four bolts with washers to attach. Insert armrest into mounting bracket and use armrest knob to secure. Repeat on opposite side. (See Figure 3)

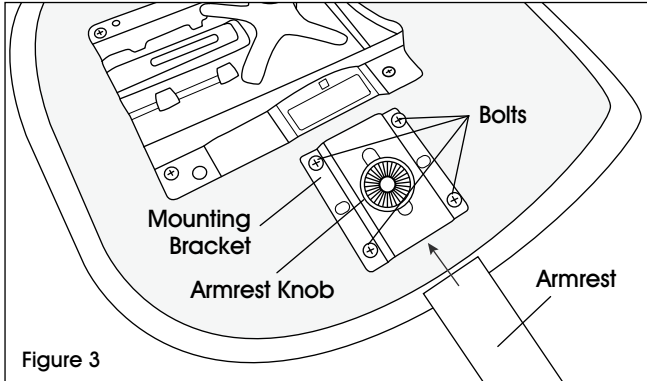

- Insert back cushion post into corresponding slot in mechanism on bottom of seat. Tighten knob to secure. (See Figure 4)

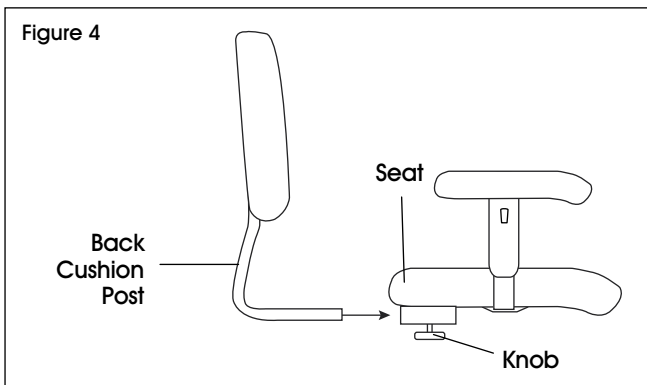

- Slide footring onto the gas lift and tighten knob to secure. (See Figure 5)

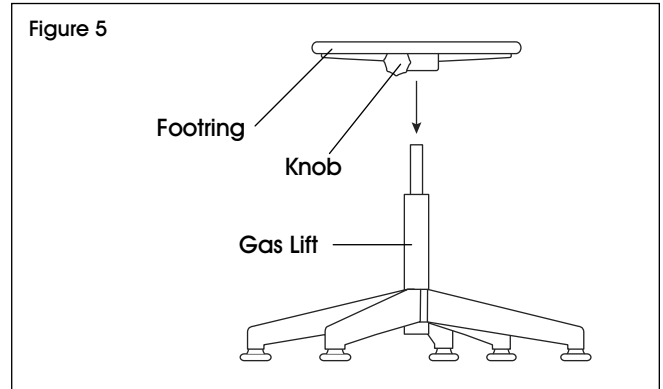

- Slowly lower stool assembly onto the gas lift. Press down on seat to secure. (See Figure 6)

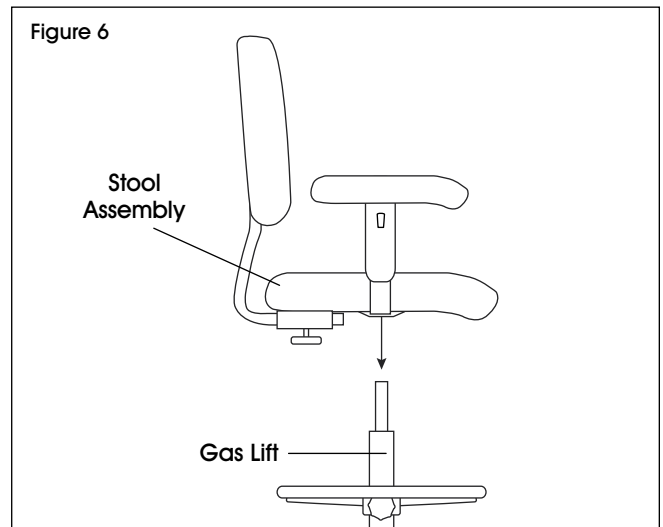

## STOOL ADJUSTMENTS

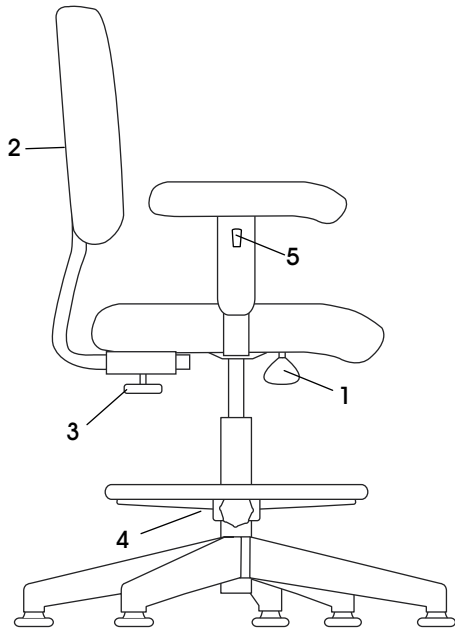

1. **Seat Height Adjustment** – To raise seat height, lift lever up with little to no weight on the seat. To lower seat height, lift lever up while sitting.
2. **Back Height** – To raise the back, lift the back cushion until it clicks into the desired height. To lower the back, lift the back cushion to its tallest height to release ratchet mechanism, then push it down to the lowest height setting.
3. **Seat Depth** – To adjust seat depth, loosen knob and slide the back in or out. Set back at your preferred seat depth and tighten knob to secure.
4. **Footring Height** – To adjust footring height, loosen knob and slide the footring up or down. Set footring at your preferred height and tighten knob to secure.
5. **Armrest Height Adjustment** – To adjust arm height, press the button on the side of each armrest and move the arm up or down.

**ULINE**

1-800-295-5510  
uline.com

**ULINE** H-6991

# SILLA DE TRABAJO DE VINIL DE ALTA CALIDAD CON DESCANSABRAZOS AJUSTABLES

800-295-5510

uline.mx

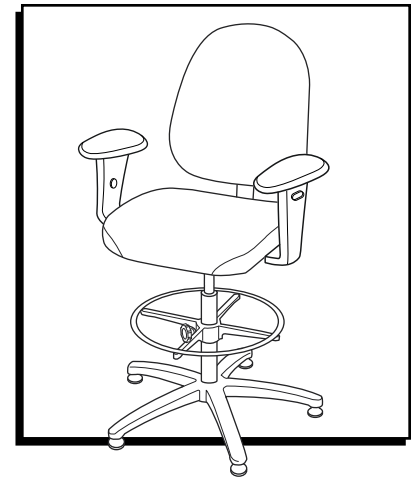

## HERRAMIENTA NECESARIA

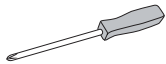

Desarmador de Cruz

## PARTES

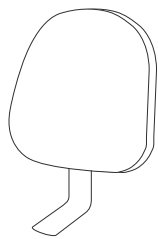

1 Respaldo con Poste

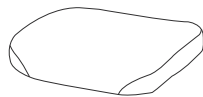

1 Asiento



1 Base Estrella



5 Niveladores

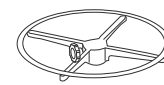

1 Reposapiés



1 Pistón de Gas



2 Soportes para Instalación de Descansabrazos

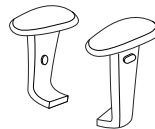

2 Descansabrazos



8 Pernos



8 Rondanas



2 Perillas para Descansabrazos

## ENSAMBLE

1. Inserte los niveladores en las patas de la base estrella. Enderece la base. Inserte el pistón de gas en el centro de la base. (Vea Diagrama 1)

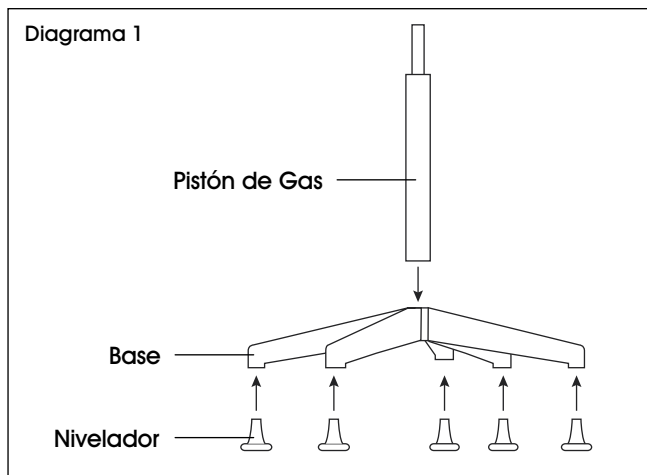

2. Encuentre los orificios roscados debajo de la cubierta de tela del asiento. (Recorra con la mano la cubierta de tela para ubicar los orificios). Utilice un desarmador para perforar con cuidado cada orificio en la tela. (Vea Diagrama 2)

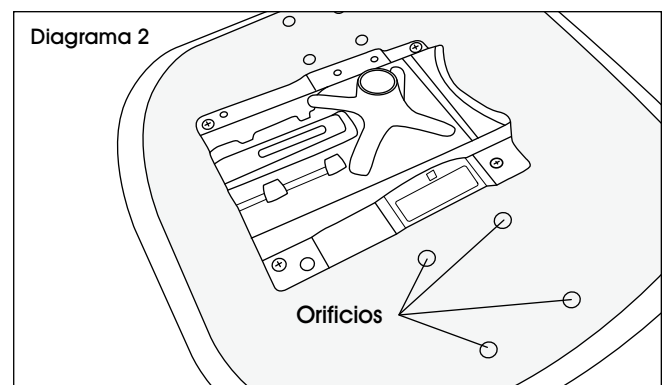

## CONTINUACIÓN DEL ENSAMBLE

3. Alinee el soporte de instalación del descansabrazos con los orificios del asiento y utilice cuatro pernos con rondanas para fijarlo. Inserte el descansabrazos en el soporte de instalación y utilice la perilla del mismo para fijarlo. Repita la operación con el lado opuesto. (Vea Diagrama 3)

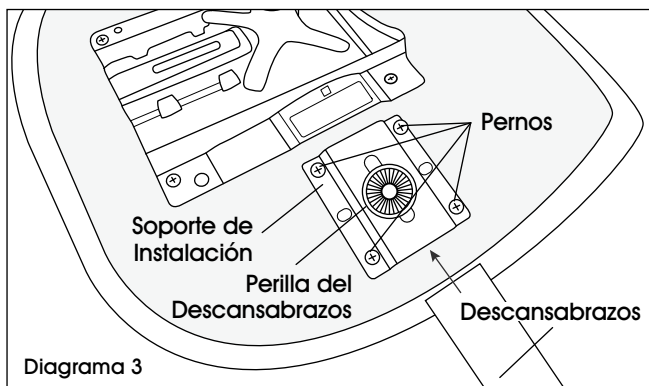

4. Inserte el poste del respaldo en la ranura correspondiente del mecanismo ubicado en la parte inferior del asiento. Apriete la perilla para asegurarlo. (Vea Diagrama 4)

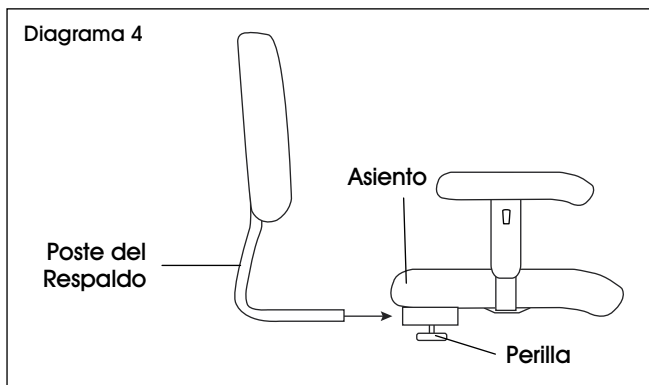

5. Inserte el reposapiés en el pistón de gas y apriete la perilla para asegurarlo. (Vea Diagrama 5)

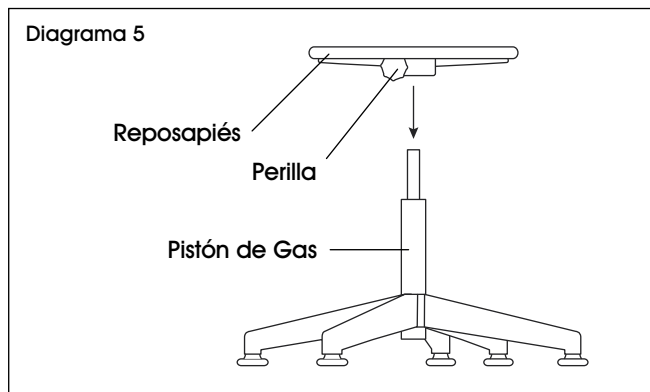

6. Baje lentamente el ensamblaje de la silla sobre el pistón de gas. Presione el asiento para asegurarlo. (Vea Diagrama 6)

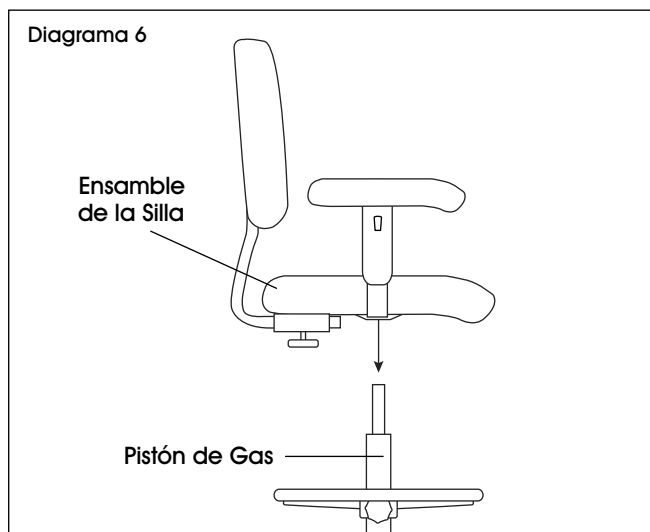

## AJUSTES DE LA SILLA

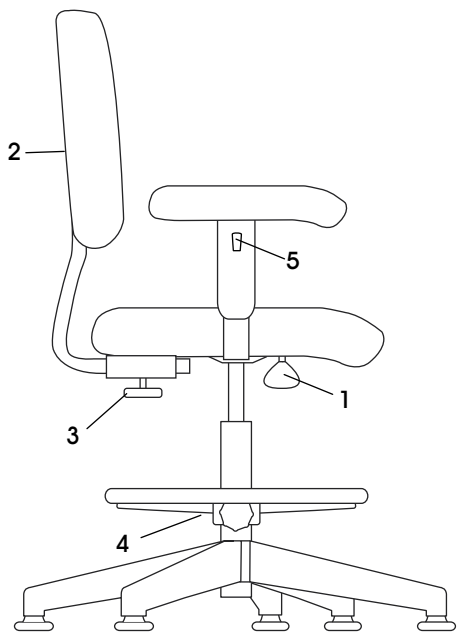

1. Ajuste de la Altura del Asiento – Para subir la altura del asiento, levante la palanca sin o con poco peso en el asiento. Para bajar la altura del asiento, levante la palanca mientras está sentado.
2. Altura del Respaldo – Para subir el respaldo, levante el asiento hasta que haga clic en la altura deseada. Para bajar el respaldo, levántelo a su posición más alta para liberar el mecanismo de trinquete, luego descíndalo al ajuste más bajo.
3. Profundidad del Asiento – Para ajustar la profundidad del asiento, afloje la perilla y deslice el respaldo hacia adentro o afuera. Coloque el respaldo a la profundidad del asiento deseada y apriete la perilla para asegurarlo.
4. Altura del Reposapiés – Para ajustar la altura del reposapiés, afloje la perilla y deslícelo hacia arriba o abajo. Coloque el reposapiés a la altura deseada y apriete la perilla para asegurarlo.
5. Ajuste de la Altura de los Descansabrazos – Para ajustar la altura de los descansabrazos, presione el botón en el lateral de cada uno de ellos y muévalos hacia arriba o abajo.

**ULINE**

800-295-5510  
uline.mx

# ULINE H-6991

## TABOURET DE TRAVAIL DE LUXE EN VINYLE AVEC ACCOUDOIRS AJUSTABLES

1-800-295-5510  
uline.ca

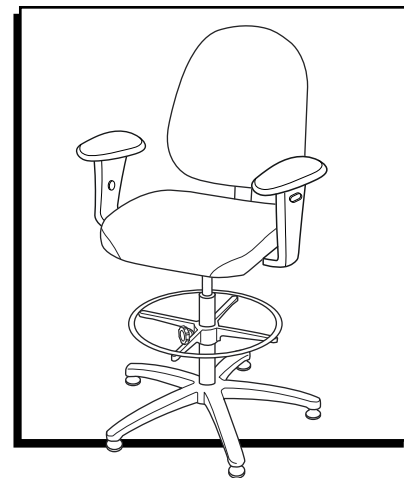

### OUTIL REQUIS

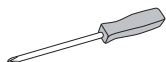

Tournevis cruciforme

### PIÈCES

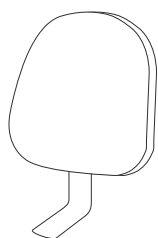

Dossier avec montant x 1



Siège x 1

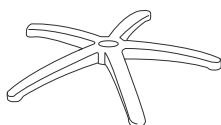

Base à 5 branches x 1



Patin x 5

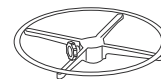

Repose-pied x 1



Vérin pneumatique x 1



Support de fixation pour accoudoir x 2

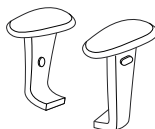

Accoudoir x 2



Boulon x 8



Rondelle x 8



Molette pour accoudoir x 2

### ASSEMBLAGE

1. Insérez les patins dans les pieds de la base à cinq branches. Tournez la base à l'endroit. Insérez le vérin pneumatique dans le centre de la base. (Voir Figure 1)
2. Passez la main sur la housse en tissu pour repérer les trous filetés situés sous le siège. Utilisez le tournevis pour percer délicatement le tissu à chaque trou. (Voir Figure 2)

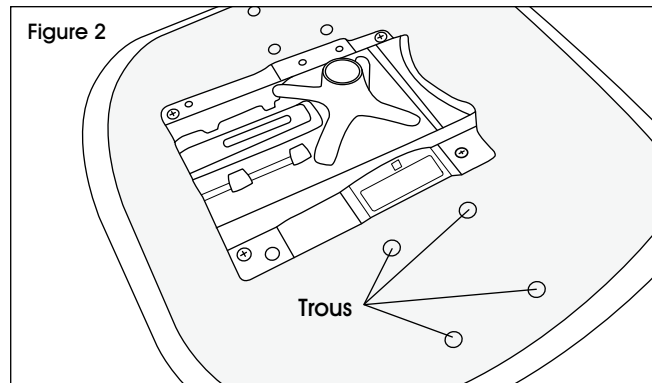
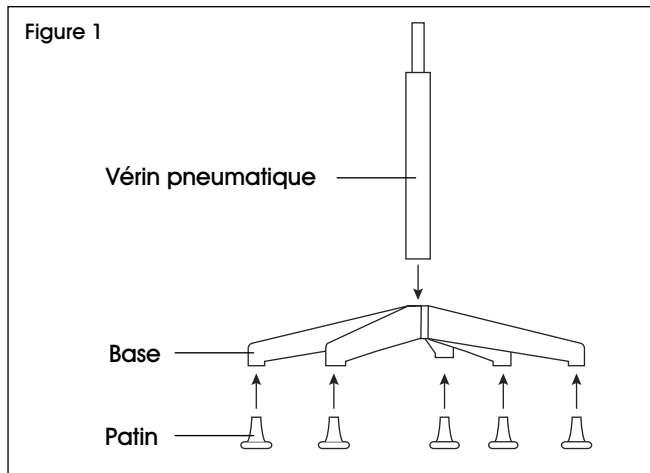

## ASSEMBLAGE SUITE

- Alignez le support de fixation pour accoudoir sur les trous du siège et utilisez quatre boulons avec des rondelles pour le fixer. Insérez un accoudoir dans le support de fixation et utilisez la molette d'accoudoir pour le fixer. Répétez la procédure de l'autre côté. (Voir Figure 3)

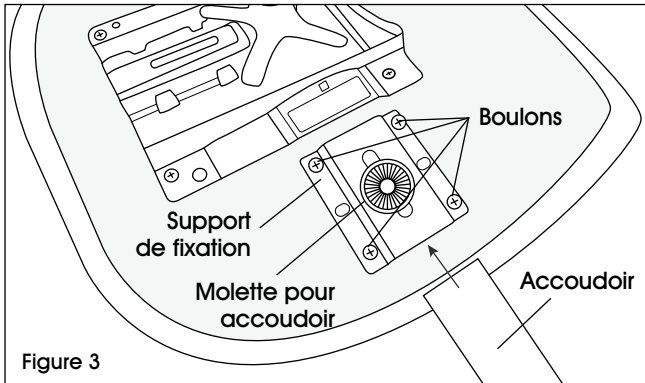

- Insérez le montant du dossier dans la fente correspondante du mécanisme situé sous le siège. Serrez la molette pour le fixer. (Voir Figure 4)

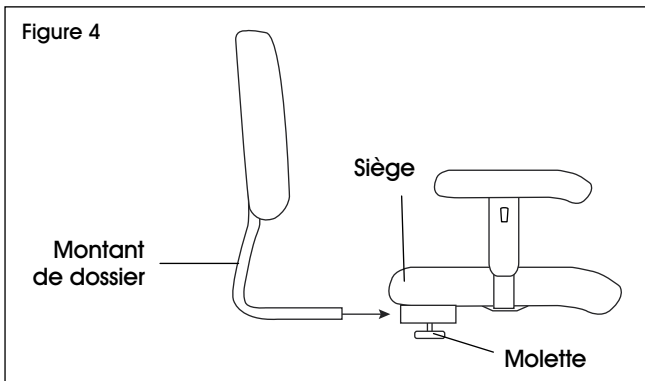

- Faites glisser le repose-pied sur le vérin pneumatique et serrez la molette pour le fixer. (Voir Figure 5)

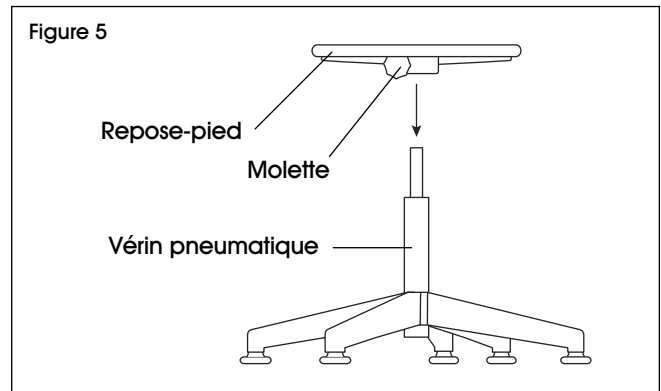

- Abaissez lentement le tabouret sur le vérin pneumatique. Appuyez sur le siège pour le fixer. (Voir Figure 6)

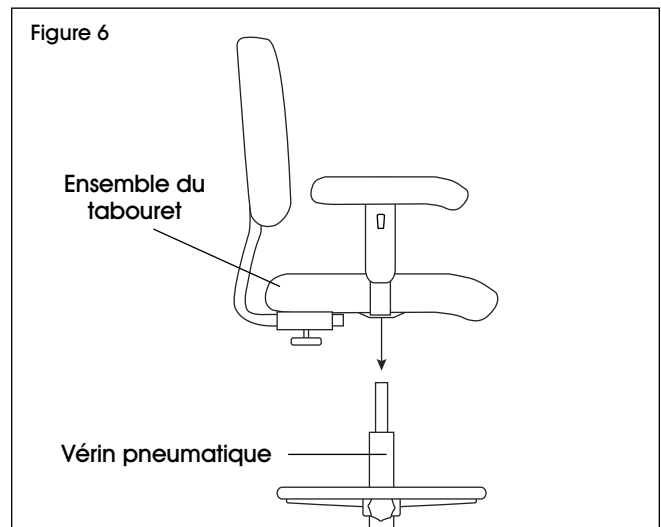



## RÉGLAGES DU TABOURET

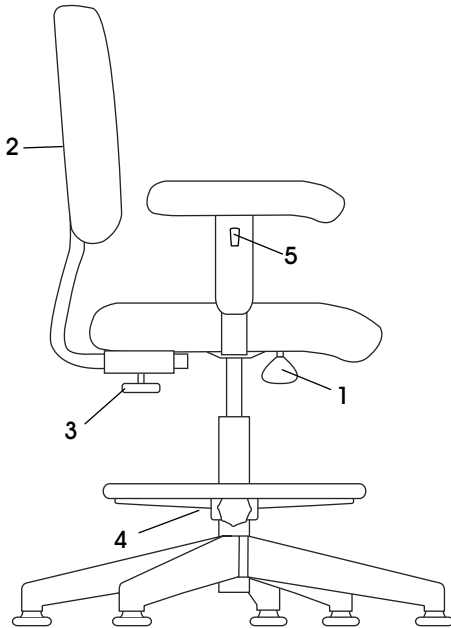

1. Réglage de la hauteur du siège – Pour élever le siège, soulevez le levier avec peu ou sans poids sur le siège. Pour abaisser le siège, soulevez le levier en position assise.
2. Hauteur du dossier – Pour élever le dossier, soulevez-le jusqu'à ce qu'il s'enclenche à la hauteur voulue. Pour abaisser le dossier, soulevez-le à sa hauteur maximale afin de déclencher le mécanisme à cliquet, puis poussez-le à la hauteur minimale.
3. Profondeur d'assise – Pour régler la profondeur d'assise, desserrez la molette et faites glisser le dossier vers l'intérieur ou l'extérieur. Réglez le dossier à la profondeur d'assise désirée et serrez la molette pour le fixer.
4. Hauteur du repose-pied – Pour ajuster la hauteur du repose-pied, desserrez la molette et faites glisser le repose-pied vers le haut ou le bas. Réglez le repose-pied à la hauteur désirée et serrez la molette pour le fixer.
5. Réglage de la hauteur des accoudoirs – Pour régler les accoudoirs en hauteur, appuyez sur le bouton situé sur le côté de chacun des accoudoirs, puis faites bouger ceux-ci vers le haut ou vers le bas.

**ULINE**

1-800-295-5510  
uline.ca