

ULINE H-7053 CONVERGENCE MESH TASK CHAIR

1-800-295-5510
uline.com

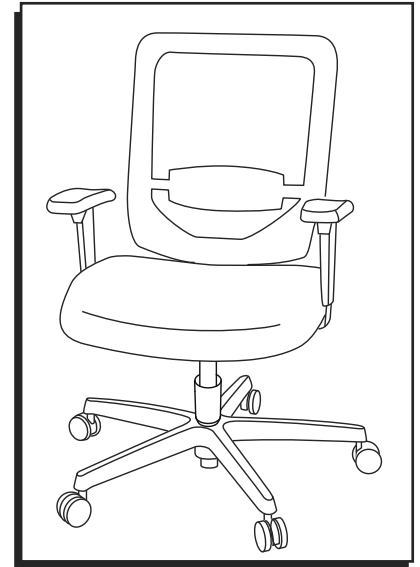

TOOL INCLUDED



Allen Wrench

PARTS

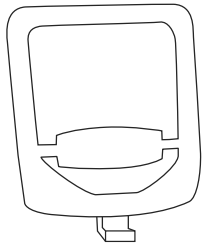

Back Support x 1



Seat Cushion x 1

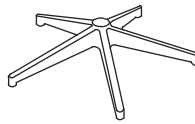

5-Star Base x 1



Caster x 5

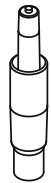

Gas Lift x 1

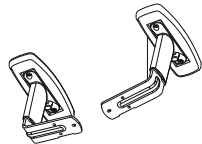

Armrest x 2

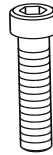

Screw x 3



Washer x 3

ASSEMBLY INSTRUCTIONS

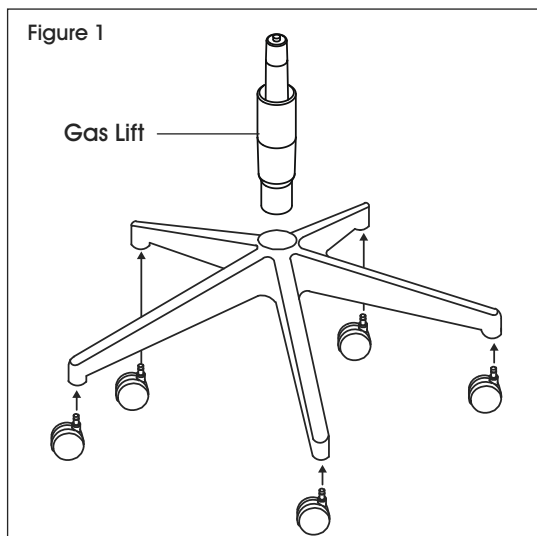

Figure 1

Gas Lift

1. Insert casters into legs of five-star base. Turn base right side up. Insert gas lift into center of base. (See Figure 1)

ASSEMBLY INSTRUCTIONS CONTINUED

Figure 2

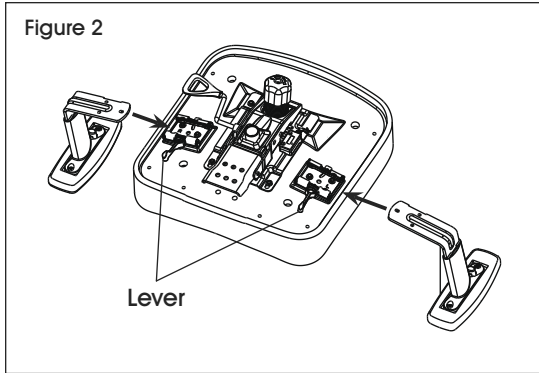

2. Slide armrest into bracket on bottom of seat cushion until it clicks. Push in lever toward armrest to lock. Repeat on opposite side. (See Figure 2)

Figure 3a

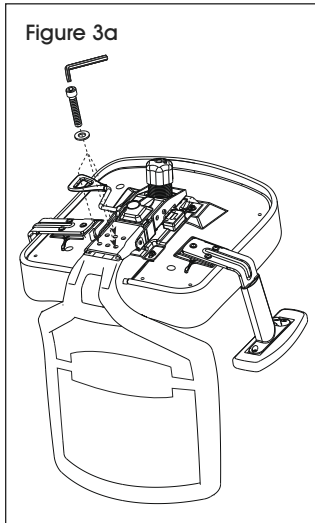
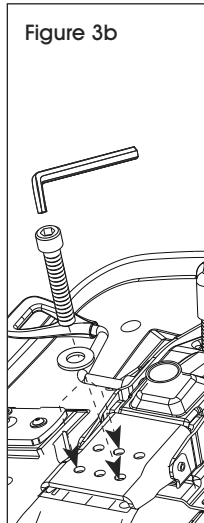

Figure 3b



3. Position back support in slot between bottom of seat cushion and mechanism. Align holes and use three screws with washers to attach back support to mechanism. (See Figures 3a - 3b)

 **NOTE:** Use Allen wrench to tighten all screws.

Figure 4

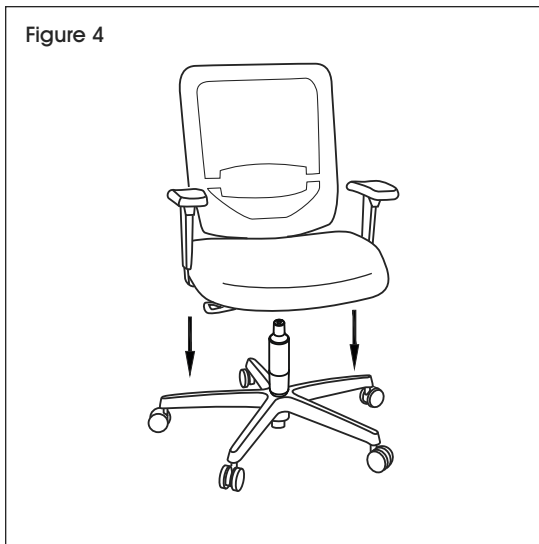

4. Slowly lower assembled chair and insert center of mechanism into gas lift. Press down on seat to secure in place. (See Figure 4)

CHAIR ADJUSTMENTS

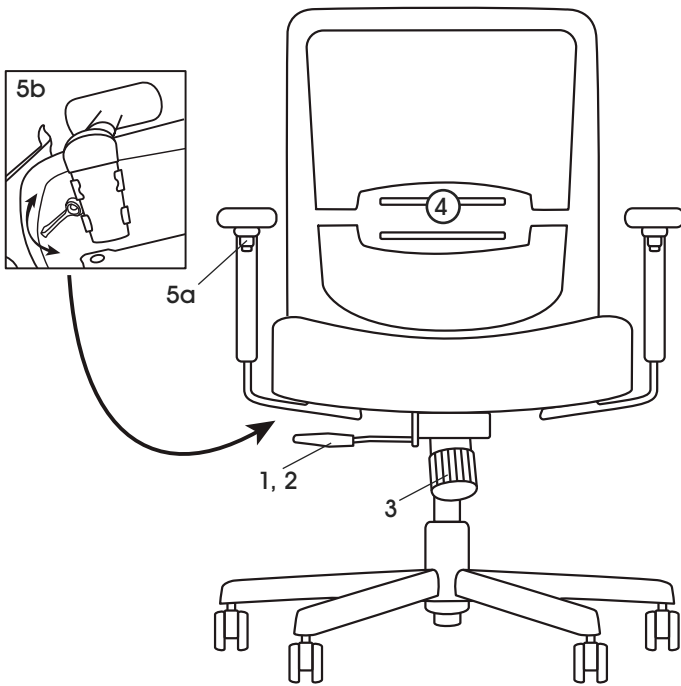

1. **Seat Height Adjustment** – To raise seat height, lift lever up with little to no weight on the seat. To lower seat height, lift lever up while sitting.
2. **Upright Tilt Lock** – To lock chair in an upright position, push the lever in toward the center of the seat. To restore tilt, pull lever out. Chair has standard tilt; the seat and back tilt simultaneously at the same ratio.
3. **Tilt Tension** – To increase tilt tension, turn knob clockwise. To decrease tilt tension, turn knob counterclockwise.
4. **Lumbar Support** – To position higher or lower on the back, slide the lumbar support up or down.
5. **Armrest Adjustment**
 - a. **Height** – To adjust arm height, press the button under armrest pad and move the armrest up or down.
 - b. **Width** – To adjust arm width, pull lever under seat away from armrest and move the armrest in or out. Push lever in toward armrest to lock.

ULINE

1-800-295-5510
uline.com

ULINE H-7053

CONVERGENCE SILLA DE MALLA PARA TRABAJO

800-295-5510

uline.mx

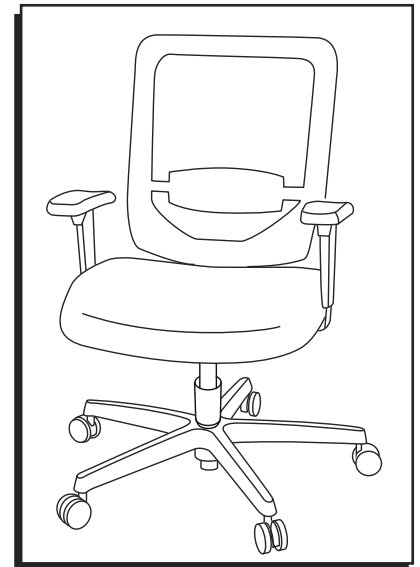

HERRAMIENTA INCLUIDA



Llave Allen

PARTES

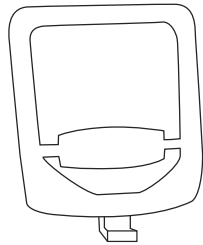

1 Respaldo



1 Asiento

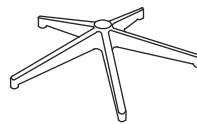

1 Base Estrella

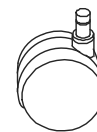

5 Ruedas

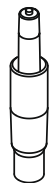

1 Pistón de Gas

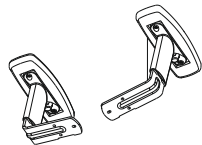

2 Descansabrazos

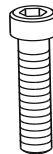

3 Tornillos



3 Rondanas

INSTRUCCIONES DE ENSAMBLE

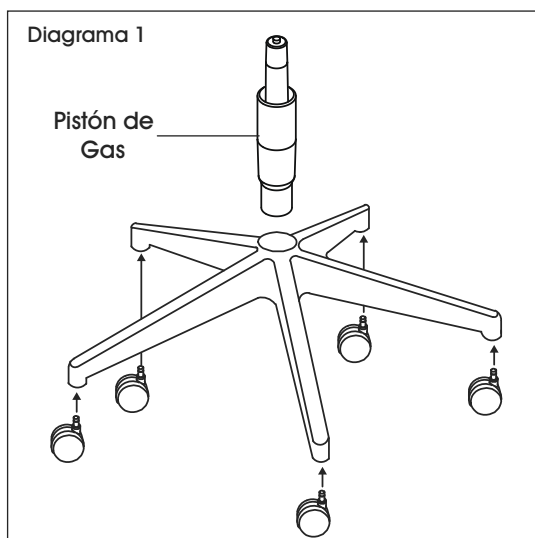

1. Inserte las ruedas en las patas de la base estrella. Enderece la base. Inserte el pistón de gas en el centro de la base. (Vea Diagrama 1)

CONTINUACIÓN DE INSTRUCCIONES DE ENSAMBLE

Diagrama 2

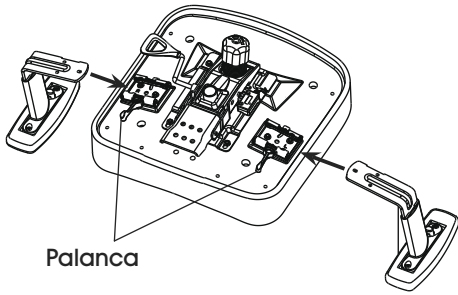

2. Deslice el descansabrazos dentro del soporte en la parte inferior del asiento hasta que haga clic. Empuje la palanca hacia el descansabrazos para bloquearlo. Repita la operación con el lado opuesto. (Vea Diagrama 2)

Diagrama 3a



Diagrama 3b



3. Posicione el respaldo en la ranura que está entre la parte inferior del asiento y el mecanismo. Alinee los orificios y utilice tres tornillos con rondanas para fijar el respaldo al mecanismo. (Vea Diagramas 3a - 3b)

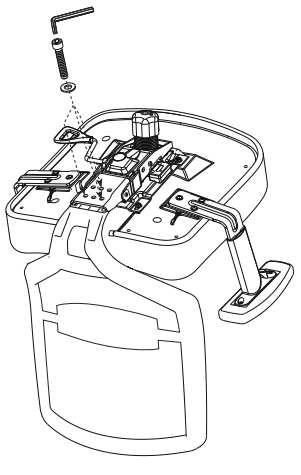
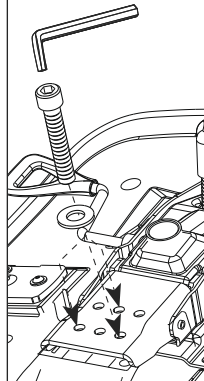

NOTA: Utilice la llave Allen para apretar todos los tornillos.

Diagrama 4

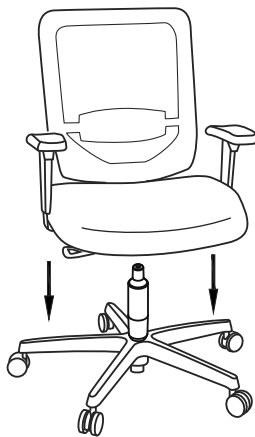

4. Baje lentamente el ensamble de la silla e inserte el centro del mecanismo sobre el pistón de gas. Presione el asiento para asegurarlo en su lugar. (Vea Diagrama 4)

AJUSTES DE LA SILLA

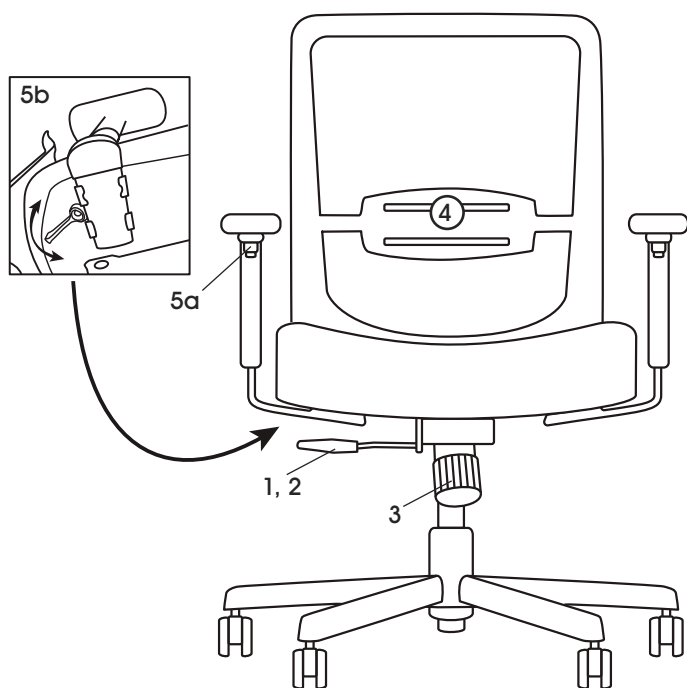

1. Ajuste de la Altura del Asiento – Para aumentar la altura del asiento, levante la palanca con poco peso o sin peso en el asiento. Para bajar la altura del asiento, levante la palanca mientras está sentado.
2. Bloqueo de la Inclinación del Poste – Para bloquear la silla en una posición vertical, empuje la palanca hacia el centro del asiento. Para restaurar la inclinación, jale la palanca. La silla tiene una inclinación estándar, el asiento y el respaldo se inclinan simultáneamente en la misma proporción.
3. Tensión de Inclinación – Para aumentar la tensión de la inclinación, gire la perilla en el sentido de las manecillas del reloj. Para disminuir la tensión de la inclinación, gire la perilla en el sentido contrario de las manecillas del reloj.
4. Soporte Lumbar – Para colocar más arriba o más abajo en la espalda, deslice el soporte lumbar hacia arriba o hacia abajo.
5. Ajuste del Descansabrazos
 - a. Altura – Para ajustar la altura del brazo, presione el botón debajo de la almohadilla del descansabrazos y muévalo hacia arriba o hacia abajo.
 - b. Ancho – Para ajustar el ancho del brazo, empuje la palanca debajo del asiento lejos del descansabrazos y muévalo hacia afuera o hacia adentro. Empuje la palanca hacia adentro y hacia el descansabrazos para bloquearlo.

ULINE

800-295-5510
uline.mx

ULINE H-7053

CONVERGENCE – CHAISE DE TRAVAIL EN MAILLE

1-800-295-5510
uline.ca

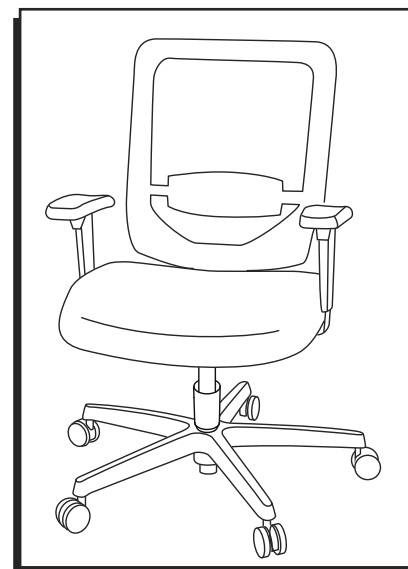

OUTIL INCLUS



Clé Allen

PIÈCES

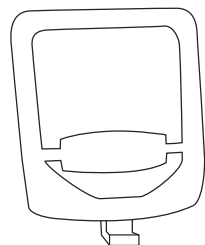

Dossier x 1



Siège x 1

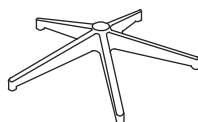

Base à 5 branches x 1

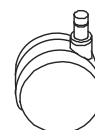

Roulette x 5



Vérin
pneumatique x 1

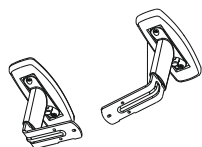

Accoudoir x 2

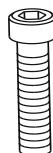

Vis x 3



Petite rondelle x 3

INSTRUCTIONS D'ASSEMBLAGE

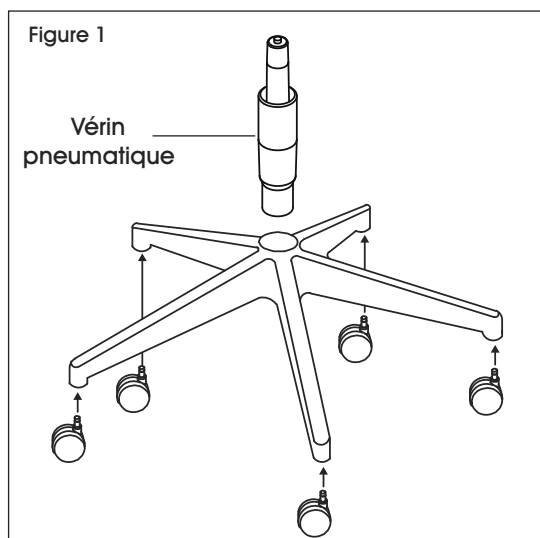

1. Insérez les roulettes dans les pieds de la base à cinq branches. Placez la base à l'endroit. Insérez le vérin pneumatique dans le centre de la base. (Voir Figure 1)

INSTRUCTIONS D'ASSEMBLAGE SUITE

Figure 2

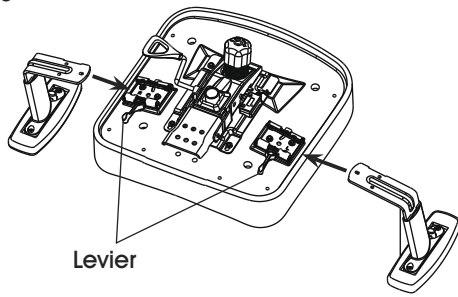

2. Faites glisser l'accoudoir dans le support situé sous le siège jusqu'à ce qu'il s'enclenche. Poussez le levier vers l'accoudoir pour le verrouiller. Répétez l'opération de l'autre côté. (Voir Figure 2)

Figure 3a

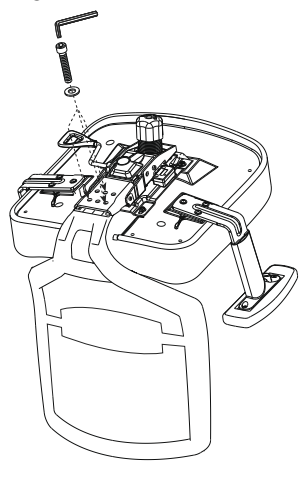
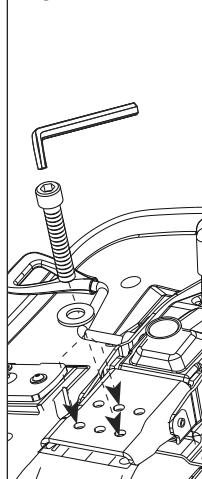

Figure 3b



3. Insérez le dossier dans la fente située entre le dessous du siège et le mécanisme. Alignez les trous et insérez trois vis avec rondelles pour fixer le dossier au mécanisme. (Voir Figures 3a et 3b)

 **REMARQUE :** Utilisez la clé Allen pour serrer toutes les vis.

Figure 4

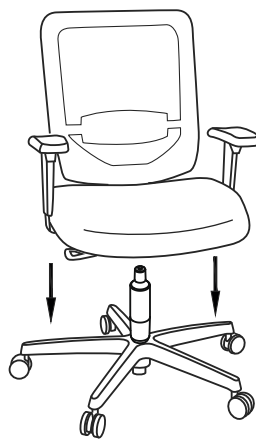

4. Abaissez lentement la chaise assemblée et insérez le centre du mécanisme dans le vérin pneumatique. Appuyez sur le siège pour le fixer en place. (Voir Figure 4)

RÉGLAGES DE LA CHAISE

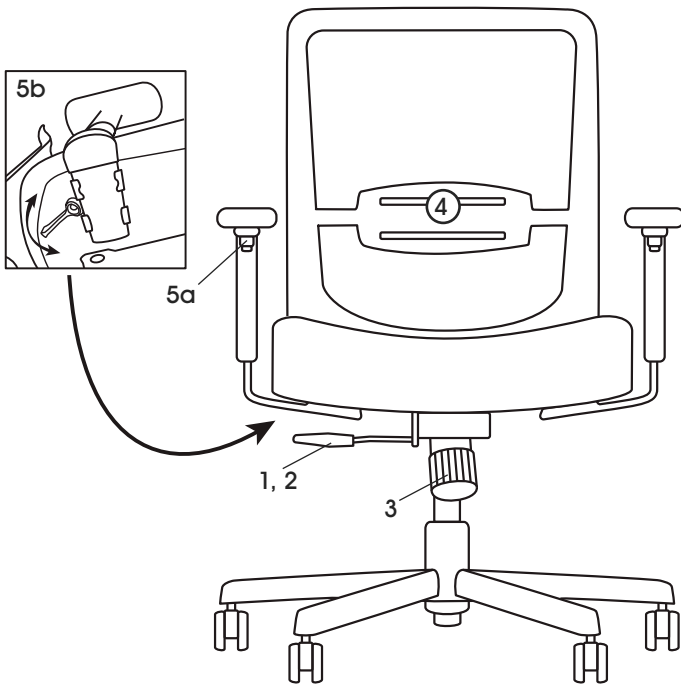

1. Réglage de la hauteur du siège – Pour élever la hauteur du siège, soulevez le levier avec peu ou sans poids sur le siège. Pour abaisser la hauteur du siège, soulevez le levier en position assise.
2. Inclinaison avec blocage en position verticale – Pour bloquer la chaise en position verticale, poussez le levier vers le centre du siège. Pour rétablir l'inclinaison, tirez le levier vers l'extérieur. La chaise comporte une inclinaison standard; le siège et le dossier s'inclinent au même degré simultanément.
3. Tension d'inclinaison – Pour augmenter la tension d'inclinaison, tournez la molette dans le sens horaire. Pour diminuer la tension d'inclinaison, tournez la molette dans le sens antihoraire.
4. Soutien lombaire – Pour positionner le support lombaire plus haut ou plus bas sur le dos, glissez-le vers le haut ou vers le bas.
5. Réglage des accoudoirs
 - a. Hauteur – Pour régler la hauteur des accoudoirs, appuyez sur le bouton situé sous le rembourrage, puis déplacez l'accoudoir vers le haut ou vers le bas.
 - b. Écartement – Pour régler l'écartement des accoudoirs, tirez le levier sous le siège en l'éloignant de l'accoudoir, puis déplacez l'accoudoir vers l'intérieur ou l'extérieur. Poussez le levier vers l'accoudoir pour le verrouiller.

ULINE

1-800-295-5510
uline.ca