

# ULINE H-7058

## CLASSIC CONFERENCE TABLE

1-800-295-5510  
uline.com

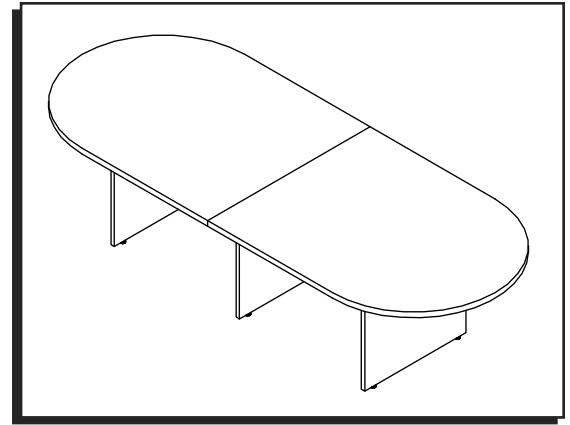

### TOOLS NEEDED

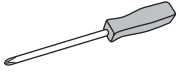

Phillips  
Screwdriver



Drill  
(Optional)



Three Person Assembly  
Required

### PARTS

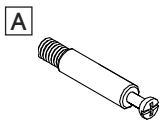

Camlock Pin x 18

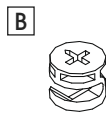

Camlock x 18

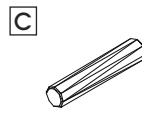

Dowel x 16

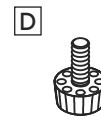

Floor Glide x 6

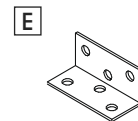

L-Bracket x 4

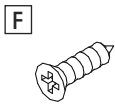

Screw x 27  
M4 x 16 mm

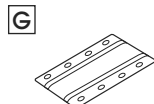

Flat Bracket x 2

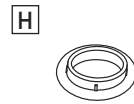

Deep Camlock  
Cap x 5

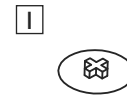

Camlock Cap x 13

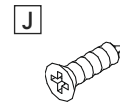

Screw x 18  
M5 x 19 mm

### ASSEMBLY



**NOTE:** Assemble on a smooth, non-marring surface to avoid scratching the table.

- Check that all parts are included.



**IMPORTANT:** The arrow on the camlock (B) must point toward the camlock pin (A) for proper alignment. Turn camlock (B) clockwise until it locks with pin (A).

**IMPORTANT:** Function of Cam



1/4 Right Turn  
for Locking

Ensure the arrow is pointing toward edge of panel before inserting into the panel's hole.

1. Insert two camlocks (B) into holes on modesty panel (3). Insert two camlock pins (A) and two dowels (C) in outside leg (1). Fit outside leg (1) and modesty panel (3) together and turn each camlock (B) clockwise until it locks. Cover each camlock (B) with a camlock cap (I). (See Figure 1)

2. Repeat to attach the second outside leg and modesty panel together.
3. Use four camlock pins (A), four camlocks (B) and four dowels (C) to attach center leg (2) between the two pieces assembled in Steps 1 and 2. (See Figure 1)

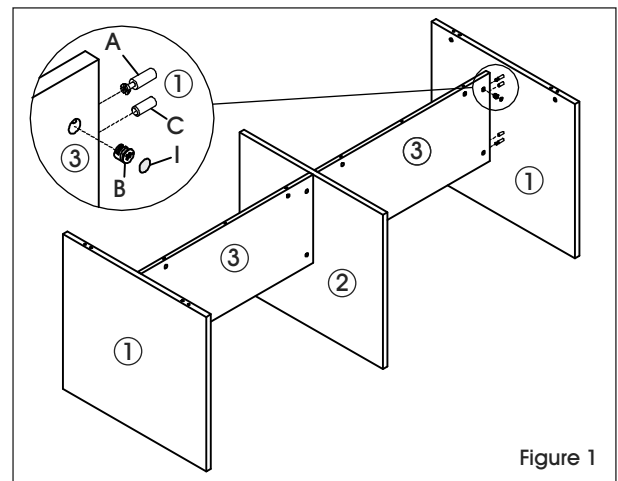
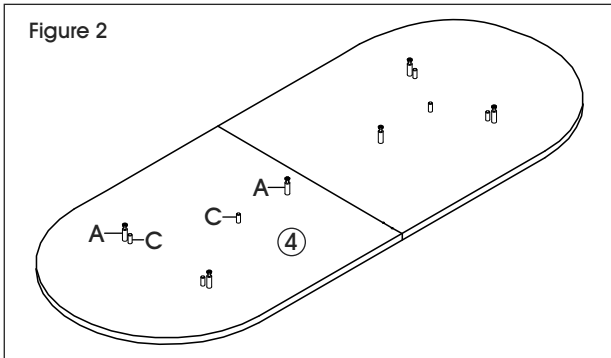

Figure 1

## ASSEMBLY CONTINUED

- Place tabletop panels (4) upside down on a smooth, non-marring surface and push flat ends together. Insert eight camlock pins (A) and six dowels (C). (See Figure 2)



- Insert eight camlocks (B) into corresponding holes on modesty panels (3). With three people, place the assembled base on the tabletop panels (4). Turn each camlock (B) clockwise until it locks. Cover each camlock (B) with a deep camlock cap (H). (See Figure 3)

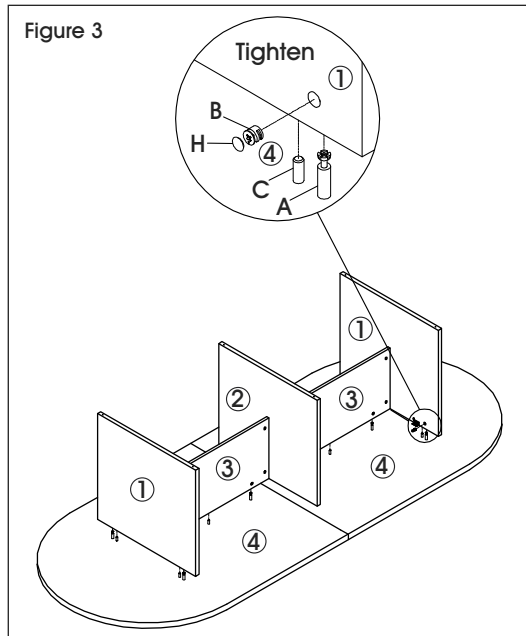

- Attach an L-Bracket (E) to each outside leg (1) and secure to the corresponding tabletop panel (4) using four M4 x 16 mm screws (F) per bracket. Tighten screws with Phillips screwdriver. (See Figure 4)
- Attach an L-Bracket (E) to each side of the center leg (2) and secure to the corresponding tabletop panel (4) using four M4 x 16 mm screws (F) per bracket. Tighten screws with Phillips screwdriver. (See Figure 4)

 **NOTE:** Ensure at least one L-Bracket connects each outside leg (1) to the corresponding tabletop panel (4) and the center leg (2) is connected to both tabletop panels (4). (See Figure 4)

 **NOTE:** L-Bracket holes can be started with drill (optional).

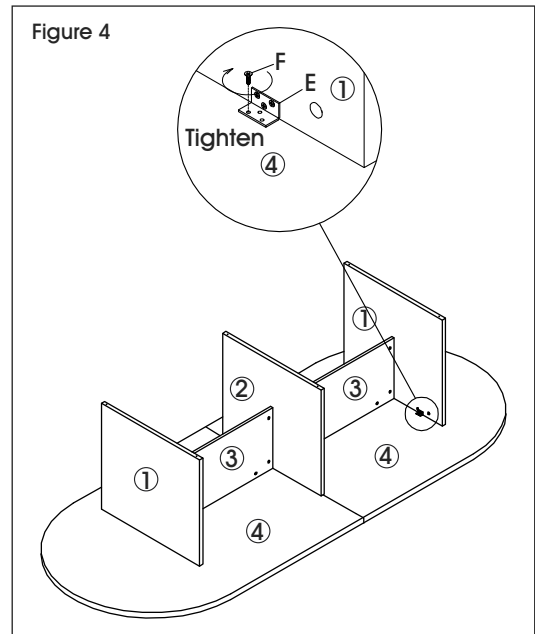

## ASSEMBLY CONTINUED

- Fasten tabletop panels (4) together by securing flat bracket (G) with eight M5 x 19 mm screws (J). Tighten screws with Phillips screwdriver. Repeat on the other side of the table. (See Figure 5)

 **NOTE:** Flat bracket holes can be started with drill (optional).

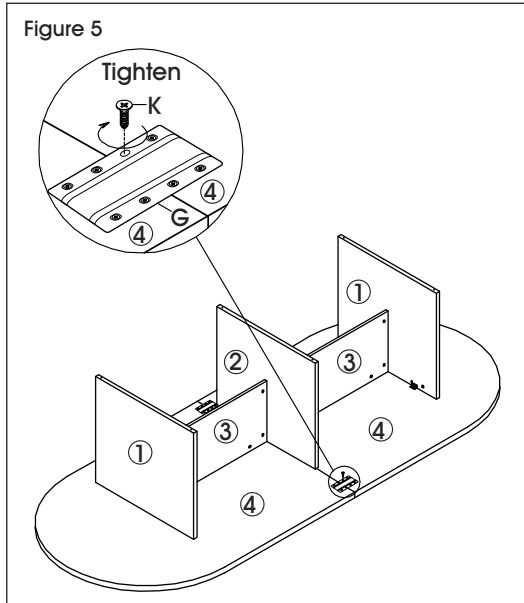

- Mount floor glides (D) on outside legs (1) and center leg (2). Floor glides (D) can be adjusted to compensate for uneven floors. (See Figure 6)

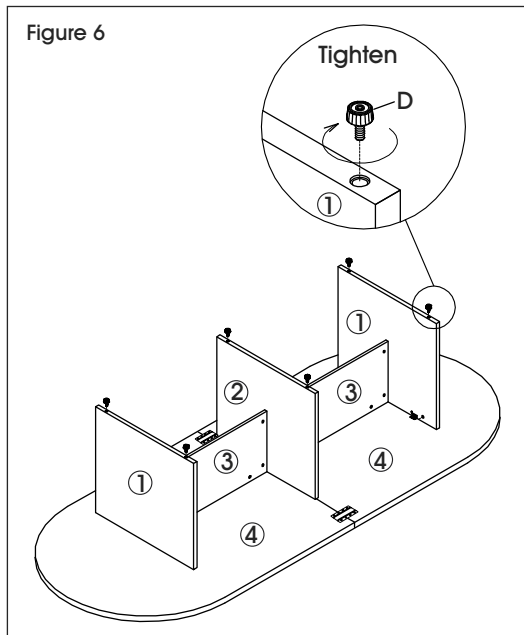

- With three people, turn the table over and set it upright. (See Figure 7)
- While positioning or moving the table, at least one person should be in the middle to support the center of the table.

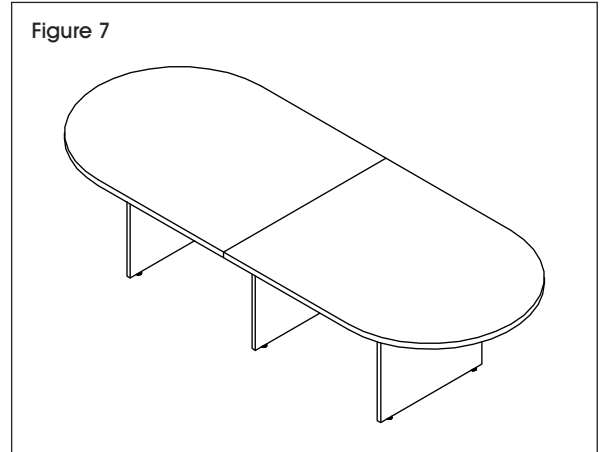

**ULINE H-7058**

# MESA DE CONFERENCIA CLÁSICA

800-295-5510  
uline.mx

## HERRAMIENTAS NECESARIAS

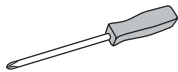

Desarmador de Cruz



Taladro (Opcional)



Se Requiere Armar Entre Tres Personas

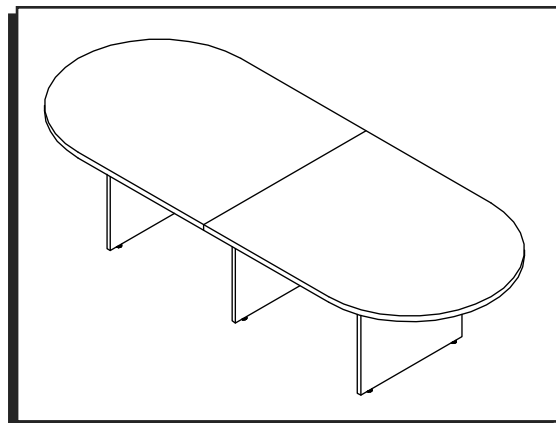

## PARTES

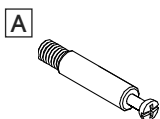

18 Pasadores de Tuerca Minifix

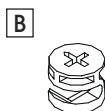

18 Tuercas Minifix

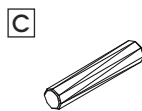

16 Taquetes



6 Tapas para Piso

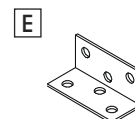

4 Soportes en L

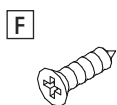

27 Tornillos M4 x 16 mm

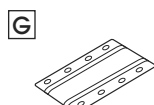

2 Soportes Planos

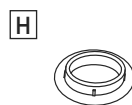

5 Tapas Profundas para Tuercas Minifix

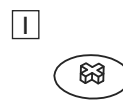

13 Tapas para Tuercas Minifix

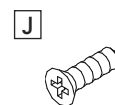

18 Tornillos M5 x 19 mm

## ENSAMBLE



**NOTA:** Ensámblela sobre una superficie lisa que no deje marcas para evitar rayar la mesa.

- Verifique que todas las partes estén incluidas.



**IMPORTANTE:** La flecha en la tuerca minifix (B) debe apuntar hacia el pasador de la tuerca minifix (A) para una correcta alineación. Gire la tuerca minifix (B) en sentido de las manecillas del reloj hasta que se bloquee con el pasador (A).

**IMPORTANTE:** Función de la Tuerca Minifix



Gire 1/4 a la Derecha para Bloquearlo

Asegúrese de que la flecha apunte al borde del panel antes de insertarla en el orificio del panel.

1. Inserte dos tuercas minifix (B) en los orificios en el recato (3). Inserte dos pasadores para tuercas minifix (A) y dos taquetes (C) en la pata exterior (1). Junte la pata exterior (1) y el recato (3) y gire cada tuerca minifix (B) en sentido de las manecillas del reloj hasta que se bloqueen. Cubra cada tuerca minifix (B) con una tapa (I). (Vea Diagrama 1)

2. Repita para fijar la segunda pata exterior y el recato juntos.
3. Use cuatro pasadores de tuerca minifix (A), cuatro tuercas minifix (B) y cuatro taquetes (C) para fijar la pata central (2) entre las dos piezas ensambladas en los Pasos 1 y 2. (Vea Diagrama 1)



Diagrama 1

## CONTINUACIÓN DEL ENSAMBLE

4. Coloque los paneles de la cubierta (4) boca abajo sobre una superficie lisa, que no deje marcas, para evitar rayones. Inserte ocho pasadores para tuercas minifix (A) y seis taquetes (C). (Vea Diagrama 2)

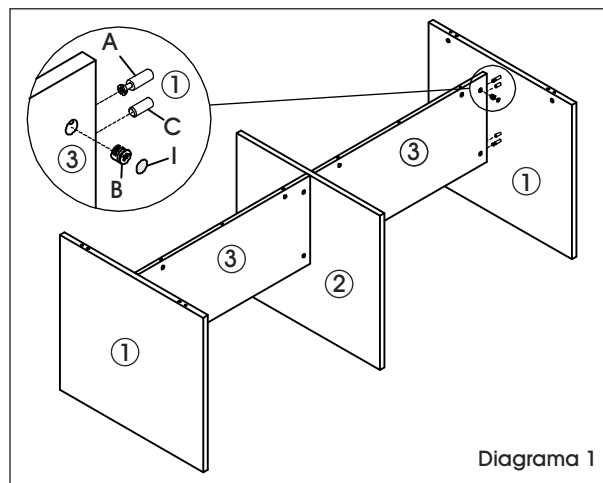
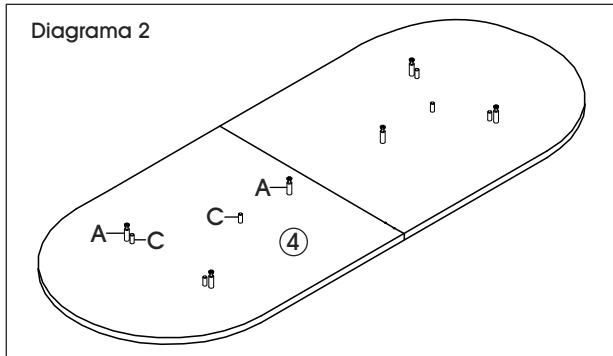

5. Inserte ocho tuercas minifix (B) en los orificios correspondientes en el recato (3). Entre tres personas, coloquen la base ensamblada sobre los paneles de la cubierta de la mesa (4). Gire cada tuerca minifix (B) en sentido de las manecillas de reloj hasta que se bloqueen. Cubra cada tuerca minifix (B) con una tapa profunda (H). (Vea Diagrama 3)

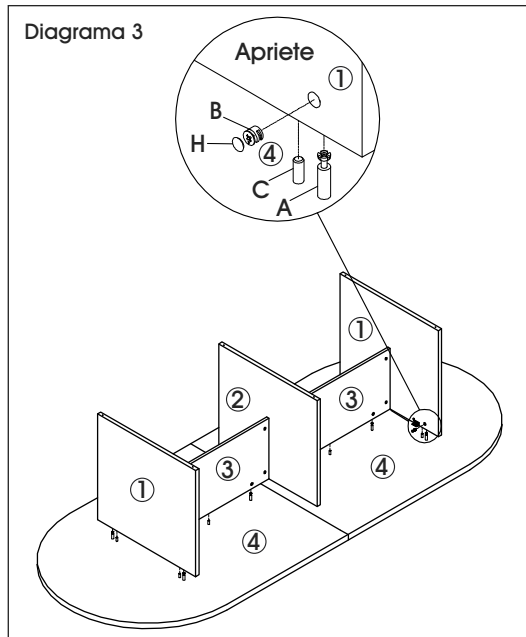

6. Fije un Soporte en L (E) a cada pata exterior (1) y asegúrelo a la cubierta de la mesa correspondiente (4) usando cuatro tornillos M4 x 16 mm (F) por soporte. Apriete los tornillos con el desarmador de cruz. (Vea Diagrama 4)
7. Fije un Soporte en L (E) a cada lado de la pata central (2) y asegúrelo al panel de la cubierta de la mesa correspondiente (4) usando cuatro tornillos M4 de 16 mm (F) por soporte. Apriete los tornillos con el desarmador de cruz. (Vea Diagrama 4)

 **NOTA:** Asegúrese de que al menos un Soporte en L conecte la parte exterior de la pata (1) con el panel de cubierta de la mesa correspondiente y que la pata central (2) esté conectada a ambos paneles de la cubierta de mesa (4). (Vea Diagrama 4)

 **NOTA:** Los orificios del Soporte en L se pueden hacer con taladro (opcional).

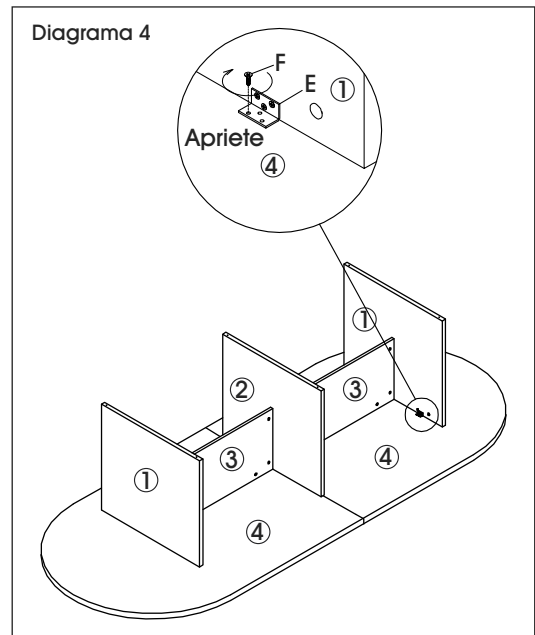

## CONTINUACIÓN DEL ENSAMBLE

8. Apriete juntos los paneles de la cubierta de la mesa (4) asegurando un soporte plano (G) con ocho tornillos M5 x 19 mm (J). Apriete los tornillos con el desarmador de cruz. Repita en el otro lado de la mesa. (Vea Diagrama 5)

 **NOTA:** Los orificios del soporte en L se pueden hacer con taladro (opcional).

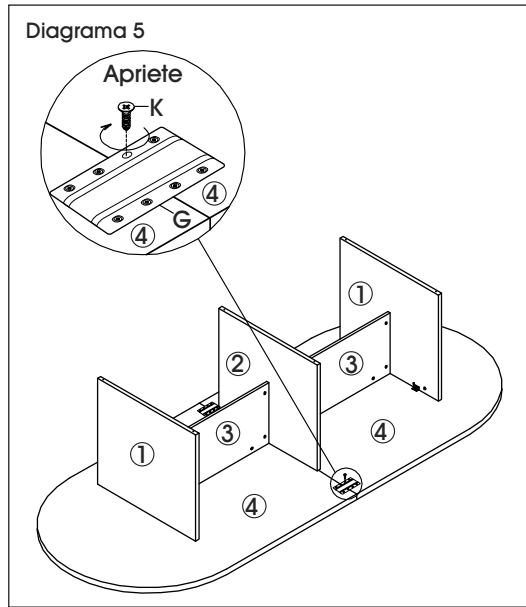

9. Instale las tapas para piso (D) en la pata exterior (1) y la pata central (2). Las tapas para piso (D) se pueden ajustar para compensar los pisos irregulares. (Vea Diagrama 6)

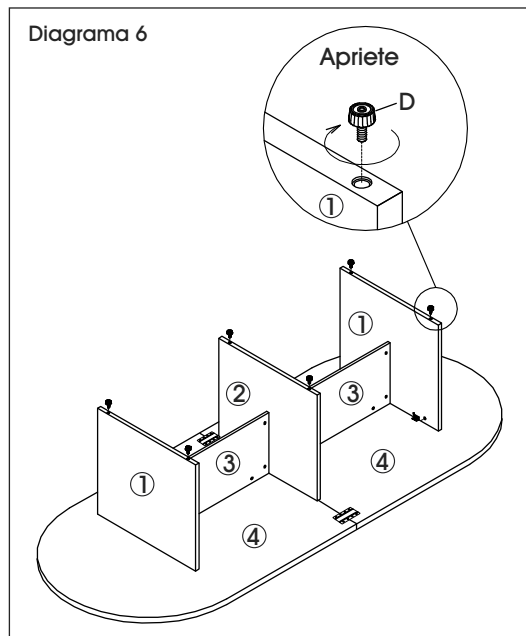

10. Entre tres personas, volteen la mesa y enderécenla. (Vea Diagrama 7)
11. Mientras acomodan o mueven la mesa, al menos una persona debe estar en medio para sostener el centro de la mesa.

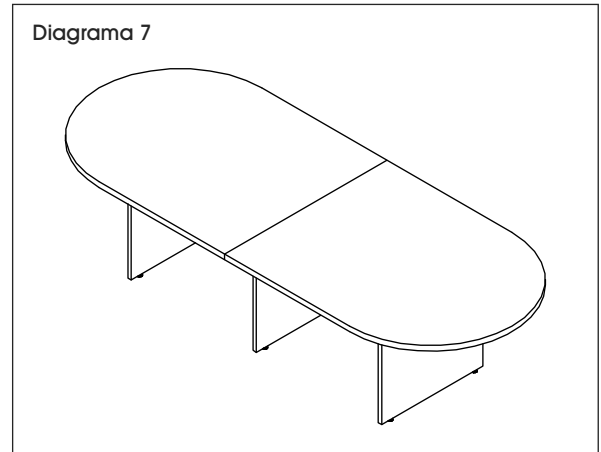

**ULINE H-7058**

# TABLE DE CONFÉRENCE CLASSIQUE

1-800-295-5510

uline.ca

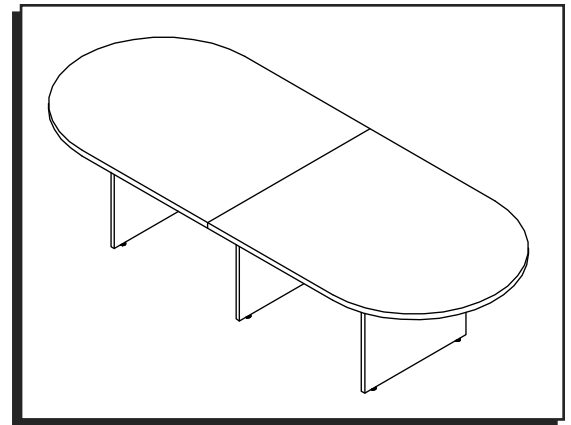

## OUTILS REQUIS

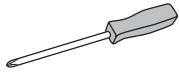

Tournevis  
cruciforme



Perceuse  
(optionnel)



Montage à trois  
personnes requis

## PIÈCES

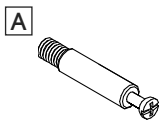

**A**  
Goujon  
d'excentrique x 18

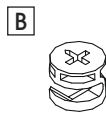

**B**  
Excentrique x 18

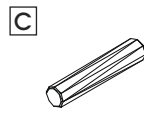

**C**  
Cheville x 16

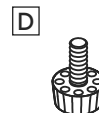

**D**  
Patin de plancher x 6

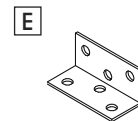

**E**  
Support en L x 4

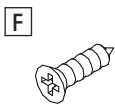

**F**  
Vis M4 x 16 mm x 27

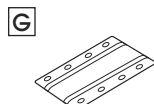

**G**  
Support plat x 2

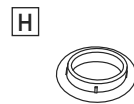

**H**  
Cache profond pour  
excentrique x 5

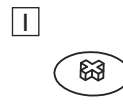

**I**  
Cache pour  
excentrique x 13

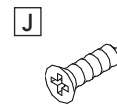

**J**  
Vis M5 x 19 mm x 18

## MONTAGE



**REMARQUE :** Montez la table sur une surface lisse et non marquante afin d'éviter les rayures.

- Vérifiez que toutes les pièces sont incluses.



**IMPORTANT :** Pour un bon alignement, la flèche de l'excentrique (B) doit être orientée vers l'axe du goujon d'excentrique (A). Tournez l'excentrique (B) dans le sens horaire jusqu'à ce qu'il se verrouille avec le goujon (A).

**IMPORTANT :** Fonctionnement de l'excentrique



1/4 de tour vers la  
droite pour verrouiller

Assurez-vous d'abord que la flèche pointe vers le bord du panneau avant de l'insérer dans le trou du panneau.

1. Insérez deux excentriques (B) dans les trous du panneau cache-jambes (3). Insérez deux goujons d'excentrique (A) et deux chevilles (C) dans le pied extérieur (1). Assemblez le pied extérieur (1) et le panneau cache-jambes (3) et tournez chaque excentrique (B) dans le sens horaire jusqu'à ce qu'il se verrouille. Couvrez chaque excentrique (B) avec un cache pour excentrique (I). (Voir Figure 1)

2. Répétez l'opération pour fixer le deuxième pied extérieur au panneau cache-jambes.
3. Utilisez quatre goujons d'excentrique (A), quatre excentriques (B) et quatre chevilles (C) pour fixer le pied central (2) entre les deux éléments assemblés aux étapes 1 et 2. (Voir Figure 1)

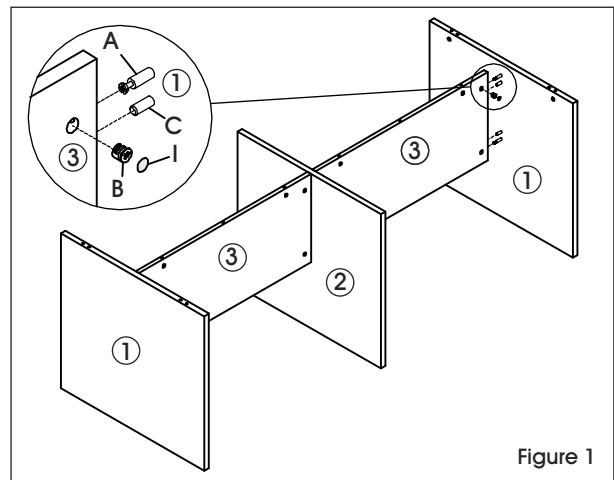
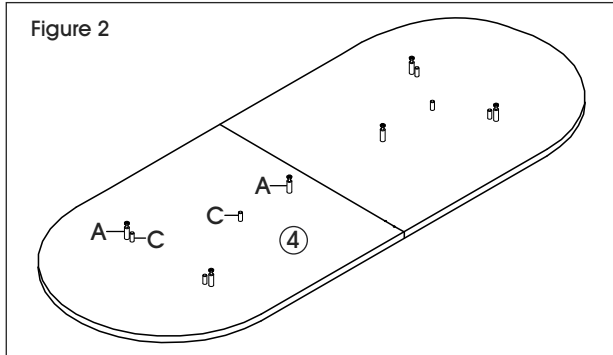

Figure 1

## MONTAGE SUITE

4. Placez les panneaux de la surface de table (4) à l'envers sur une surface lisse non marquante et joignez les deux côtés plats ensemble. Insérez huit goujons d'excentrique (A) et six chevilles (C). (Voir Figure 2)



5. Insérez huit excentriques (B) dans les trous correspondants des panneaux cache-jambes (3). Placez à trois la base assemblée sur les panneaux de la surface de table (4). Tournez chaque excentrique (B) dans le sens horaire jusqu'à ce qu'il se verrouille. Couvrez chaque excentrique (B) avec un cache profond pour excentrique (H). (Voir Figure 3)

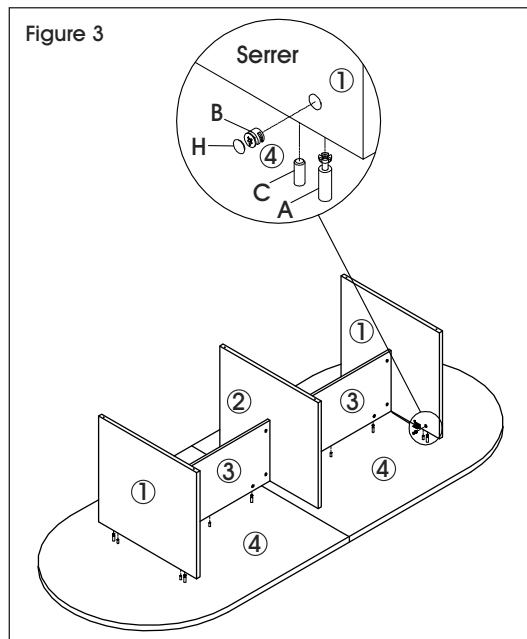

6. Fixez un support en L (E) sur chaque pied extérieur (1) et fixez-le au panneau de la surface de table correspondant (4) avec quatre vis M4 x 16 mm (F) par support. Serrez les vis avec le tournevis cruciforme. (Voir Figure 4)
7. Fixez un support en L (E) de chaque côté du pied central (2) et fixez-le au panneau de la surface de table correspondant (4) avec quatre vis M4 x 16 mm (F) par support. Serrez les vis avec le tournevis cruciforme. (Voir Figure 4)

 **REMARQUE :** Veillez à utiliser au moins un support en L sur chacun des pieds extérieurs (1) pour les fixer au panneau de la surface de table correspondant (4). Assurez-vous également que le pied central (2) est fixé aux deux panneaux de la surface de table (4). (Voir Figure 4)

 **REMARQUE :** Les trous des supports en L peuvent être prépercés avec la perceuse (optionnel).

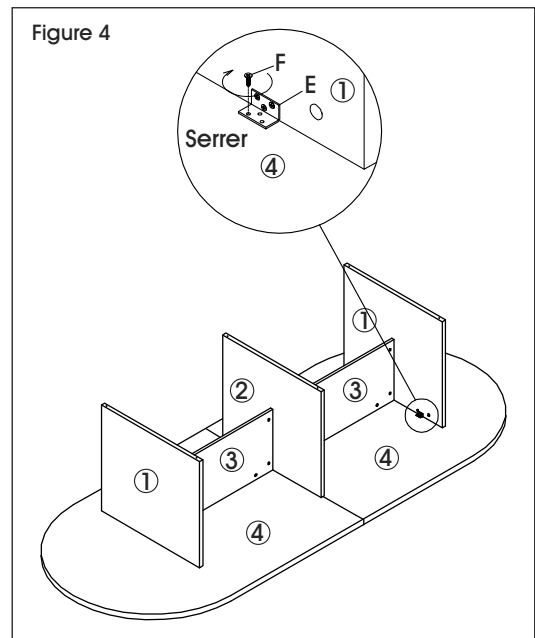



## MONTAGE SUITE

8. Connectez les panneaux de la surface de table (4) ensemble à l'aide du support plat (G) que vous fixerez au moyen de huit vis M5 x 19 mm (J). Serrez les vis avec le tournevis cruciforme. Répétez l'opération de l'autre côté. (Voir Figure 5)



**REMARQUE :** Les trous des supports en L peuvent être préperçés avec la perceuse (optionnel).

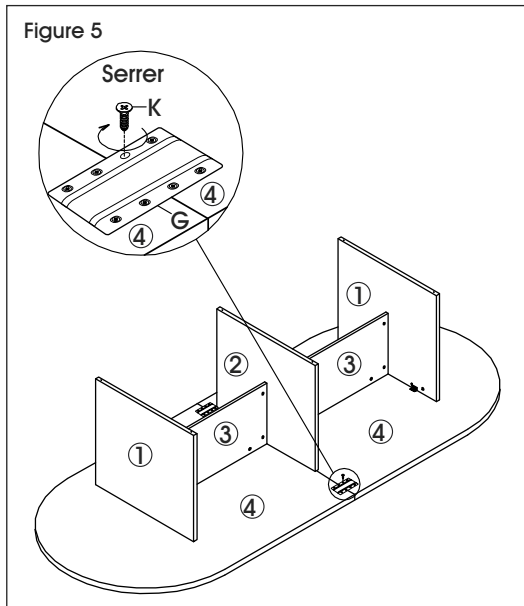

9. Insérez les patins (D) dans les pieds extérieurs (1) et le pied central (2). Les patins de plancher (D) peuvent être réglés pour compenser les inégalités du plancher. (Voir Figure 6)

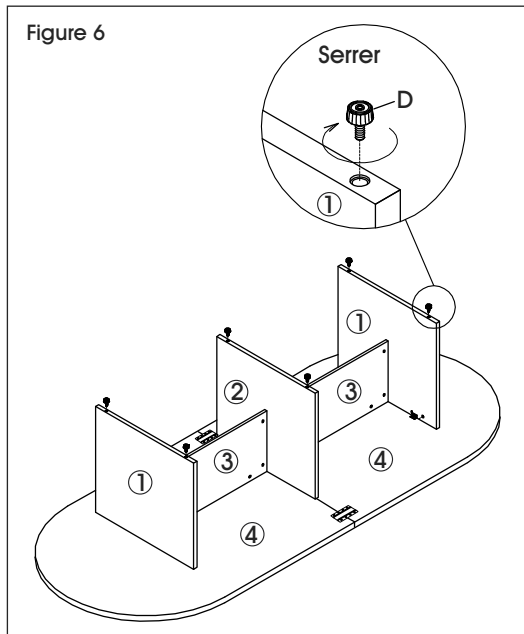

10. Retournez la table à trois et mettez-la à l'endroit. (Voir Figure 7)
11. Lorsque vous positionnez ou déplacez la table, faites en sorte qu'au moins une personne se trouve au milieu pour soutenir le centre de la table.

