

ULINE H-7060 FABRIC BAR HEIGHT CHAIR

1-800-295-5510
uline.com

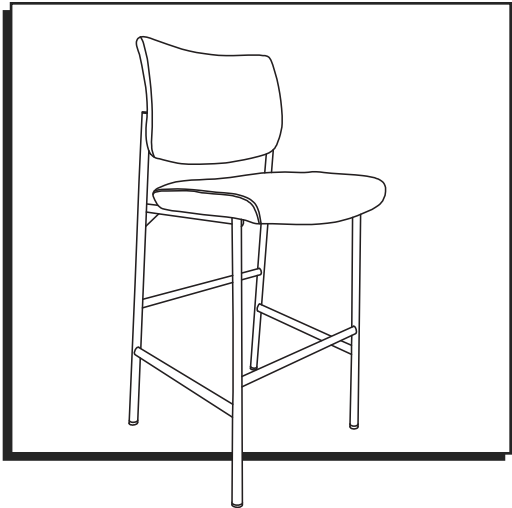

TOOL NEEDED



Allen Wrench
(Included)

PARTS



Seat Cushion x 1

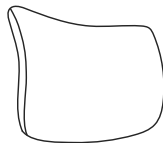

Back Cushion x 1

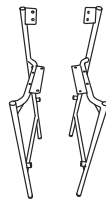

Side Frame x 2

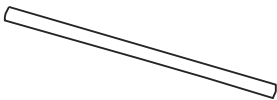

Middle Crossbar x 2

Hardware Kit

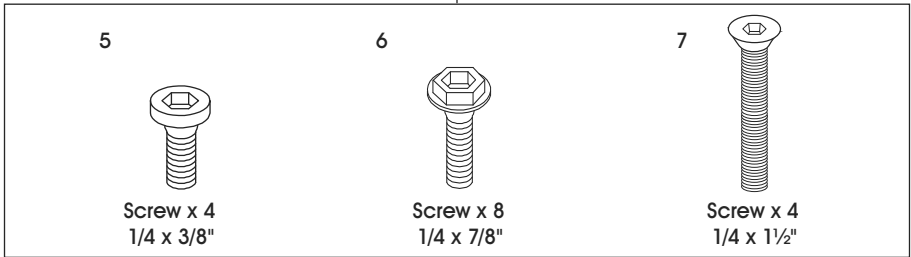

ASSEMBLY

1. Secure middle crossbars to side frames using two 1/4 x 3/8" screws (5) for each bar. (See Figure 1)
2. Align side frames with holes on underside of seat cushion and attach plates using four 1/4 x 7/8" screws (6). (See Figure 2)

NOTE: Do not fully tighten screws.

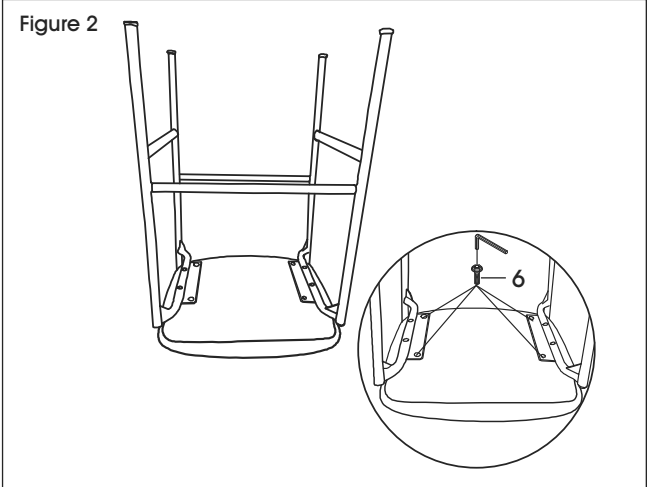
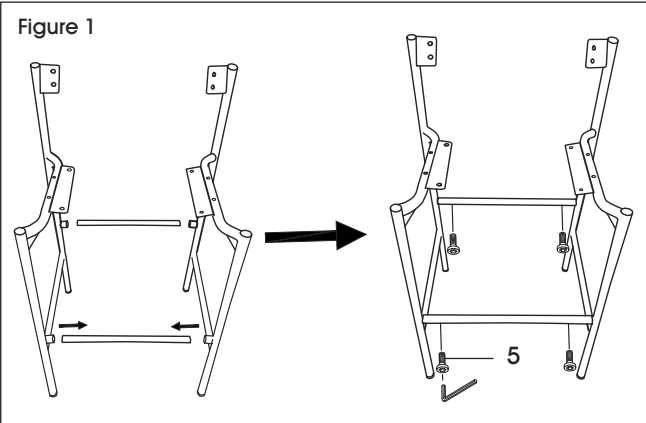

ASSEMBLY CONTINUED

3. Insert four 1/4 x 1 1/2" screws (7) through side frame tube into holes located on underside of seat cushion. (See Figure 3)

Figure 3

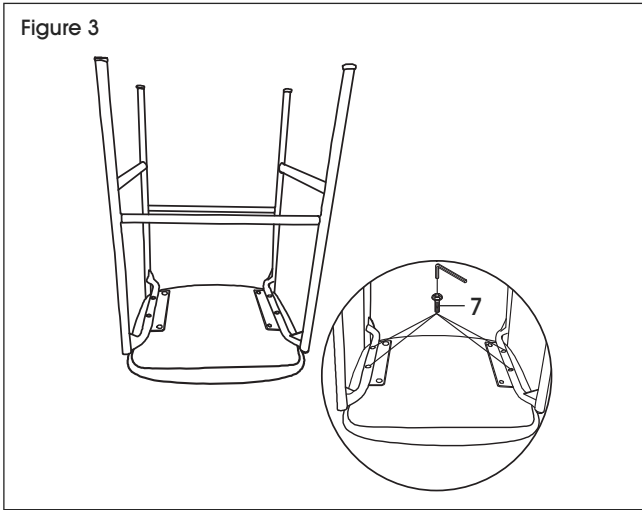

5. Lower fabric to cover screw holes. (See Figure 5)

Figure 5

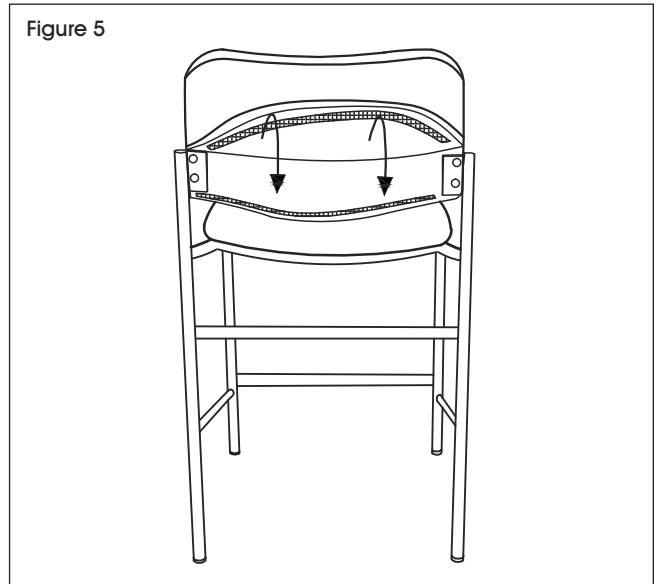

4. Lift fabric on back cushion to expose screw holes. Align side frames with holes on back cushion and attach using four 1/4 x 7/8" screws (6). (See Figure 4)

Figure 4

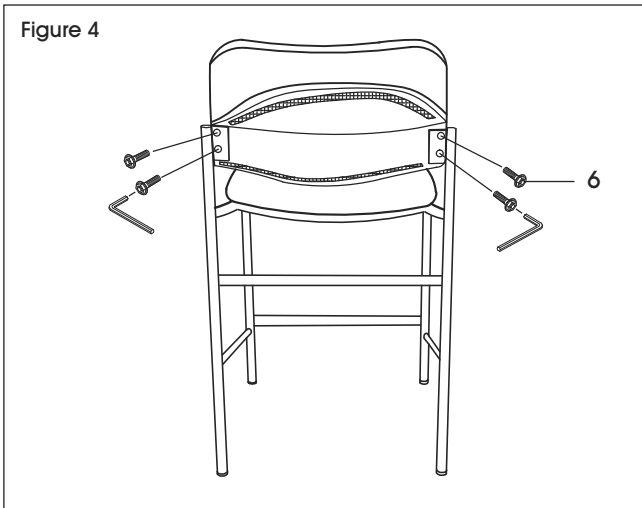

6. Use Allen wrench to fully tighten all screws.
7. Floor glides can be adjusted to compensate for uneven floors. (See Figure 6)

Figure 6

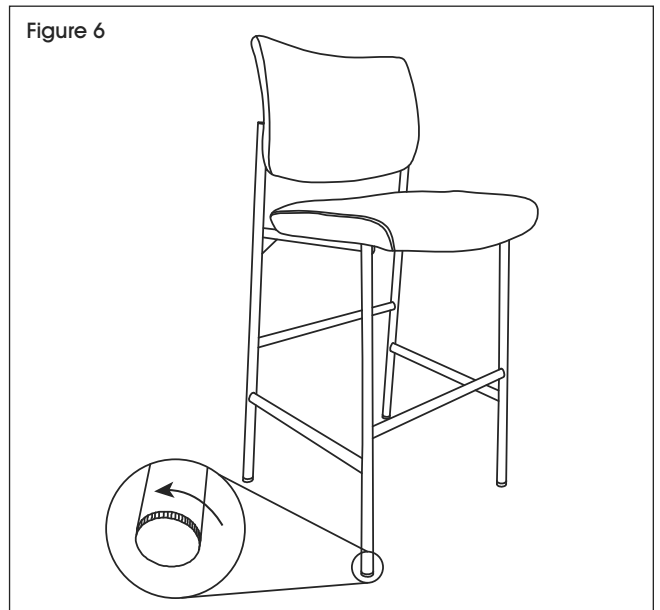

ULINE H-7060

SILLA ALTA DE TELA

800-295-5510
uline.mx

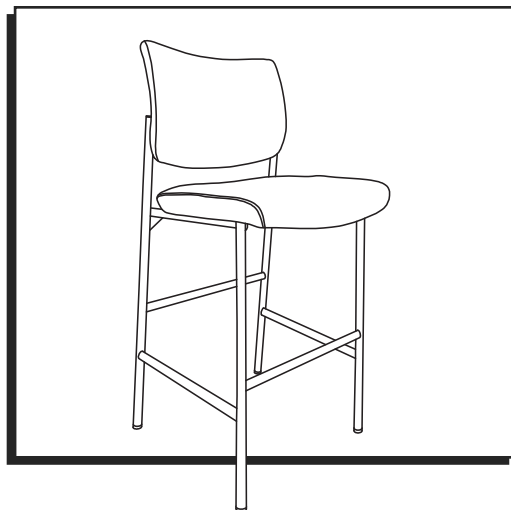

HERRAMIENTA NECESARIA



Llave Allen
(Incluida)

PARTES



1 Asiento

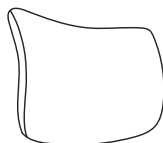

1 Respaldo

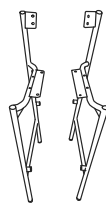

2 Armazones
Laterales

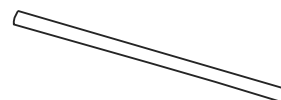

2 Barras Transversales
Intermedias

Kit de Tornillería

5

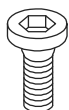

4 Tornillos
1/4 x 3/8"

6



8 Tornillos
1/4 x 7/8"

7

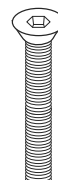

4 Tornillos
1/4 x 1 1/2"

ENSAMBLE

1. Asegure las barras transversales intermedias a los armazones laterales usando dos tornillos de 1/4 x 3/8" (5) para cada barra. (Vea Diagrama 1)

2. Alinee los armazones laterales con los orificios en la parte inferior del asiento y fije las placas usando cuatro tornillos de 1/4 x 7/8" (6). (Vea Diagrama 2)

 **NOTA:** No apriete los tornillos por completo.

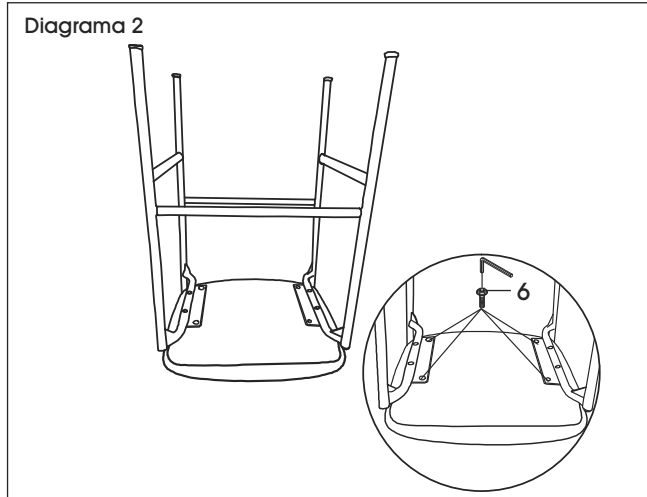
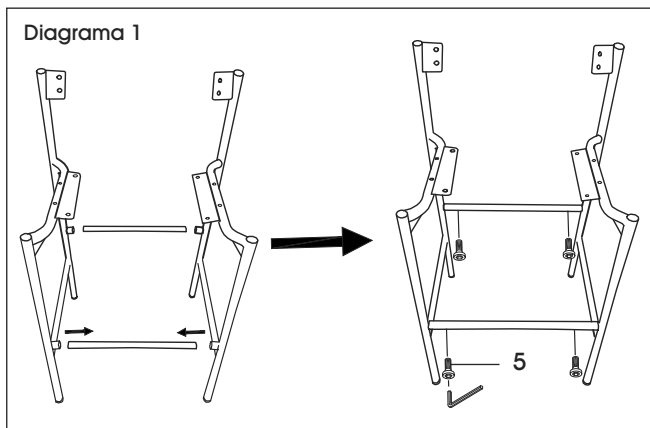

CONTINUACIÓN DEL ENSAMBLE

3. Inserte cuatro tornillos de $1/4 \times 1\frac{1}{2}$ " (7) a través del tubo del armazón lateral en los orificios ubicados en la parte inferior del asiento. (Vea Diagrama 3)

Diagrama 3

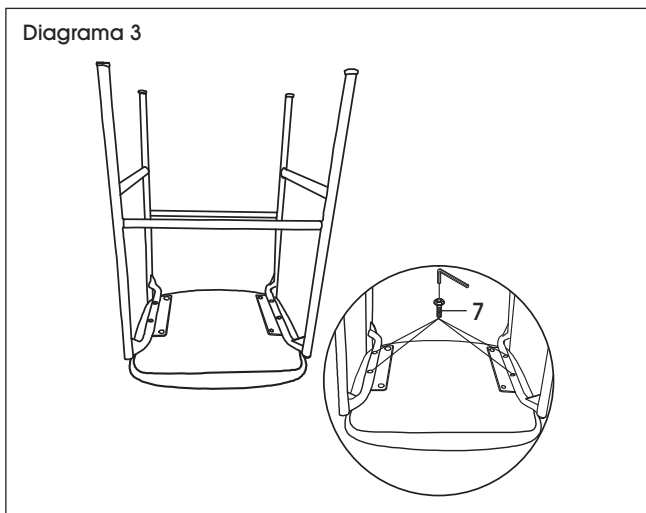

4. Levante la tela del respaldo para ver los orificios para tornillos. Alinee los armazones laterales con los orificios del respaldo y fíjelos usando cuatro tornillos de $1/4 \times 7/8$ " (6). (Vea Diagrama 4)

Diagrama 4

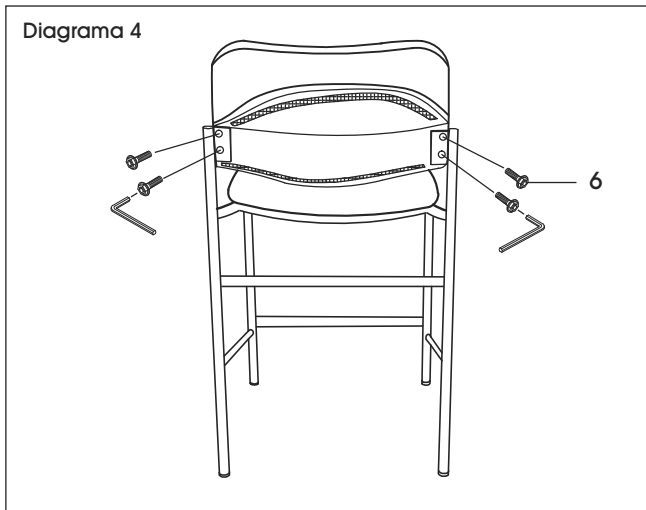

5. Baje la tela para cubrir los orificios para tornillos. (Vea Diagrama 5)

Diagrama 5

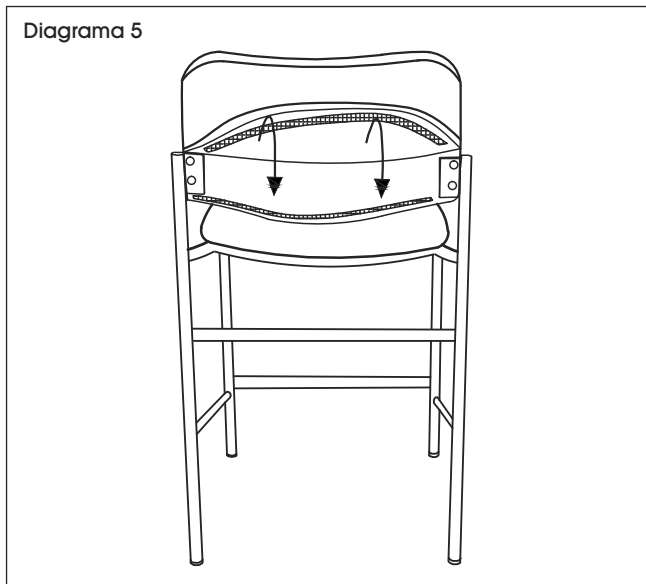

6. Utilice la llave Allen para apretar todos los tornillos.
7. Las tapas para piso se pueden ajustar para compensar los pisos irregulares. (Vea Diagrama 6)

Diagrama 6



ULINE H-7060

CHAISE HAUTE DE BAR EN TISSU

1-800-295-5510
uline.ca

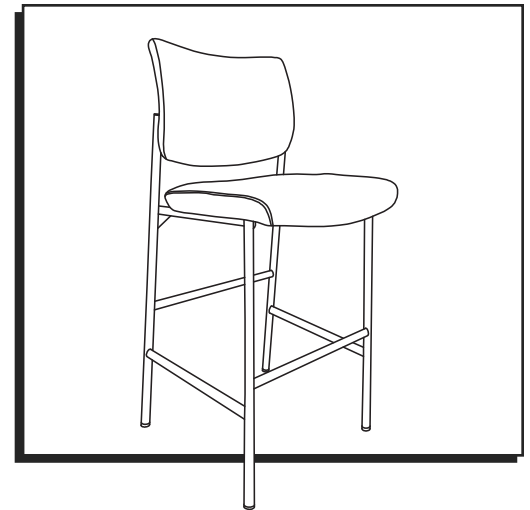

OUTIL REQUIS



Clé Allen
(inclus)

PIÈCES



Siège x 1

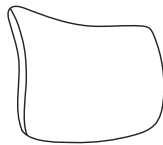

Dossier x 1

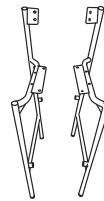

Cadre latéral x 2

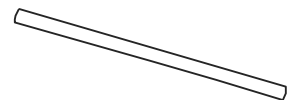

Barreau central x 2

Matériel d'installation

5

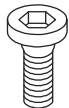

Vis x 4
1/4 x 3/8 po

6

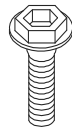

Vis x 8
1/4 x 7/8 po

7

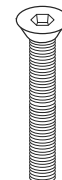

Vis x 4
1/4 x 1 1/2 po

MONTAGE

1. Fixez les barreaux centraux aux cadres latéraux avec deux vis de 1/4 x 3/8 po (5) par barreau. (Voir Figure 1)

2. Alignez les cadres latéraux sur les trous situés sous le siège et fixez les plaques avec quatre vis de 1/4 x 7/8 po (6). (Voir Figure 2)

 **REMARQUE : Ne serrez pas complètement les vis.**

Figure 1

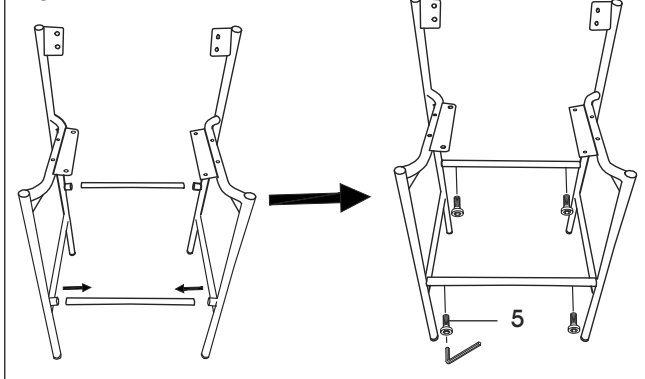
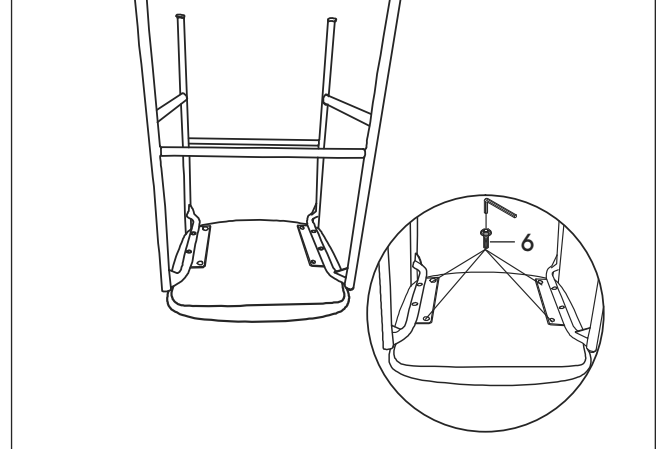

Figure 2



MONTAGE SUITE

3. Insérez quatre vis de 1/4 x 1 1/2 po (7) à travers le tube du cadre latéral dans les trous situés sous le siège. (Voir Figure 3)

Figure 3

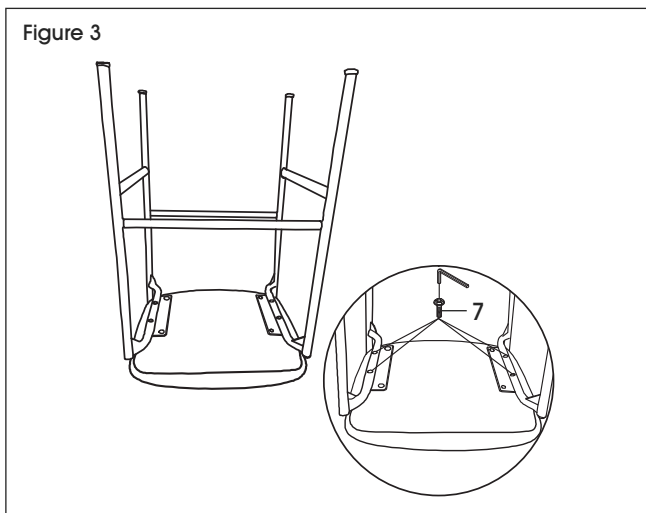

4. Soulevez le tissu du dossier pour découvrir les trous à vis. Alignez les cadres latéraux sur les trous situés sur le dossier et fixez-les avec quatre vis de 1/4 x 7/8 po (6). (Voir Figure 4)

Figure 4

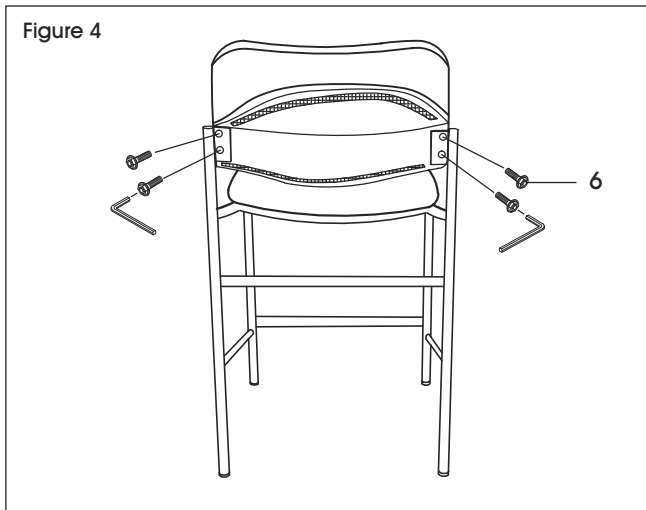

5. Remplacez le tissu pour recouvrir les trous à vis. (Voir Figure 5)

Figure 5

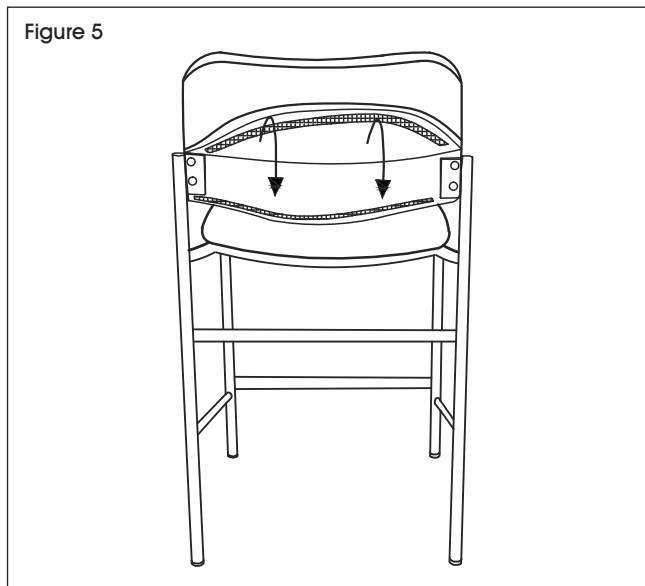

6. Utilisez la clé Allen pour serrer complètement toutes les vis.
7. Les patins peuvent être réglés pour compenser les inégalités du plancher. (Voir Figure 6)

Figure 6

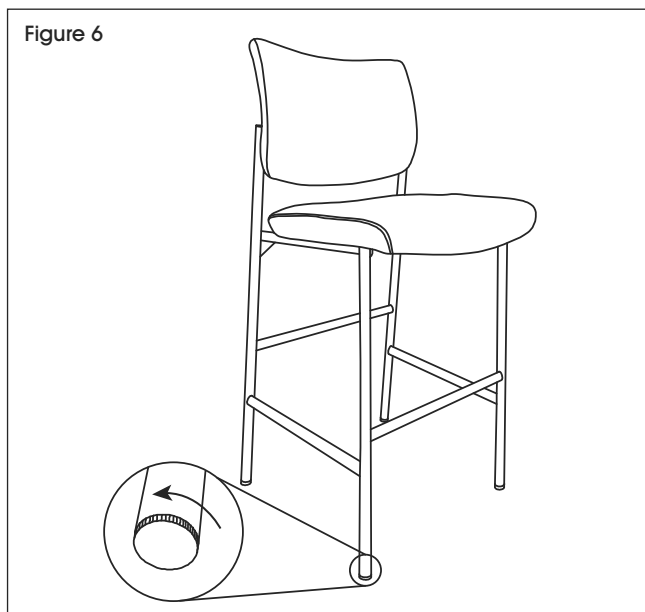

ULINE

1-800-295-5510
uline.ca