

ULINE H-7180, H-7806
H-9023

1-800-295-5510
uline.com

MAGNETIC GLASS DRY ERASE BOARD

3 x 2', 4 x 3'



Two Person Assembly Required

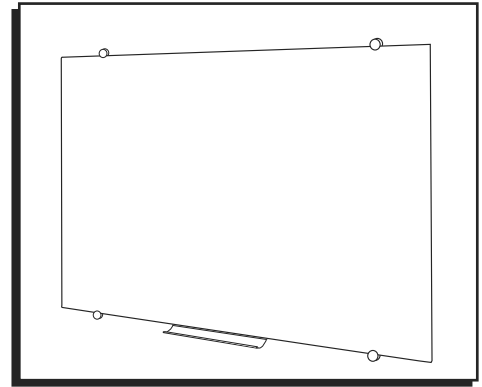

TOOLS NEEDED



Power Drill

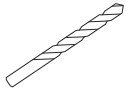

1/4", 5/16" and
1/8" Drill Bits



Phillips
Screwdriver Bit



Chalkline



Stud Finder

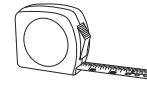

Tape Measure



Level

PARTS

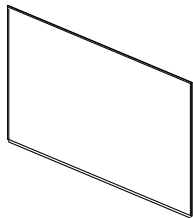

Glass Board x 1

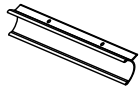

Aluminum Tray x 1

Board Hardware Kit



Wall Mount Bracket
Outer Cap x 4

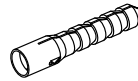

Plastic Anchor x 4

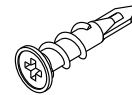

Drywall Anchor x 4

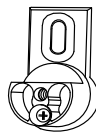

Wall Mount Bracket x 4

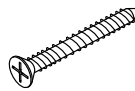

CS Screw x 4

Marker Tray Hardware Kit

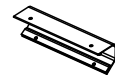

Tray Mount x 1



Phillips Tray Screw x 2

SETUP



WARNING! Glass dry erase boards are made of safety glass, but improper handling and installation may cause serious injury if the board shatters. Proper installation will require at least two people.



IMPORTANT! Do not use unless all screws are tight. At least every six months, check all screws to be sure they are tight.

1. Make sure wall is flat. On drywall and stud walls, always hit studs (if possible). A minimum of 1/2" drywall is required. Use correct type anchor and predrill for the wall type.

INSTALLATION

1. Determine what type of wall board will be mounted on.
2. Measure length, width and center lines of board and wall. Determine the desired height off the floor that bottom of board is to be at. Most boards are mounted about 36" off the floor. (See Figure 1)
3. With help, hold board up in position and draw a line around the perimeter. Make sure these drawn lines are parallel with the ceiling and floor.



NOTE: If wall has studs, mount into as many studs as possible.

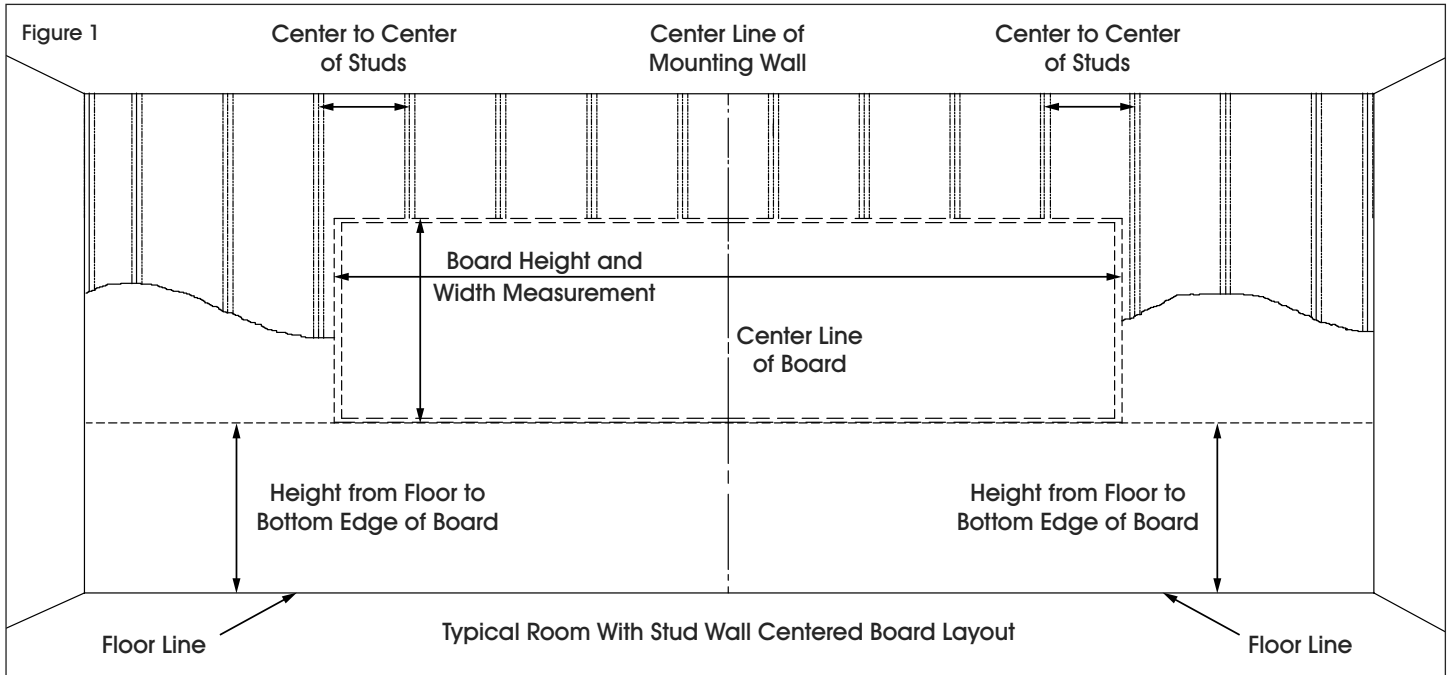

MOUNTING

1. Identify and separate all the parts and hardware.
2. Pick the correct type of mounting hardware and anchors for wall type.
3. Measure up 1 1/4" above the bottom line and draw another line that is parallel. Measure in about 6" from each side and install two bottom wall mount brackets using two CS screws. (See Figures 2-3)



NOTE: The wall mount brackets should be placed on 16" centers (as a minimum) and not more than 24" (as a maximum).

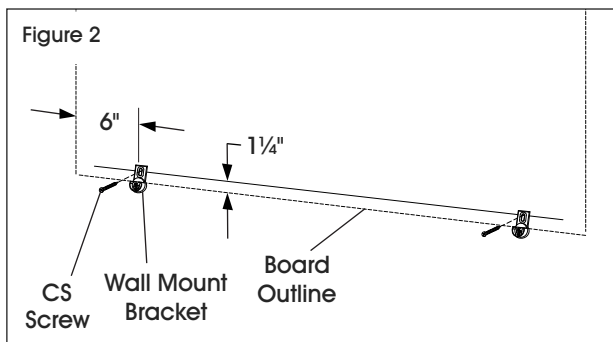
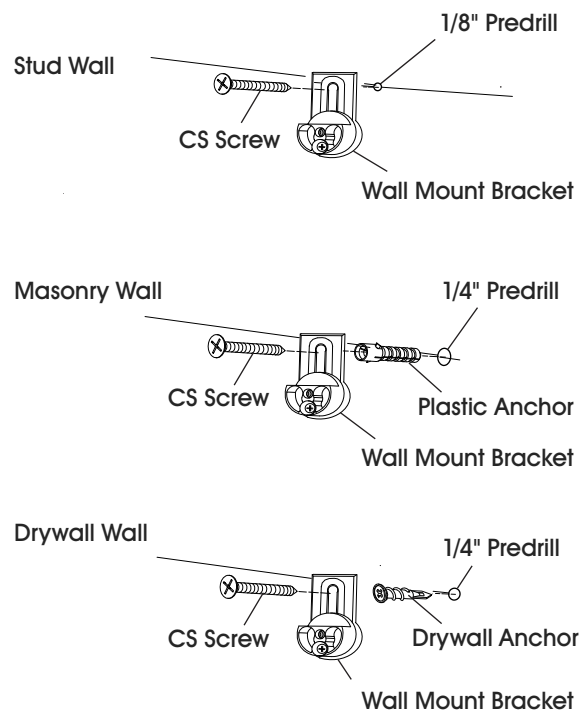
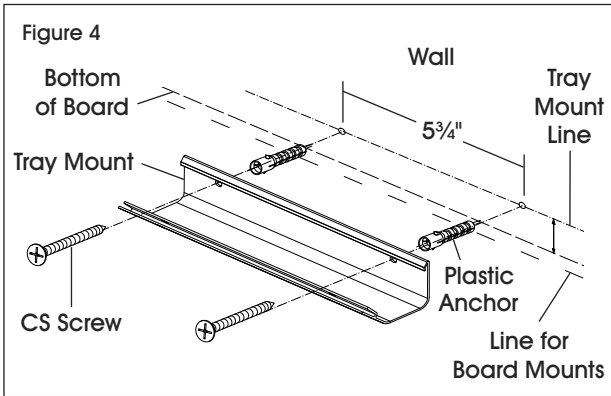

Figure 3



INSTALLATION CONTINUED

- Determine desired tray location and mark a line 1" above the bottom edge of board. Drill two 5/16" diameter holes in wall 5 3/4" apart.
- Push in two plastic anchors into predrilled holes. Place tray mount over plastic anchors and secure with two CS screws. (See Figure 4)



- Place aluminum tray in the front slot of tray mount and align the holes. Secure aluminum tray to tray mount using two Phillips tray screws. (See Figure 5)

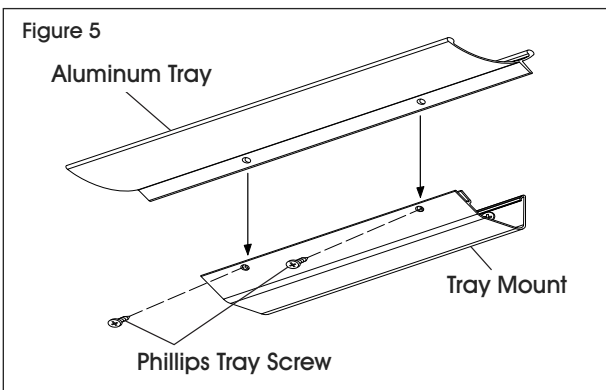

- Measure down 3/4" from the top line and draw another line that is parallel. Measure in about 6" from each side and install top two wall mount brackets using two CS screws. (See Figure 6)

NOTE: Leave the top wall mount brackets pushed up.

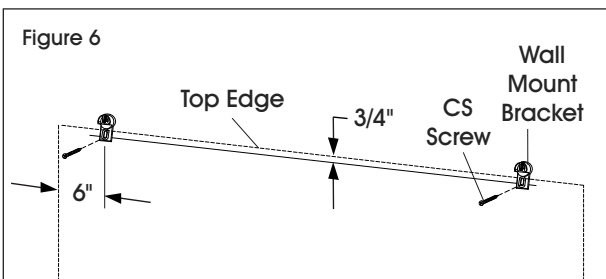

- Apply self-adhesive pads to back of board. Peel one side of the backer from the pad and apply to the board as shown. (See Figure 7) Then peel the other side before mounting on the wall. Carefully position the panel left to right before applying pressure against the wall.

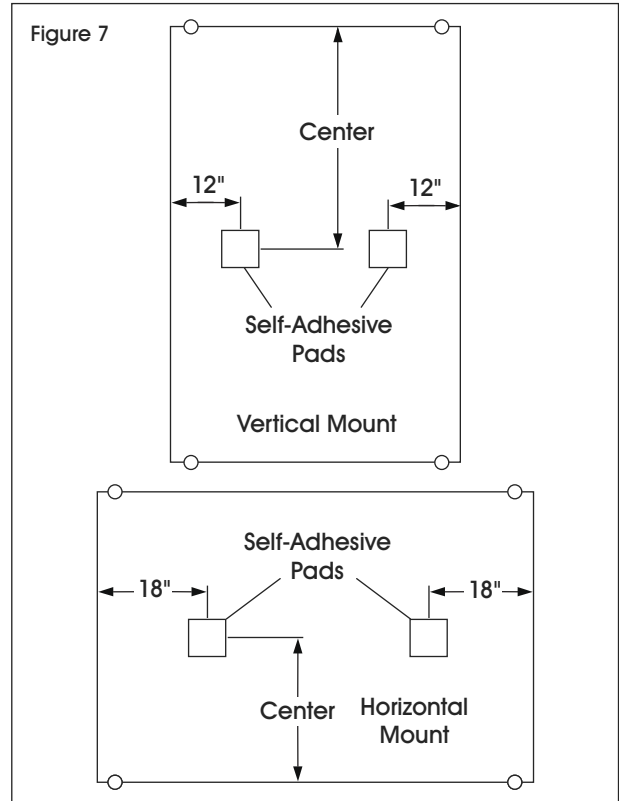

- Place the glass board on bottom wall mount brackets and screw in the two wall mount bracket outer caps to secure. Tilt the glass board back and push down the top wall mount brackets onto the board's top edge. Secure board in place by screwing in the two top wall mount bracket outer caps. (See Figure 8)

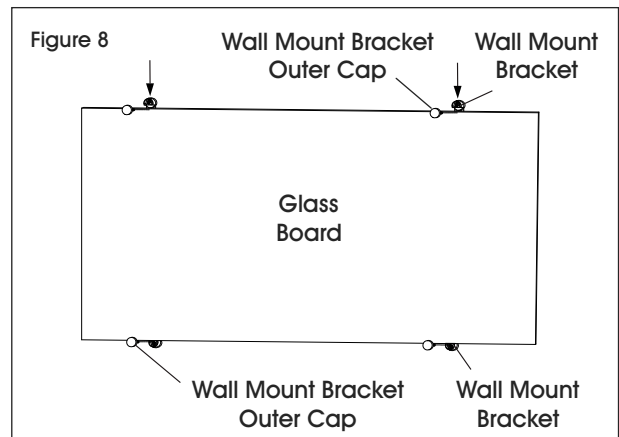

ULINE

1-800-295-5510
uline.com

ULINEH-7180, H-7806
H-9023**PIZARRÓN BLANCO DE
VIDRIO MAGNÉTICO**

3 x 2', 4 x 3'

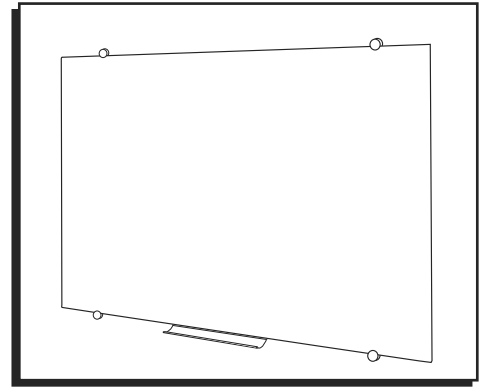
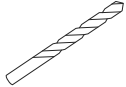

Se debe ensamblar entre dos personas

800-295-5510
uline.mx**HERRAMIENTAS NECESARIAS**Taladro
EléctricoBrocas de 1/4",
5/16" y 1/8"Broca de Punta
de Cruz

Tiralíneas con Gis

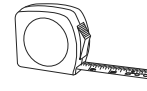
Detector
de Polines

Cinta de Medir

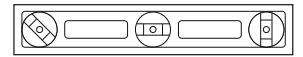

Nivel

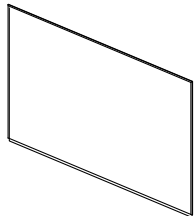
PARTES

1 Pizarrón de Vidrio

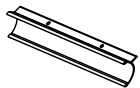
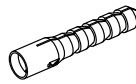
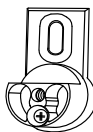
1 Bandeja de
AluminioKit de Tornillería para
el Pizarrón4 Tapas Exteriores
de los Soportes para
Instalación en Pared4 Taquetes de
Plástico4 Taquetes para
Paneles de Yeso4 Soportes para
Instalación en Pared

4 Tornillos

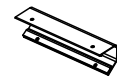
Kit de Tornillería de la
Bandeja para Marcadores1 Montaje de la
Bandeja2 Tornillos de Cruz para
Bandeja**CONFIGURACIÓN**

¡ADVERTENCIA! Los pizarrones blancos de vidrio están hechos de vidrio de seguridad, pero si se maltratan o instalan de manera inapropiada pueden causar lesiones serias si el pizarrón se estrella. Se requieren al menos dos personas para instalar el pizarrón de manera adecuada.



¡IMPORTANTE! No lo utilice al menos que los tornillos estén bien apretados. Verifique al menos cada seis meses que todos los tornillos estén apretados.

1. Asegúrese de que la pared esté pareja. En paredes con paneles de yeso o polines, es necesario, en lo posible que quede sujeta a los polines. Se requiere un pared de panel de yeso de mínimo 1/2". Utilice los taquetes adecuados y pretaladree según el tipo de pared.

INSTALACIÓN

1. Determine el tipo de pared en la cual se instalará el pizarrón.
2. Mida el largo, ancho y las líneas centrales del pizarrón y la pared. Determine la altura desde el suelo a la cual la parte inferior del pizarrón deberá quedar. La mayoría de los pizarrones se instalan aproximadamente a 90 cm (36") del suelo. (Vea Diagrama 1)

3. Con ayuda de otra persona, coloque el pizarrón en la posición deseada y dibuje una línea alrededor del perímetro. Asegúrese de que estas líneas dibujadas queden paralelas con el techo y el piso.



NOTA: Si la pared tuviera polines utilice tantos como sea posible.

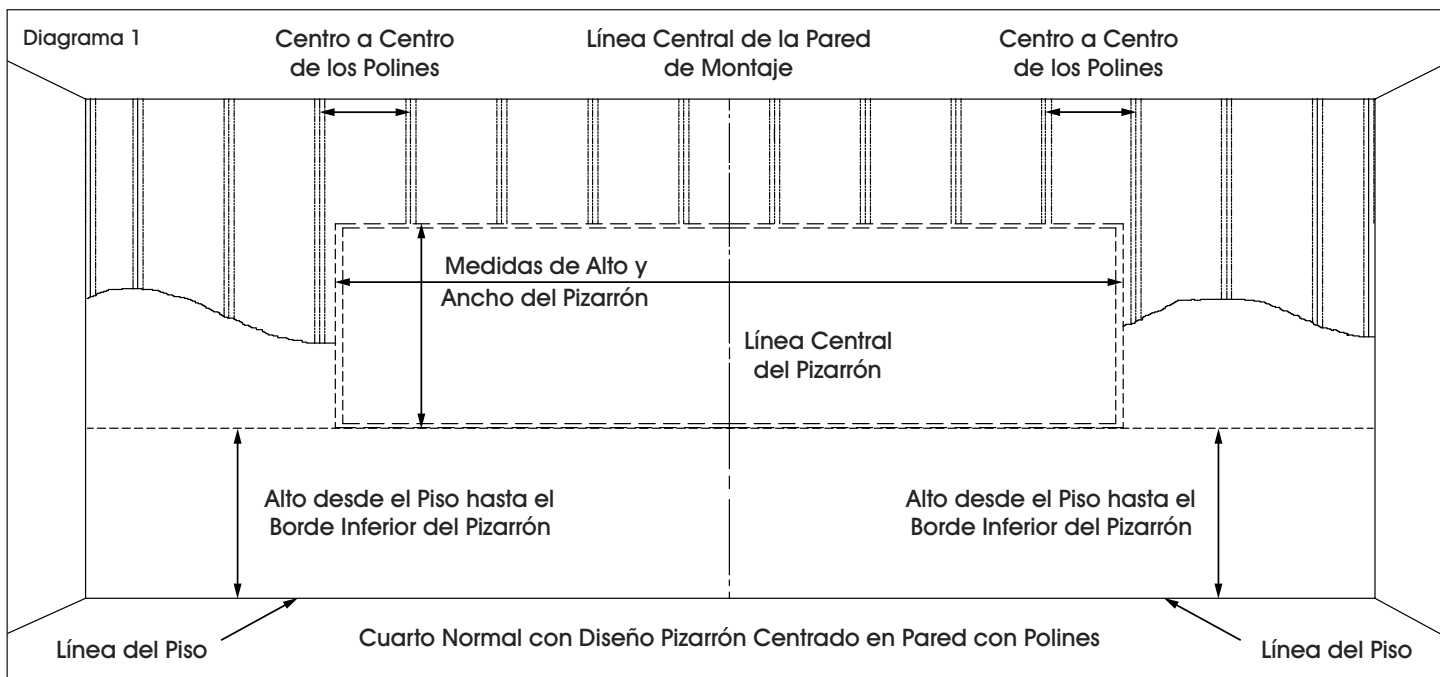

INSTALACIÓN

1. Identifique y separe todas las partes y los accesorios.
2. Elija la tornillería de instalación y los taquetes adecuados para el tipo de pared.
3. Mida 1 1/4" por encima de la línea inferior y dibuje otra línea paralela. Mida aproximadamente 6" desde cada lado e instale dos soportes para instalación en pared inferiores utilizando dos tornillos. (Vea Diagramas 2-3)



NOTA: Los soportes para instalación en pared se deben colocar en centros de 16" (como mínimo) y no más de 24" (como máximo).



Diagrama 3



CONTINUACIÓN DE INSTALACIÓN

- Determine la ubicación deseada de la bandeja y marque una línea a 1" por encima del borde inferior del pizarrón. Taladre dos orificios con diámetro de 5/16" en la pared a 5 3/4" de distancia.
- Coloque dos taquetes de plástico en los orificios pretaladrados. Coloque el montaje de la bandeja sobre los taquetes de plástico y asegúrelo con dos tornillos. (Vea Diagrama 4)

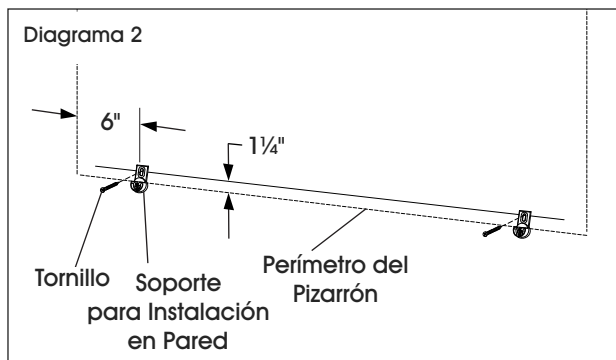
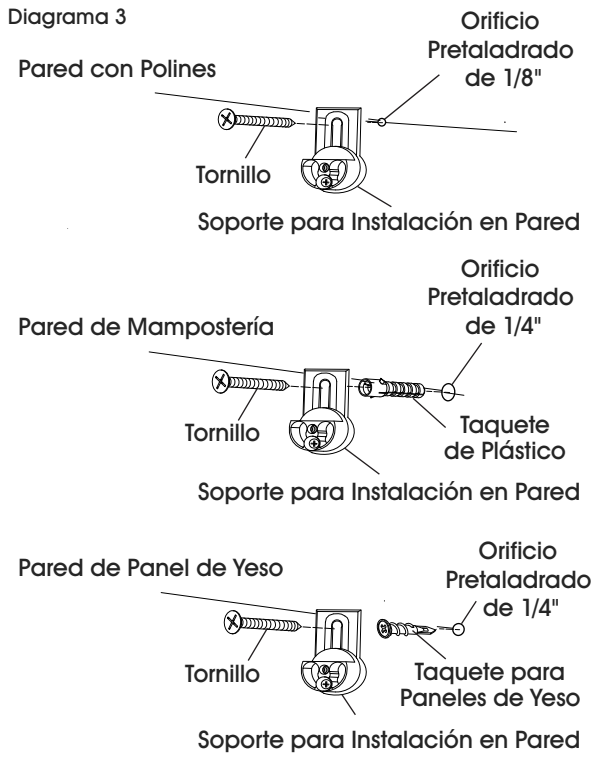
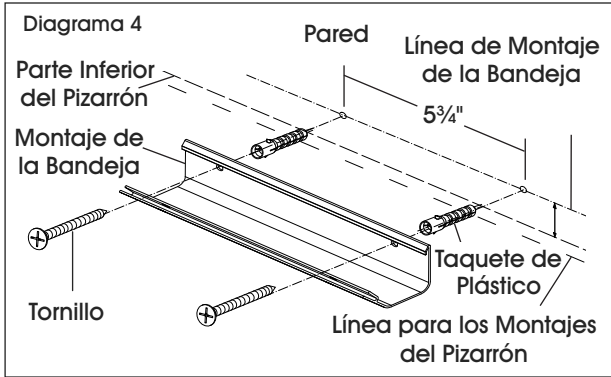

- Coloque la bandeja de aluminio en la ranura frontal del montaje y alinee los orificios. Asegure la bandeja de aluminio al montaje utilizando dos tornillos de cruz. (Vea Diagrama 5)

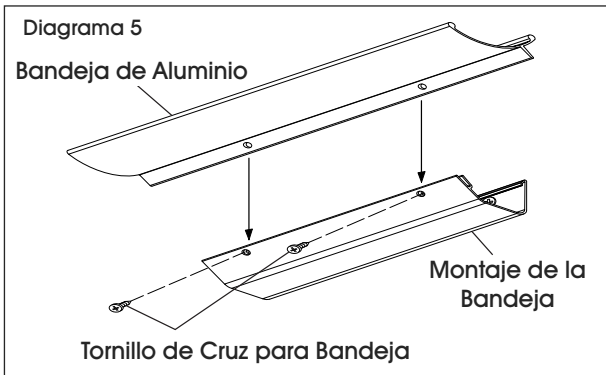

- Mida 3/4" hacia abajo de la línea superior y trace otra línea paralela. Mida hacia dentro aproximadamente 6" desde cada lado e instale dos soportes para instalación en pared superiores con dos tornillos. (Vea Diagrama 6)

NOTA: Mantenga los soportes para instalación en pared superiores presionados hacia arriba.

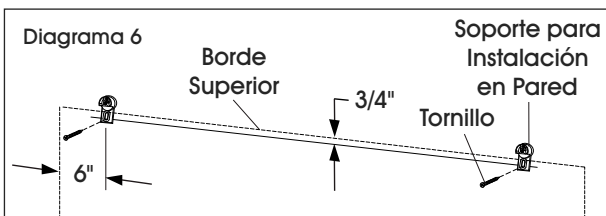

- Pegue las almohadillas autoadhesivas en la parte posterior del pizarrón. Despegue un lado de la lámina y aplíquela al pizarrón como se muestra. (Vea Diagrama 7) Luego, despegue el otro lado antes de instalarlo a la pared. Coloque cuidadosamente el panel de izquierda a derecha antes de presionarlo contra la pared.

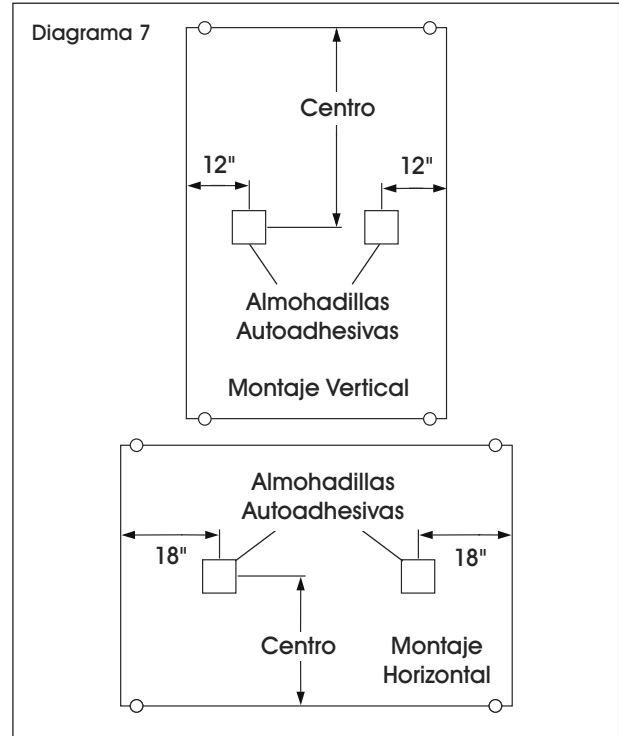

- Coloque el pizarrón de vidrio en los soportes para instalación en pared inferiores y atornille las dos tapas exteriores de los soportes para asegurarlo. Incline el pizarrón de vidrio hacia atrás y presione los soportes para instalación en pared superiores hacia abajo sobre el borde superior del pizarrón. Asegure el pizarrón en su lugar atornillando las dos tapas de los soportes para instalación en pared superiores. (Vea Diagrama 8)

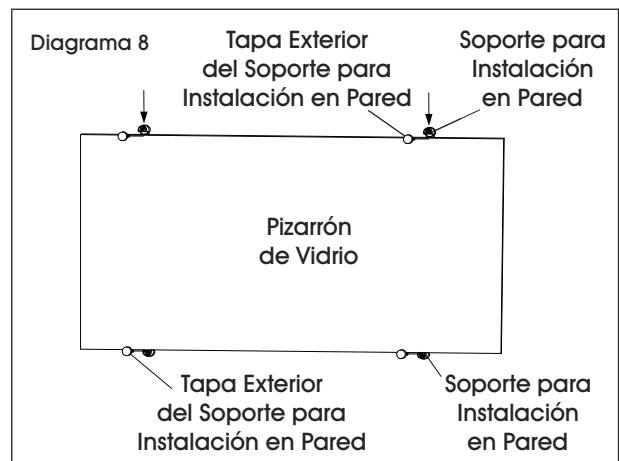

ULINE

800-295-5510
uline.mx

ULINEH-7180, H-7806
H-90231-800-295-5510
uline.ca**TABLEAU MAGNÉTIQUE
EFFAÇABLE À SEC EN VERRE**

3 x 2 po, 4 x 3 po

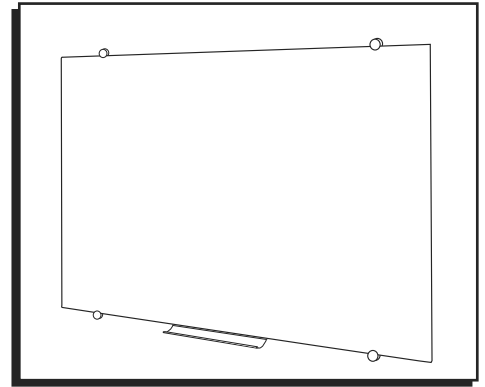
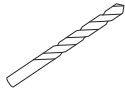

Un montage à deux personnes est recommandé.

**OUTILS REQUIS**Perceuse
électriqueMèches de 1/4 po,
5/16 po et 1/8 poMèche de
tournevis
cruciforme

Cordeau

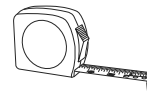
Détecteur de
montants

Ruban à mesurer

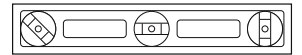

Niveau

PIÈCES

Tableau en verre x 1

Porte-marqueurs
en aluminium x 1Matériel d'installation
du tableauCapuchon extérieur
pour support de fixation
murale x 4Ancrage en
plastique x 4Ancrage pour
cloison sèche x 4Support de fixation
murale x 4

Vis noyée x 4

Matériel d'installation du
porte-marqueursSupport de fixation pour
porte-marqueurs x 1Vis cruciforme pour
porte-marqueurs x 2**INSTALLATION****AVERTISSEMENT!** Les tableaux effaçables en verre sont fabriqués en verre de sécurité, mais un maniement et une installation inappropriés peuvent résulter en blessures graves en cas de brisure du tableau. Une installation adéquate nécessite au moins deux personnes.**IMPORTANT!** N'utilisez pas avant que toutes les vis soient serrées. Assurez-vous du serrage des vis au minimum tous les six mois.

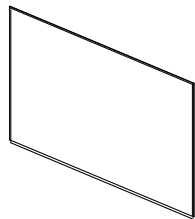
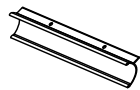
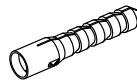
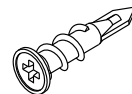
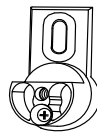
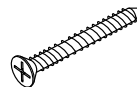
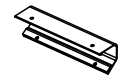
1. Assurez-vous que le mur est plat. Sur les cloisons sèches et murs à colombages, visez toujours les montants (si possible). La cloison sèche doit avoir une épaisseur minimale de 1/2 po. Utilisez le type d'ancrage approprié au type de mur et percer les avant-trous.

INSTALLATION

1. Déterminez le type de mur sur lequel installer le tableau.
2. Mesurez la longueur et la largeur, puis centrez les lignes/alignez le tableau et le mur. Déterminez à quelle distance du sol doit se trouver le bas du tableau. La plupart des tableaux se montent à environ 36 po du sol. (Voir Figure 1)
3. Faites-vous assister pour tenir le tableau sur le mur et tracez une ligne le long de son périmètre. Assurez-vous que les lignes tracées sont parallèles au sol et au plafond.



REMARQUE : Si le mur possède des montants, utilisez-les autant que possible.

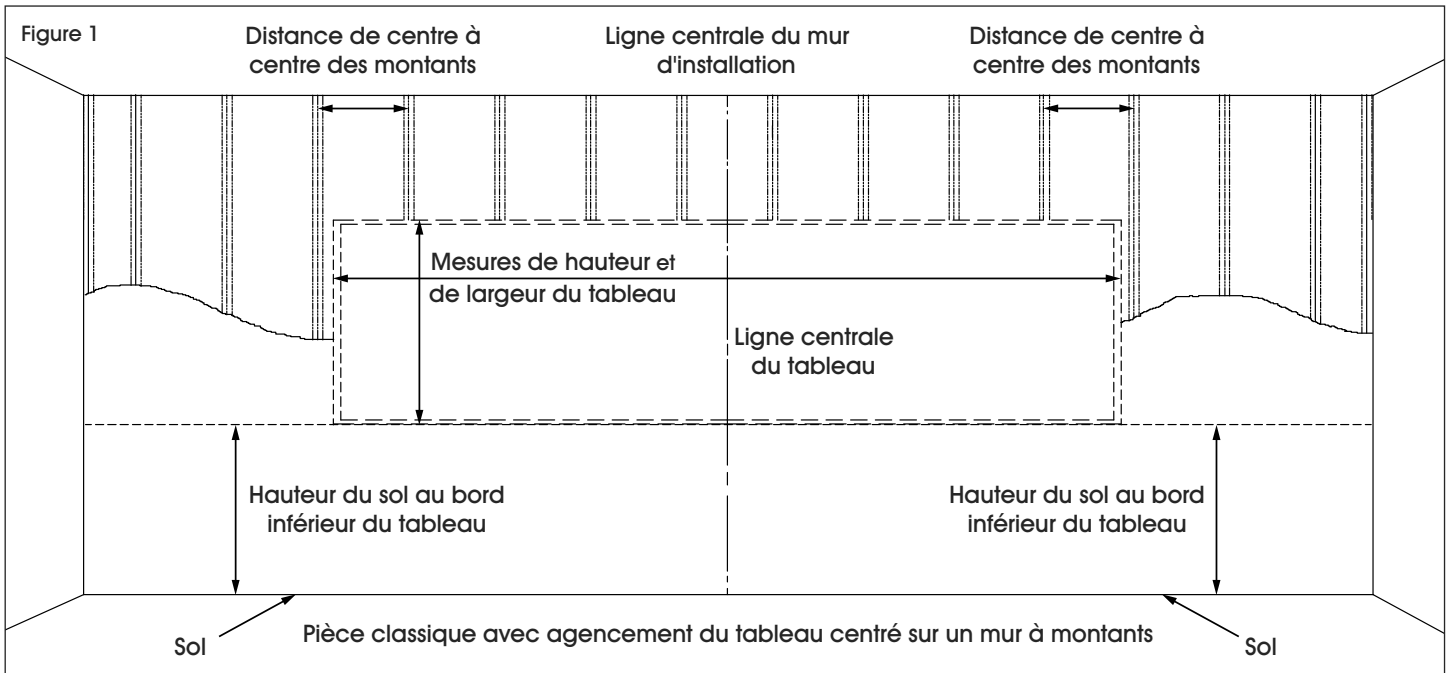

INSTALLATION

1. Identifiez et séparez les pièces et le matériel d'installation.
2. Sélectionnez le type de matériel d'installation et les ancrages appropriés au type de mur.
3. Mesurez et tracez une ligne parallèle à 1 ¼ po en dessous de la ligne supérieure. Mesurez 6 po de chaque côté et installez les deux supports de fixation murale inférieurs à l'aide de deux vis noyées. (Voir Figures 2 et 3)



REMARQUE : Les centres des supports de fixation murale doivent être espacés de 16 po (minimum) et pas plus de 24 po (maximum).

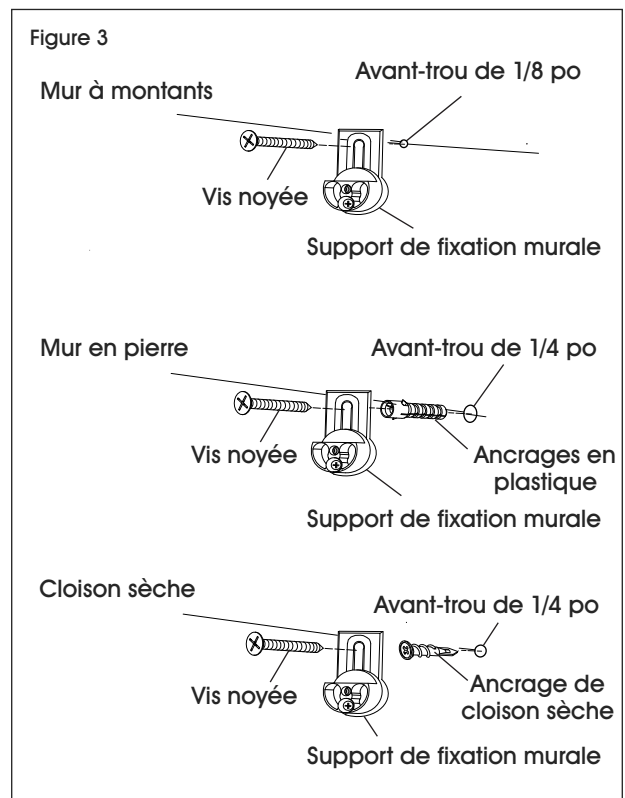
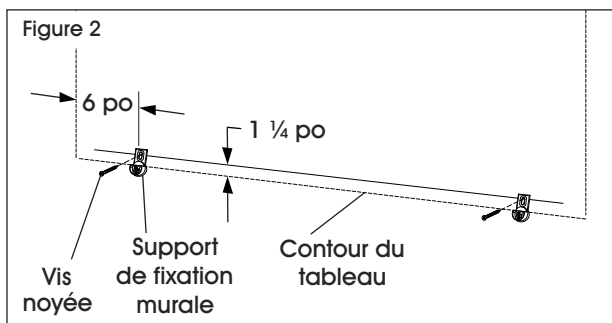

INSTALLATION SUITE

- Déterminez l'emplacement du porte-marqueur et tracez une ligne à 1 po au-dessus du bord inférieur du tableau. Percez deux trous d'un diamètre de 5/16 po et espacés de 5 3/4 po.
- Poussez deux ancrages en plastique dans les avant-trous. Placez les fixations du porte-marqueurs par dessus les ancrages en plastique et fixez le tout à l'aide de deux vis noyées. (Voir Figure 4)

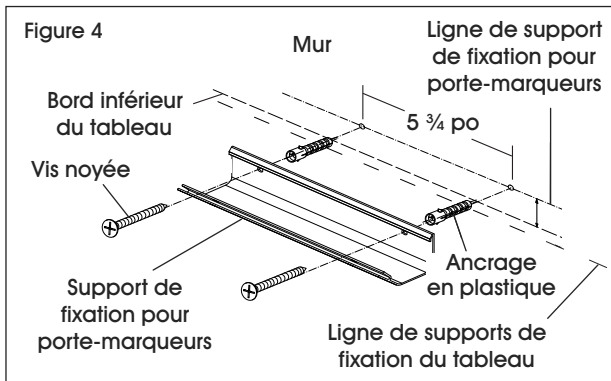

- Placez le plateau en aluminium dans la fente avant de la fixation du porte-marqueurs et alignez les trous. Fixez le plateau en aluminium à la fixation du porte-marqueurs à l'aide des deux vis cruciformes pour plateau. (Voir Figure 5)

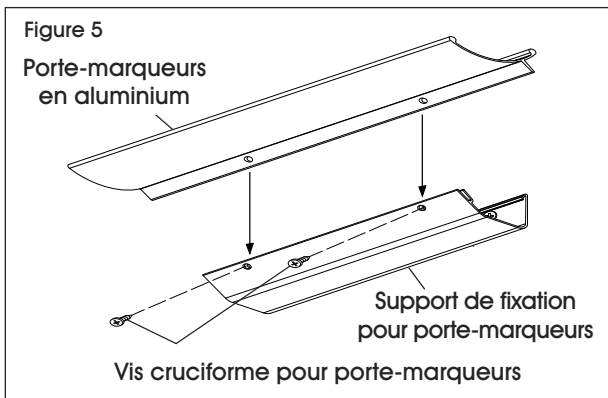

- Mesurez et tracez une ligne parallèle à 3/4 po en dessous de la ligne supérieure. Mesurez 6 po de chaque côté et installez les deux supports de fixation murale supérieurs à l'aide de deux vis noyées. (Voir Figure 6)

REMARQUE : Maintenez les supports de fixation murale poussés vers le haut.

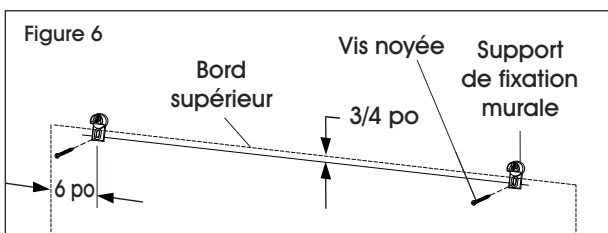

- Fixez des tampons autoadhésifs au dos du tableau. Pelez un côté de la pellicule au dos du tampon et fixez au tableau comme illustré. (Voir Figure 7). Pelez ensuite l'autre côté avant de fixer au mur. En faisant preuve de précaution, positionnez le panneau en commençant par la gauche vers le droite avant de pousser contre le mur.

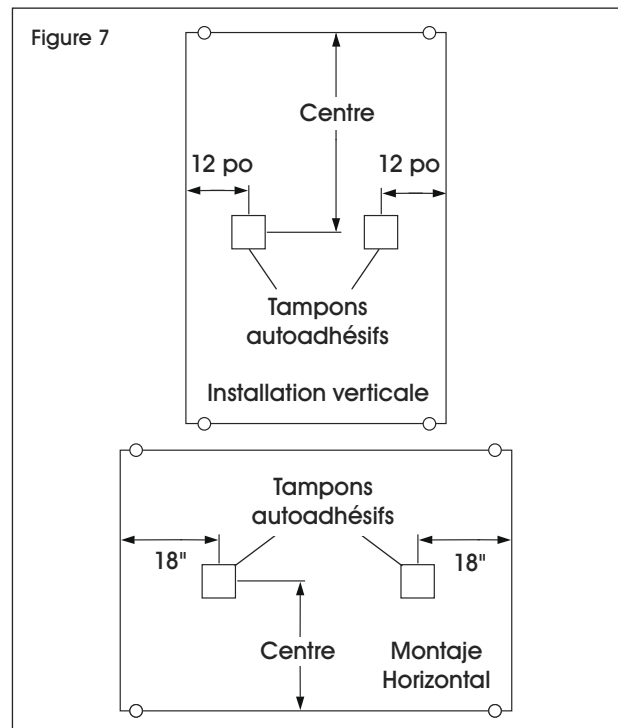

- Placez le panneau en verre sur les supports de fixation murale inférieurs, puis vissez les deux capuchons extérieurs afin de le sécuriser. Inclinez le tableau vers l'arrière et poussez les supports de fixation murale supérieurs vers le bas sur le bord supérieur du tableau. Sécurisez le panneau en vissant les deux capuchons extérieurs dans les supports de fixation murale supérieurs. (Voir Figure 8)

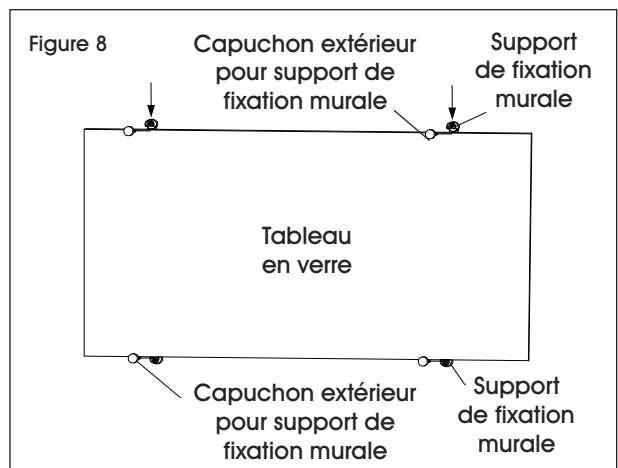

ULINE

1-800-295-5510
uline.ca