

ULINE H-7490, H-7491

STAINLESS STEEL SERVICE CART

1-800-295-5510
uline.com

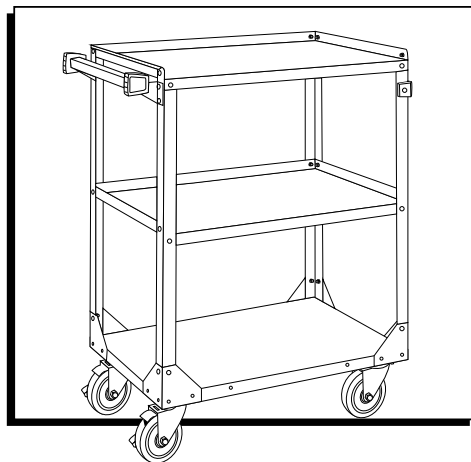

TOOLS NEEDED

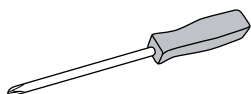

Phillips Screwdriver

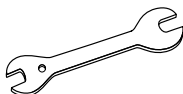

8 mm Wrench

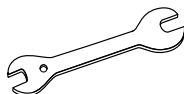

1/2" Wrench

PARTS

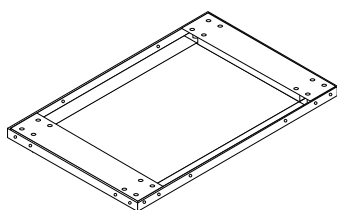

Bottom Shelf x 1

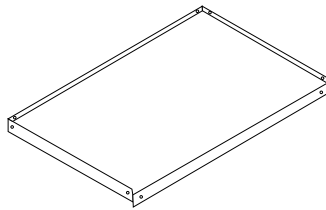

Middle Shelf x 1

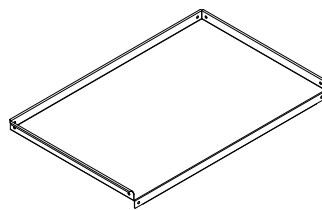

Top Shelf x 1

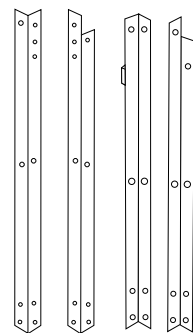

Support x 4



Handle x 1



Small Phillips Head Bolt x 24



Medium Phillips Head Bolt x 4 (For Handle)

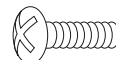

Large Phillips Head Bolt x 16



Swivel Caster with Brake x 2



Swivel Caster x 2



Bottom Shelf Plate x 4

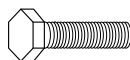

Hex Bolt x 16



Locknut x 28



Lock Washer x 16



Flat Washer x 16

ASSEMBLY

1. Attach casters to bottom shelf using hex bolts, lock washers and flat washers. Do not tighten fully. (See Figure 1)



NOTE: Make sure both swivel with brake casters are on one end of the cart and both swivel casters are on other.

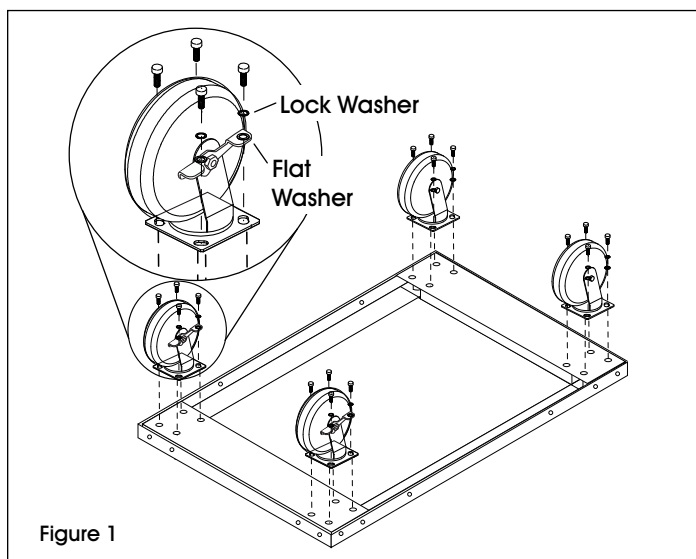

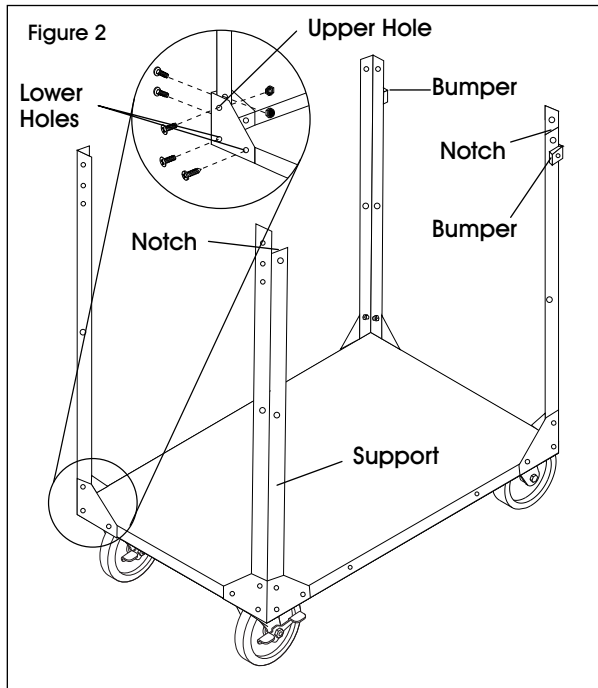

Figure 1

ASSEMBLY CONTINUED

2. Insert large Phillips head bolts through lower holes in bottom shelf plate. Thread through support and into threaded inserts in bottom shelf. Then, insert small Phillips head bolts through upper holes in bottom shelf plate and support. Secure with locknuts. (See Figure 2)

 **NOTE:** Make sure that two supports with notch at top of support are facing each other on opposite ends. Supports with rubber bumper should also be on same side.



3. Attach middle shelf to supports with small Phillips head bolts and locknuts. Make sure side of shelf without lip is on same side as supports with notch. (See Figure 3)

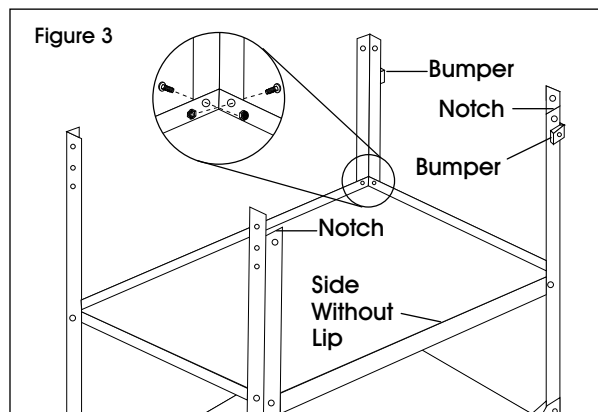

4. Attach handle to supports without bumpers using medium Phillips head bolts and locknuts. Brackets on handle that bolts go through should be on inside of support. (See Figure 4)

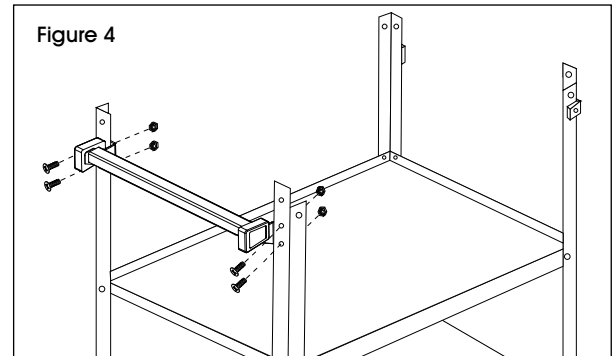

5. Attach top shelf to supports with small Phillips head bolts and locknuts. Make sure side of top shelf without lip is on same side as supports with notch. Tighten all bolts fully. (See Figure 5).

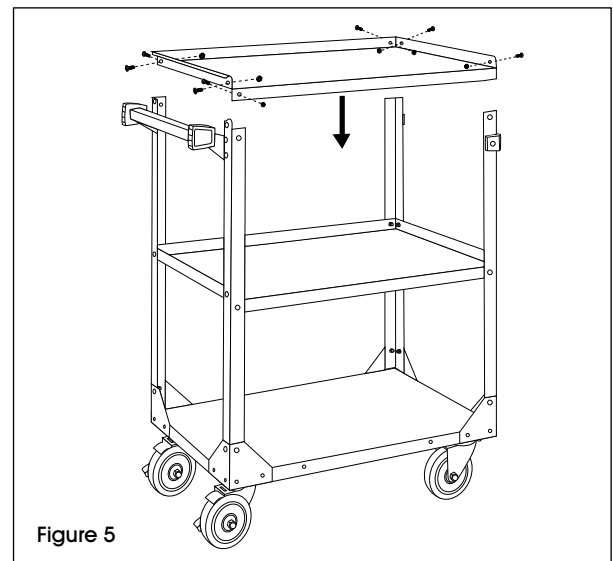

ULINE

1-800-295-5510
uline.com

ULINE H-7490, H-7491

CARRITO DE SERVICIO DE ACERO INOXIDABLE

800-295-5510
uline.mx

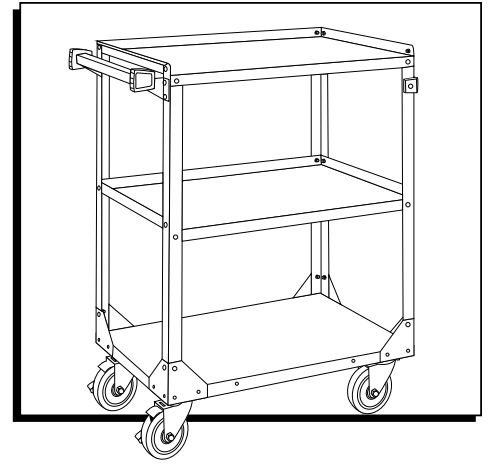

HERRAMIENTAS NECESARIAS

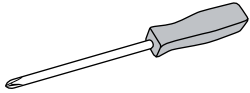

Desarmador de Cruz

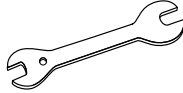

Llave de 8 mm

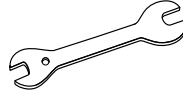

Llave de 1/2"

PARTES

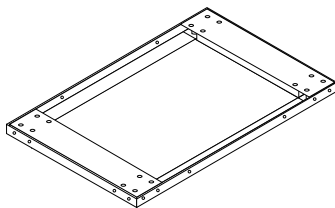

1 Repisa Inferior

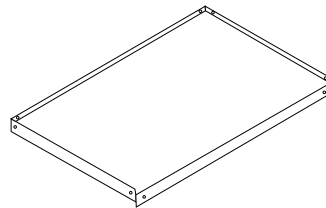

1 Repisa Intermedia

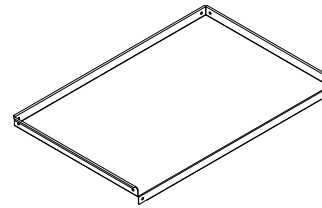

1 Repisa Superior

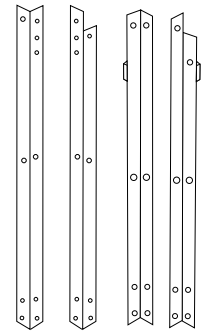

4 Soportes

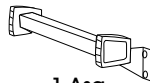

1 Asa



24 Pernos Chicos de Cruz



4 Pernos Medianos de Cruz (Para Asa)



16 Pernos Grandes de Cruz



2 Ruedas Giratorias con Freno



2 Rueda Giratoria



4 Placas para Repisa Inferior

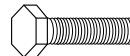

16 Pernos Hexagonales



28 Contratuercas



16 Rondanas de Bloqueo



16 Rondanas Planas

ENSAMBLE

1. Fije las ruedas a la repisa inferior con pernos hexagonales, rondanas de bloqueo y rondanas planas. No apriete por completo. (Vea Diagrama 1)



NOTA: Asegúrese de que las ruedas giratorias estén en el mismo lado del carrito y las ruedas giratorias con freno estén en el otro lado.





Diagrama 1

CONTINUACIÓN DE ENSAMBLE

2. Inserte los pernos grandes de cruz en los orificios inferiores de la placa para repisa inferior. Páselos a través del soporte y dentro de los insertos roscados de la repisa inferior. Luego inserte los pernos chicos de cruz en el orificio superior de la placa para repisa inferior y soporte. Asegure con contratuercas. (Vea Diagrama 2)

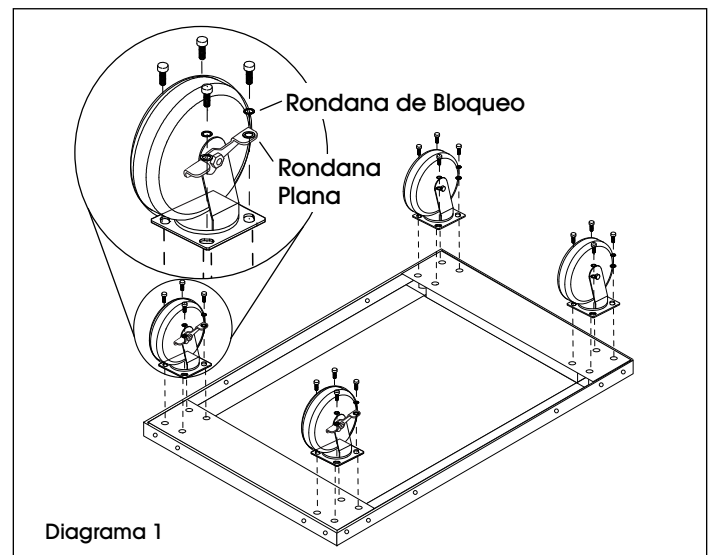
 **NOTA:** Asegúrese de que dos soportes con muesca en la parte superior del soportes estén uno frente al otro en extremos opuestos. Los soportes con parachoques de caucho también deben estar en el mismo lado.

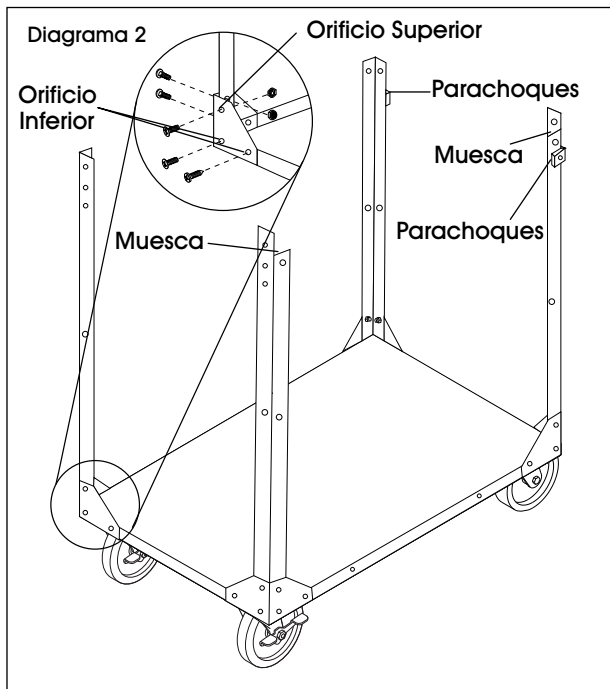

3. Fije la repisa intermedia a los soportes con pernos chicos de cruz y contratuercas. Asegúrese de que el lado de la repisa sin reborde esté en el mismo lado de los soportes sin muesca. (Vea Diagrama 3)

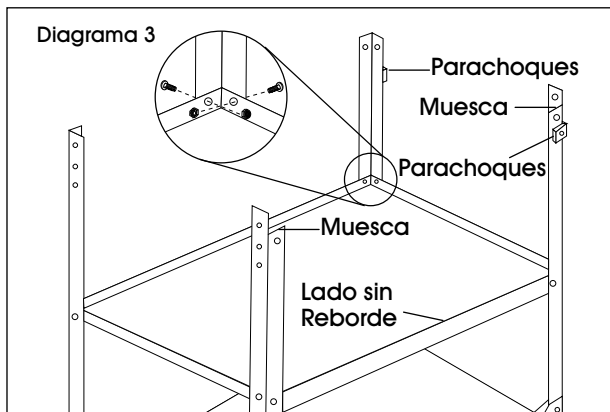

4. Fije el asa a los soportes sin parachoques con pernos medianos de cruz y contratuercas. Los brazos del asa que los pernos atraviesan deben estar dentro de los soportes. (Vea Diagrama 4)

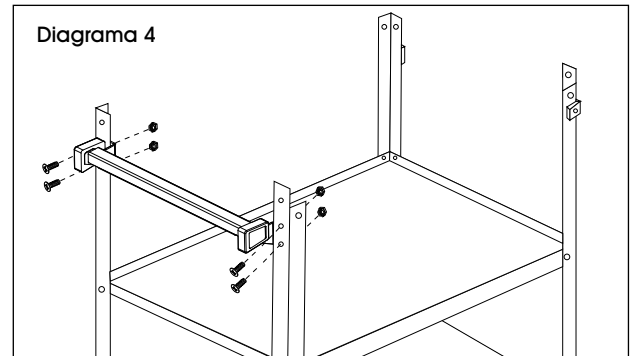

5. Fije la repisa superior a los soportes con pernos chicos de cruz y contratuercas. Asegúrese de que el lado de la repisa superior sin reborde esté en el mismo lado de los soportes con muesca. Ajuste todos los pernos por completo. (Vea Diagrama 5).

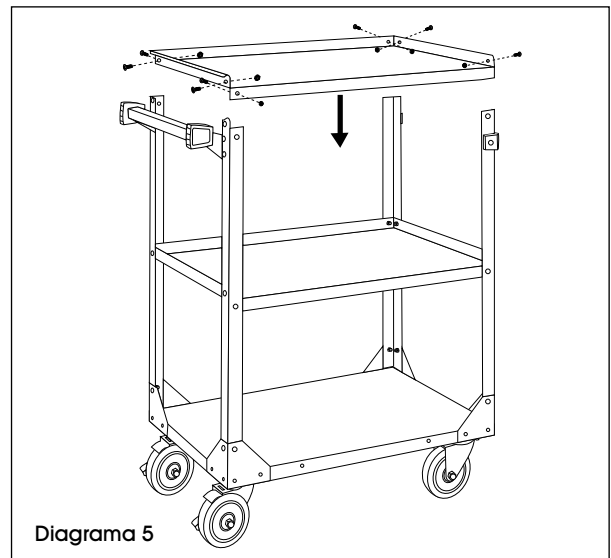

ULINE

800-295-5510
uline.mx

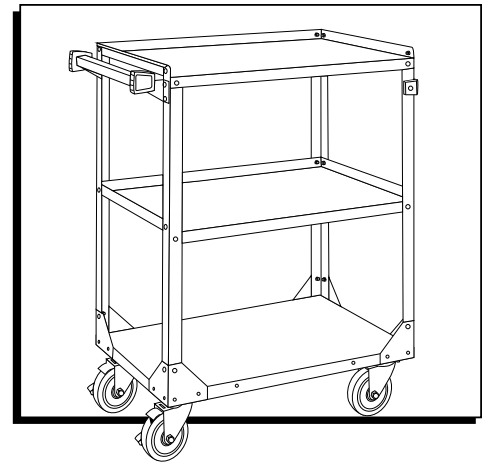
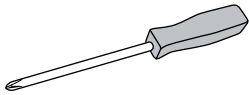
**OUTILS REQUIS**

Tournevis cruciforme

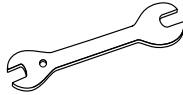

Clé de 8 mm

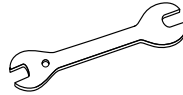

Clé de 1/2 po

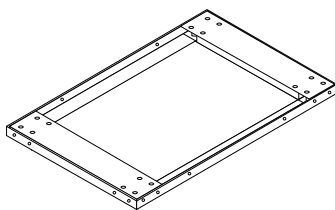
PIÈCES

Tablette inférieure x 1

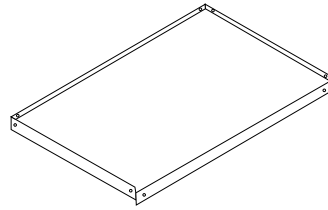

Tablette centrale x 1

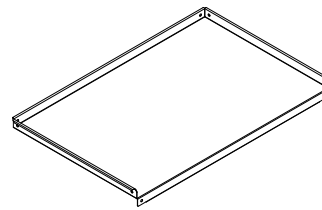

Tablette supérieure x 1

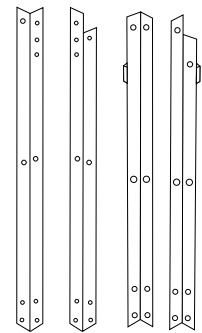

Support x 4

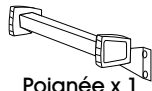

Poignée x 1

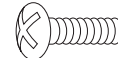
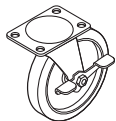
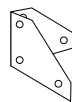
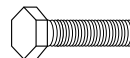
Petit boulon
cruciforme x 24Boulon moyen
cruciforme x 4
(pour poignée)Grand boulon
cruciforme x 16Roulette pivotante
avec frein x 2Roulette pivotante
x 2Plaque de
tablette inférieure
x 4Boulon
hexagonal
x 16Écrou de
blocage x 28Rondelle de
blocage x 16Rondelle plate
x 16**MONTAGE**

- Fixez les roulettes à la tablette inférieure à l'aide de boulons hexagonaux, de rondelles de blocage et de rondelles plates. Ne serrez pas complètement. (Voir Figure 1)



REMARQUE : Assurez-vous que les deux roulettes pivotantes avec frein sont sur le même côté du chariot et que les roulettes pivotantes sont à l'opposé.

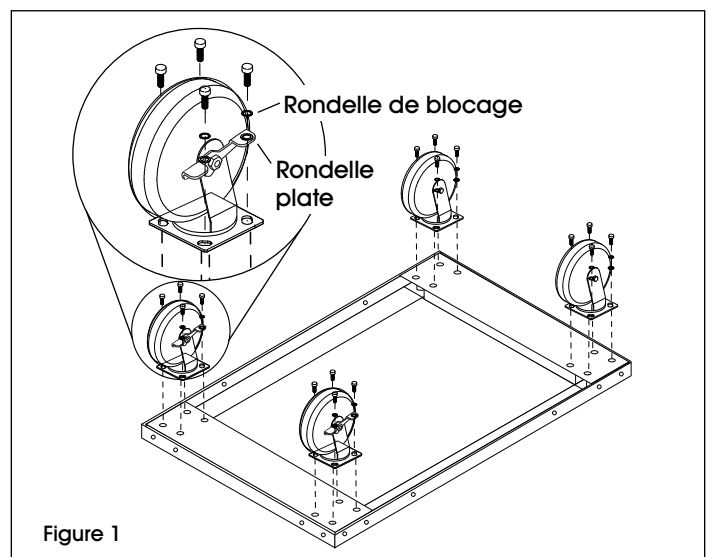

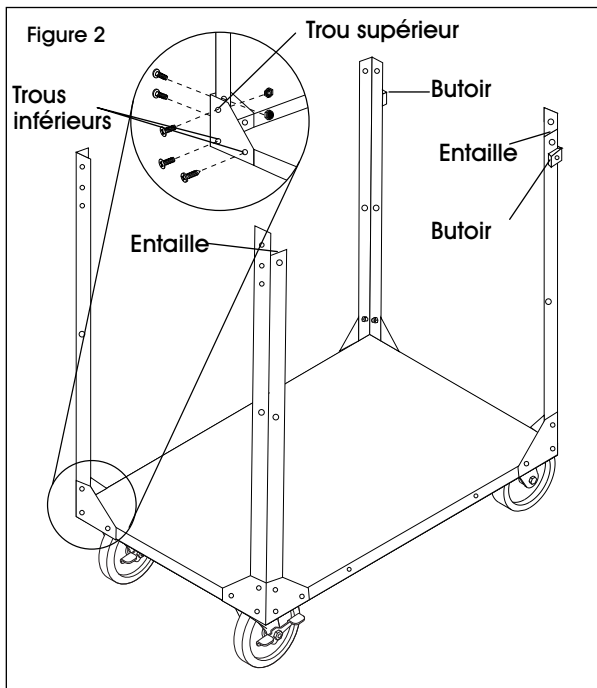

Figure 1

MONTAGE SUITE

2. Insérez les grands boulons cruciformes à travers les trous inférieurs de la plaque de tablette inférieure. Enfilez à travers les supports et dans les parties filetées de la tablette inférieure. Insérez ensuite les boulons petits cruciformes à travers le trou supérieur de la plaque de tablette inférieure et les supports. Fixez le tout avec les écrous de blocage. (Voir Figure 2)

 **REMARQUE :** Assurez-vous que les deux supports avec une entaille sur le haut sont face à face sur les côtés opposés. Les supports avec le butoir en caoutchouc doivent être aussi du même côté.



3. Fixez la tablette centrale aux supports à l'aide de boulons petits cruciformes et d'écrous de blocage. Assurez-vous que le côté sans rebord de la tablette est du même côté que les supports avec une entaille. (Voir Figure 3)

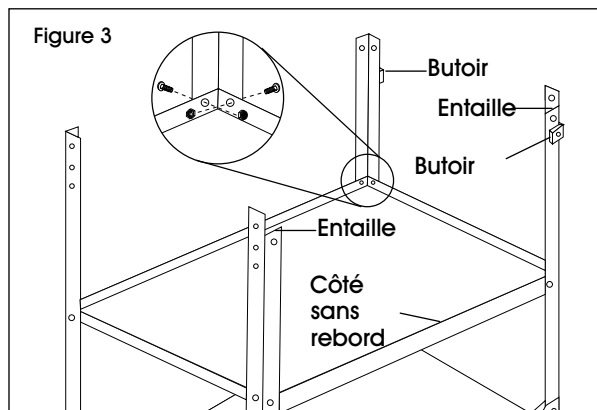

4. Fixez la poignée aux supports sans butoirs à l'aide de moyens boulons cruciformes et d'écrous de blocage. Les supports de la poignée destinés aux boulons doivent se trouver à l'intérieur des autres supports. (Voir Figure 4)

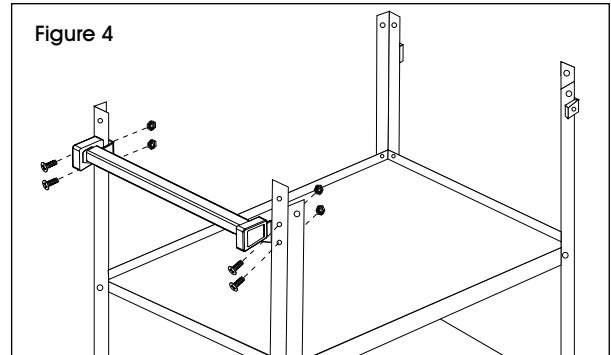

5. Fixez la tablette supérieure aux supports à l'aide de boulons petits cruciformes et d'écrous de blocage. Assurez-vous que le côté sans rebord de la tablette supérieure est du même côté que les supports avec une entaille. Vissez complètement tous les boulons. (Voir Figure 5)

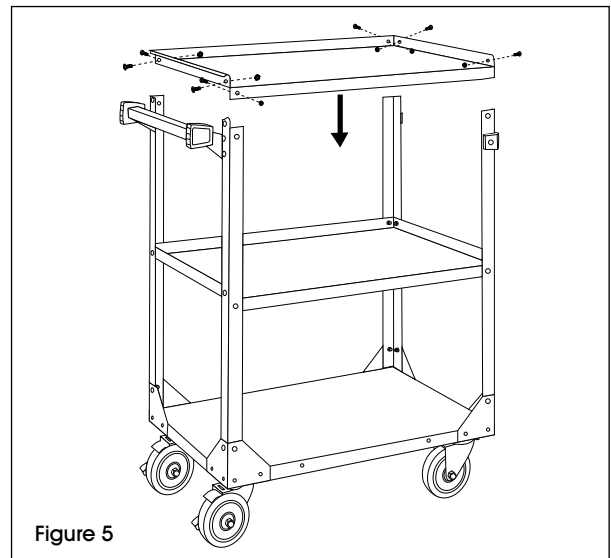

ULINE

1-800-295-5510
uline.ca