

ULINE H-7550 ECONOMY AV CART WITH TRAY

1-800-295-5510
uline.com

Para Español, vea páginas 4-6.
Pour le français, consulter les pages 7-9.



TOOLS NEEDED

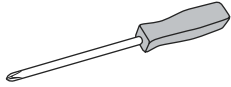

Phillips Screwdriver



Rubber Mallet



10 mm
Wrench



5/32"
Allen Wrench

PARTS

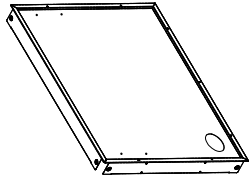

Top Shelf x 1

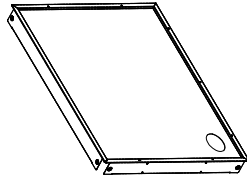

Middle Shelf x 1

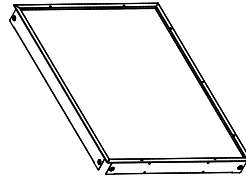

Bottom Shelf x 1



Bottom Post x 4



Top Post x 4

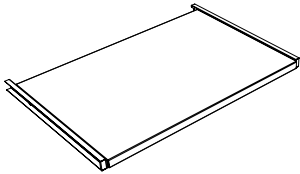

Keyboard Tray x 1

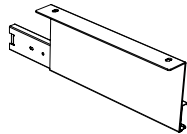

Left Tray Bracket x 1

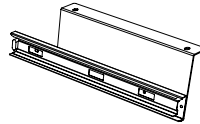

Right Tray Bracket x 1

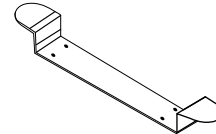

Cord Wrap Bracket x 1

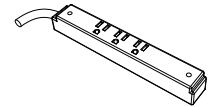

Power Strip x 1

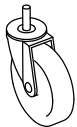

Swivel Caster x 2



Swivel Caster
with Brake x 2



Washer x 24



Nut x 28



Small Keps Nut for
Keyboard Tray Bracket x 4

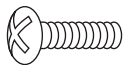

Large Phillips Head
Bolt for Keyboard
Tray Bracket x 4

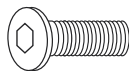

Short Hex Bolt x 24

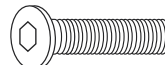

Long Hex Bolt x 4



Self-tapping
Screw x 4

ASSEMBLY

1. Place middle shelf upside down on flat surface. Attach bottom posts to middle shelf using short hex bolts, nuts and washers. Secure with 5/32" allen wrench and 10mm wrench. The end of the post with more holes should be attached to middle shelf. (See Figure 1)

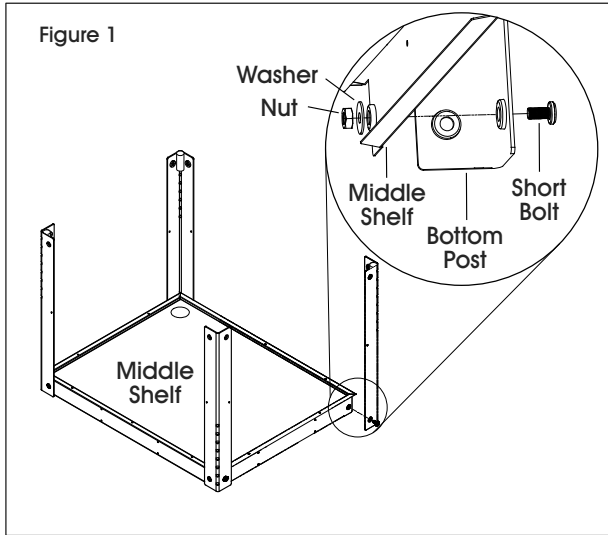

3. Insert casters into caster inserts in bottom posts. Tap in with a rubber mallet. (See Figure 3)



NOTE: Ensure swivel casters are both on same side of cart and swivel with brake casters are on other side.

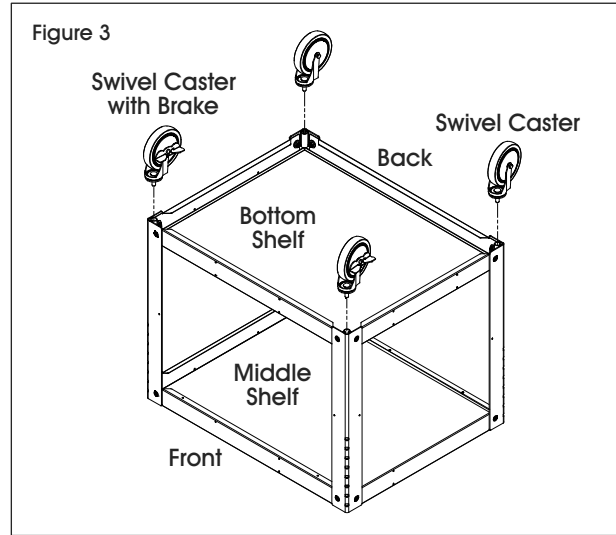

2. Place bottom shelf upside down and attach to bottom posts using short hex bolts, nuts and washers. (See Figure 2)

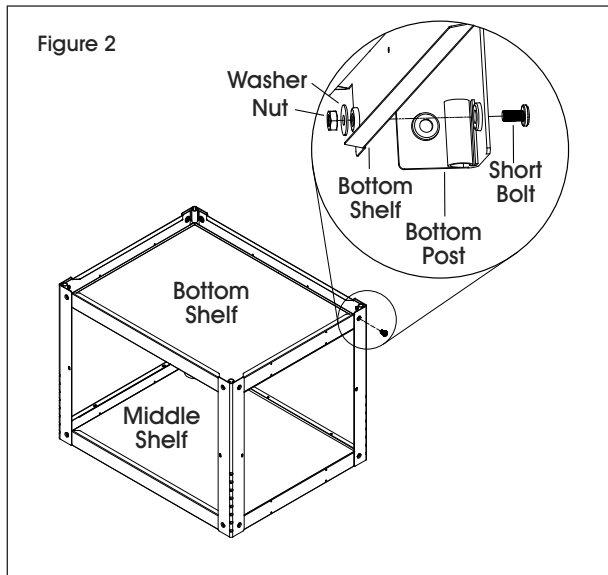

4. Place top shelf upside down on flat surface. Attach top posts to top shelf using short hex bolts, nuts and washers. The end of the post with less holes should be attached to top shelf. (See Figure 4)

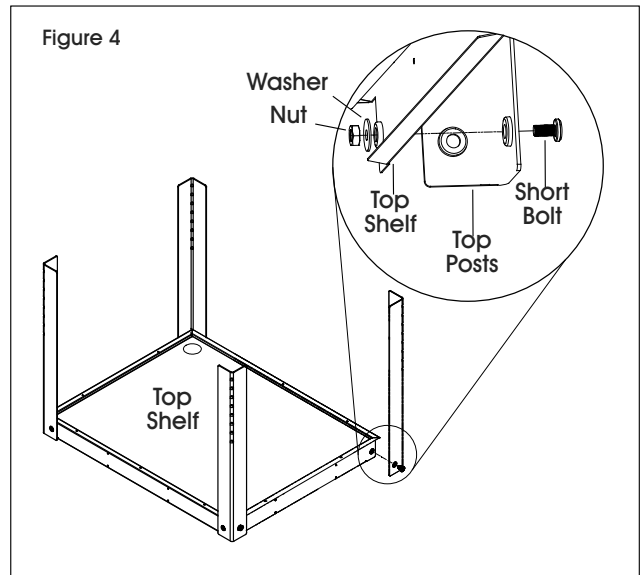

ASSEMBLY CONTINUED

5. Attach top shelf and top posts to bottom half of cart using long hex bolts and nuts. Make sure large hole in top corner of shelf lines up with hole in middle shelf. Cart height can be adjusted by moving long hex bolts and nuts to different desired levels. (See Figure 5)

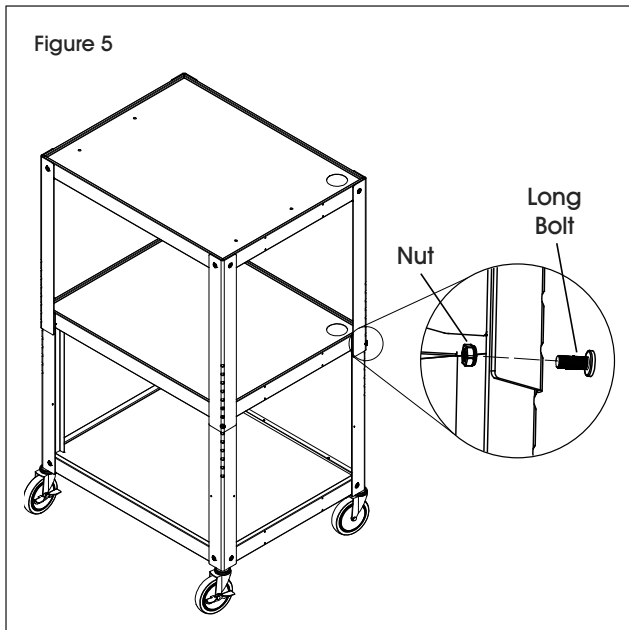

7. Align keyboard tray brackets with tray slides. Locate tabs on sides of keyboard tray. At the same time, pull down on tab on left side of keyboard tray and push up on tab on right side of keyboard tray. While doing this, carefully push keyboard tray into tray slides until fully inserted. (See Figure 7)

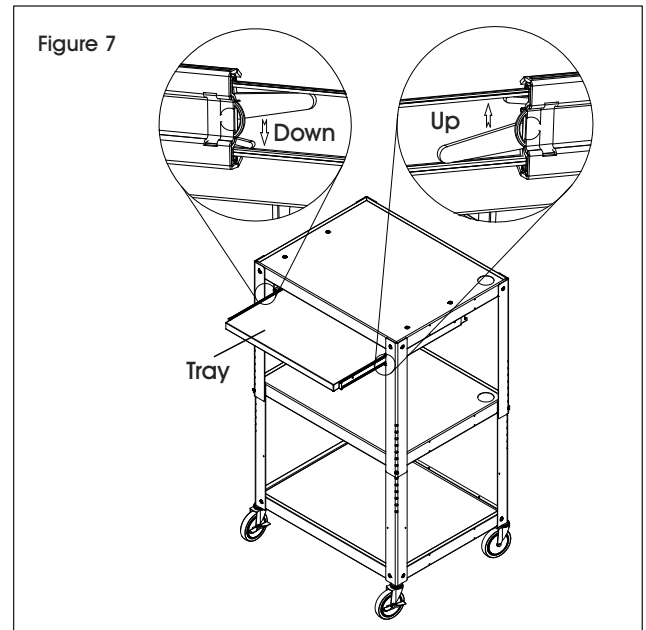

6. Attach left and right tray brackets to top shelf using large phillips head bolts and small keps nuts. (See Figure 6)

 **NOTE:** Ensure that tray brackets are facing in towards middle of cart and tray slides pull out towards front of cart.

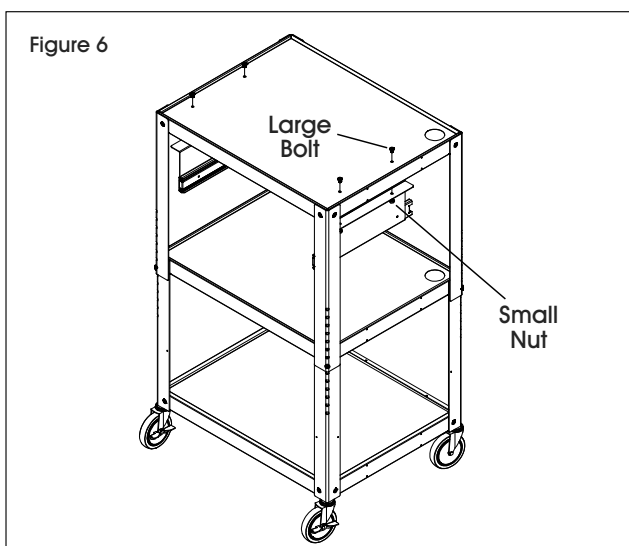

8. Attach cord wrap bracket and power strip to top shelf using self-tapping screws. (See Figure 8)

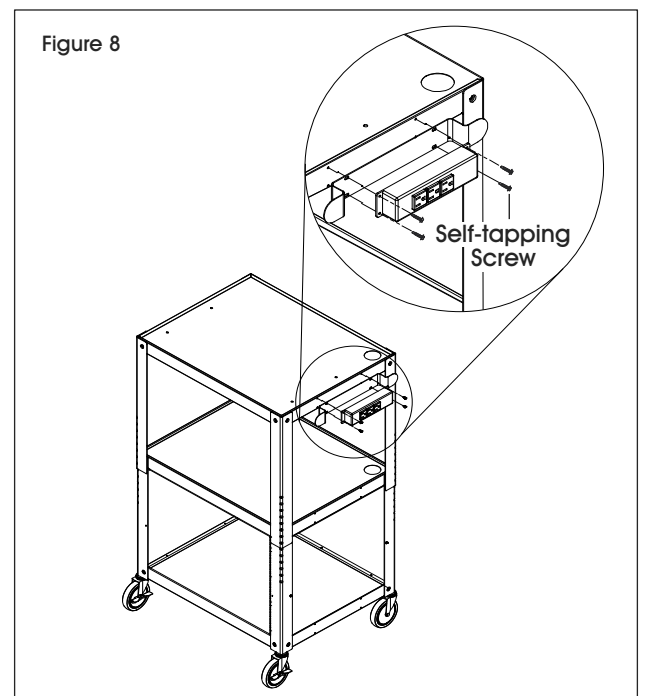

9. Ensure all nuts, bolts and screws are fully tightened.

ULINE

1-800-295-5510

uline.com

ULINE H-7550

CARRITO ECONÓMICO PARA AUDIOVISUALES CON BANDEJA

800-295-5510
uline.mx



HERRAMIENTAS NECESARIAS

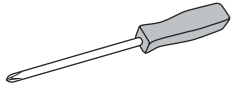

Desarmador de Cruz



Mazo de Caucho



Llave de 10 mm



Llave Allen de 5/32"

PARTES

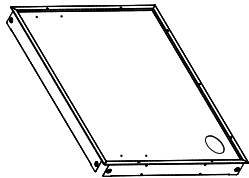

1 Repisa Superior

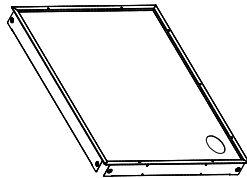

1 Repisa Intermedia

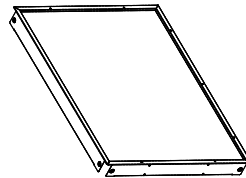

1 Repisa Inferior



4 Postes Traseros



4 Postes Superiores

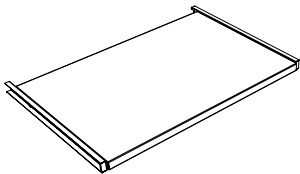

1 Bandeja para Teclado

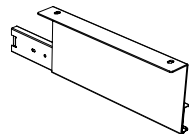

1 Soporte Izquierdo para Bandeja

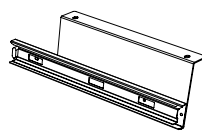

1 Soporte Derecho para Bandeja

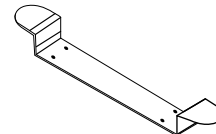

1 Soporte para Envoltura de Cable

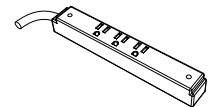

1 Extensión Eléctrica

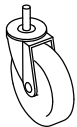

2 Ruedas Giratorias



2 Ruedas Giratorias con Freno



24 Rondanas



28 Tuercas



4 Tuercas Keps Chicas para Soportes de Bandeja para Teclado

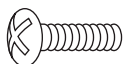

4 Pernos Grandes de Cruz para Soportes de Bandeja para Teclado

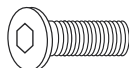

24 Pernos Hexagonales Cortos

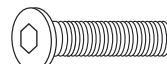

4 Pernos Hexagonales Largos



4 Tornillos Autorroscantes

ENSAMBLE

1. Coloque el gabinete inferior boca abajo sobre una superficie plana. Fije los postes inferiores a la repisa intermedia usando pernos hexagonales cortos, tuercas y rondanas. Asegúrelos con una llave Allen de 5/32" y llave de 10mm. El extremo del poste con la mayor cantidad de orificios se debe fijar a la repisa intermedia. (Vea Diagrama 1)

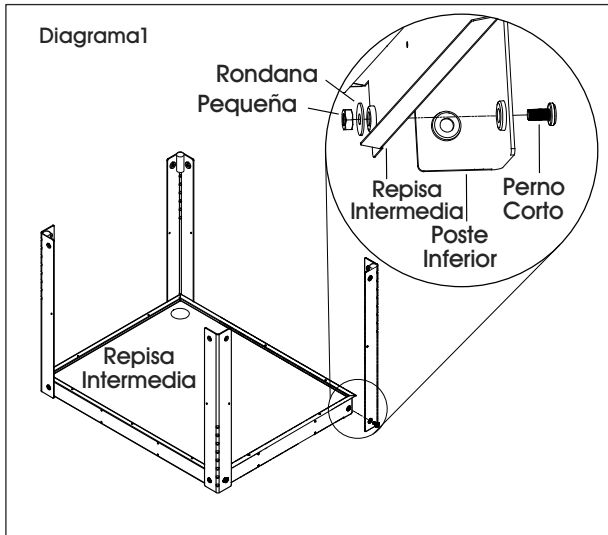

3. Introduzca las ruedas dentro de los insertos correspondientes de los postes inferiores. Fíjelas con un mazo de caucho. (Vea Diagrama 3)

NOTA: Asegúrese de que las ruedas giratorias estén en el mismo lado del carrito y las ruedas giratorias con freno estén en el otro lado.

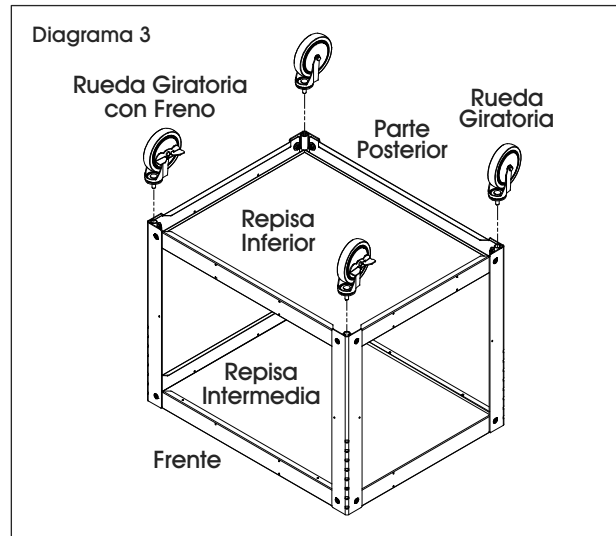

2. Coloque la repisa inferior boca abajo y fíjela a los postes inferiores con pernos hexagonales cortos, tuercas y rondanas. (Vea Diagrama 2)

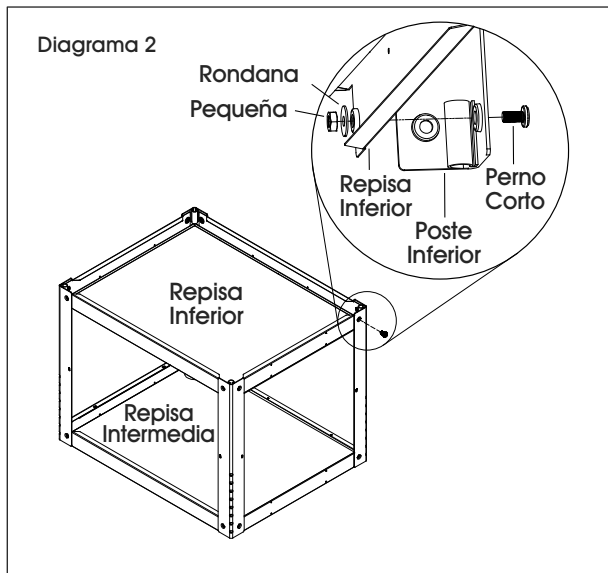

4. Coloque la repisa superior boca abajo sobre una superficie plana. Fije los postes superiores a la repisa intermedia usando pernos hexagonales cortos, tuercas y rondanas. El extremo del poste con la menor cantidad de orificios se debe fijar a la repisa superior. (Vea Diagrama 4)

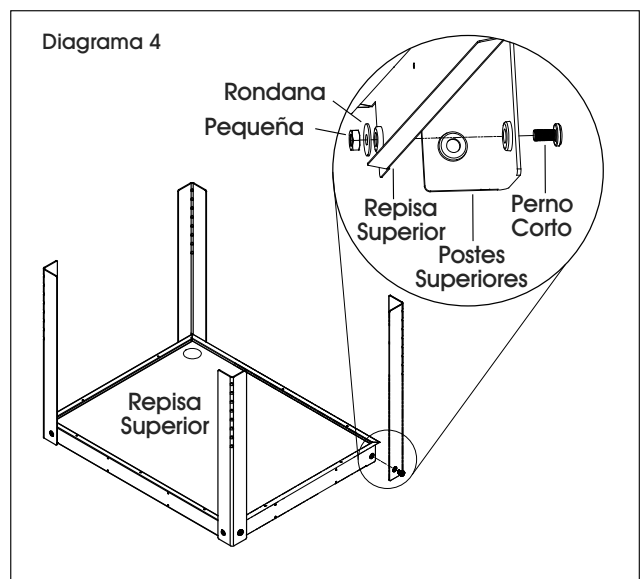

CONTINUACIÓN DEL ENSAMBLE

5. Fije la repisa superior y los postes superiores a la mitad inferior del carrito usando los pernos hexagonales largo y tuercas. Asegúrese de que el orificio grande en la esquina superior de la repisa quede alineado con el orificio en la repisa intermedia. La altura del carrito se puede ajustar moviendo los pernos hexagonales largos y tuercas a diferentes niveles deseados. (Vea Diagrama 5)

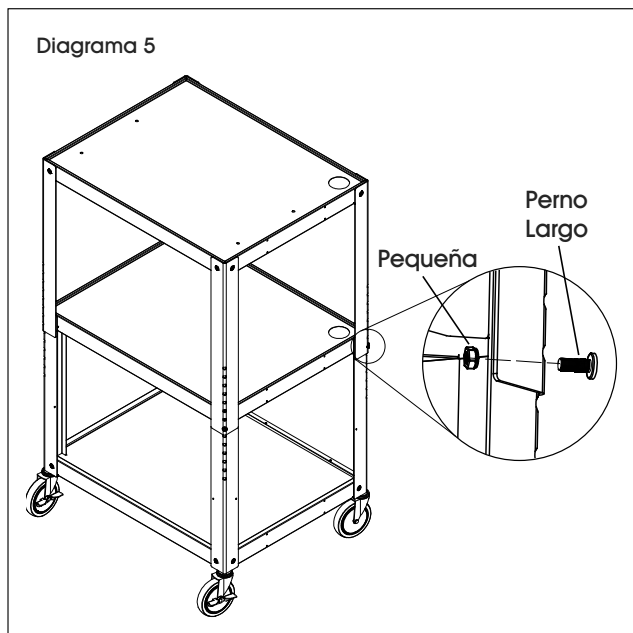

6. Fije los soportes para bandeja izquierdo y derecho a la repisa superior utilizando pernos grandes de cruz y tuercas keps pequeñas. (Vea Diagrama 6)

 **NOTA:** Asegúrese de que los soportes para bandeja estén orientados hacia el centro del carro y las correderas para bandeja salgan hacia el frente del carrito.

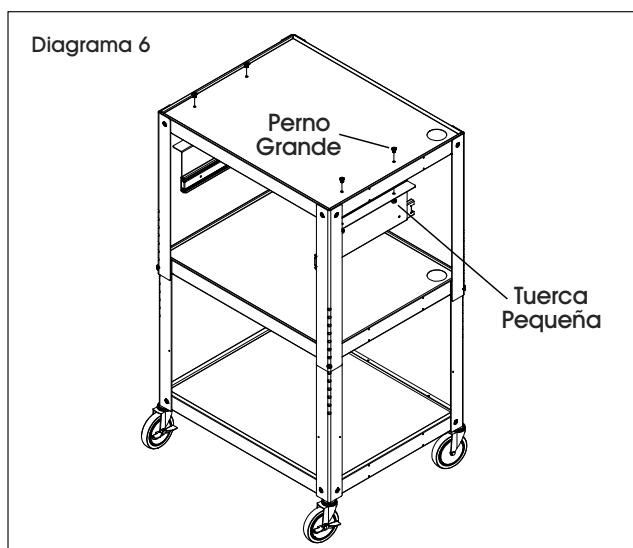

7. Alinee los soportes para bandeja para teclado con las correderas para bandeja. Localice las pestañas en los lados de la bandeja para teclado. Al mismo tiempo, tire la pestaña en el lado izquierdo de la bandeja para teclado hacia abajo y empuje la pestaña en el lado derecho de la bandeja para teclado hacia arriba. Al hacer esto, empuje con cuidado la bandeja para teclado en las correderas para bandeja hasta que quede insertada por completo. (Vea Diagrama 7)

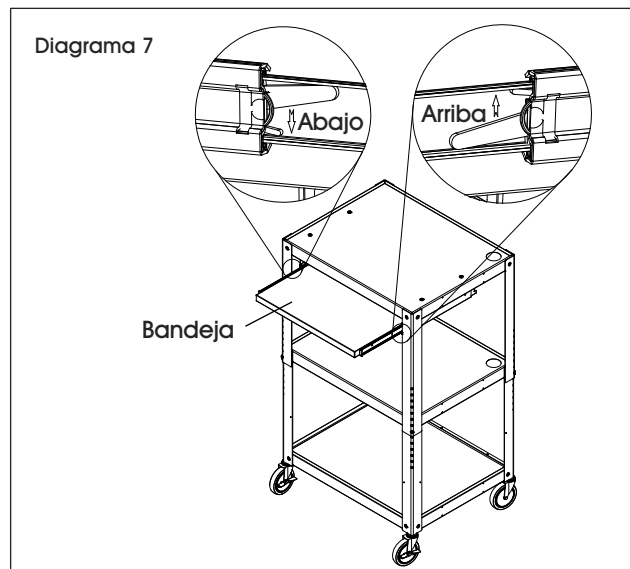

8. Fije el soporte para envoltura de cable y la extensión eléctrica a la repisa superior usando los tornillos autorroscantes. (Vea Diagrama 8)

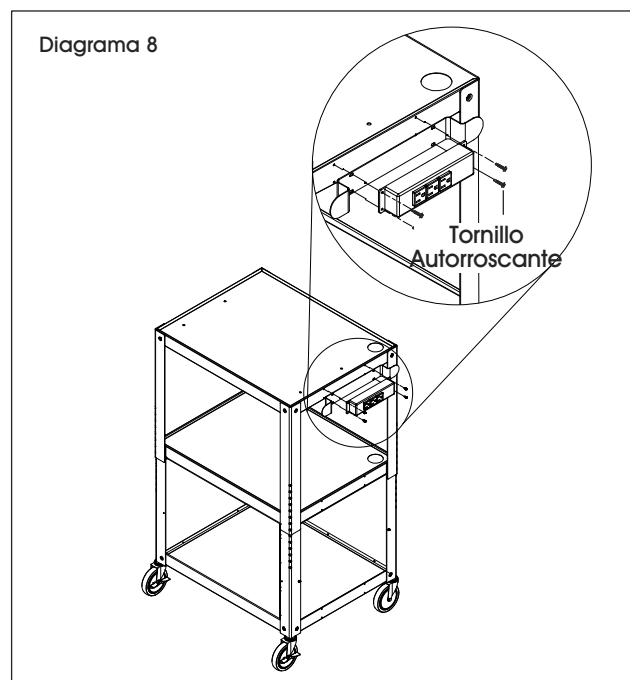

9. Asegúrese de que todas las tuercas, pernos y tornillos estén ajustados por completo.

ULINE

800-295-5510
uline.mx

ULINE H-7550

CHARIOT AUDIOVISUEL ÉCONOMIQUE AVEC PLATEAU

1-800-295-5510

uline.ca



OUTILS REQUIS

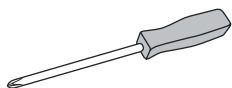

Tournevis cruciforme



Maillet en caoutchouc



Clé de 10 mm



Clé Allen de 5/32 po

PIÈCES

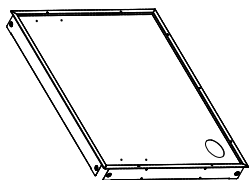

Tablette supérieure x 1

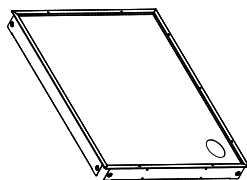

Tablette centrale x 1

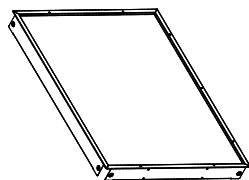

Tablette inférieure x 1



Montant inférieur x 4



Montant supérieur x 4

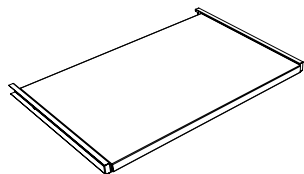

Plateau pour clavier x 1

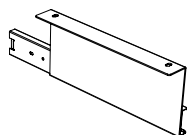

Support de plateau gauche x 1

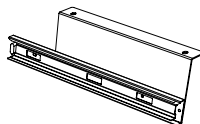

Support de plateau droit x 1

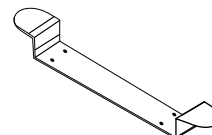

Support pour enroulement du cordon x 1

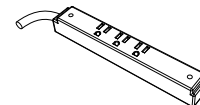

Barre multiprise x 1

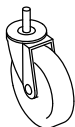

Roulette pivotante x 2

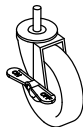

Roulette pivotante avec frein x 2



Rondelle x 24



Écrou x 28



Petit écrou à taquets pour support de plateau pour clavier x 4



Grand boulon à tête cruciforme pour support de plateau pour clavier x 4

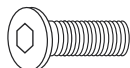

Boulon court hexagonal x 24

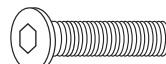

Boulon long hexagonal x 4



Vis autotaraudeuse x 4

MONTAGE

1. Placez la tablette centrale à l'envers sur une surface plane. Fixez les montants inférieurs à la tablette centrale à l'aide des boulons courts hexagonaux, des écrous et des rondelles. Fixez le tout avec la clé Allen de 5/32 po et la clé de 10 mm. L'extrémité du montant comprenant plus de trous doit être fixée à la tablette centrale. (Voir Figure 1)

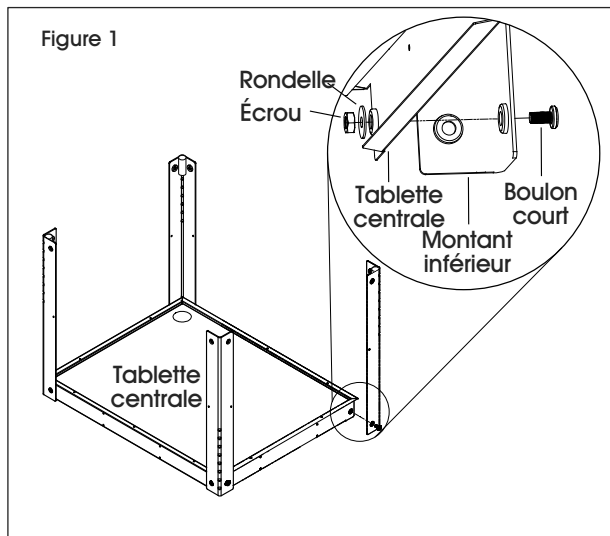

2. Placez la tablette inférieure à l'envers et fixez-la sur les montants inférieurs à l'aide des boulons courts hexagonaux, des écrous et des rondelles. (Voir Figure 2)

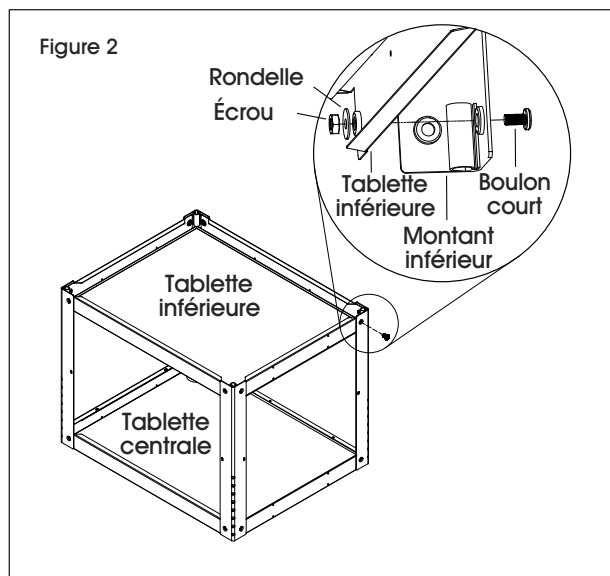

3. Insérez les roulettes dans les orifices se trouvant dans les montants inférieurs. Enfoncez-les en vous servant du maillet en caoutchouc. (Voir Figure 3)

REMARQUE : Assurez-vous que les roulettes pivotantes sont sur le même côté du chariot et que les roulettes avec frein sont à l'opposé.

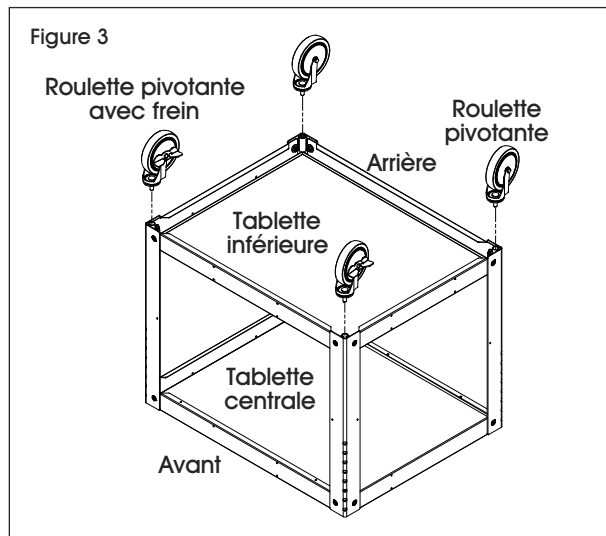

4. Placez la tablette supérieure à l'envers sur une surface plane. Fixez les montants supérieurs à la tablette supérieure à l'aide des boulons courts hexagonaux, des écrous et des rondelles. L'extrémité du montant comprenant moins de trous doit être fixée à la tablette supérieure. (Voir Figure 4)

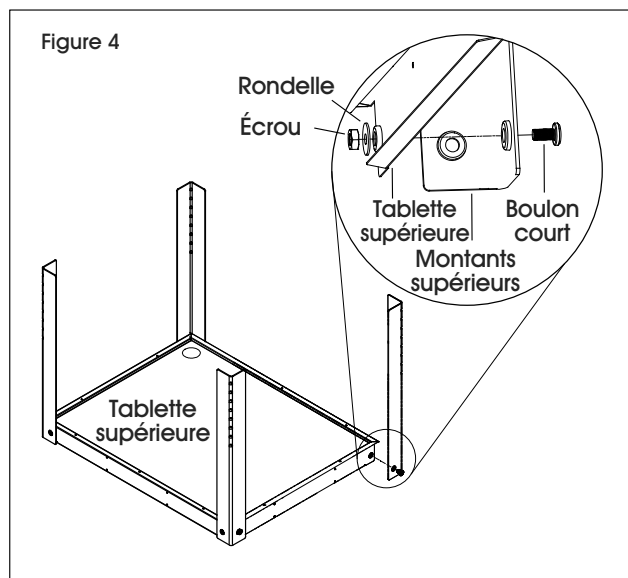

MONTAGE SUITE

5. Fixez la tablette supérieure et les montants supérieurs à la moitié inférieure du chariot à l'aide des boulons longs hexagonaux et des écrous. Assurez-vous que le large trou dans le coin de la tablette supérieure est aligné sur le trou de la tablette centrale. La hauteur du chariot peut être réglée en déplaçant les longs boulons hexagonaux et les écrous sur des niveaux différents. (Voir Figure 5)

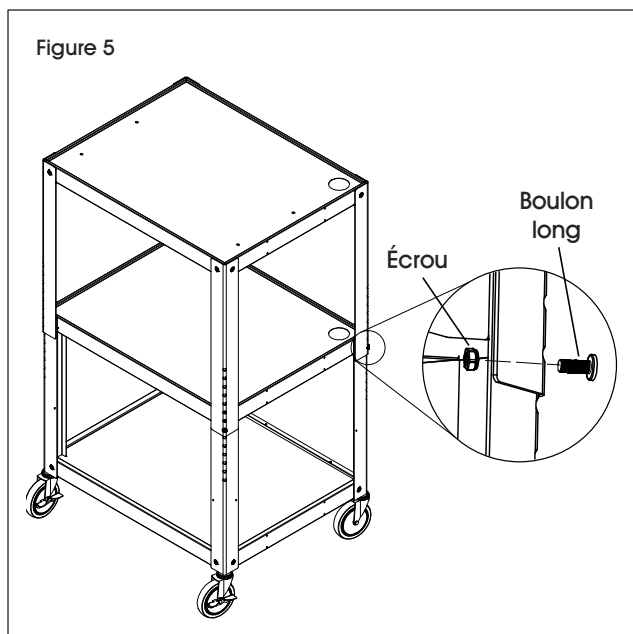

6. Fixez les supports de plateau gauche et droit à la tablette supérieure à l'aide des grands boulons à tête cruciforme et des petits écrous à taquets. (Voir Figure 6)

REMARQUE : Assurez-vous que les supports de plateau sont orientés vers l'intérieur du chariot et que les coulisses glissent vers l'avant.

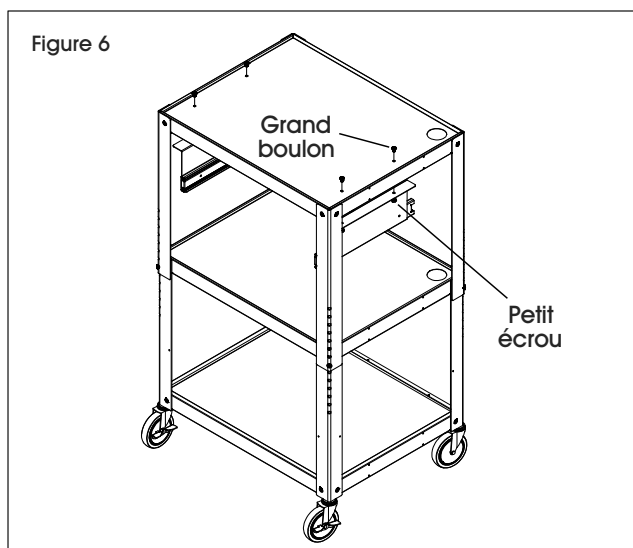

7. Alignez les supports de plateau pour clavier sur les coulisses de plateau. Repérez les onglets situés sur les côtés du plateau pour clavier. Poussez simultanément vers le bas l'onglet sur le côté gauche du plateau pour clavier et vers le haut l'onglet sur le côté droit. Au même moment, poussez doucement le plateau pour clavier dans les coulisses jusqu'à ce qu'il soit complètement inséré. (Voir Figure 7)

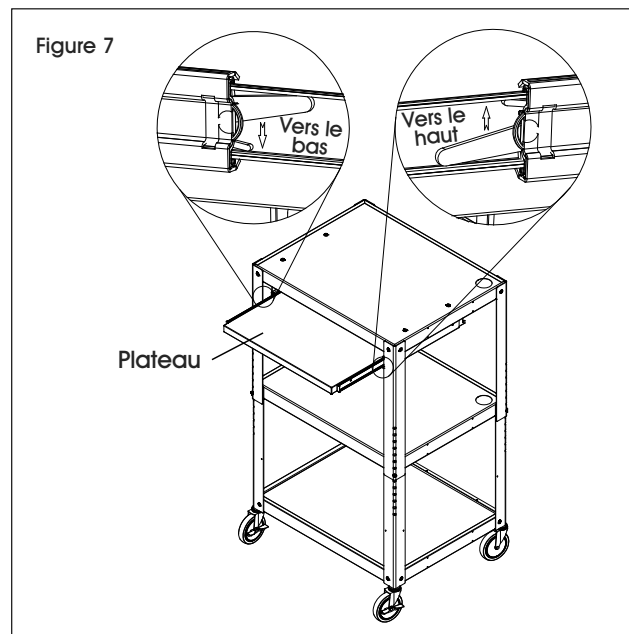

8. Fixez le support pour enroulement du cordon et la barre multiprise à la tablette supérieure à l'aide des vis autotaraudeuses. (Voir Figure 8)

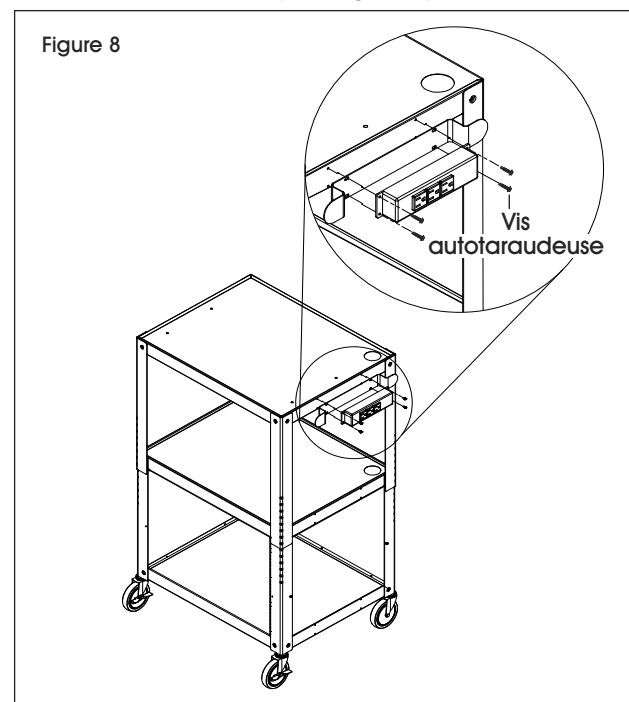

9. Assurez-vous que tous les boulons, écrous et vis sont bien serrés.