

ULINE H-7699 MOBILE SHOP DESK

1-800-295-5510
 uline.com

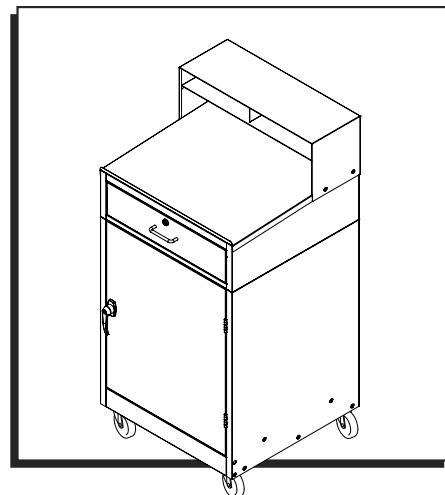

TOOLS NEEDED

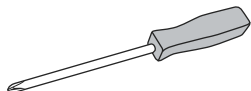

Phillips Screwdriver

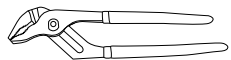

Channel Lock Pliers



8 mm Wrench
 10 mm Wrench
 17 mm Wrench

PARTS

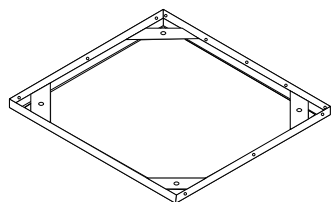

Base x 1

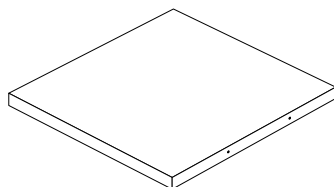

Bottom Shelf x 1

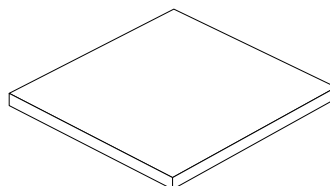

Middle Shelf x 1

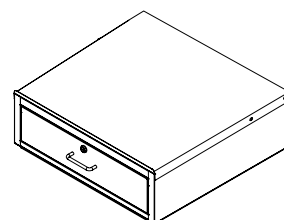

Desk Top and Drawer x 1

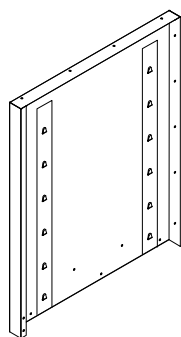

Side Panel x 2

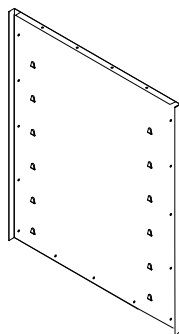

Back Panel x 1

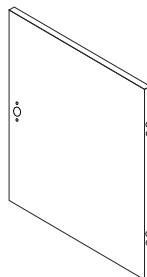

Door x 1

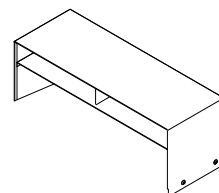

Top Shelf x 1

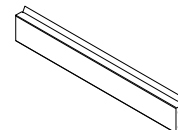

Front Channel x 1

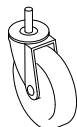

Caster x 4

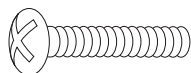

M6 x 35 Phillips
 Head Bolt x 4

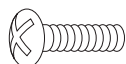

M6 x 12 Phillips
 Head Bolt x 4

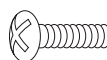

M5 x 8 Phillips
 Head Bolt x 4



Hex Nut x 4



Flange Nut x 44

DOOR HANDLE ASSEMBLY HARDWARE

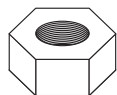

Large Hex Nut x 1



Lock Washer x 1



M5 x 5 Phillips Panhead Bolt x 2



Door Lock x 1



Door Handle x 1

ASSEMBLY

1. Using channel lock pliers, attach casters to threaded inserts underneath base. (See Figure 1)

 **NOTE:** Lock casters for remainder of assembly.

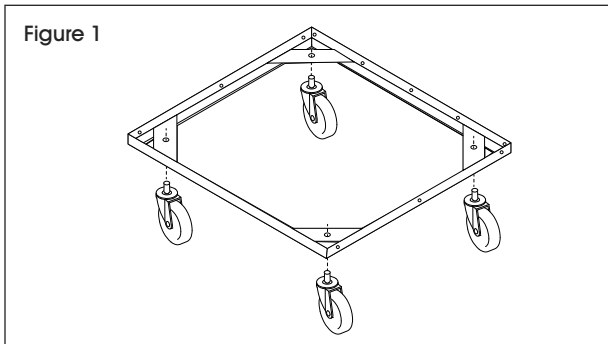

2. Using 10 mm wrench and Phillips screwdriver, install back, left and right side panels to the base with nineteen M6 x 12 Phillips head bolts and flange nuts. (See Figure 2)

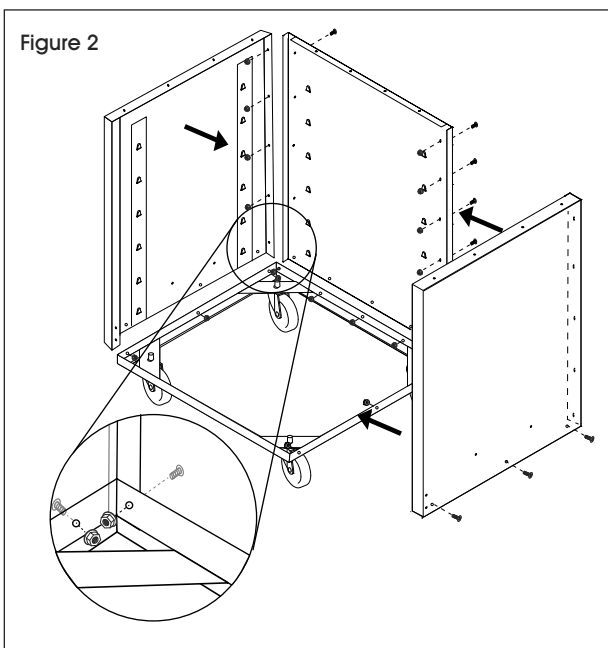

3. Using Phillips screwdriver, attach front channel to side panels with four M6 x 35 Phillips head bolts. (See Figure 3)

 **NOTE:** Threaded inserts are located in the front channel.

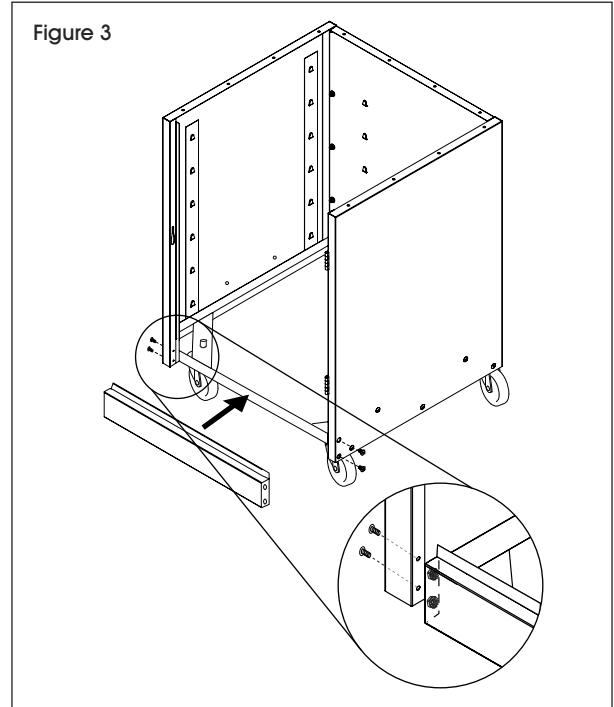

4. Attach front channel to bottom of base with three M6 x 12 Phillips head bolts and flange nuts. (See Figure 4)

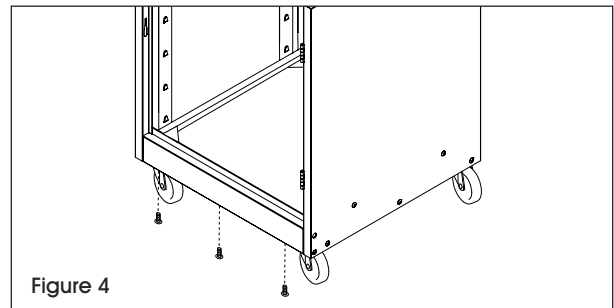

ASSEMBLY CONTINUED

5. Place bottom shelf onto bottom clips attached to side and back panels. Secure to side panels using four M6 x 12 Phillips head bolts and flange nuts. (See Figure 5)

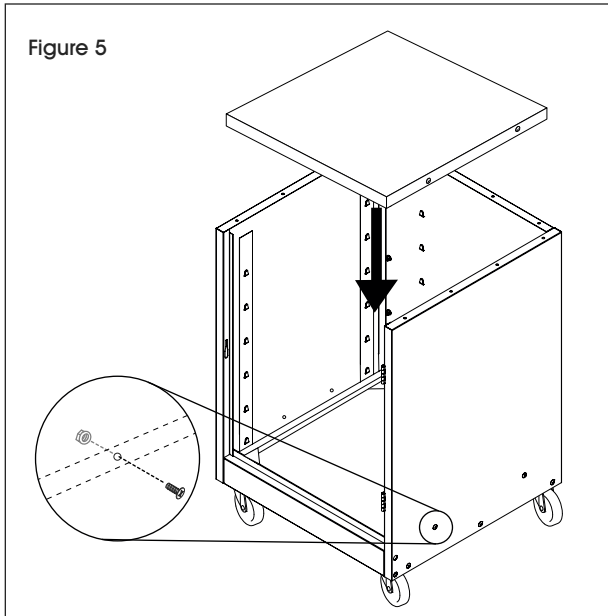

6. Remove drawer from desk top. Flip desk top and place on a smooth, non-marring surface with top side facing down.
7. Place desk frame onto desk top and secure with twelve M6 x 12 Phillips head bolts and flange nuts. (See Figure 6)

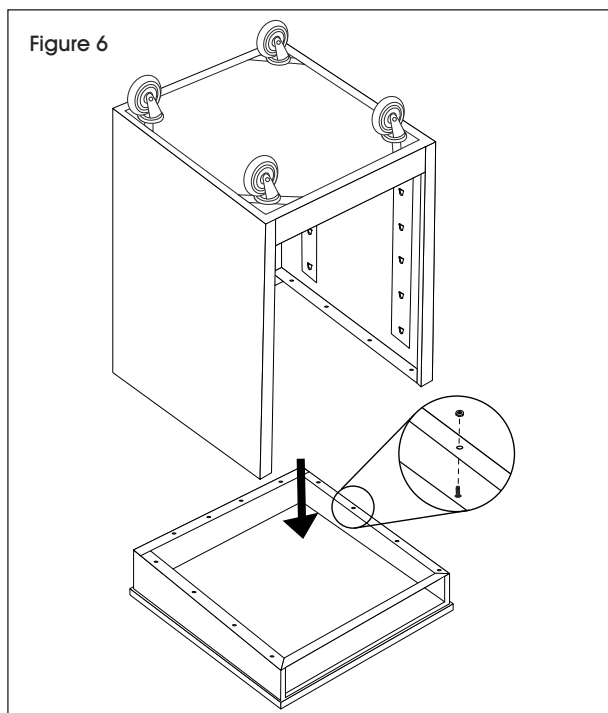

8. Set desk top assembly upright and recheck all bolts and nuts for tightness.
9. Place top shelf onto desk top and secure with six M6 x 12 Phillips head bolts and flange nuts using a 10 mm wrench and Phillips screwdriver. (See Figure 7)

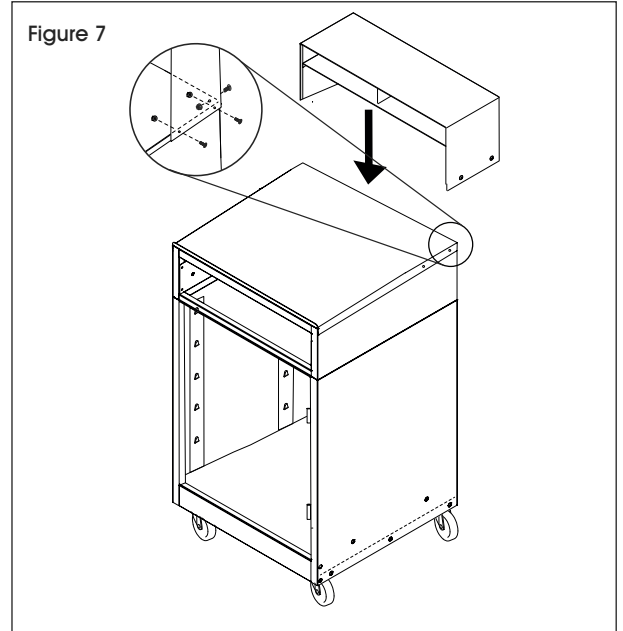

10. Place middle shelf at desired height on shelf clips attached to the inside of the side and back panels. (See Figure 8)

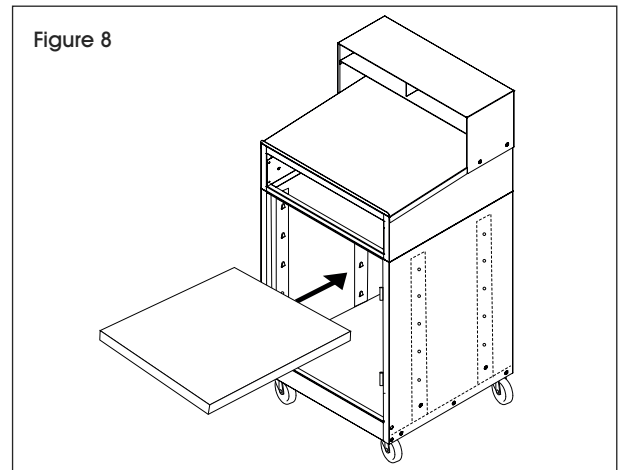

ASSEMBLY CONTINUED

11. Attach door to hinges with four M5 x 8 Phillips head bolts and hex nuts, using an 8 mm wrench and Phillips screwdriver. (See Figure 9)

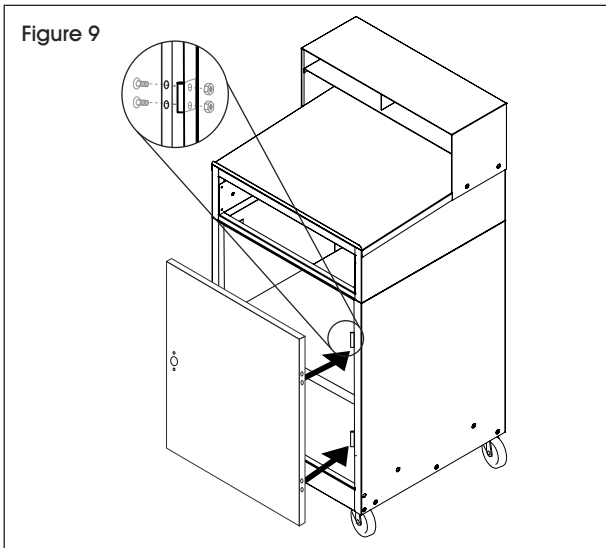

12. Insert door handle into door loosely and thread two M5 x 5 Phillips Panhead bolts into door handle from inside of door. Do not tighten. (See Figure 10)

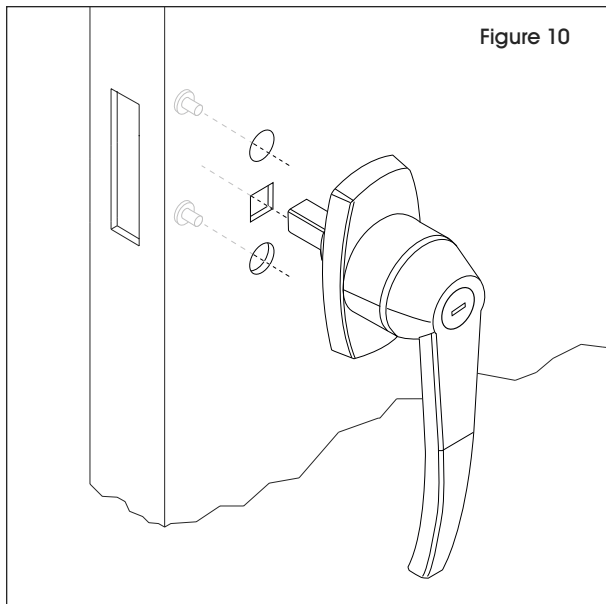

13. On the inside of the door, place door lock through the thread of the door handle and the hole on the side of the door. Secure door handle using the two M5 x 5 Phillips Panhead bolts and Phillips screwdriver. (See Figures 11-12)

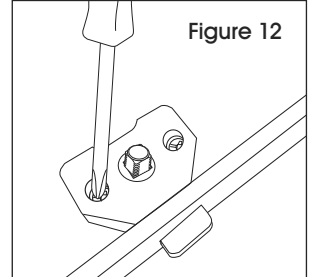
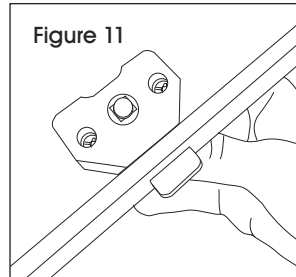

14. Secure door lock by placing lock washer and large hex nut onto door handle thread and fasten using 17 mm wrench. (See Figure 13)

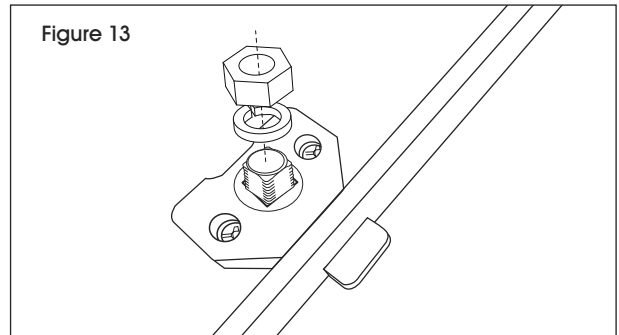

15. Insert drawer. (See Figure 14)

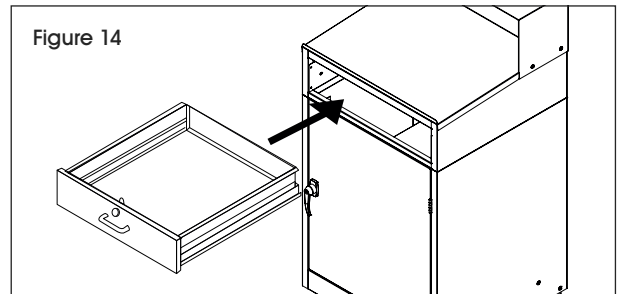

ULINE

1-800-295-5510
uline.com

ULINE H-7699

ESCRITORIO MÓVIL PARA TALLER

800-295-5510
uline.mx

HERRAMIENTAS NECESARIAS

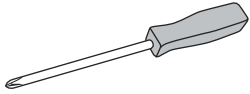

Desarmador de Cruz

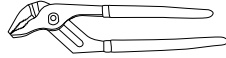

Pinzas de Extensión



Llave de 8 mm
Llave de 10 mm
Llave de 17 mm

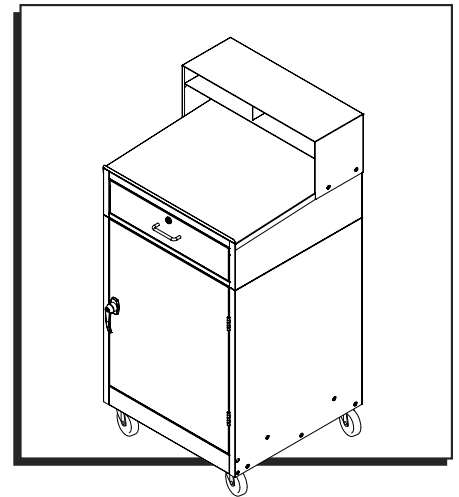

PARTES

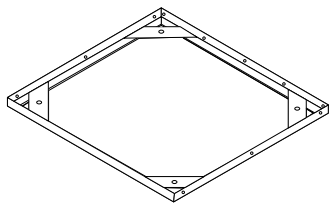

1 Base

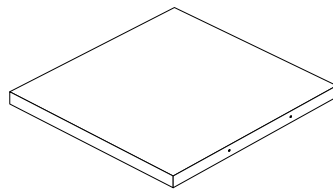

1 Repisa Inferior

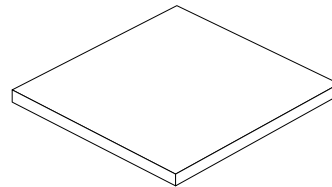

1 Repisa Intermedia

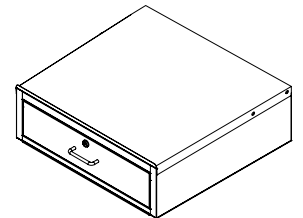

1 Cubierta y Cajón para
Escritorio

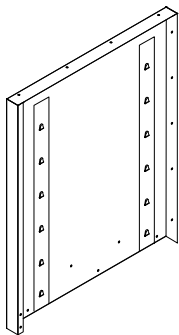

2 Paneles Laterales

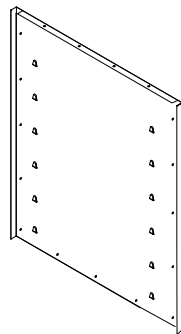

1 Panel Posterior

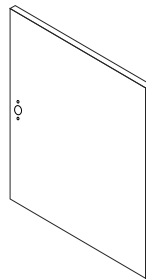

1 Puerta

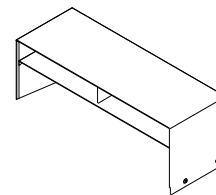

1 Repisa Superior

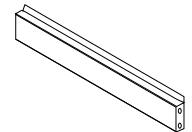

1 Canal Frontal

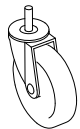

4 Ruedas

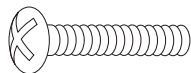

4 Pernos de
Cruz M6 x 35"

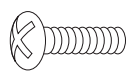

44 Pernos de
Cruz M6 x 12"

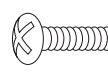

4 Pernos de Cruz
M5 x 8"



4 Pernos
Hexagonales

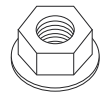

44 Tuercas con
Reborde

TORNILLERÍA PARA ENSAMBLE DEL ASA DE LA PUERTA

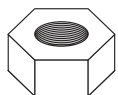

1 Tuerca Hexagonal
Grande



1 Rondana de
Seguridad



2 Pernos de Cabeza
Plana M5 x 5

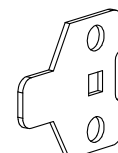

1 Cerradura
de Puerta



1 Asa de
la Puerta

ENSAMBLE

1. Usando las pinzas de extensión, fije las ruedas a los insertos roscados debajo de la base. (Vea Diagrama 1)

 **NOTA:** Bloquee las ruedas durante el resto del ensamble.

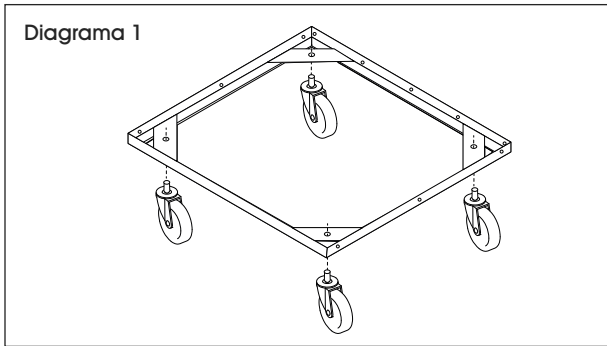

2. Usando la llave de 10 mm y el desarmador de cruz, instale los paneles posterior, izquierdo y derecho a la base con diecinueve pernos de cruz M6 x 12 y tuercas con reborde. (Vea Diagrama 2)

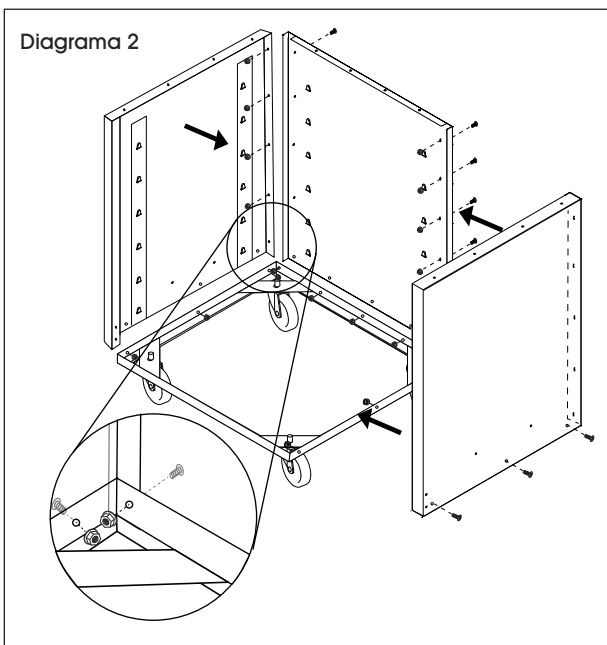

3. Usando el desarmador de cruz, fije el canal frontal a los paneles laterales con cuatro pernos de cruz M6 x 35. (Vea Diagrama 3)

 **NOTA:** Los insertos roscados se ubican en el canal frontal.

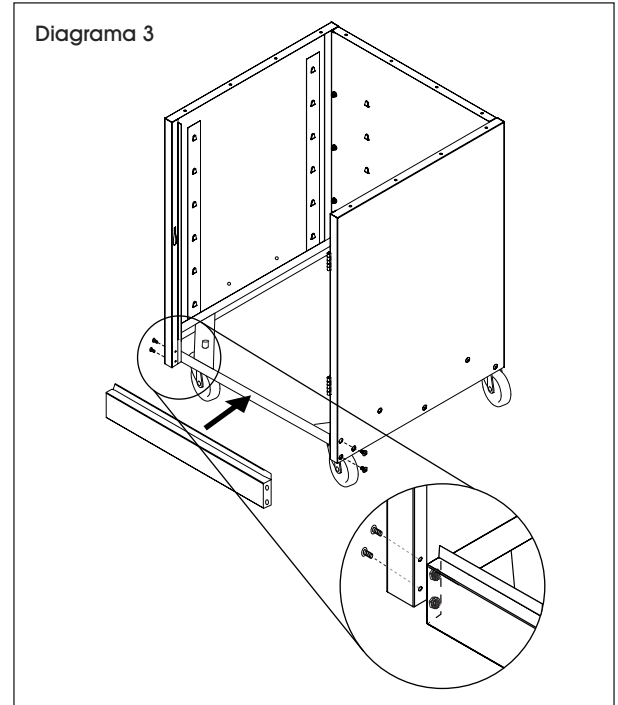

4. Fije el canal frontal a la parte inferior de la base con tres pernos de cruz M6 x 12 y tuercas con reborde. (Vea Diagrama 4)

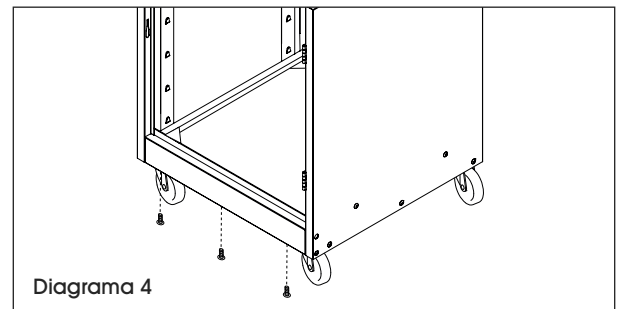

CONTINUACIÓN DEL ENSAMBLE

5. Coloque la repisa inferior encima de los clips inferiores fijados a los paneles laterales y posterior. Asegúrela a los paneles laterales usando cuatro pernos de cruz M6 x 12 y tuercas con rebordes. (Vea Diagrama 5)

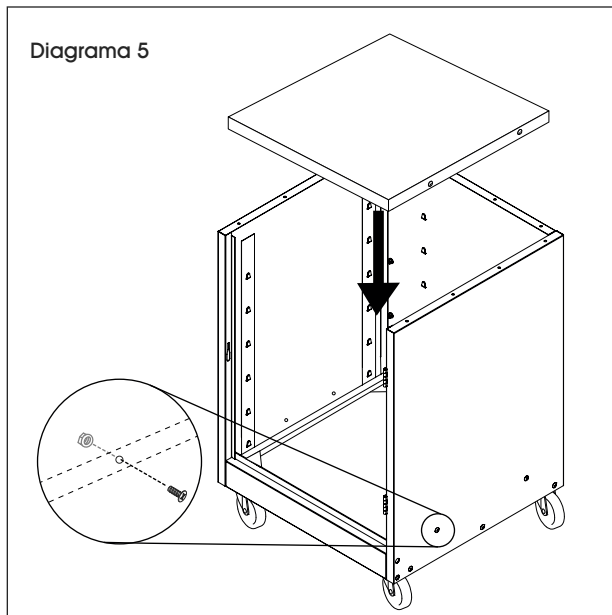

6. Retire el cajón de la cubierta del escritorio. Voltee la cubierta y colóquela sobre una superficie lisa que no deje marcas con el lado superior hacia abajo.
7. Coloque el armazón del escritorio sobre la cubierta del escritorio con doce pernos de cruz M6 x 12 y tuercas con reborde. (Vea Diagrama 6)

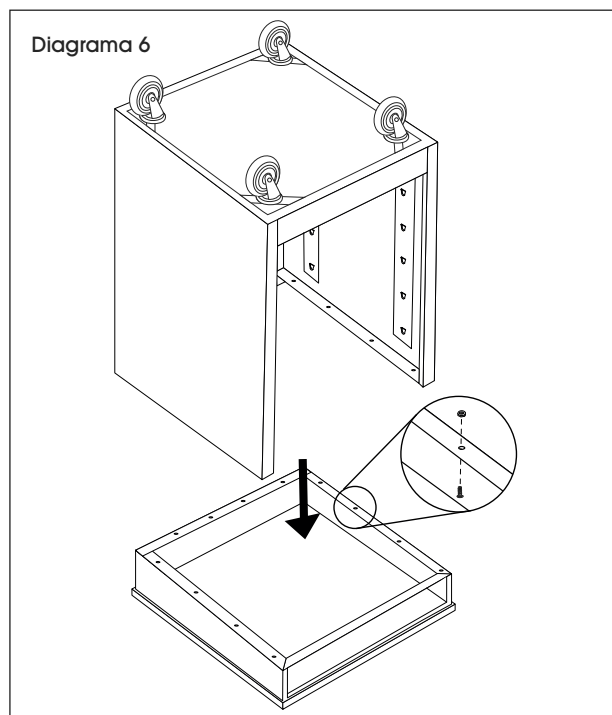

8. Enderece el ensamble del escritorio y verifique nuevamente que todos los tornillos y tuercas estén apretados.
9. Coloque la repisa superior sobre la cubierta del escritorio y fijela con seis pernos de cruz M6 x 12 y tuercas de reborde usando una llave de 10 mm y un desarmador de cruz. (Vea Diagrama 7)

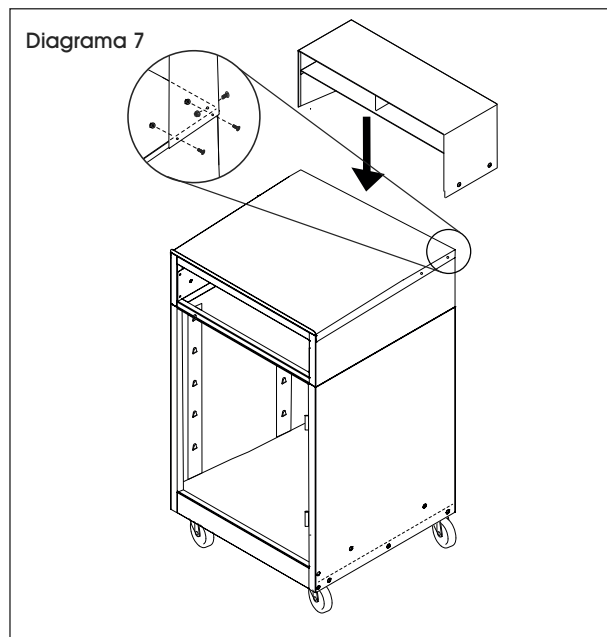

10. Coloque la repisa intermedia a la altura deseada sobre los clips para repisas fijados al interior de los paneles laterales y posterior. (Vea Diagrama 8)

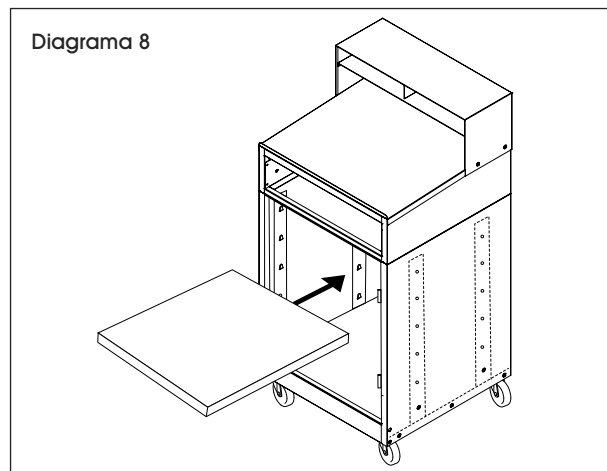

CONTINUACIÓN DEL ENSAMBLE

11. Fije la puerta a las bisagras con cuatro pernos de cruz M5 x 8 y pernos hexagonales usando una llave de 8 mm y un desarmador de cruz. (Vea Diagrama 9)

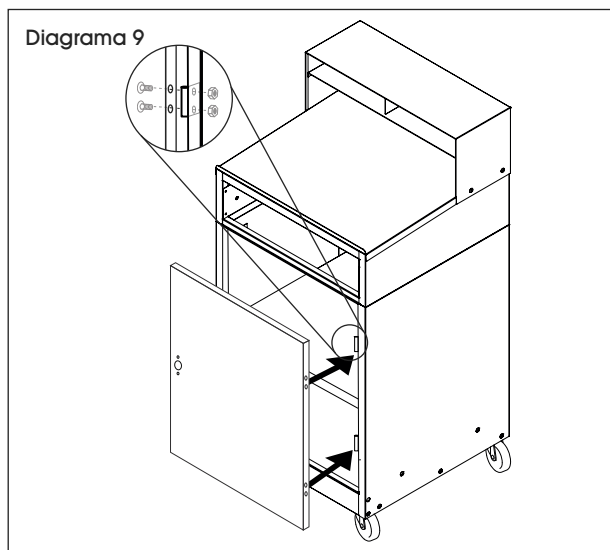

12. Inserte el asa de la puerta en la puerta sin apretar y enrosque dos pernos de cabeza plana M5 x 5 en el asa por dentro de la puerta. No los apriete. (Vea Diagrama 10)

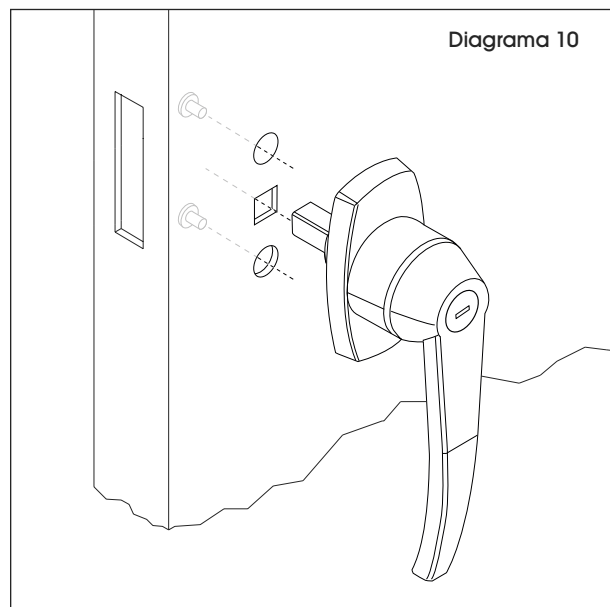

13. En la parte de adentro de la puerta, coloque el seguro de la puerta a través de la parte roscada del asa y el orificio en el lado de la puerta. Asegure el asa de la puerta usando los dos pernos de cabeza plana y el desarmador de cruz. (Vea Diagramas 11-12)

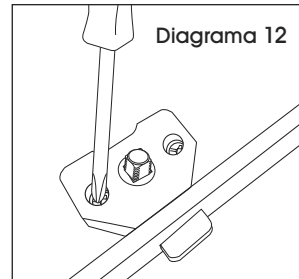
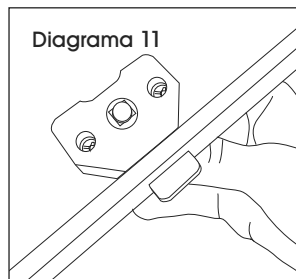

14. Asegure la cerradura de la puerta colocando la rondana de seguridad y la tuerca hexagonal grande, y apriételo usando una llave de 17 mm (Vea Diagrama 13)

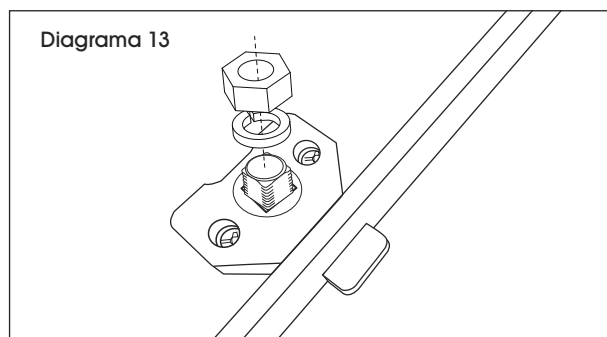

15. Inserte el cajón. (Vea Diagrama 14)

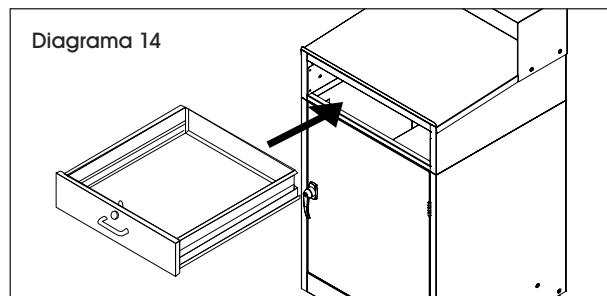

ULINE

800-295-5510
uline.mx

ULINE H-7699

BUREAU D'ATELIER MOBILE

1-800-295-5510
uline.ca

OUTILS REQUIS

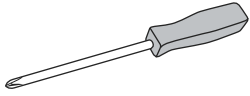

Tournevis cruciforme

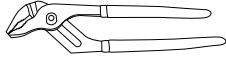

Pince multiprise à crémaillère

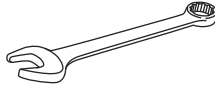

Clé de 8 mm
Clé de 10 mm
Clé de 17 mm

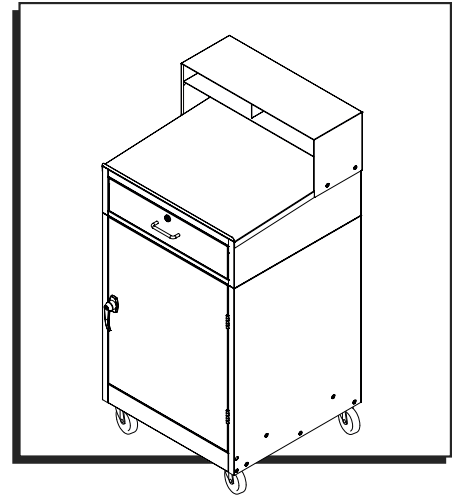

PIÈCES

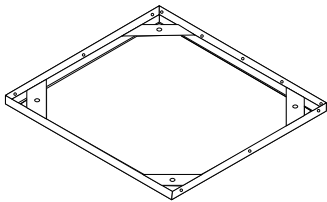

Base x 1

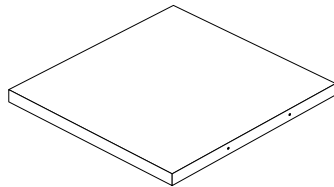

Tablette inférieure x 1

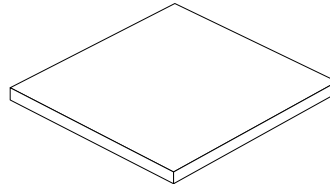

Tablette centrale x 1

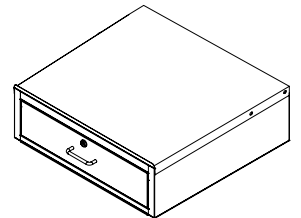

Surface de travail et tiroir x 1

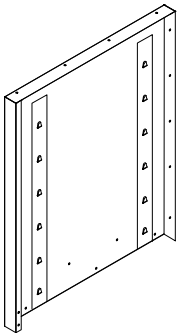

Panneau latéral x 2

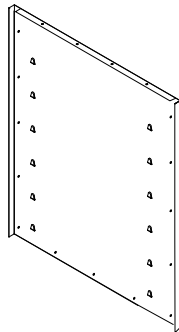

Panneau arrière x 1

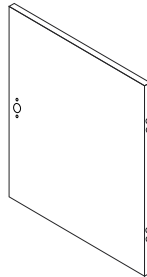

Porte x 1

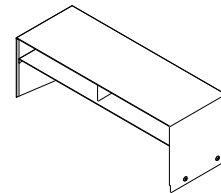

Tablette supérieure x 1

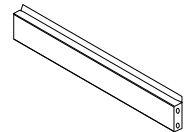

Profilé avant x 1

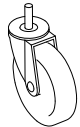

Roulette x 4

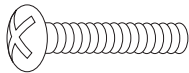

Boulon cruciforme
M6 x 35 x 4

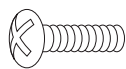

Boulon cruciforme
M6 x 12 x 44

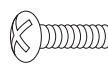

Boulon cruciforme
M5 x 8 x 4



Écrou hexagonal x 4



Écrou à embase x 44

MATÉRIEL D'INSTALLATION DE LA POIGNÉE DE PORTE

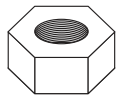

Grand écrou hexagonal x 1



Rondelle de blocage x 1



Boulon cruciforme à tête cylindrique bombée M5 x 5 x 2

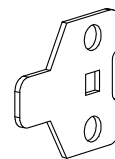

Serrure de porte x 1

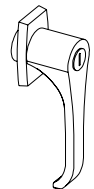

Poignée de porte x 1

MONTAGE

1. Fixez les roulettes aux parties filetées situées en dessous de la base en vous servant de la pince multiprise à crémaillère. (Voir Figure 1)

 **REMARQUE :** Bloquez les roulettes pour le reste du montage.

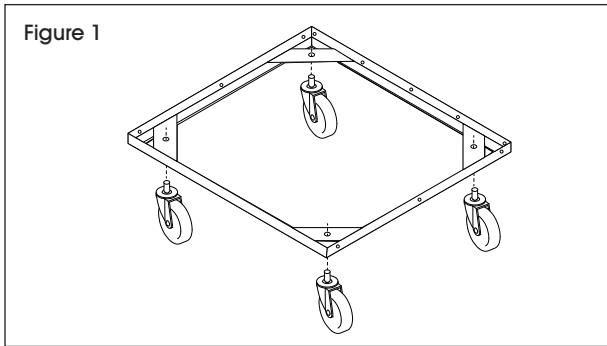

2. Installez les panneaux arrière, latéraux gauche et droit à la base à l'aide de dix-neuf boulons cruciformes M6 x 12 et écrous à embase en vous servant de la clé de 10 mm. (Voir Figure 2)

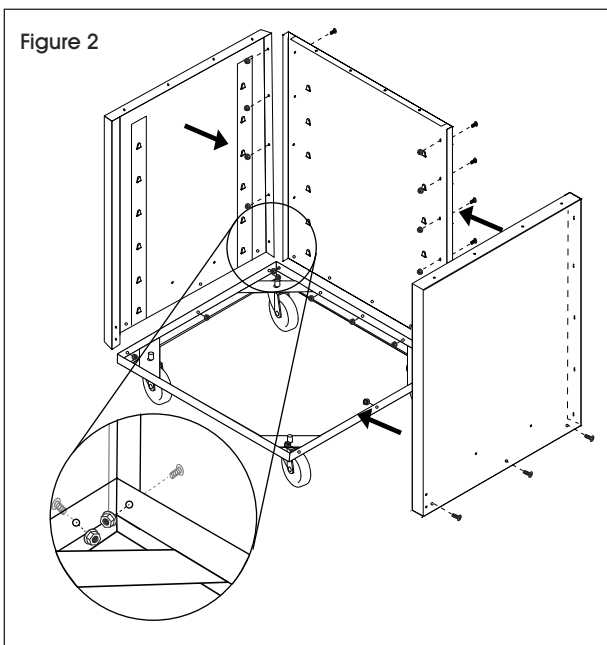

3. Fixez le profilé avant aux panneaux latéraux à l'aide de quatre boulons cruciformes M6 x 35 en vous servant du tournevis cruciforme. (Voir Figure 3)

 **REMARQUE :** Les parties filetées se trouvent dans le profilé avant.

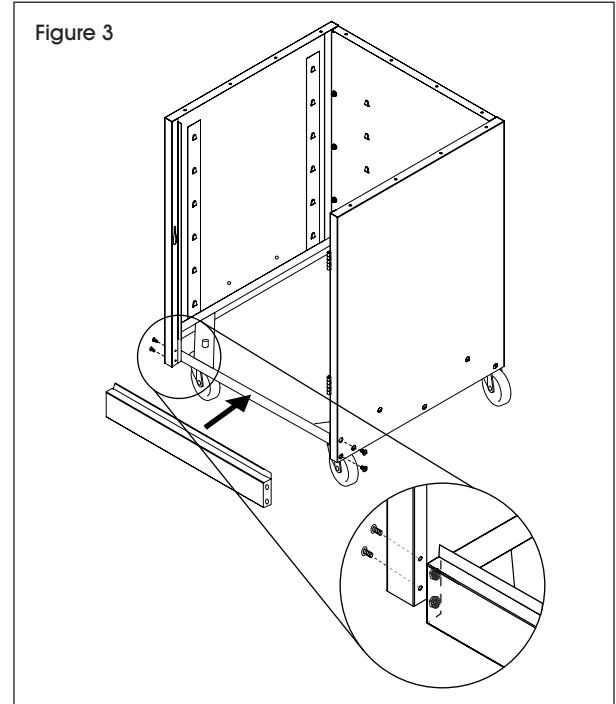

4. Fixez le profilé avant au bas de la base à l'aide de trois boulons cruciformes M6 x 12 et écrous à embase. (Voir Figure 4)

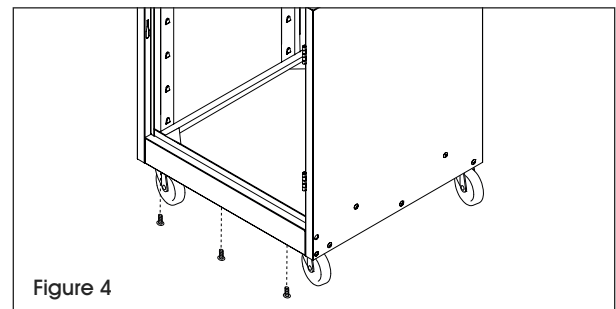

MONTAGE SUITE

5. Placez la tablette inférieure sur les pinces inférieures situées sur les panneaux arrière et latéraux. Fixez-la aux panneaux latéraux à l'aide de quatre boulons cruciformes M6 x 12 et écrous à embase. (Voir Figure 5)

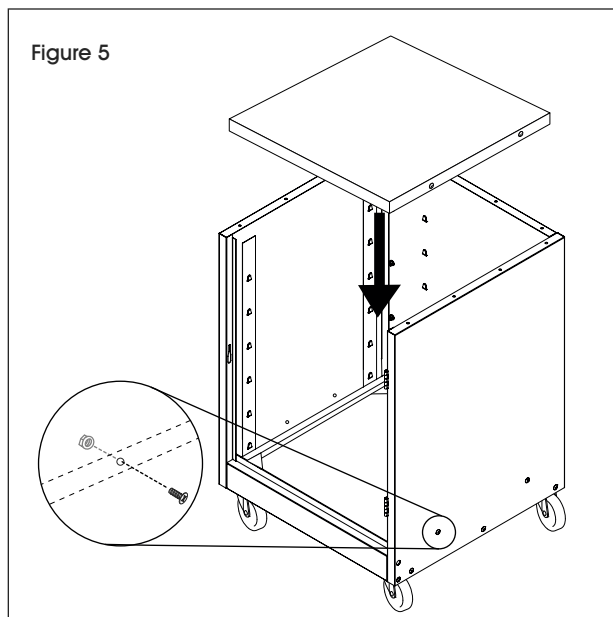

6. Retirez le tiroir de la surface de travail. Retournez et placez la surface de travail sur une surface lisse et non marquante, face vers le bas.
7. Placez la structure du bureau sur la surface de travail et fixez à l'aide de douze boulons cruciformes M6 x 12 et écrous à embase. (Voir Figure 6)

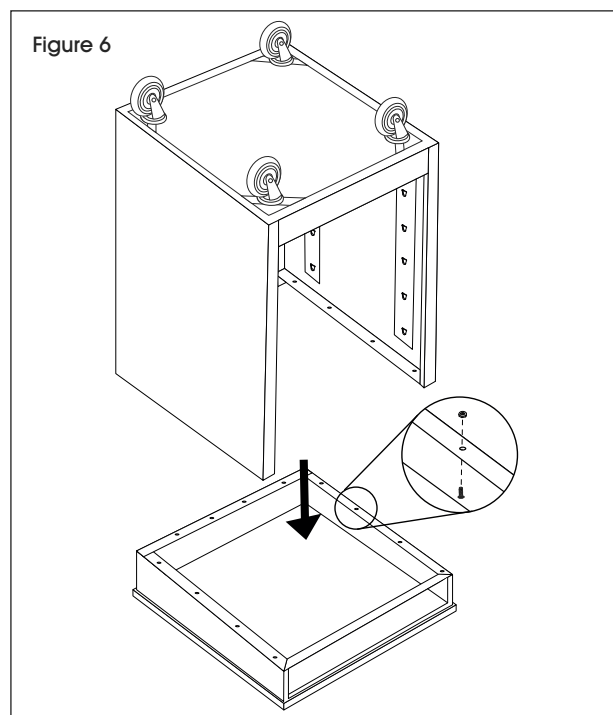

8. Placez la table à l'endroit et vérifiez que tous les boulons et les écrous sont bien serrés.
9. Placez la tablette supérieure sur la surface de travail et fixez à l'aide de six boulons cruciformes M6 x 12 et écrous à embase en vous servant de la clé de 10 mm et du tournevis cruciforme. (Voir Figure 7)

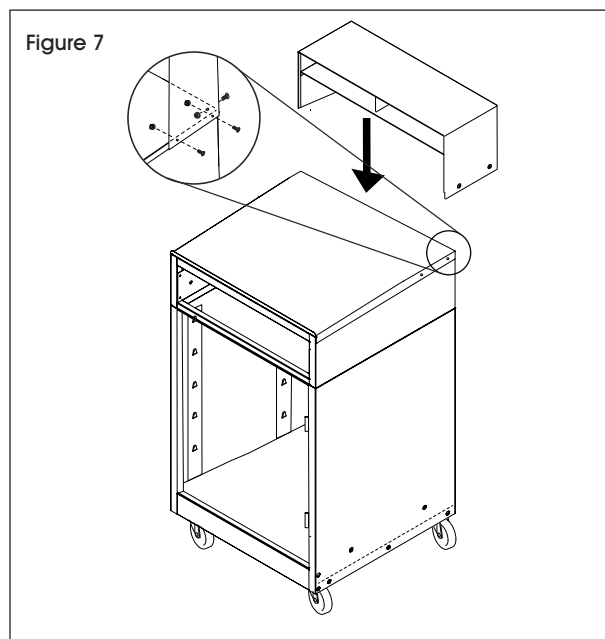

10. Placez la tablette centrale à la hauteur voulue sur les pinces de tablette situées à l'intérieur des panneaux arrière et latéraux. (Voir Figure 8)

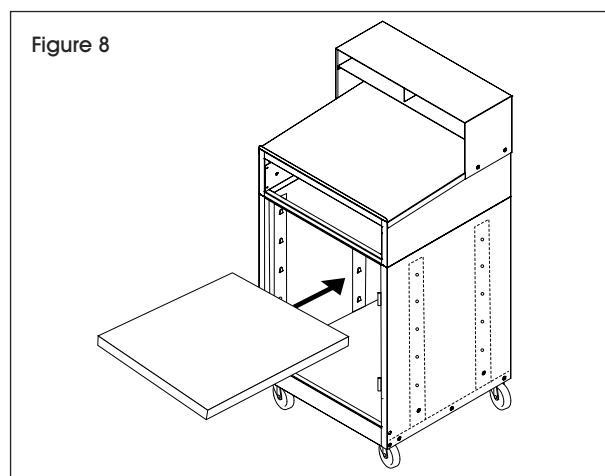

MONTAGE SUITE

11. Fixez la porte aux charnières à l'aide de quatre boulons cruciformes M5 x 8 et écrous hexagonaux en vous servant de la clé de 8 mm et du tournevis cruciforme. (Voir Figure 9)

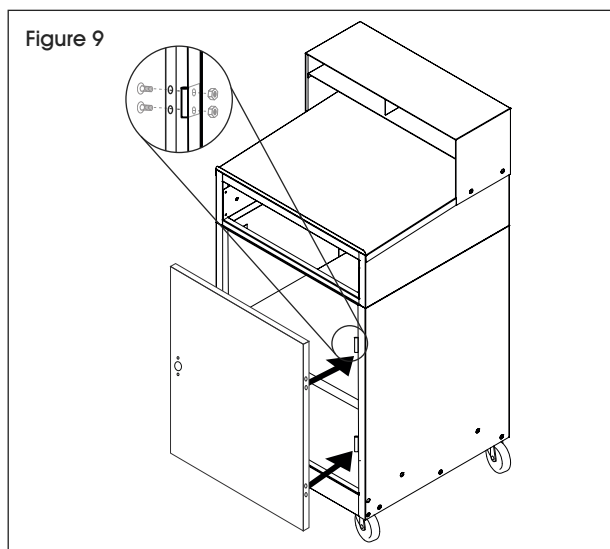

12. Insérez la poignée de porte dans la porte sans serrer et vissez deux boulons cruciformes à tête cylindrique bombée M5 x 5 dans la poignée à partir de l'intérieur de la porte. Ne serrez pas. (Voir Figure 10)

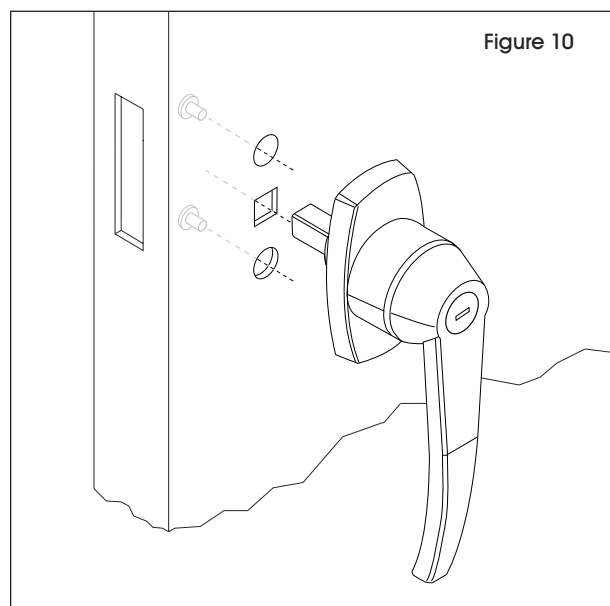

13. Sur le côté intérieur de la porte, placez la serrure à travers le filetage de la poignée de porte et le trou sur le côté de la porte. Fixez la poignée à l'aide des deux boulons cruciformes à tête cylindrique bombée M5 x 5 et du tournevis cruciforme. (Voir Figures 11 et 12)

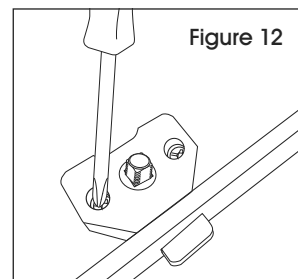
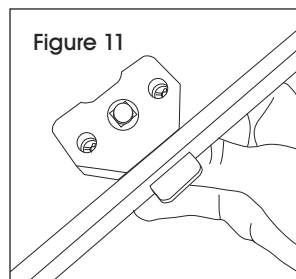

14. Fixez la serrure de porte en plaçant la rondelle de blocage et le grand écrou hexagonal sur le filetage de la poignée de porte et serrez à l'aide d'une clé de 17 mm. (Voir Figure 13)

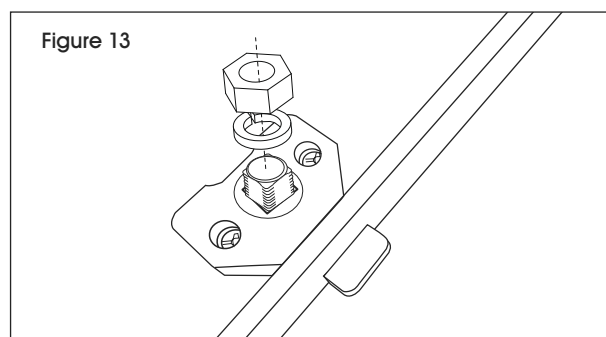

15. Insérez le tiroir. (Voir Figure 14)

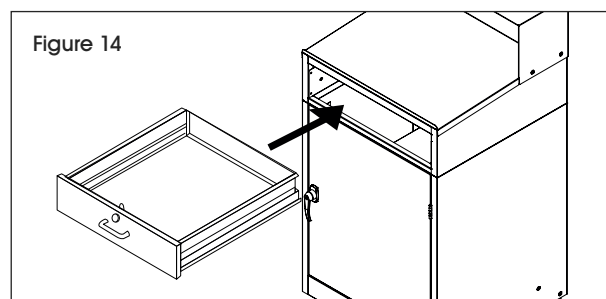

ULINE

1-800-295-5510
uline.ca