

ULINE

DOWNTOWN COLLECTION

1-800-295-5510
uline.com

Para Español, vea páginas 9-16.
Pour le français, consulter les pages 17-24.

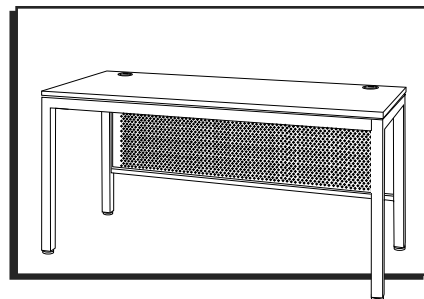

TOOLS NEEDED

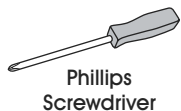

Two Person Assembly
Recommended

DESK AND TABLE ASSEMBLY PARTS LIST



M6 x 12 mm Bolt x 16

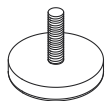

Adjustable Glide x 4

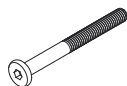

M6 x 65 mm Bolt x 10
(8 for H-8948 and H-8999)



Black Grommet x 2



Silver Grommet x 2



M6 x 12 mm
Modesty Panel Bolt x 4



Adhesive Cover x 4

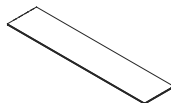

Acrylic Panel x 1
(optional)

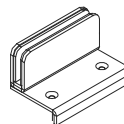

Bracket with Holder x 2
(optional)



M6 x 15 mm
Privacy Panel Bolt x 4
(optional)

DESK AND TABLE ASSEMBLY



- For Privacy Workstation assembly, refer to instructions included with Panels.
- For Reception Desk assembly, refer to instructions included with Reception Desk Shell.



NOTE: Assemble unit on a smooth, non-marring surface to prevent scratching. Check that you have all parts listed.

1. Slide support frame over leg connector and attach using four M6 x 12 mm bolts. Repeat for remaining three leg connectors. (See Figure 1)

Figure 1

Follow hole patterns
on frame as shown.

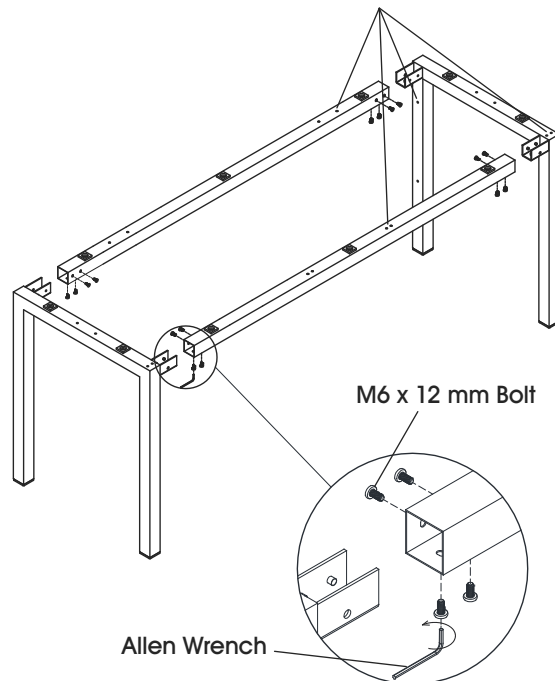

DESK AND TABLE ASSEMBLY CONTINUED

2. Insert adjustable glide into foot of each leg.
(See Figure 2)

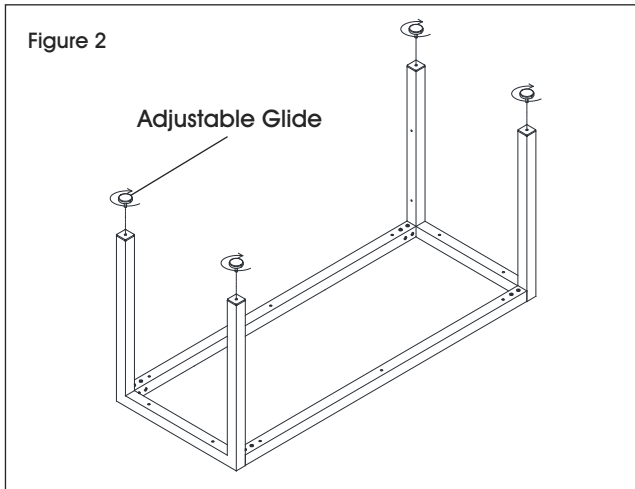

- For Desk and Table assembly, proceed to Step 3.
- For L-Desk and L-Desk Workstation assembly, proceed to Step 1 on page 4.
- For Back-to-Back Workstation assembly, proceed to Step 1 on page 6.

3. (Optional) If privacy panel was purchased, align bracket with holes on top of support frame and attach using two M6 x 15 mm bolts. Repeat for remaining holes on same side of support frame. Insert acrylic panel into brackets with holder. (See Figure 3)

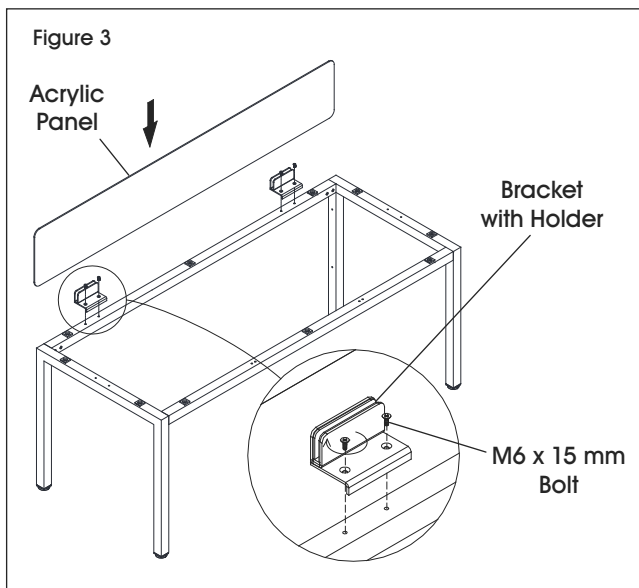

NOTE: If privacy panel is attached, keep frame upright for Steps 4-5. (Optional privacy panel is not shown.)

4. Place top on ground with underside facing up and flip over assembled frame. Align holes on top with holes on frame and attach using 10 M6 x 65 mm bolts. (See Figure 4)



NOTE: For H-8948 and H-8999, attach top and frame using eight M6 x 65 mm bolts.

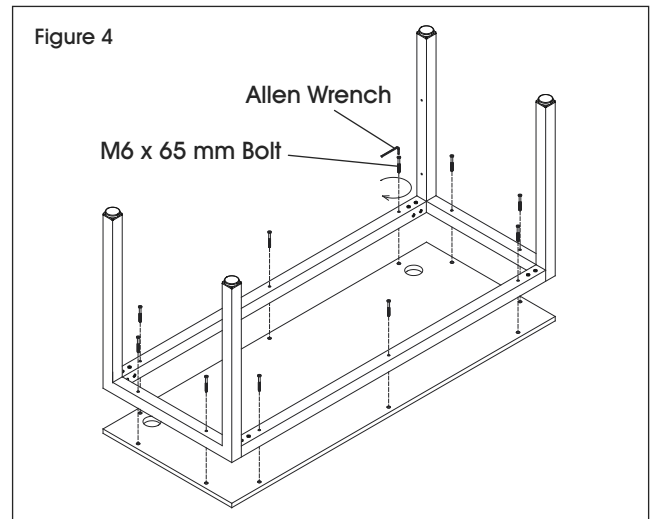

5. If assembling a desk, align holes on modesty panel with holes on legs and attach using four M6 x 12 mm bolts. (See Figure 5) If assembling a table, apply adhesive covers to holes on legs. (See Figure 6)



NOTE: Ensure desktop is attached before attaching modesty panel.

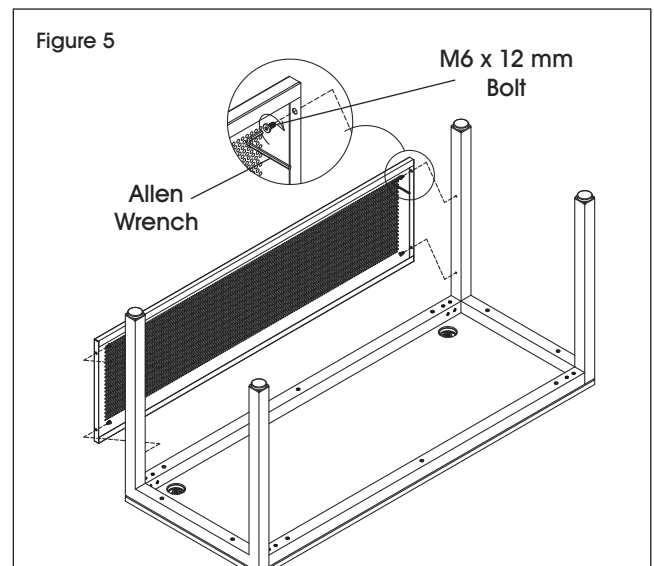

DESK AND TABLE ASSEMBLY CONTINUED

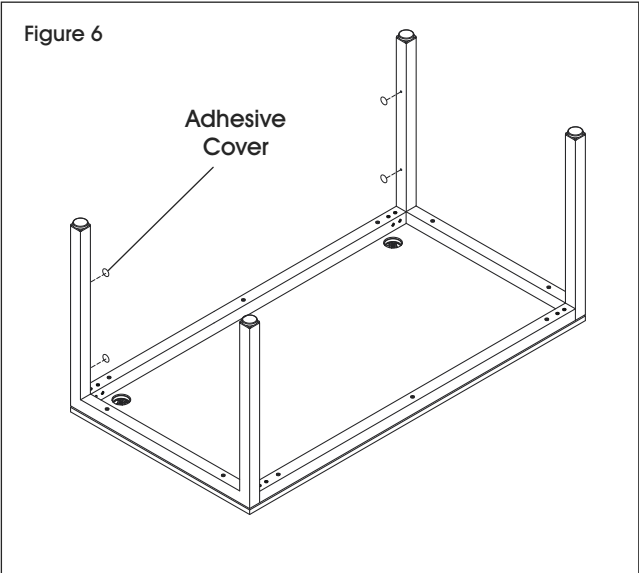

6. Desk/table is now fully assembled. Using two people, carefully flip the assembled desk/table onto the feet. Insert black or silver grommets depending on preference.

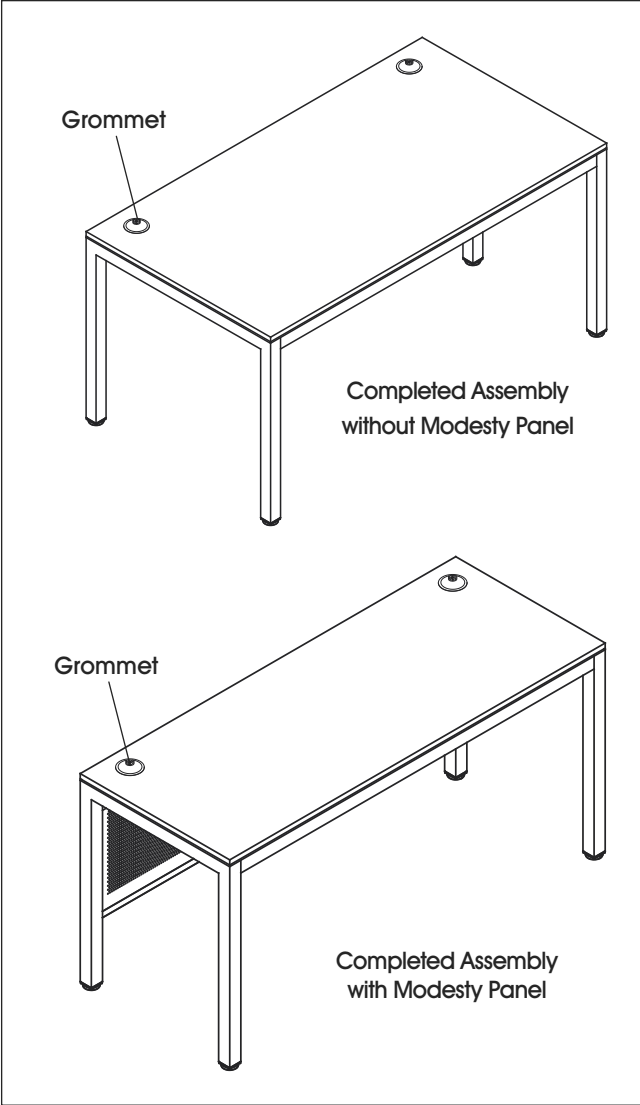

L-DESK RETURN ASSEMBLY PARTS LIST



M6 x 12 mm Bolt x 8

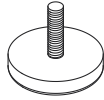

Adjustable Glide x 2

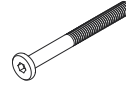

M6 x 65 mm Bolt x 6

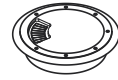

Black Grommet x 1

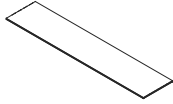

Acrylic Panel x 1
(optional)

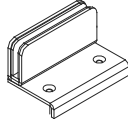

Bracket with Holder x 2
(optional)



M6 x 15 mm Bolt x 4
(optional – 4 for H-8220
or H-8221)



Silver Grommet x 1

L-DESK RETURN ASSEMBLY

- Slide support frame over leg connector and attach using four M6 x 12 mm bolts. Repeat for second leg connector. (See Figure 7)

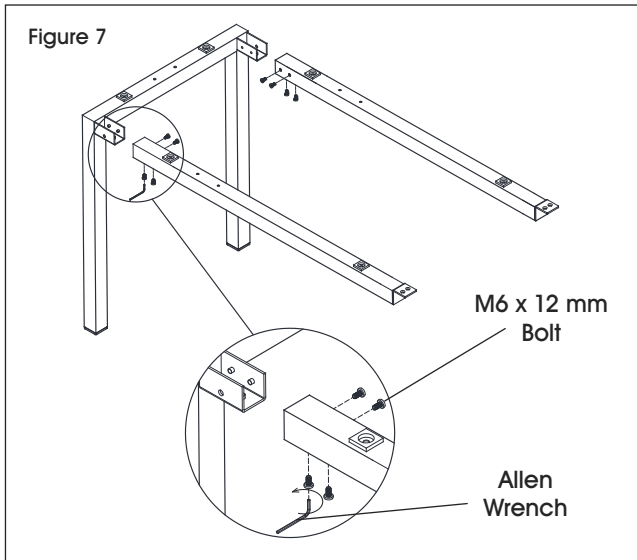

- Insert adjustable glide into foot of each leg. (See Figure 8)

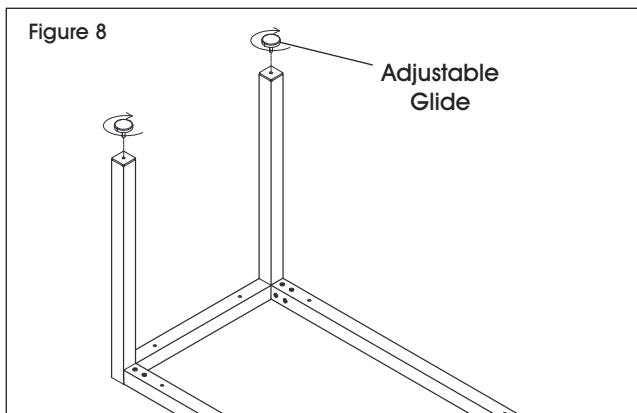

- Align holes of assembled L-Desk return over holes on desk frame and attach using two M6 x 15 mm bolts. Repeat for second set of holes. (See Figure 9)



NOTE: Diagram shows right-hand L-Desk configuration. For left-hand L-Desk configuration, attach return frame to opposite side.

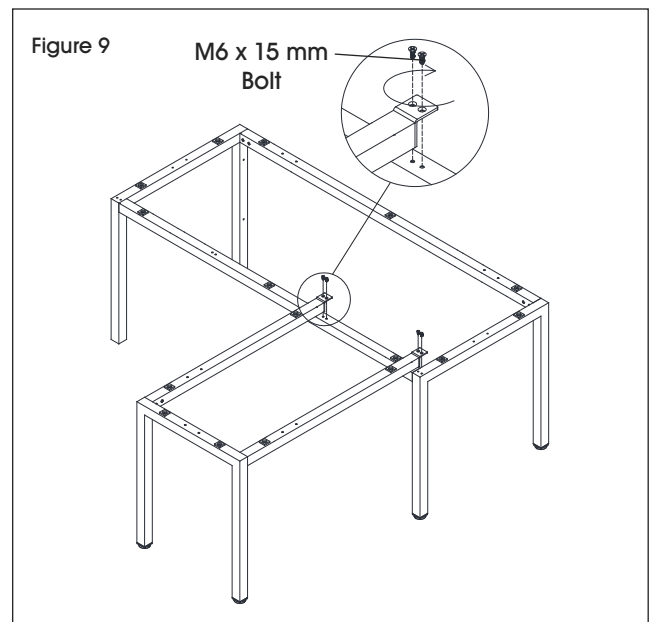

For L-Desk assembly, proceed to Step 4.

For L-Desk Workstation assembly, proceed to Step 1 on page 7.

L-DESK RETURN ASSEMBLY CONTINUED

4. (Optional) If privacy panels were purchased, align bracket with holes on top of support frame and attach using two M6 x 15 mm bolts. Repeat for opposite side of support frame. Insert acrylic frame into brackets with holder. (See Figure 10)

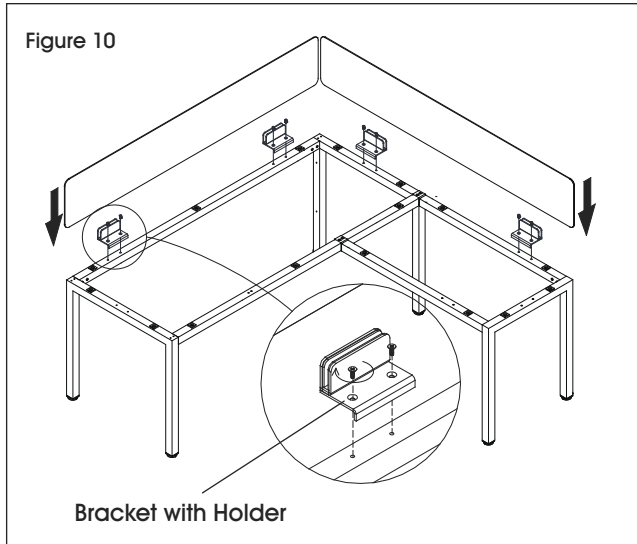

5. Place tops over frame. Align holes on tops with holes on frame and attach using 16 M6 x 65 mm bolts. (See Figure 11)

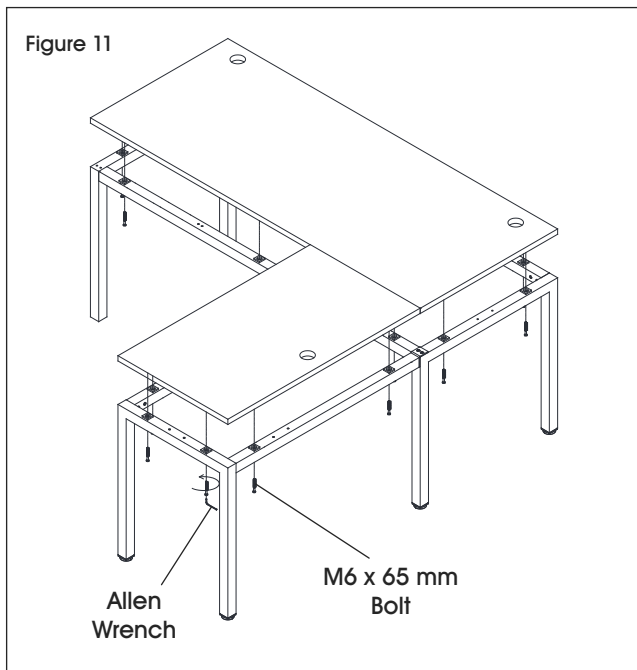

6. Align holes on modesty panel with holes on legs and attach using four M6 x 15 mm bolts. (See Figure 12)

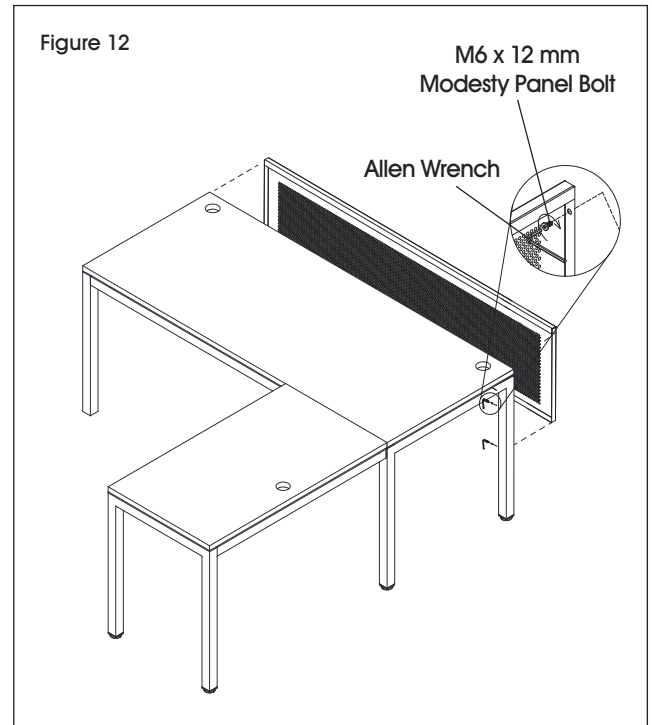

7. L-Desk is now fully assembled. Insert black or silver grommets depending on preference.

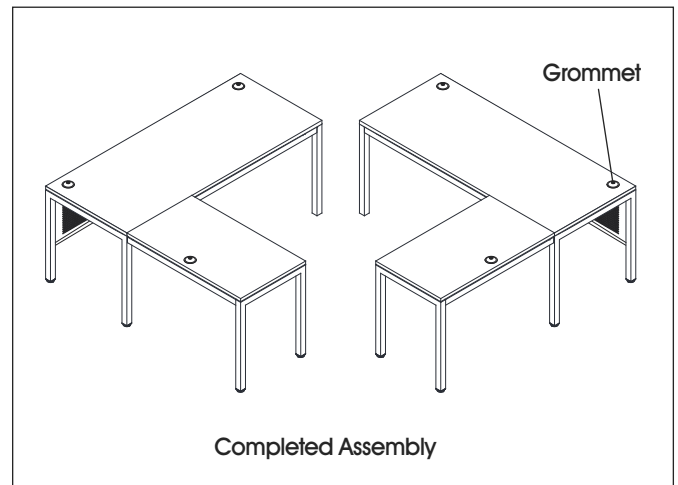

BACK-TO-BACK WORKSTATION PARTS LIST

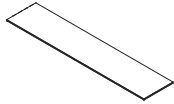

Acrylic Panel x 1

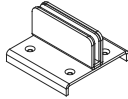

Dual Bracket with Holder x 2

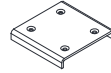

Dual Bracket x 2



M6 x 15 mm Bolt x 16

BACK-TO-BACK WORKSTATION ASSEMBLY

1. Place desk frames together. Align dual bracket with holder with holes on top of support frames and attach using four M6 x 15 mm bolts. Repeat for remaining dual brackets with holder. Insert acrylic panel into dual brackets with holder. Align dual bracket with holes on top of leg frames and attach using four M6 x 15 mm bolts. Repeat for remaining dual brackets. (See Figure 13)

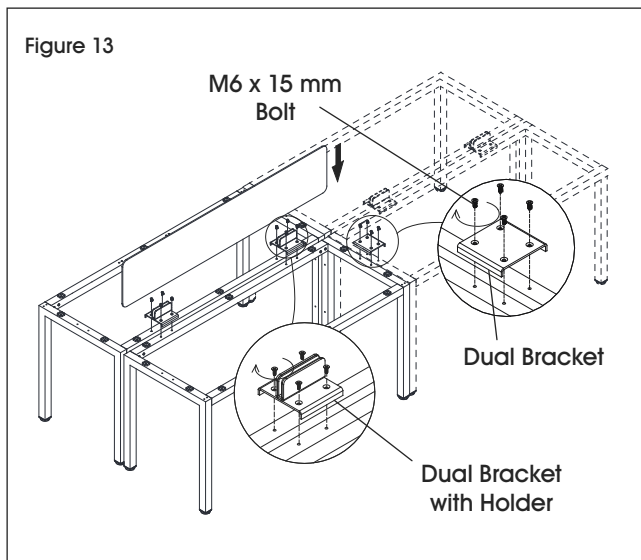

-  **NOTE:** Additional Back-to-Back sets can be added to create longer configurations. To extend workstation, attach dual brackets to end of desks and connect additional sets during this step.

2. Place tops over frames. Align holes on tops with holes on frames and attach using M6 x 65 mm bolts. (See Figure 14)

-  **NOTE:** Parts from page 1 will be used during this step.

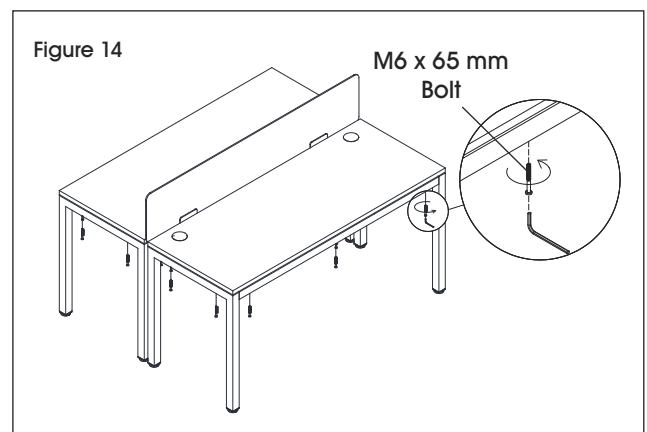

3. Align holes on modesty panel with holes on legs and attach using four M6 x 15 mm bolts. Insert black or silver grommets based on preference. (See Figure 15)

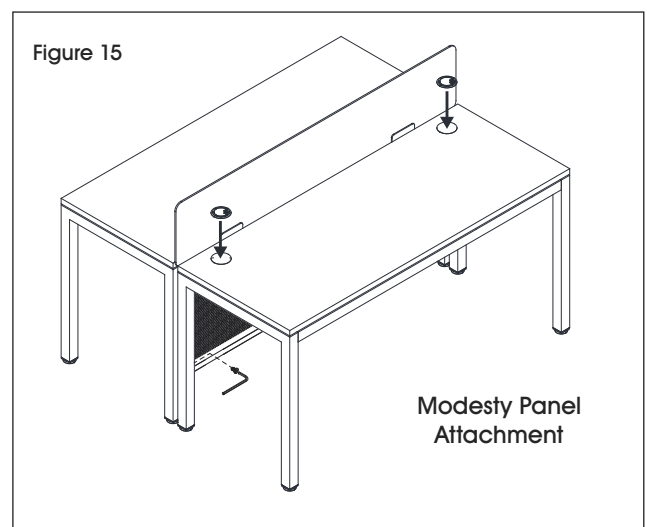

BACK-TO-BACK WORKSTATION ASSEMBLY CONTINUED

4. Workstation is now fully assembled.

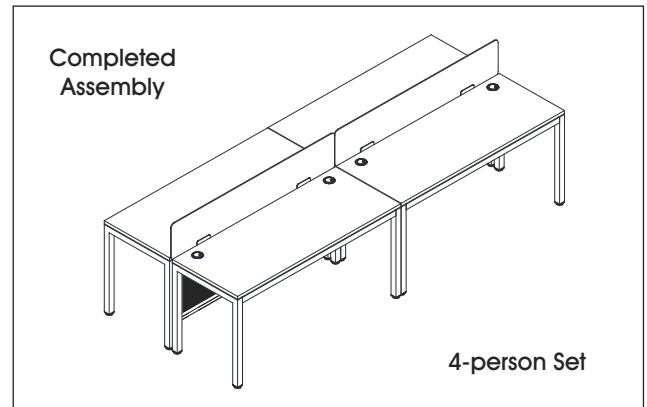
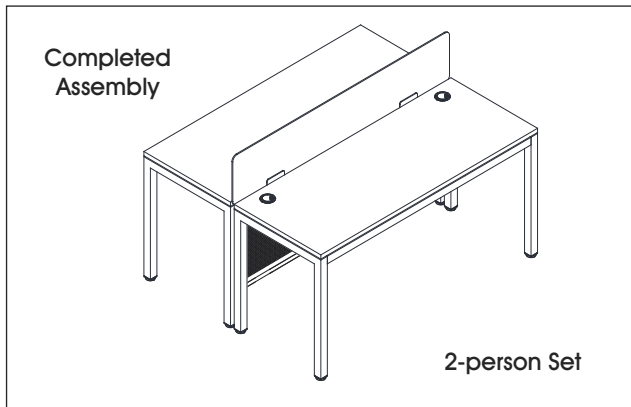

L-DESK WORKSTATION PARTS LIST

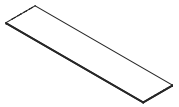

Acrylic Panel x 1

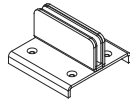

Dual Bracket with Holder x 2

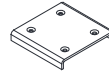

Dual Bracket x 2



M6 x 15 mm Bolt x 16

L-DESK WORKSTATION ASSEMBLY

1. Place desk frames together. Align dual bracket with holder with holes on top of support frame and attach using four M6 x 15 mm bolts. Repeat for remaining dual brackets with holder. Insert acrylic panel into dual brackets with holder. Align dual bracket with holes on top of leg frames and attach using four M6 x 15 mm bolts. Repeat for remaining dual brackets. (See Figure 16)



NOTE: Additional L-Desk sets can be added to create longer configurations. To extend workstation, attach dual brackets to end of desks and connect additional sets during this step.

2. Place tops over frames. Align holes on tops with holes on frames and attach using M6 x 65 mm bolts. (See Figure 17)



NOTE: Parts from page 1 will be used during this step.

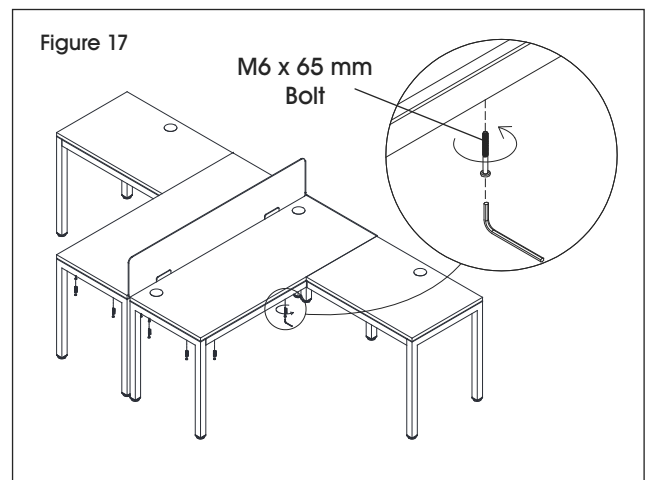
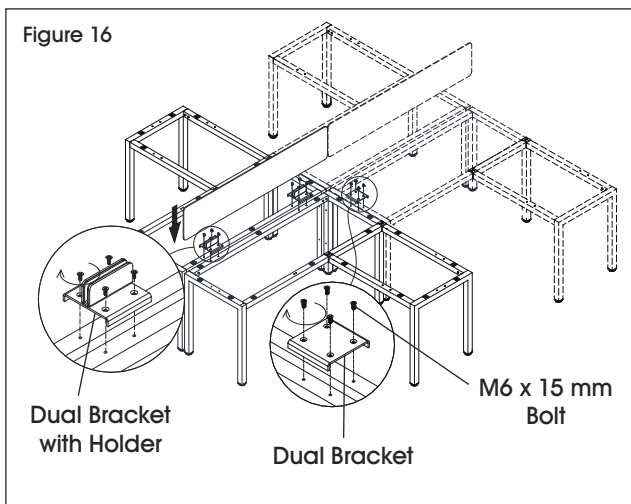

L-DESK WORKSTATION ASSEMBLY CONTINUED

3. Attach using four M6 x 15 mm bolts. Insert black or silver grommets depending on preference. (See Figures 18-19)

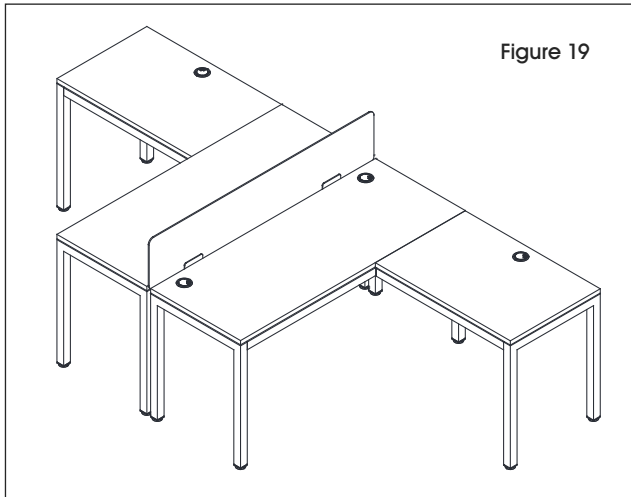
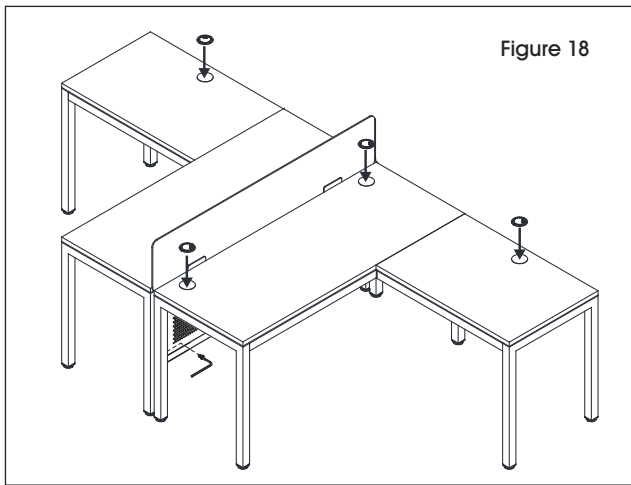

4. Workstation is now fully assembled.

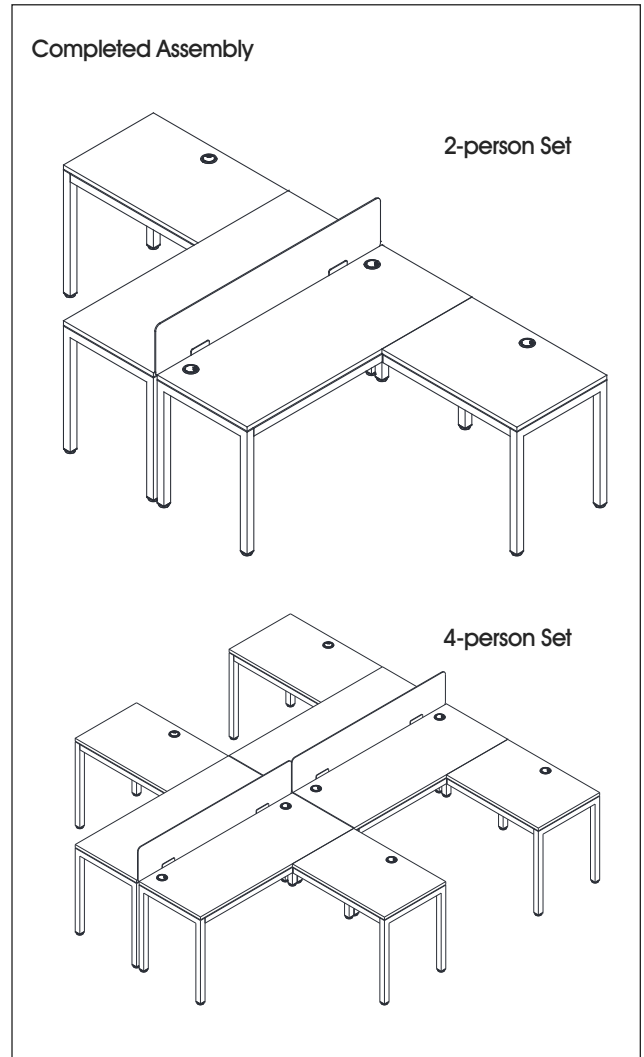

ULINE

1-800-295-5510
uline.com

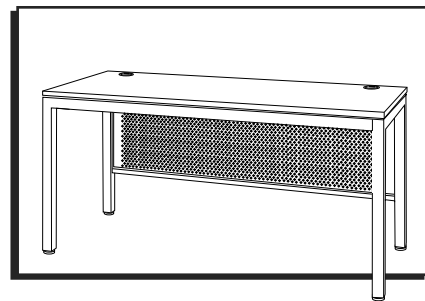
**HERRAMIENTAS NECESARIAS**

Se recomienda Armar Entre Dos Personas

LISTA DE PARTES PARA ENSAMBLE DEL ESCRITORIO Y MESA

16 Pernos M6 x 12 mm

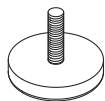

4 Tapas Niveladoras

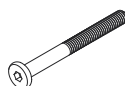

10 Pernos M6 x 65 mm (8 para H-8948 y H-8999)



2 Ojales Negros



2 Ojales Plateados



4 Pernos del Recato M6 x 12 mm



4 Cubiertas Adhesivas

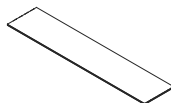

1 Panel de Acrílico (opcional)

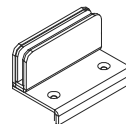

2 Soportes con Asa (opcionales)



4 Pernos del Panel de Privacidad M6 x 15 mm (opcionales)

ENSAMBLE DEL ESCRITORIO Y LA MESA

• Para el ensamble de la Estación de Trabajo de Privacidad, vea las instrucciones incluidas con los Paneles.

• Para el ensamble del Escritorio de Recepción, vea las instrucciones incluidas con el Armazón del Escritorio.



NOTA: Ensamble la unidad sobre una superficie lisa que no deje marcas, para evitar rayones. Verifique que cuente con todas las partes listadas.

1. Deslice el armazón de soporte sobre el conector de la pata y fíjelo utilizando cuatro pernos M6 x 12 mm. Repita la operación con los tres conectores para patas restantes. (Vea Diagrama 1)

Diagrama 1

Siga el patrón de orificios en el armazón como se muestra.

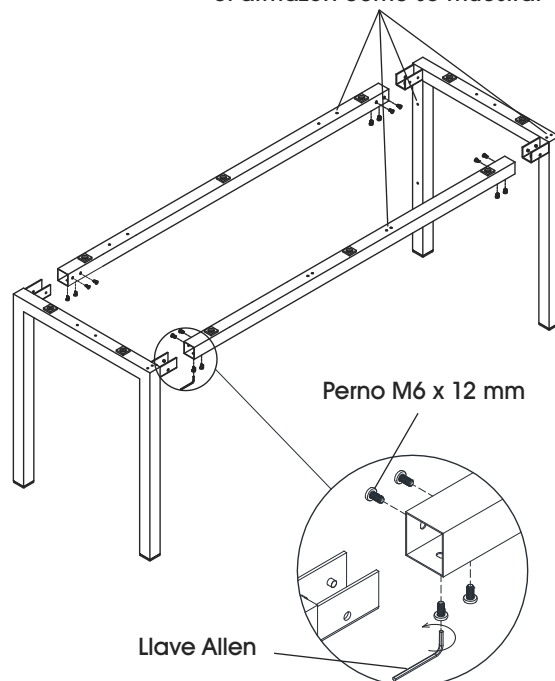

CONTINUACIÓN DEL ENSAMBLE DEL ESCRITORIO Y LA MESA

2. Inserte la tapa niveladora en cada pata.
(Vea Diagrama 2)

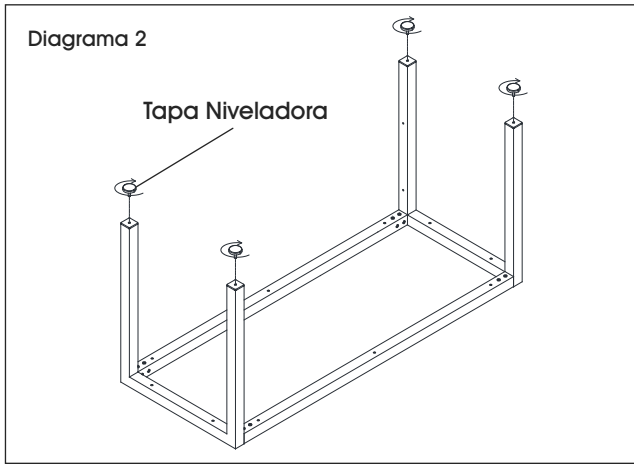

- Para el ensamble del Escritorio y Mesa, proceda al Paso 3.
- Para el ensamble del Escritorio en L y la Estación de Trabajo con Escritorio en L, proceda al Paso 1 en la página 12.
- Para el ensamble de la Estación de Trabajo Tipo Bancada, proceda al Paso 1 en la página 14.

3. (Opcional) Si ya adquirió el panel de privacidad, alinee el soporte con los orificios en la parte superior del armazón de soporte y fije utilizando pernos M6 x 15 mm. Repita la operación con los orificios restantes en el mismo lado del armazón de soporte. Inserte el panel de acrílico en los soportes con asa. (Vea Diagrama 3)

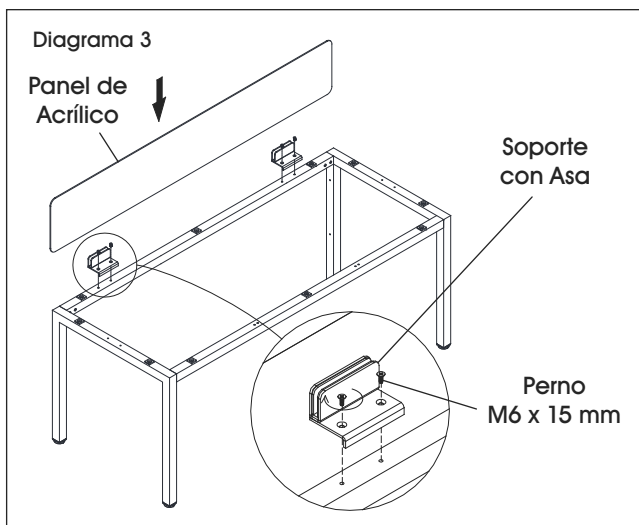

NOTA: Si coloca el panel de privacidad, mantenga vertical el armazón para los Pasos 4-5. (El panel de privacidad opcional no se muestra).

4. Coloque la cubierta en el piso con la parte inferior hacia arriba y voltee el armazón ensamblado. Alinee los orificios de la cubierta con los orificios del armazón y fíjelos utilizando 10 pernos M6 x 65 mm. (Vea Diagrama 4)



NOTA: Para H-8948 y H-8999, una la cubierta y el armazón utilizando ocho pernos M6 x 65 mm.

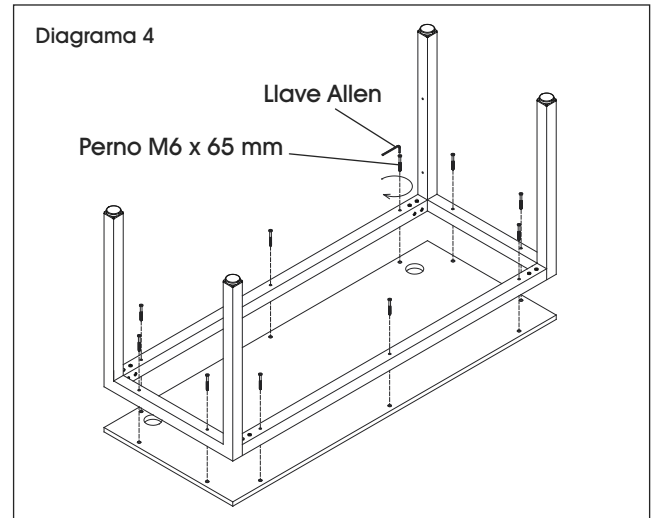

5. Si ensambla un escritorio, alinee los orificios del recato con los orificios de las patas y fíjelos utilizando cuatro pernos M6 x 12 mm. (Vea Diagrama 5) Si ensambla una mesa, coloque las cubiertas adhesivas a los orificios en las patas. (Vea Diagrama 6)



NOTA: Asegúrese de fijar la cubierta antes de colocar el recato.

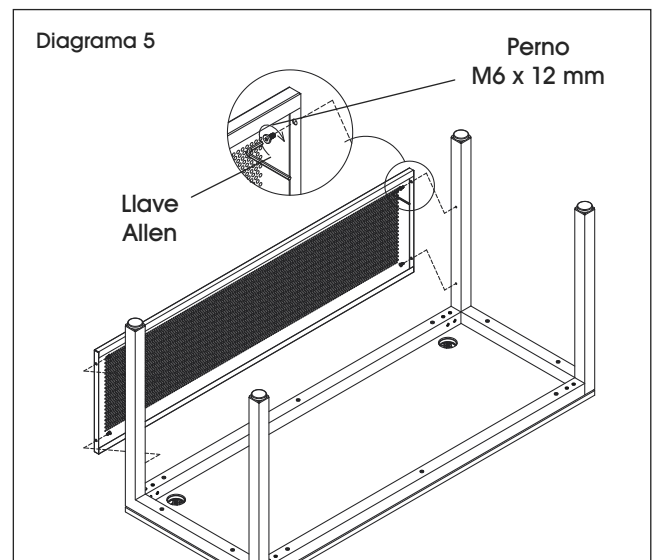

CONTINUACIÓN DEL ENSAMBLE DEL ESCRITORIO Y LA MESA

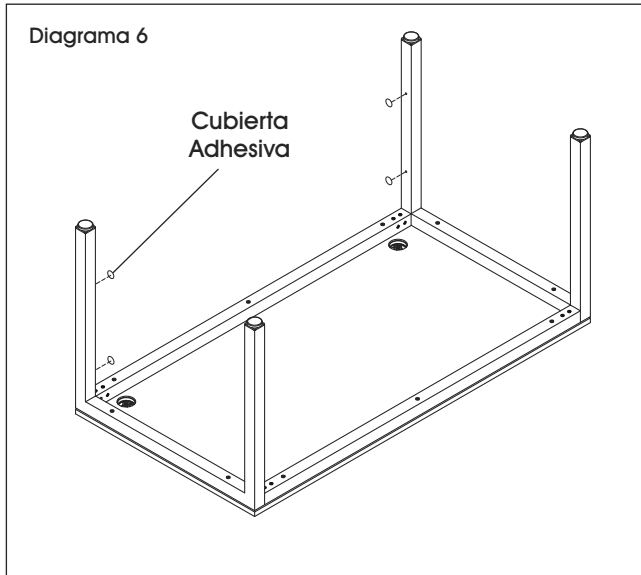

6. El escritorio o mesa quedaron ensamblados por completo. Entre dos personas, volteen con cuidado el ensamble del escritorio o mesa sobre las patas. Inserte los ojales negros o plateados según prefiera.

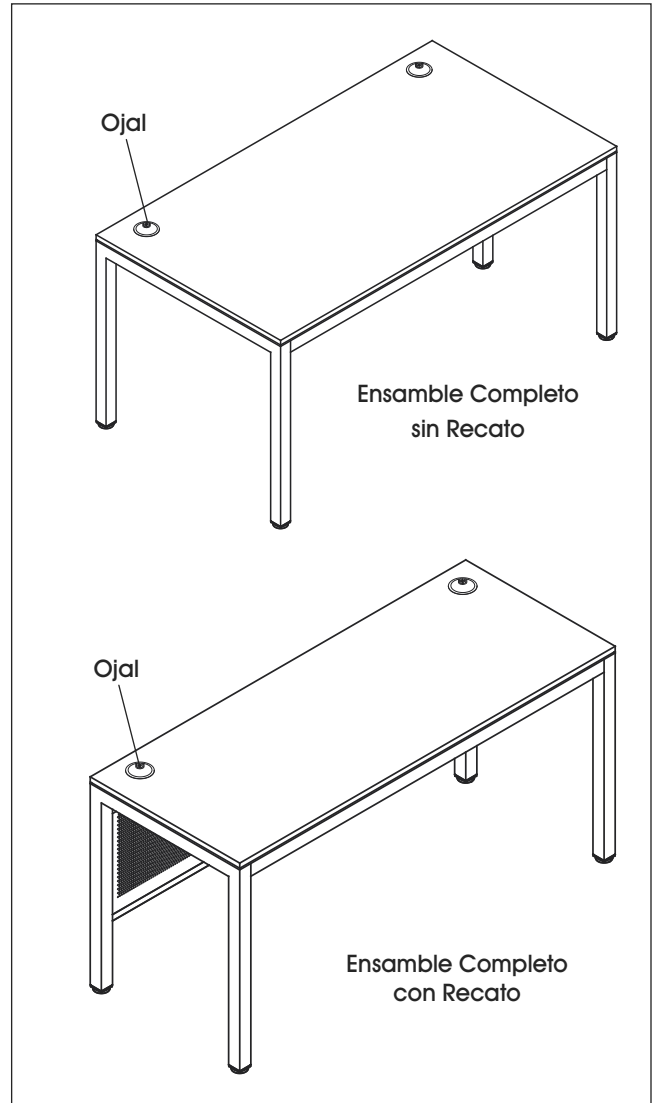

LISTA DE PARTES PARA ENSAMBLE DEL ESCRITORIO EN L



8 Pernos M6 x 12 mm

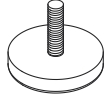

2 Tapas Niveladoras

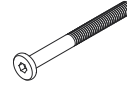

6 Pernos M6 x 65 mm

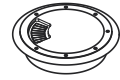

1 Ojal Negro



1 Panel de Acrílico
(opcional)

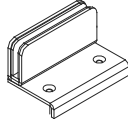

2 Soportes con Asa
(opcionales)



4 Pernos M6 x 15 mm
(opcionales – 4 para
H-8220 o H-8221)



1 Ojal Plateado

ENSAMBLE DEL RETORNO PARA ESCRITORIO EN L

1. Deslice el armazón de soporte sobre el conector de la pata y fíjelo utilizando cuatro pernos M6 x 12 mm. Repita la operación con la segunda pata. (Vea Diagrama 7)

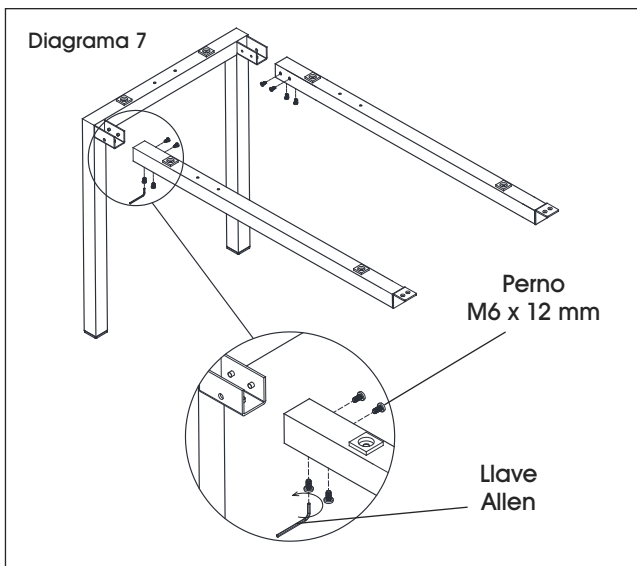

2. Inserte una tapa niveladora en cada pata. (Vea Diagrama 8)

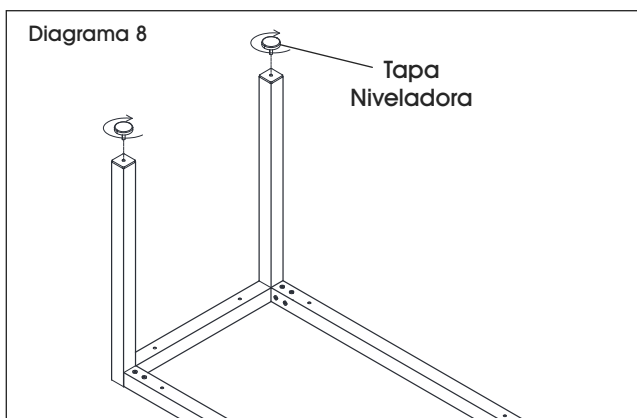

3. Alinee los orificios del ensamblaje del retorno para Escritorio en L sobre los orificios del armazón del escritorio y fíje utilizando dos pernos M6 x 15 mm. Repita con el segundo set de orificios. (Vea Diagrama 9)



NOTA: El diagrama muestra la configuración del lado derecho del Escritorio en L. Para la configuración del lado izquierdo del Escritorio en L, fije el armazón del retorno al lado opuesto.

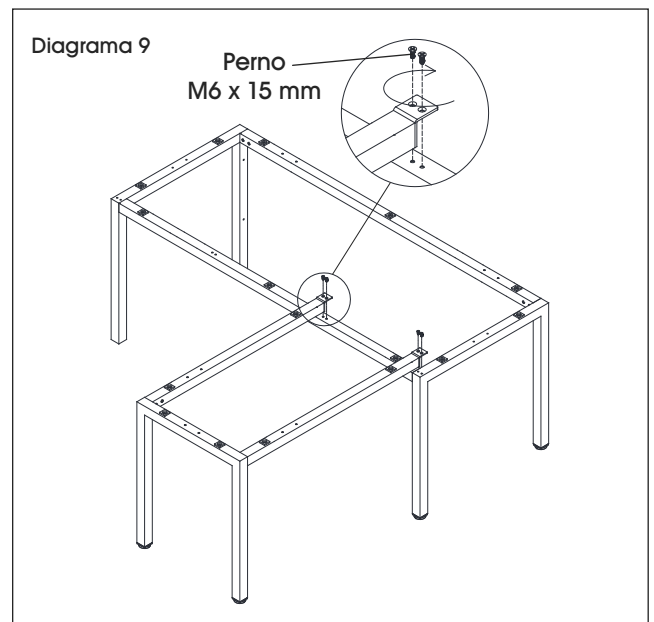

Para el ensamblaje del Escritorio en L proceda al Paso 4.

Para el ensamblaje de la Estación de Trabajo en L, proceda al Paso 1 en la página 15.

CONTINUACIÓN DEL ENSAMBLE DEL RETORNO PARA ESCRITORIO EN L

4. (Opcional) Si ya adquirió los paneles de privacidad, alinee el soporte con los orificios en la parte superior del armazón de soporte y fíjelo utilizando dos pernos M6 x 15 mm. Repita la operación con el lado opuesto del armazón de soporte. Inserte el armazón de acrílico en los soporte con asa. (Vea Diagrama 10)

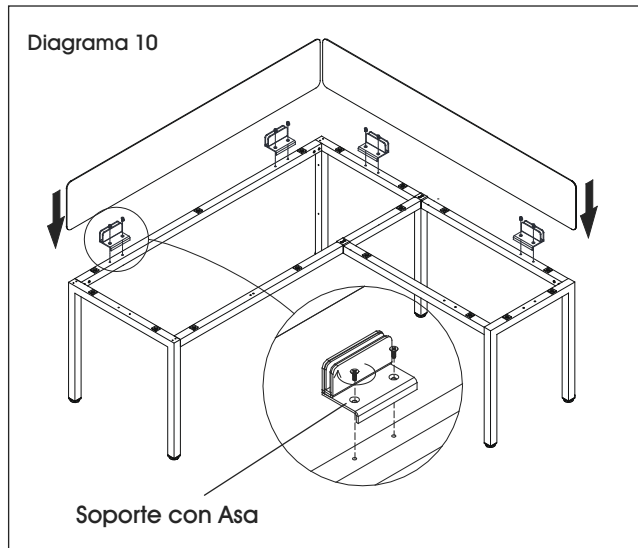

5. Coloque las cubiertas sobre el armazón. Alinee los orificios de las cubiertas con los orificios del armazón y fije utilizando 16 pernos M6 x 65 mm. (Vea Diagrama 11)

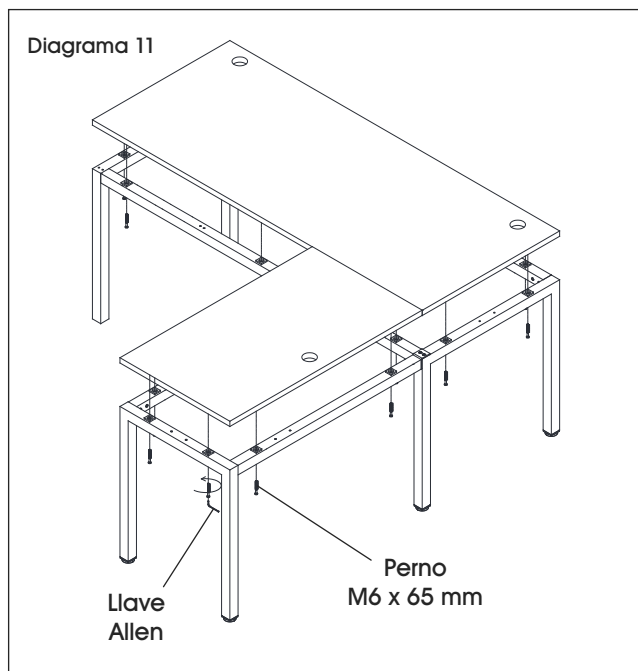

6. Alinee los orificios del recato con los orificios de las patas y fije utilizando cuatro pernos M6 x 15 mm. (Vea Diagrama 12)

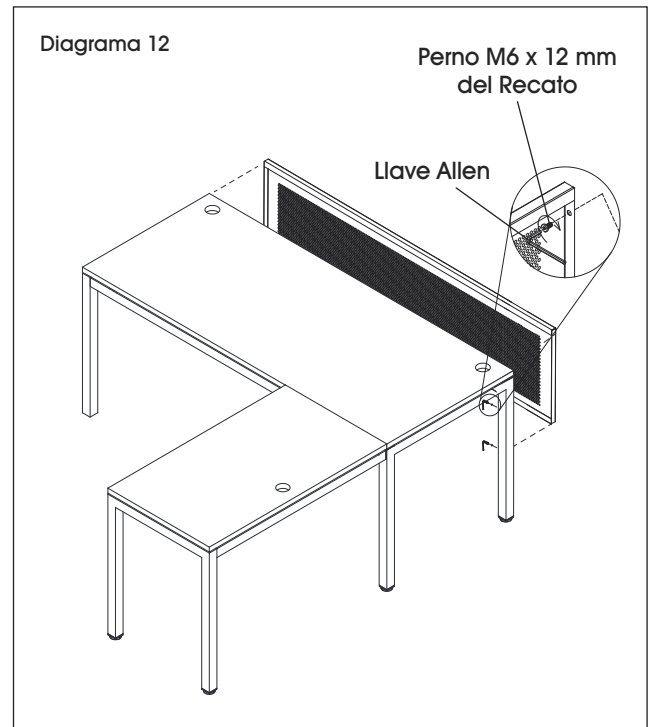

7. El Escritorio en L quedó ensamblado por completo. Inserte los ojales negros o plateados según prefiera.

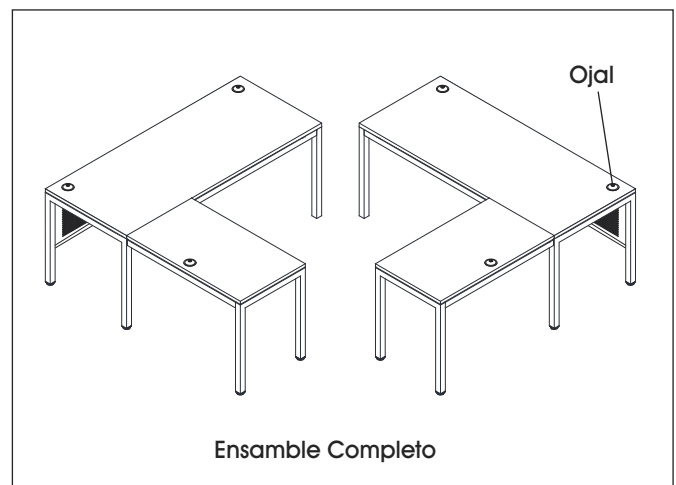

LISTA DE PARTES PARA ESTACIÓN DE TRABAJO TIPO BANCADA



1 Panel de Acrílico

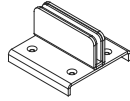

2 Soportes Duales con Asa

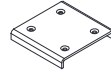

2 Soportes Duales



16 Pernos M6 x 15 mm

ENSAMBLE DE LA ESTACIÓN DE TRABAJO TIPO BANCADA

1. Junte los armazones del escritorio. Alinee el soporte dual con asa con los orificios de la parte superior de los armazones y fíjelos utilizando cuatro pernos M6 x 15 mm. Repita la operación con los soportes duales con asa restantes. Inserte el panel de acrílico en los soportes duales con asa. Alinee el soporte dual con los orificios de la parte superior de los armazones de las patas y fíjelos utilizando cuatro pernos M6 x 15 mm. Repita la operación con los soportes duales restantes. (Vea Diagrama 13)

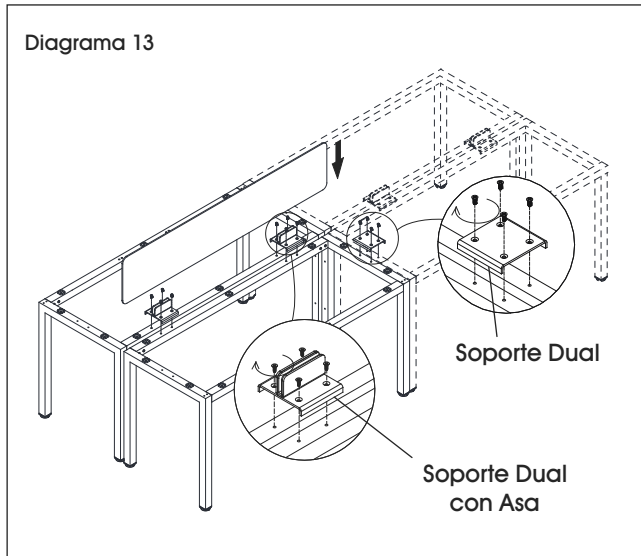

- NOTA:** Puede agregar sets Tipo Bancada adicionales para diseñar configuraciones alargadas. Para extender la estación de trabajo, fije los soportes duales en el extremo de los escritorios y conecte los sets adicionales durante este paso.

2. Coloque las cubiertas sobre los armazones. Alinee los orificios de las cubiertas con los orificios de los armazones y fíjelos utilizando pernos M6 x 65 mm. (Vea Diagrama 14)

NOTA: En este paso se utilizarán las partes de la página 9.

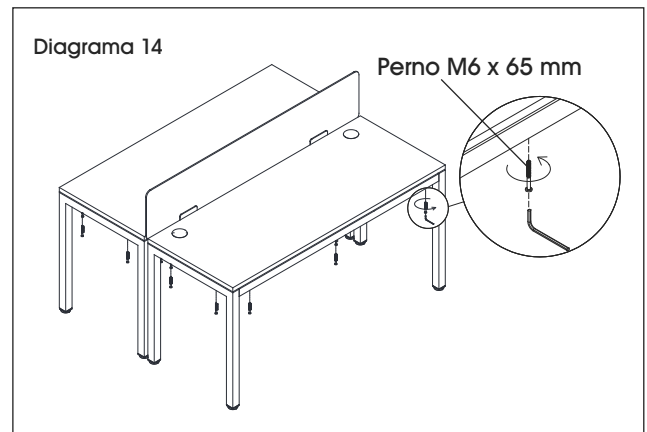

3. Alinee los orificios del recato con los orificios de las patas y fíjelos utilizando cuatro pernos M6 x 15 mm. Inserte los ojales negros o plateados según prefiera. (Vea Diagrama 15)

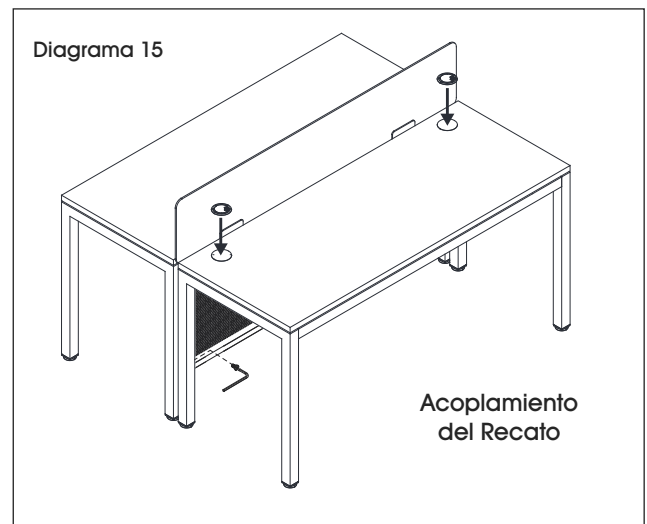

CONTINUACIÓN DEL ENSAMBLE DE LA ESTACIÓN DE TRABAJO TIPO BANCADA

4. La Estación de Trabajo quedó ensamblada por completo.

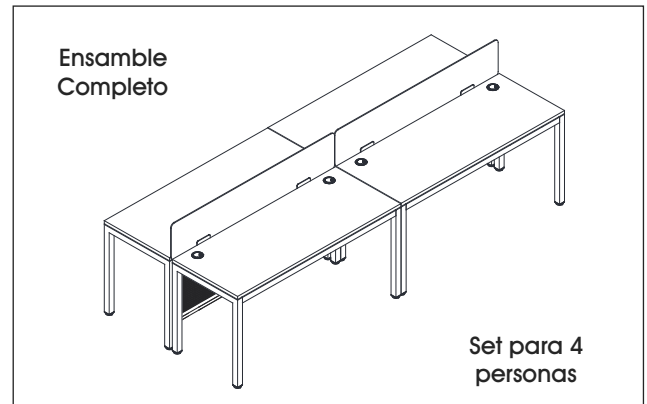
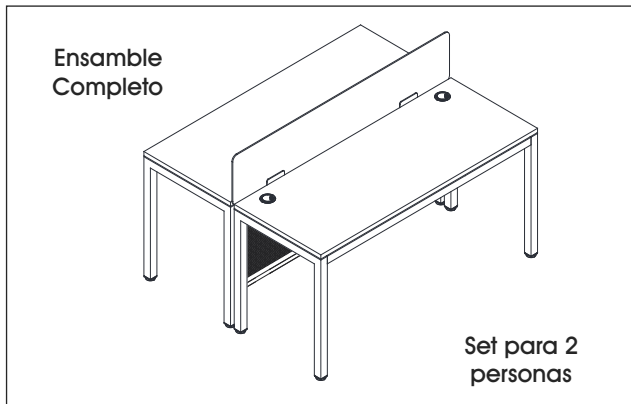

LISTA DE PARTES DE LA ESTACIÓN DE TRABAJO CON ESCRITORIO EN L

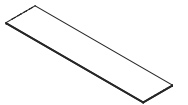

1 Panel de Acrílico

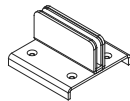

2 Soportes Duales con Asa

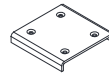

2 Soportes Duales



16 Pernos M6 x 15 mm

ENSAMBLE DE LA ESTACIÓN DE TRABAJO CON ESCRITORIO EN L

1. Junte los armazones del escritorio. Alinee los orificios del soporte dual con asa con los orificios de la parte superior del armazón y fije utilizando cuatro pernos M6 x 15 mm. Repita la operación con los soportes duales con asa restantes. Inserte el panel de acrílico en los soportes duales con asa. Alinee el soporte dual con los orificios de la parte superior de los armazones de las patas y fíjelos utilizando cuatro pernos M6 x 15 mm. Repita la operación con los soportes duales restantes. (Vea Diagrama 16)



NOTA: Puede agregar sets de Escritorios en L adicionales para diseñar configuraciones alargadas. Para extender la estación de trabajo, fije los soportes duales en el extremo de los escritorios y conecte los sets adicionales durante este paso.

2. Coloque las cubiertas sobre los armazones. Alinee los orificios de las cubiertas con los orificios de los armazones y fíjelos utilizando pernos M6 x 65 mm. (Vea Diagrama 17)



NOTA: En este paso se utilizarán las partes de la página 9.

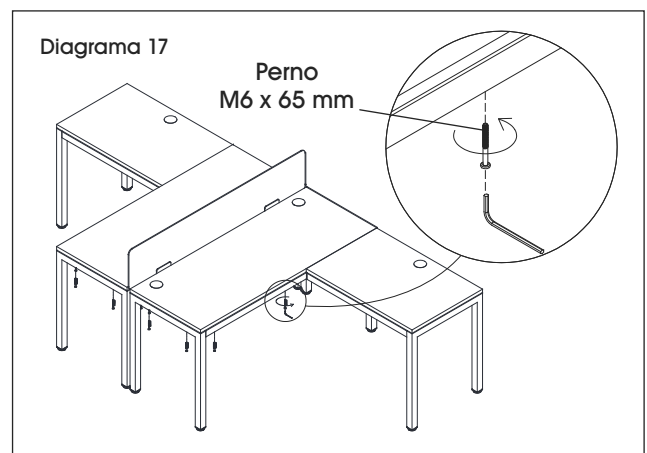
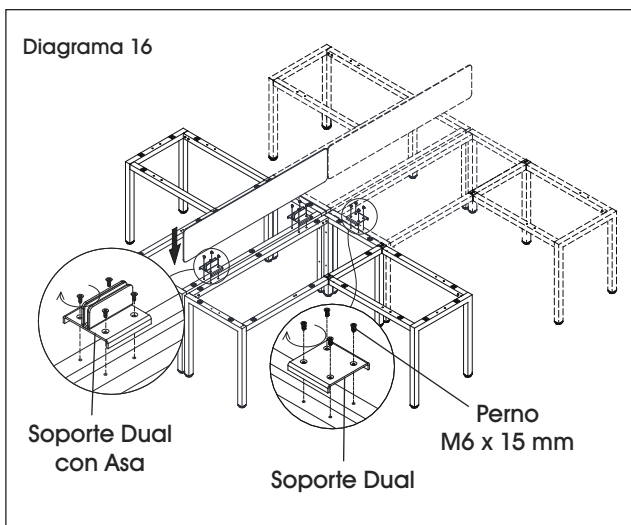

CONTINUACIÓN DEL ENSAMBLE DE LA ESTACIÓN DE TRABAJO CON ESCRITORIO EN L

3. Fije utilizando cuatro pernos M6 x 15 mm. Inserte los ojales negros o plateados según prefiera. (Vea Diagramas 18-19)

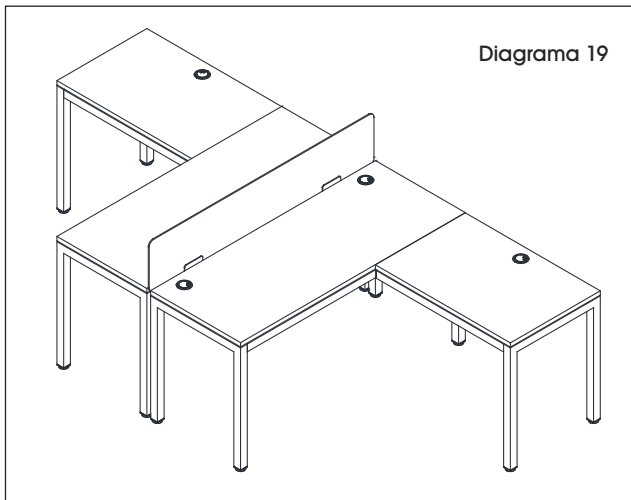
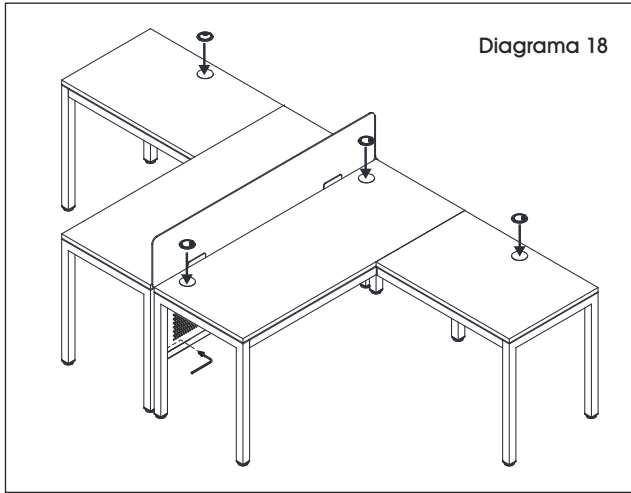

4. La Estación de Trabajo quedó ensamblada por completo.

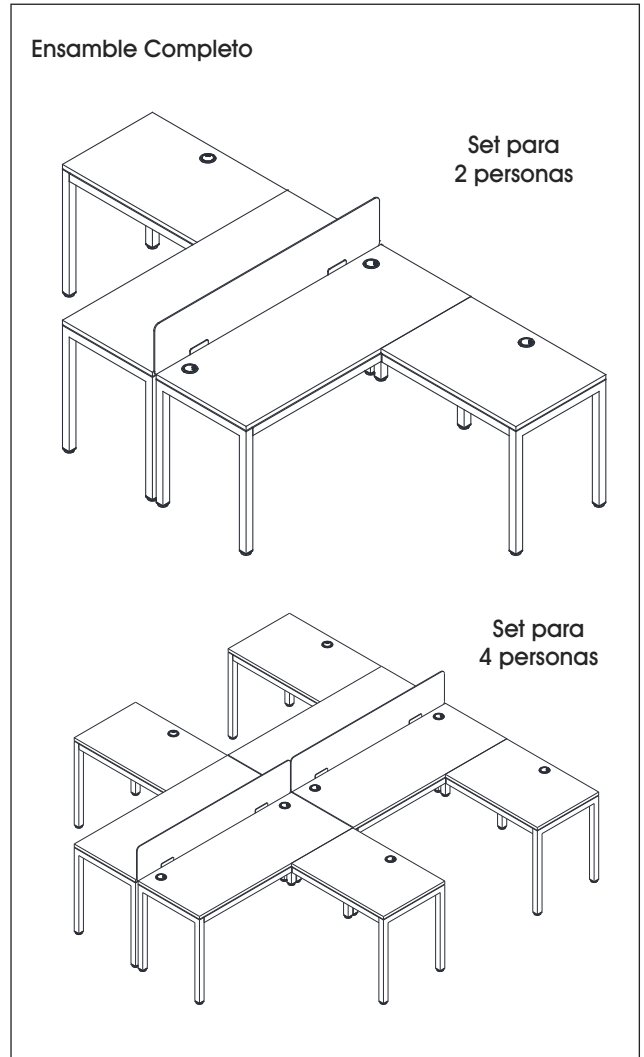

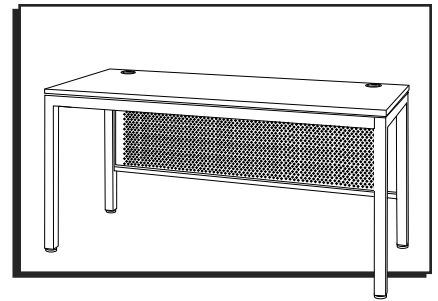
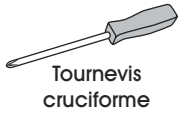
**OUTILS REQUIS**

Montage à deux personnes
recommandé

Liste des pièces pour le montage de la table et du bureau

Boulon M6 x 12 mm x 16

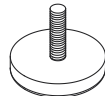

Patin ajustable x 4

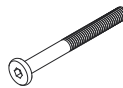

Boulon M6 x 65 mm x 10
(8 pour H-8948 et H-8999)

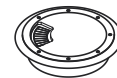

Passe-fil noir x 2



Passe-fil argenté x 2



Boulon pour panneau
cache-jambes
M6 x 12 mm x 4



Protection adhésive x 4

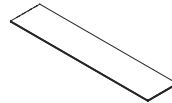

Panneau en acrylique x 1
(optionnel)

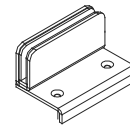

Support avec point
d'appui x 2
(optionnel)



Boulon M6 x 15 mm x 4
pour panneau
de séparation
(optionnel)

MONTAGE DE LA TABLE ET DU BUREAU

• Pour le montage du poste de travail avec panneau de séparation, reportez-vous aux instructions qui sont incluses avec les panneaux.

• Pour le montage du bureau de réception, reportez-vous aux instructions fournies avec la structure du meuble.



REMARQUE : Montez l'unité sur une surface lisse et non marquante afin de prévenir les égratignures. Vérifiez que toutes les pièces énumérées sont présentes.

1. Faites glisser le cadre de support par-dessus la ferrure de pied et fixez-le avec quatre boulons M6 x 12 mm. Répétez l'opération pour les trois autres ferrures de pied. (Voir Figure 1)

Figure 1

Suivez le schéma des trous sur le cadre comme illustré.

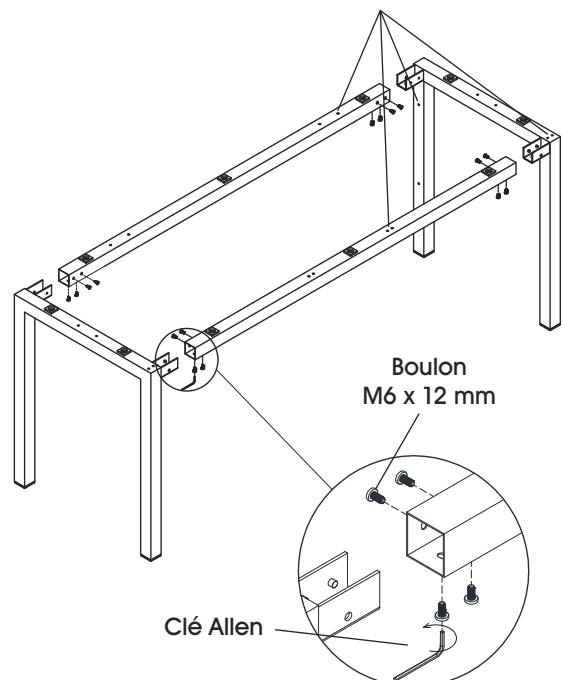

MONTAGE DE LA TABLE ET DU BUREAU SUITE

2. Insérez les patins ajustables dans l'extrémité des pieds. (Voir Figure 2)

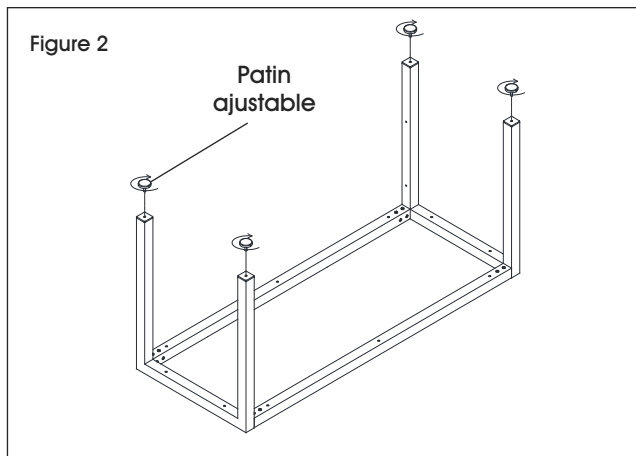

- Pour le montage de la table et du bureau, passez à l'étape 3.
- Pour le montage du bureau en L ou du poste de travail avec bureau en L, passez à l'étape 1 à la page 20.
- Pour le montage du poste de travail dos à dos, passez à l'étape 1 à la page 22.

3. (Optionnel) Si vous avez fait l'achat d'un panneau de séparation, alignez les supports sur les trous situés sur le cadre de support et fixez-les à l'aide de deux boulons M6 x 15 mm. Répétez l'opération pour les autres trous situés du même côté du cadre de support. Insérez le panneau en acrylique dans les supports avec point d'appui. (Voir Figure 3)

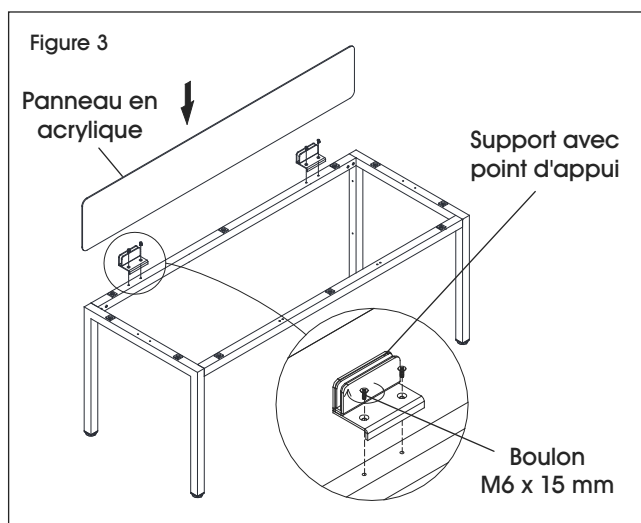

- REMARQUE : Si le panneau de séparation est installé, gardez le cadre debout pour les étapes 4 et 5. (Le panneau de séparation optionnel n'est pas illustré.)

4. Placez la surface de table au sol, face inférieure vers le haut, et posez-y le cadre assemblé en le tournant à l'envers. Alignez les trous de la surface sur ceux du cadre et fixez à l'aide de dix boulons M6 x 65 mm. (Voir Figure 4)

- REMARQUE : Pour les modèles H-8948 et H-8999, fixez la surface et le cadre à l'aide de huit boulons M6 x 60 mm.

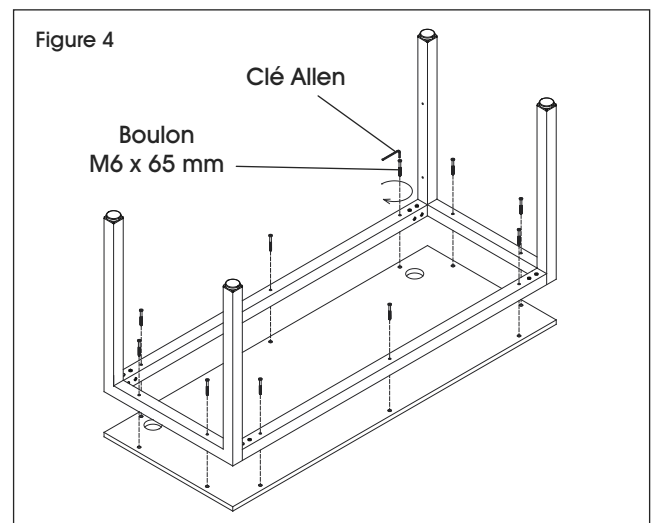

5. Si vous montez un bureau, alignez les trous du panneau cache-jambes sur les trous des pieds et fixez à l'aide de quatre boulons M6 x 12 mm. (Voir Figure 5) Si vous montez une table, appliquez les protections adhésives sur les trous des pieds. (Voir Figure 6)

- REMARQUE : Assurez-vous que le bureau est déjà installé avant de fixer le panneau cache-jambes.

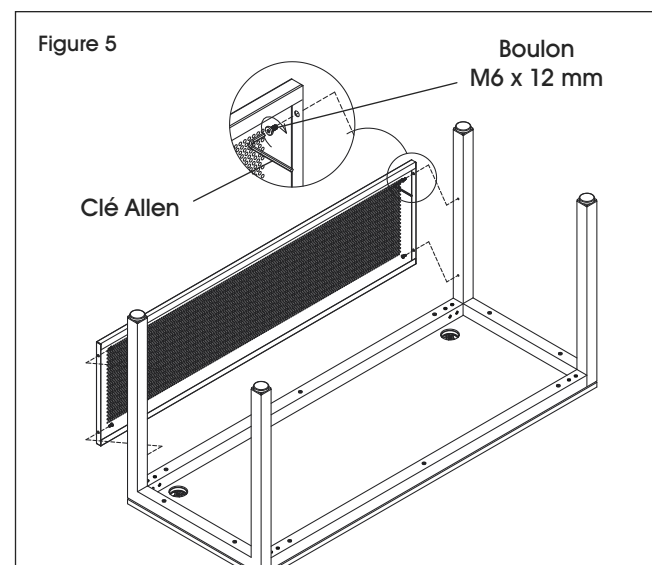

MONTAGE DE LA TABLE ET DU BUREAU SUITE

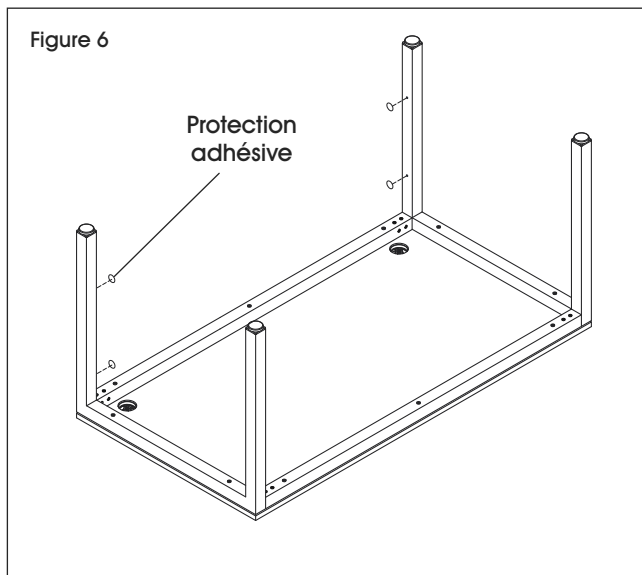

6. Le montage du bureau ou de la table est maintenant complété. À deux, placez avec soin le bureau ou la table sur ses pieds. Insérez les passe-fils noirs ou argentés selon votre gré.

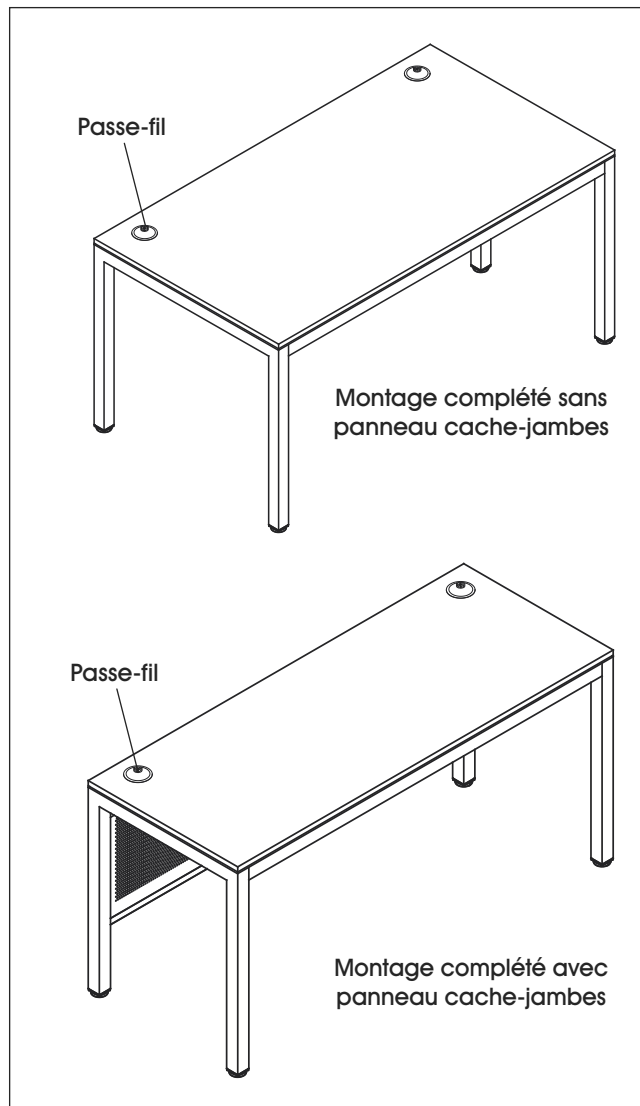

LISTE DES PIÈCES POUR LE MONTAGE DU RETOUR DE BUREAU EN L



Boulon M6 x 12 mm x 8

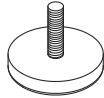

Patin ajustable x 2

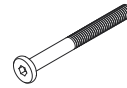

Boulon M6 x 65 mm x 6

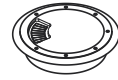

Passe-fil noir x 1

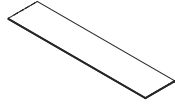

Panneau en acrylique x 1
(optionnel)

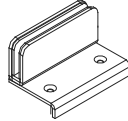

Support avec point
d'appui x 2
(optionnel)



Boulon M6 x 15 mm x 4
(optionnel - 4 pour
H-8220 ou H-8221)



Passe-fil argenté x 1

MONTAGE DU RETOUR DE BUREAU EN L

1. Faites glisser le cadre de support par-dessus la ferrure de pied et fixez-le avec quatre boulons M6 x 12 mm. Répétez l'opération pour la deuxième ferrure de pied. (Voir Figure 7)

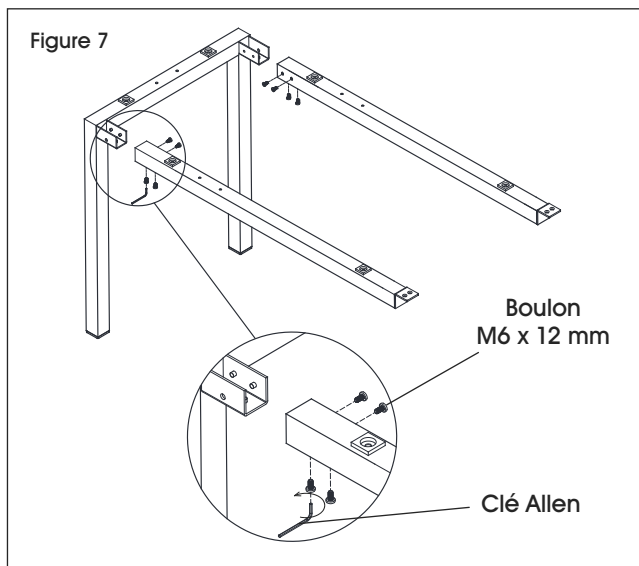

2. Insérez les patins ajustables dans l'extrémité des pieds. (Voir Figure 8)

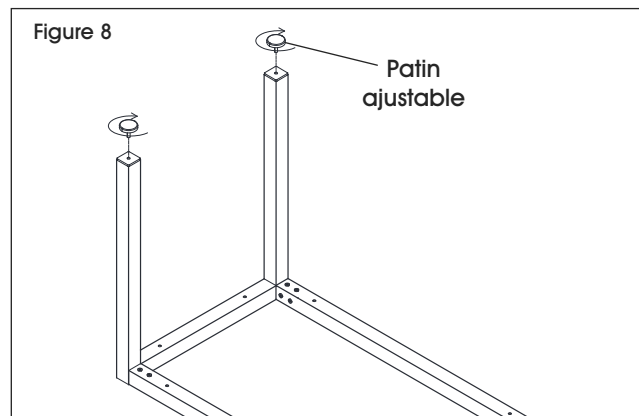

3. Alignez les trous du retour de bureau en L déjà monté sur ceux du cadre du bureau et fixez à l'aide de deux boulons M6 x 15 mm. Répétez l'opération pour l'autre ensemble de trous. (Voir Figure 9)

REMARQUE : Le schéma illustre la configuration en L du côté droit. Pour la configuration en L du côté gauche, rattachez le cadre du retour du côté opposé.

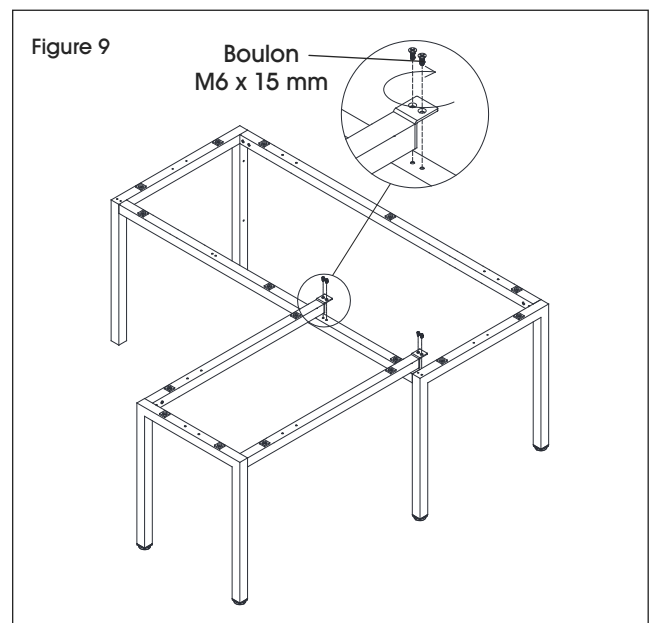

Pour le montage du bureau en L, passez à l'étape 4.

Pour le montage du poste de travail avec bureau en L, passez à l'étape 1 à la page 23.

MONTAGE DU RETOUR DE BUREAU EN L SUITE

4. (Optionnel) Si vous avez fait l'achat de panneaux de séparation, alignez les supports sur les trous situés sur le cadre de support et fixez-les à l'aide de deux boulons M6 x 15 mm. Répétez l'opération du côté opposé du cadre de support. Insérez le panneau en acrylique dans les support avec point d'appui. (Voir Figure 10)

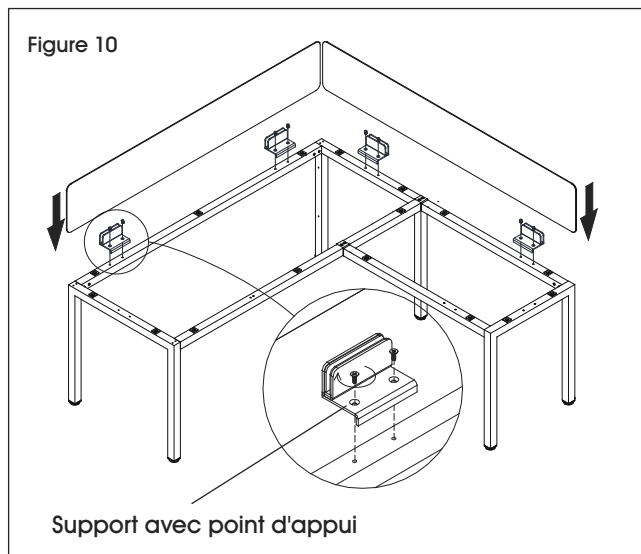

5. Placez les surfaces de table sur le cadre. Alignez les trous des surfaces sur ceux du cadre et fixez à l'aide de seize boulons M6 x 65 mm. (Voir Figure 11)

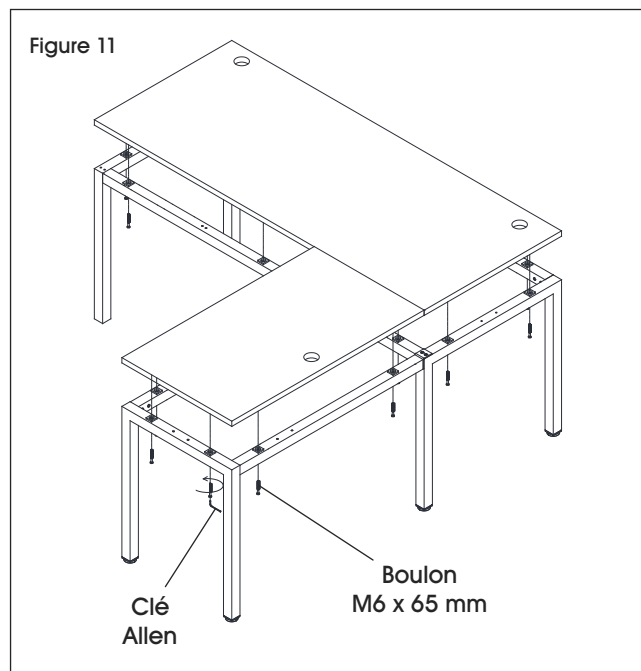

6. Alignez les trous du panneau cache-jambes sur les trous des pieds et fixez à l'aide de quatre boulons M6 x 15 mm. (Voir Figure 12)

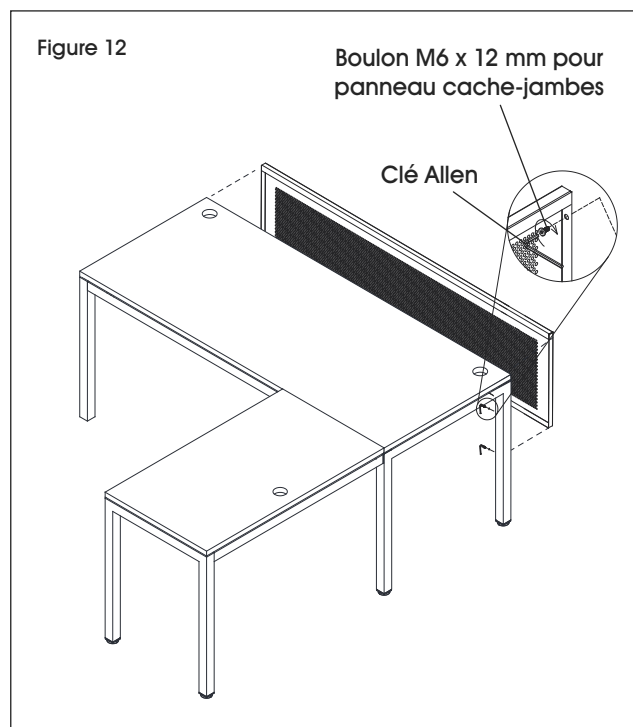

7. Le montage du bureau en L est maintenant complété. Insérez les passe-fils noirs ou argentés selon votre gré.

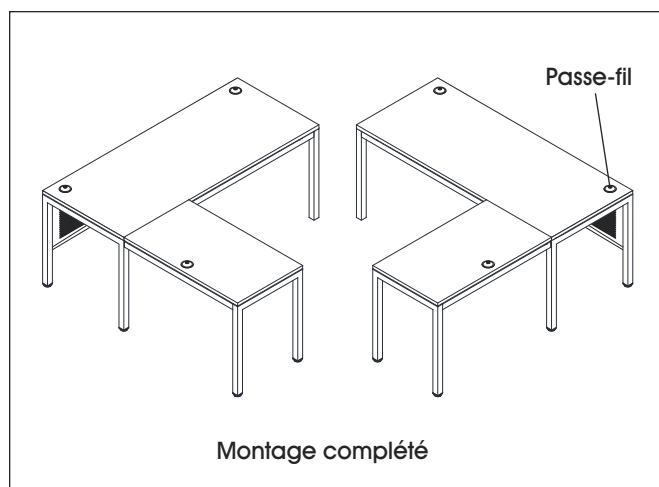

LISTE DES PIÈCES POUR LE POSTE DE TRAVAIL DOS À DOS



Panneau en acrylique x 1

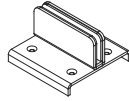

Support double avec point d'appui x 2

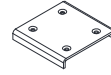

Support double x 2



Boulon M6 x 15 mm x 16

MONTAGE DU POSTE DE TRAVAIL DOS À DOS

- Placez les cadres de bureau ensemble. Alignez le support double avec point d'appui sur les trous situés sur les cadres de support et fixez à l'aide de quatre boulons M6 x 15 mm. Répétez l'opération pour les autres supports doubles avec point d'appui. Insérez le panneau en acrylique dans les supports doubles avec point d'appui. Alignez le support double sur les trous situés sur les cadres de pied et fixez à l'aide de quatre boulons M6 x 15 mm. Répétez l'opération pour les autres supports doubles. (Voir Figure 13)

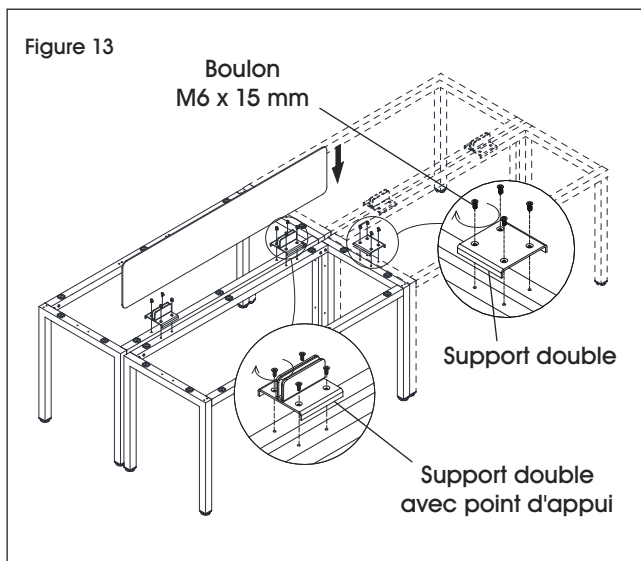

- REMARQUE :** Des ensembles supplémentaires accolés dos à dos peuvent être ajoutés pour créer des configurations plus longues. Pour allonger le poste de travail, fixez les supports doubles à l'extrémité des bureaux et rattachiez les ensembles supplémentaires durant cette étape.

- Placez les surfaces de table sur les cadres. Alignez les trous des surfaces sur ceux des cadres et fixez à l'aide de boulons M6 x 65 mm. (Voir Figure 14)

REMARQUE : Les pièces de la page 17 seront utilisées durant cette étape.

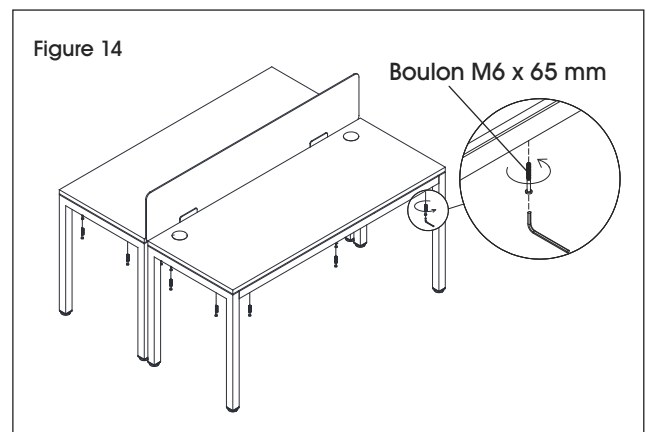

- Alignez les trous du panneau cache-jambes sur les trous des pieds et fixez à l'aide de quatre boulons M6 x 15 mm. Insérez les passe-fils noirs ou argentés selon votre gré. (Voir Figure 15)

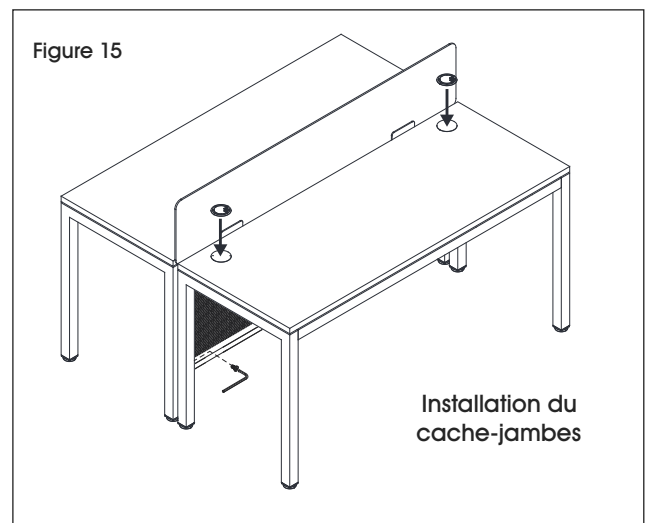

MONTAGE DU POSTE DE TRAVAIL DOS À DOS SUITE

1. Le montage du poste de travail est maintenant complété.

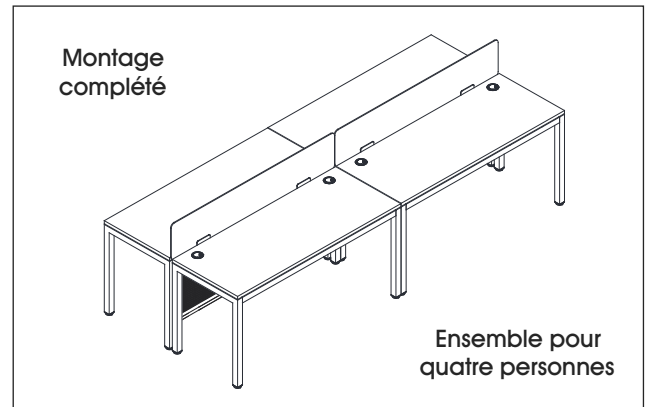
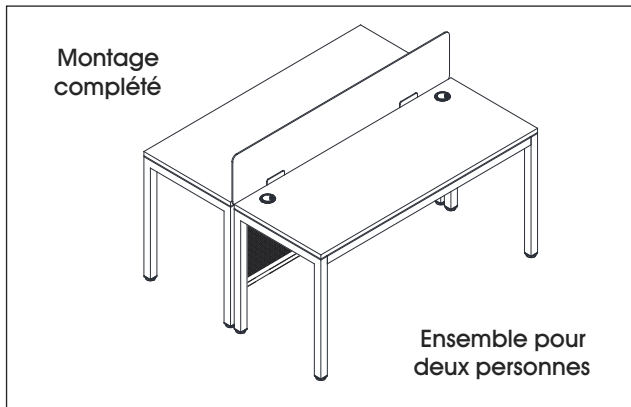

LISTE DES PIÈCES POUR LE POSTE DE TRAVAIL AVEC BUREAU EN L

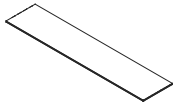

Panneau en acrylique x 1

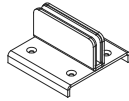

Support double avec point d'appui x 2

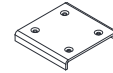

Support double x 2



Boulon M6 x 15 mm x 16

MONTAGE DU POSTE DE TRAVAIL AVEC BUREAU EN L

1. Placez les cadres de bureau ensemble. Alignez le support double avec point d'appui sur les trous situés sur les cadres de support et fixez à l'aide de quatre boulons M6 x 15 mm. Répétez l'opération pour les autres supports doubles avec point d'appui. Insérez le panneau en acrylique dans les supports doubles avec point d'appui. Alignez le support double sur les trous situés sur les cadres de pied et fixez à l'aide de quatre boulons M6 x 15 mm. Répétez l'opération pour les autres supports doubles. (Voir Figure 16)



REMARQUE : Des ensembles supplémentaires de bureaux en L peuvent être ajoutés pour créer des configurations plus longues. Pour allonger le poste de travail, fixez les supports doubles à l'extrémité des bureaux et rattachez les ensembles supplémentaires durant cette étape.

2. Placez les surfaces de table sur les cadres. Alignez les trous des surfaces sur ceux des cadres et fixez à l'aide de boulons M6 x 65 mm. (Voir Figure 17)



REMARQUE : Les pièces de la page 17 seront utilisés durant cette étape.

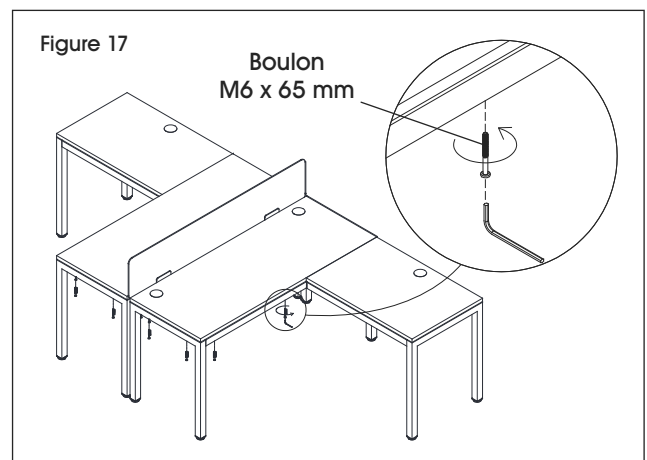
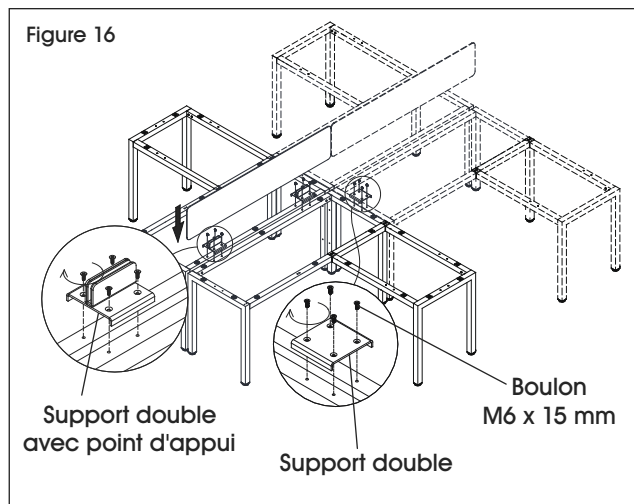

MONTAGE DU POSTE DE TRAVAIL AVEC BUREAU EN L SUITE

3. Fixez avec quatre boulons M6 x 15 mm. Insérez les passe-fils noirs ou argentés selon votre gré. (Voir Figures 18 et 19)

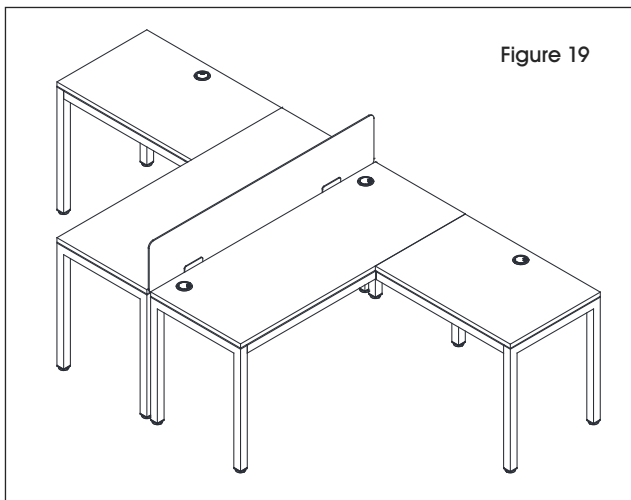
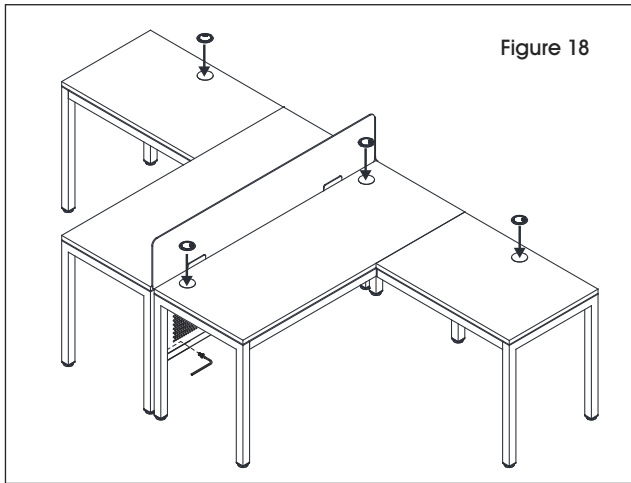

4. Le montage du poste de travail est maintenant complété.

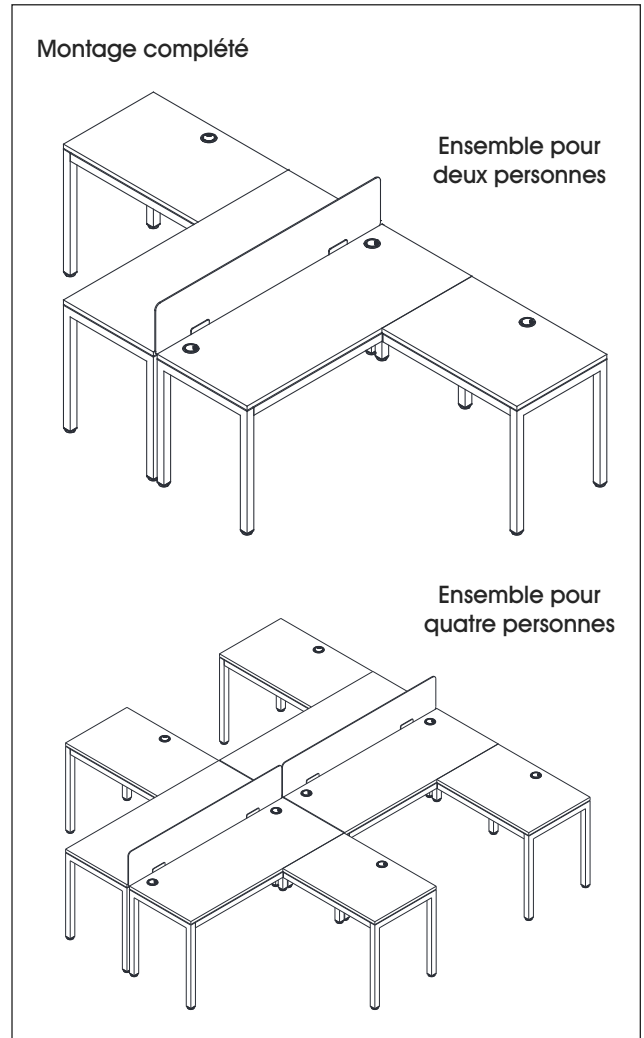

ULINE

1-800-295-5510
uline.ca