

# ULINE H-7787

## COLLABORATION TABLE – DUAL WORKSTATION

1-800-295-5510

uline.com

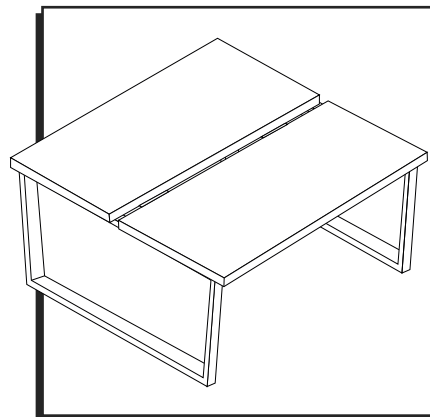

### TOOLS NEEDED



Allen Wrench  
(included)

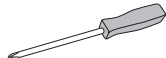

Phillips Screwdriver  
(optional)



Two Person Assembly  
Recommended

### PARTS

A

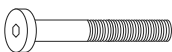

Bolt x 12  
M6 x 45 mm

B

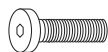

Bolt x 8  
M6 x 15 mm

C

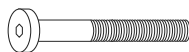

Bolt x 20  
M6 x 60 mm

D



Bolt x 32  
M6 x 12 mm

F



Phillips Head Bolt x 8  
M6 x 15 mm  
(for optional privacy panel)

### ASSEMBLY



**NOTE:** Assemble on smooth, non-marring surface to avoid scratching.



**NOTE:** Use Allen wrench to tighten bolts.



**IMPORTANT!** Check that all parts are included.

1. Fit support rail over corresponding bracket on leg. Use four M6 x 12 mm bolts (D) to secure each side of support rail. Repeat for remaining support rails. (See Figure 1)



**NOTE:** Do not fully tighten bolts until assembly is complete.

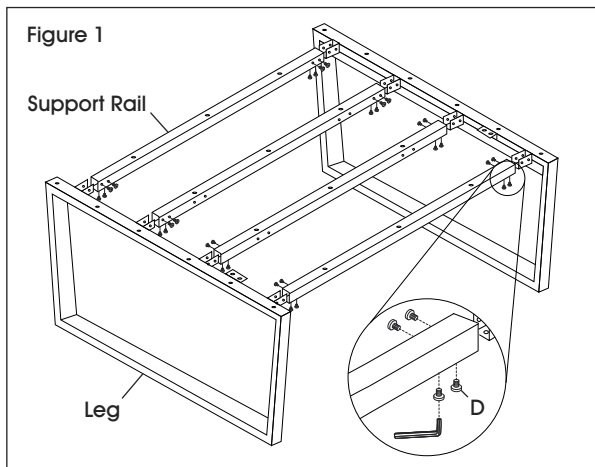

2. Align support spacer with holes in center support rails. Use two M6 x 60 mm bolts (C) to secure each end. Repeat for remaining support spacer. (See Figure 2)

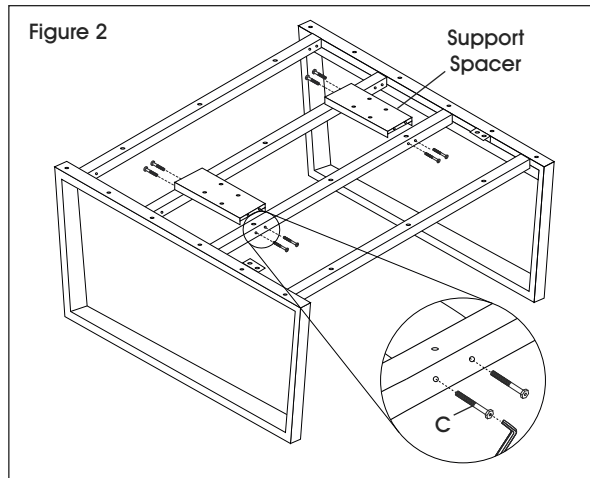

For optional privacy panel, continue to Step 3. Otherwise, skip to Step 5.

## ASSEMBLY CONTINUED

- Align bracket with holes in support spacer. Use four M6 x 15 mm bolts (F) to secure. Repeat for remaining bracket. (See Figure 3)

 **NOTE:** For optional privacy panel brackets, use Phillips screwdriver to tighten bolts.

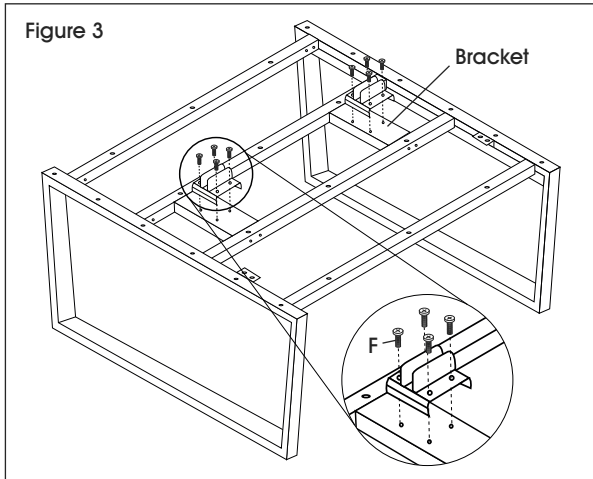

- With two people, insert privacy panel into bracket. (See Figure 4)

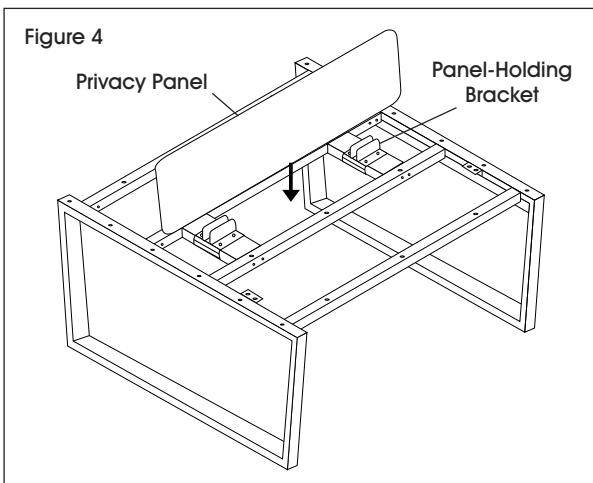

- With two people, place tabletops on assembled frame. Align tabletops with holes on legs. (See Figure 5)

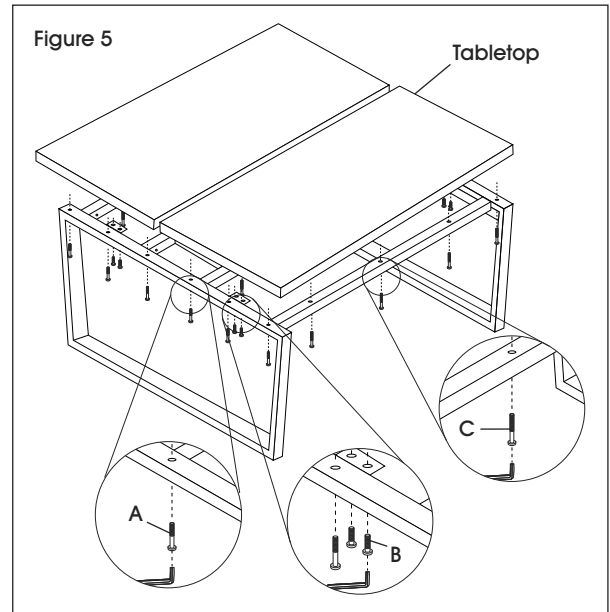

- Attach tabletops to legs using six M6 x 45 mm bolts (A) per leg. (See Figure 5)
- Attach tabletops to leg brackets using two M6 x 15 mm bolts (B) per bracket. (See Figure 5)
- Attach tabletops to support rails using three M6 x 60 mm bolts (C) per rail. (See Figure 5)
- Tighten bolts (D) installed in Step 1.

**ULINE**

1-800-295-5510  
uline.com

**ULINE** H-7787

800-295-5510  
uline.mx

# MESA PARA TRABAJO EN EQUIPO – ESTACIÓN DE TRABAJO DOBLE

## HERRAMIENTAS NECESARIAS



Llave Allen  
(incluida)

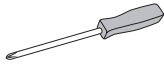

Desarmador de  
Cruz  
(opcional)



Se recomienda Armar  
Entre Dos Personas

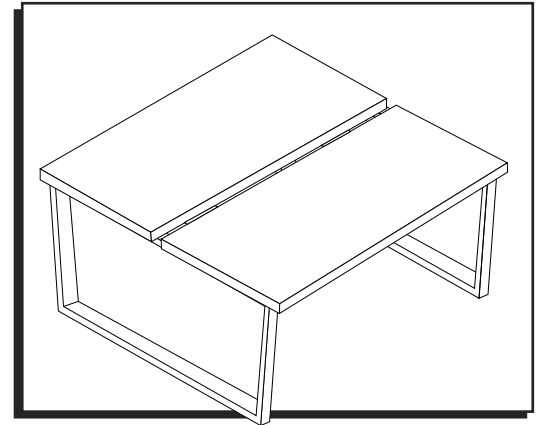

## PARTES

A

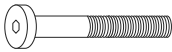

12 Pernos  
M6 x 45 mm

B

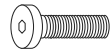

8 Pernos  
M6 x 15 mm

C

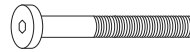

20 Pernos  
M6 x 60 mm

D



32 Pernos  
M6 x 12 mm

F



8 Pernos de Cabeza de Cruz  
M6 x 15 mm (para panel de  
privacidad opcional)

## ENSAMBLE



**NOTA:** Ensamble sobre una superficie lisa que no deje marcas para evitar rayones.



**NOTA:** Utilice la llave Allen para apretar todos los tornillos.



**¡¡IMPORTANTE!** Verifique que todas las partes estén incluidas.

1. Acomode el riel de soporte sobre su soporte correspondiente en la pata. Use cuatro pernos M6 x 12 mm (D) para asegurar cada lado del riel de soporte. Repita la operación con los rieles de soporte restantes. (Vea Diagrama 1)



**NOTA:** No apriete los pernos por completo hasta que termine de ensamblar.

2. Alinee el espaciador de soporte con los orificios de los rieles de soporte en el centro. Use dos pernos de M6 x 60 mm (C) para asegurar cada extremo. Repita la operación con el espaciador de soporte restante. (Vea Diagrama 2)

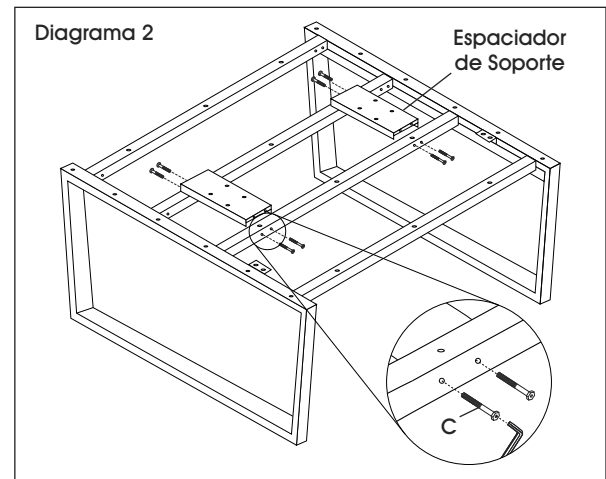
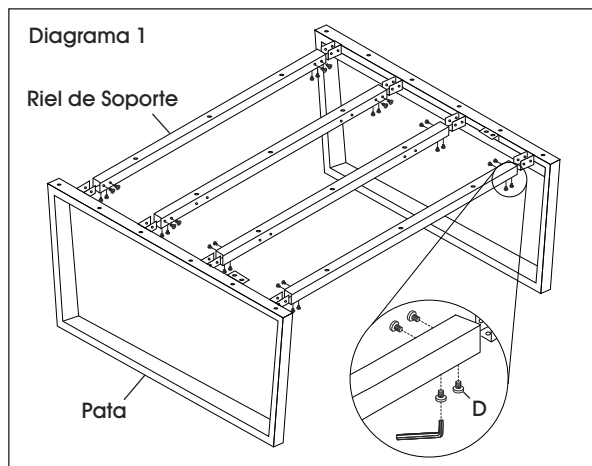

**ALTO** Para el panel de privacidad opcional, proceda al Paso 3. De lo contrario, continúe al Paso 5.

## CONTINUACIÓN DEL ENSAMBLE

3. Alinee el soporte con los orificios del espaciador de soporte. Use cuatro pernos de M6 x 15 mm (F) para asegurarlo. Repita la operación con el soporte restante. (Vea Diagrama 3)

 **NOTA:** Para los soportes del panel de privacidad opcionales, use un desarmador de cruz para apretar los pernos.

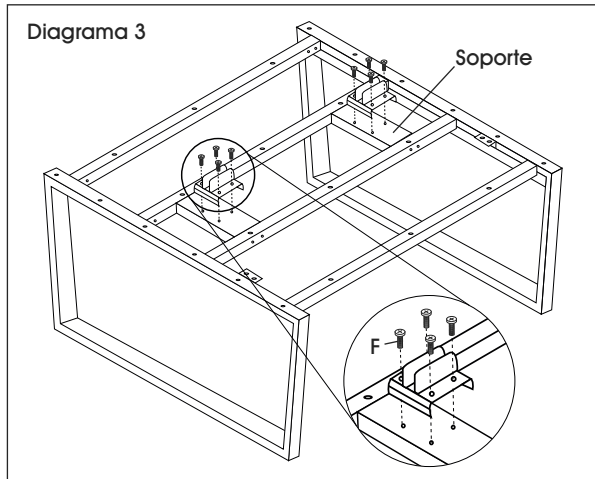

4. Entre dos personas, inserten el panel de privacidad en el soporte. (Vea Diagrama 4)

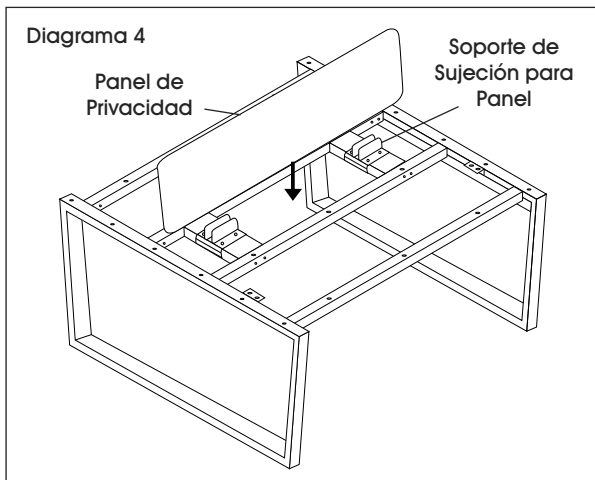

5. Entre dos personas, coloquen las cubiertas en el armazón ensamblado. Alinee las cubiertas con los orificios de las patas. (Vea Diagrama 5)

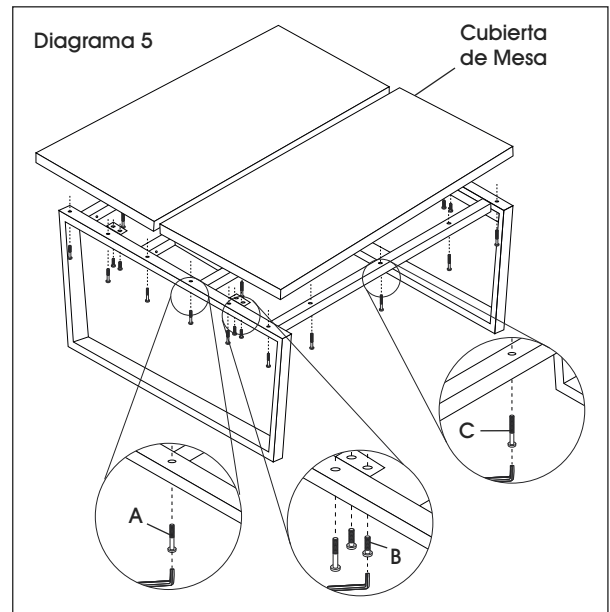

6. Fije las cubiertas a las patas usando seis pernos M6 x 45 mm (A) por pata. (Vea Diagrama 5)
7. Fije las cubiertas a los soportes de las patas usando dos pernos M6 x 15 mm (B) por soporte. (Vea Diagrama 5)
8. Asegure las cubiertas a los rieles de soporte usando tres pernos M6 x 60 mm (C) por riel. (Vea Diagrama 5)
9. Apriete los pernos (D) instalados en el Paso 1.

**ULINE**

800-295-5510  
uline.mx

**ULINE H-7787**

# TABLE DE COLLABORATION – POSTE DE TRAVAIL DOUBLE

1-800-295-5510  
uline.ca

Para Español, vea páginas 3-4.  
Pour le français, consulter les pages 5-6.

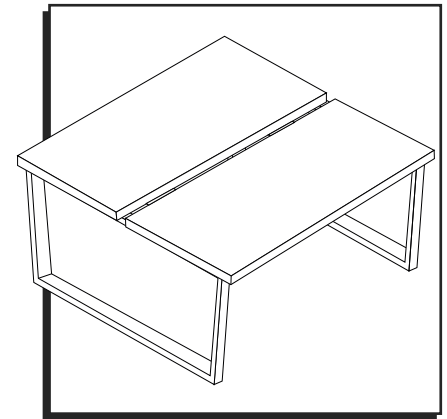

## OUTILS REQUIS



Clé Allen  
(inclus)

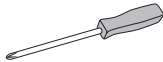

Tournevis  
cruziforme  
(optionnel)



Montage à deux  
personnes recommandé

## PIÈCES

A

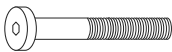

Boulon x 12  
M6 x 45 mm

B

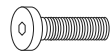

Boulon x 8  
M6 x 15 mm

C

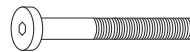

Boulon x 20  
M6 x 60 mm

D



Boulon x 32  
M6 x 12 mm

F



Boulon à tête cruziforme x 8  
M6 x 15 mm (pour panneau  
de séparation optionnel)

## MONTAGE



**REMARQUE :** Montez la table sur une surface lisse qui ne marque pas afin d'éviter les rayures.



**REMARQUE:** Utilisez une clé Allen pour serrer les boulons.



**IMPORTANT!** Vérifiez que toutes les pièces sont incluses.

1. Placez la barre de soutien sur le support correspondant situé sur le pied. Utilisez quatre boulons M6 x 12 mm (D) pour fixer chaque côté de la barre de soutien. Répétez l'opération pour les barres de soutien restantes. (Voir Figure 1)



**REMARQUE :** Attendez d'avoir terminé le montage pour serrer complètement les boulons.

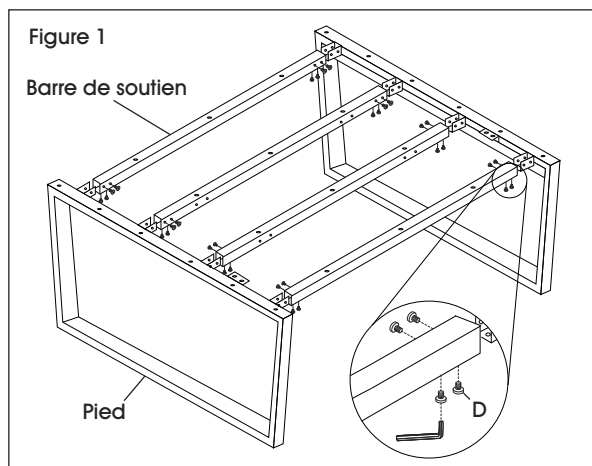

2. Alignez l'entretoise de soutien avec les trous situés dans les barres de soutien centrales. Utilisez quatre boulons M6 x 60 mm (C) pour fixer chaque extrémité. Répétez l'opération pour l'entretoise de soutien restante. (Voir Figure 2)

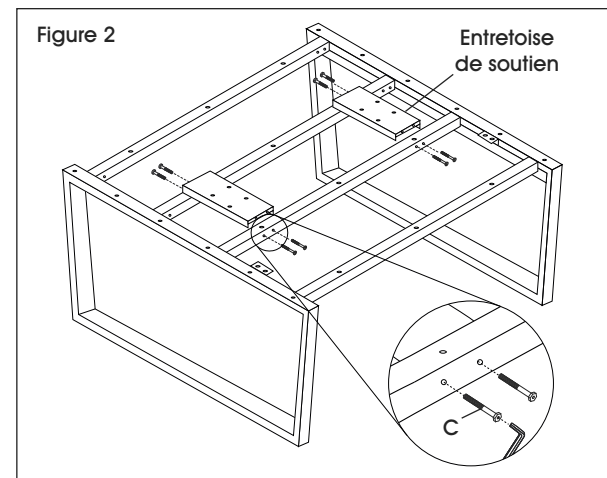

**ARRÊT** Pour le panneau de séparation optionnel, passez à l'étape 3. Sinon, passez à l'étape 5.

## MONTAGE SUITE

- Alignez un support sur les trous de l'entretoise de soutien. Fixez-le avec quatre boulons M6 x 15 mm (F). Répétez cette opération pour le support restant. (Voir Figure 3)

 **REMARQUE :** Pour les supports du panneau de séparation optionnel, utilisez un tournevis cruciforme pour serrer les boulons.

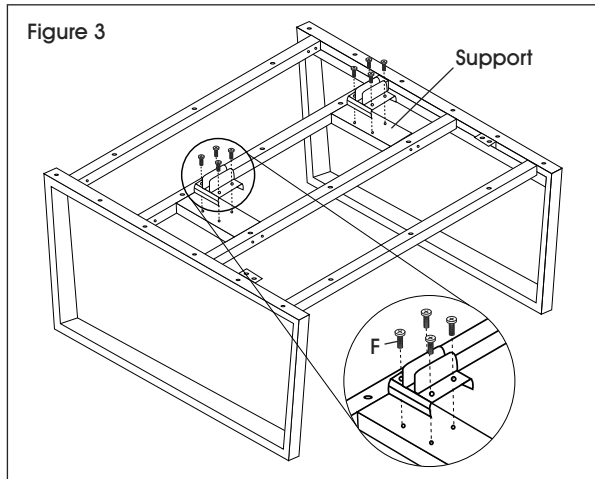

- À deux, insérez le panneau de séparation dans le support. (Voir Figure 4)

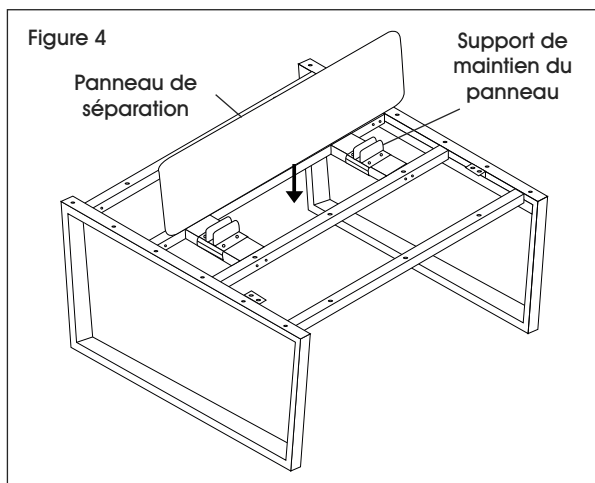

- À deux, placez les surfaces de table sur le cadre assemblé. Alignez les surfaces de table sur les trous des pieds. (Voir Figure 5)

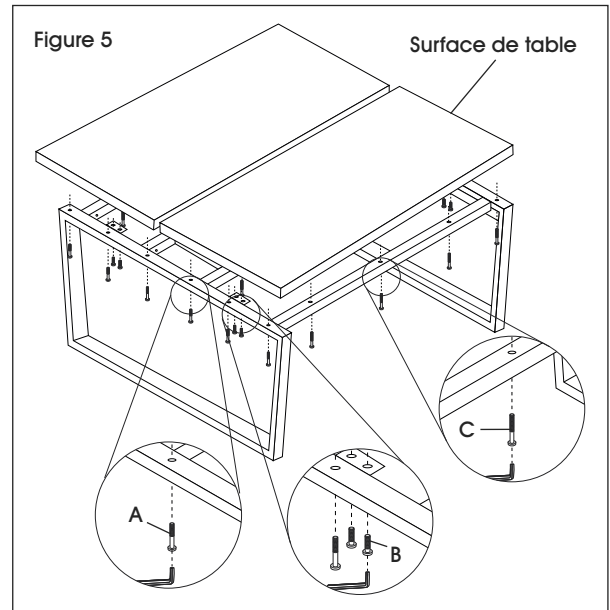

- Fixez les surfaces de table aux pieds avec six boulons M6 x 45 mm (A) par pied. (Voir Figure 5)
- Fixez les surfaces de table aux supports des pieds avec deux boulons M6 x 15 mm (B) par support. (Voir Figure 5)
- Fixez les surfaces de table aux barres de soutien avec trois boulons M6 x 60 mm (C) par barre. (Voir Figure 5)
- Serrez les boulons (D) insérés à la première étape.

**ULINE**

1-800-295-5510  
uline.ca