

ULINE H-7941 4' RECYCLED PLASTIC BENCH WITH BACK

1-800-295-5510
uline.com

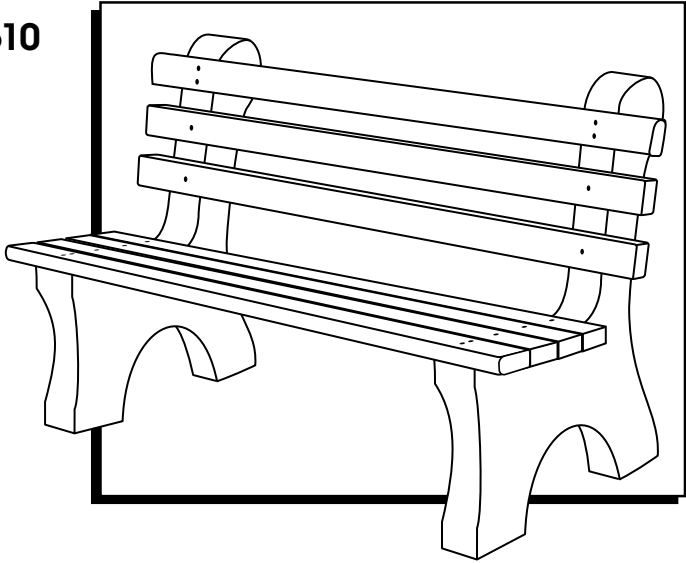

TOOLS NEEDED



Power Drill



7/16" Socket Bit

PARTS

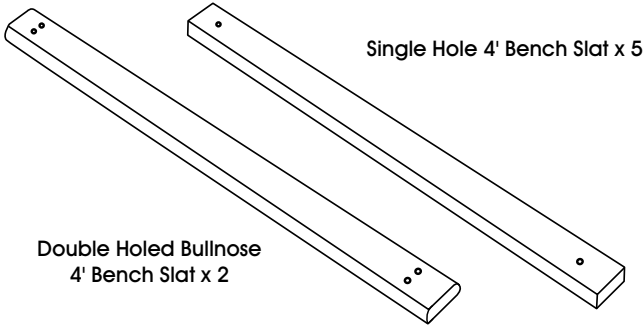

Double Holed Bullnose
4' Bench Slat x 2

Single Hole 4' Bench Slat x 5

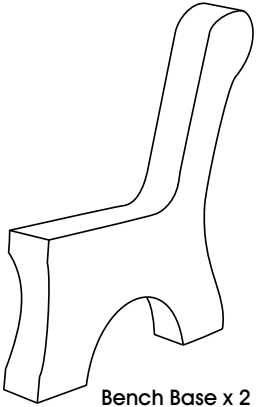

Bench Base x 2



3 1/2" Lag Screws x 18



Washers x 18

ASSEMBLY

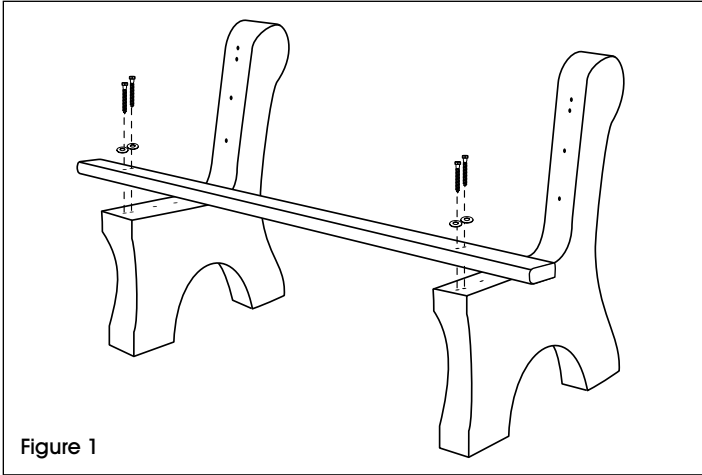

Figure 1

 **NOTE:** It is important to keep screws loose throughout assembly. Tighten during step 7.

1. Verify all parts are present before beginning.
2. Place the two bench bases on a flat, level surface.
3. Align a double holed bullnose bench slat on the front set of pre-drilled holes on the bench base seat. Loosely attach bench slat to the bench bases with the 3 1/2" lag screws and washers using the power drill and 7/16" socket bit (will tighten later in step 7). (See Figure 1)

ASSEMBLY CONTINUED

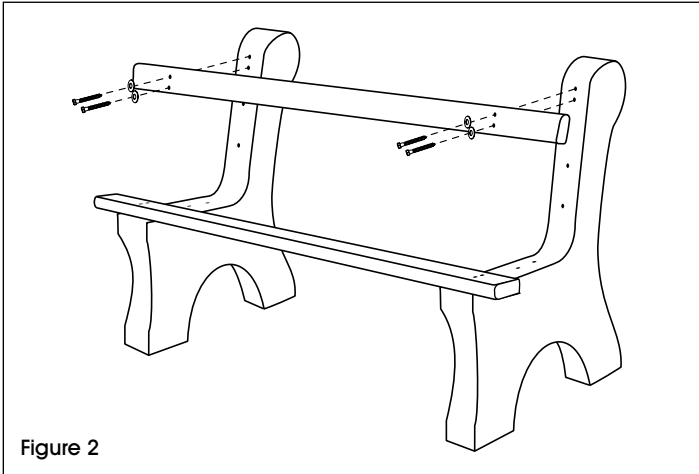

Figure 2

4. Align the second double holed bullnose bench slat on the top set of pre-drilled holes on the bench base backrest. Loosely attach double holed bullnose bench slat to the bench bases with the 3/2" lag screws and washers using the power drill and 7/16" socket bit (will tighten later in step 7). (See Figure 2)

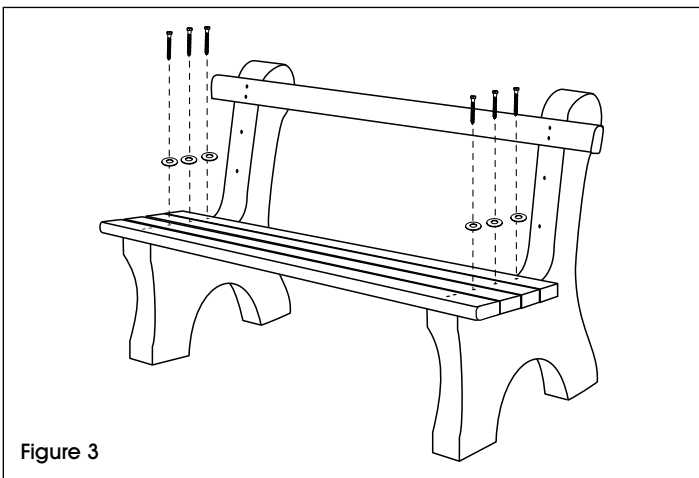

Figure 3

5. Align three single hole bench slats on the pre-drilled holes of the bench base seat. Loosely attach the single hole bench slats with the 3/2" lag screws and washers using the power drill and 7/16" socket bit (will tighten later in step 7). (See Figure 3)

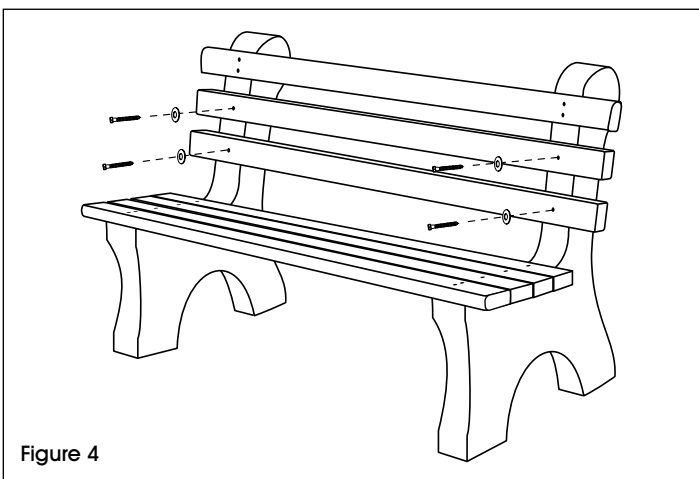

Figure 4

6. Align the remaining two single hole bench slats on the pre-drilled holes of the bench base backrest. Loosely attach the single hole bench slats with the 3/2" lag screws and washers using the power drill and 7/16" socket bit (will tighten later in step 7). (See Figure 4)
7. Make sure the bench is square and tighten all lag screws.



NOTE: H-2565 Mounting hardware sold separately.

ULINE

1-800-295-5510

uline.com

ULINE H-7941

BANCA DE PLÁSTICO RECICLADO DE 4' CON RESPALDO

800-295-5510
uline.mx

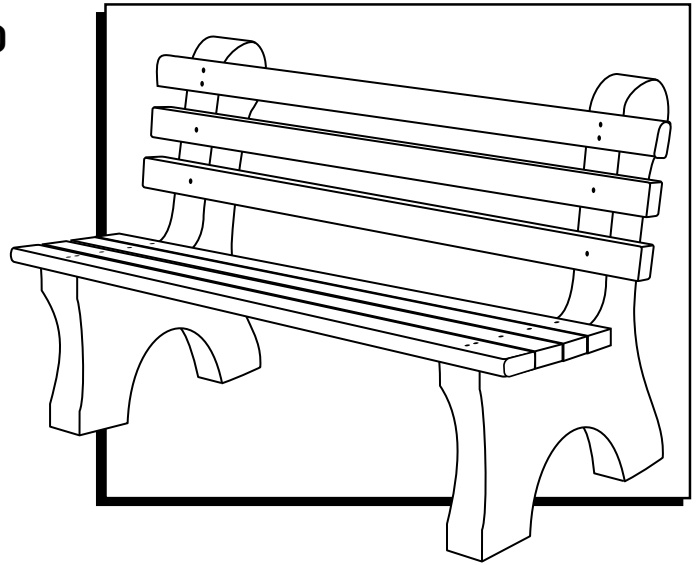

HERRAMIENTAS NECESARIAS



Taladro Eléctrico



Dado de 7/16"

PARTES

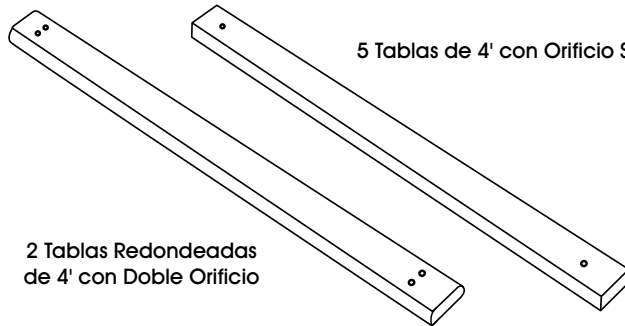

5 Tablas de 4' con Orificio Sencillo

2 Tablas Redondeadas
de 4' con Doble Orificio

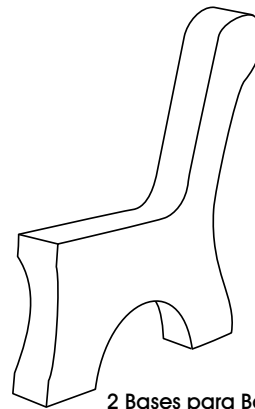

2 Bases para Banca



18 Tornillos Tirafondo de 3/2"



18 Rondanas

ENSAMBLE



Diagrama 1



NOTA: Es importante mantener los tornillos aflojados durante el ensamble. Apriételos en el paso 7.

1. Verifique que estén todas las partes antes de comenzar.
2. Coloque las dos bases de la banca sobre una superficie plana y nivelada.
3. Alinee una tabla redondeada con doble orificio en el set de orificios preperforados frontales en la base del asiento de la banca. Acople ligeramente las tablas con orificio sencillo a las bases con los tornillos tirafondo de 3/2" y rondanas usando el taladro y el dado de 7/16" (se apretarán más adelante en el paso 7). (Vea Diagrama 1)

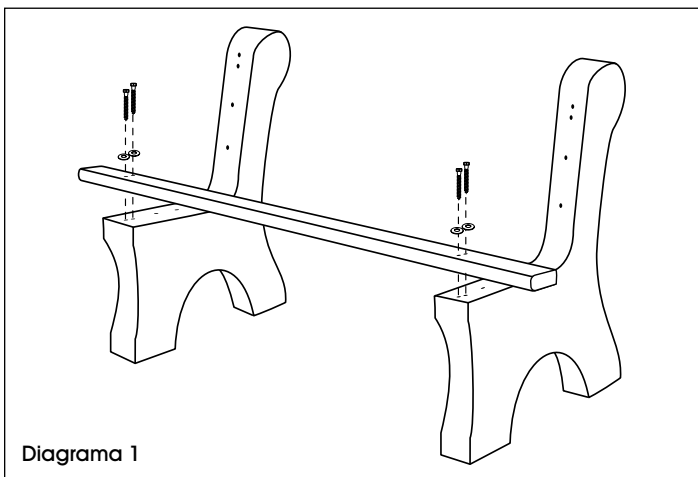
CONTINUACIÓN DE ENSAMBLE



Diagrama 2

4. Alinee la segunda tabla redondeada con doble orificio en el set de orificios preperforados en la base del respaldo de la banca. Acople ligeramente las tablas con doble orificio con los tornillos tirafondo de 3½" y rondanas usando el taladro y el dado de 7/16" (se apretarán más adelante en el paso 7). (Vea Diagrama 2)

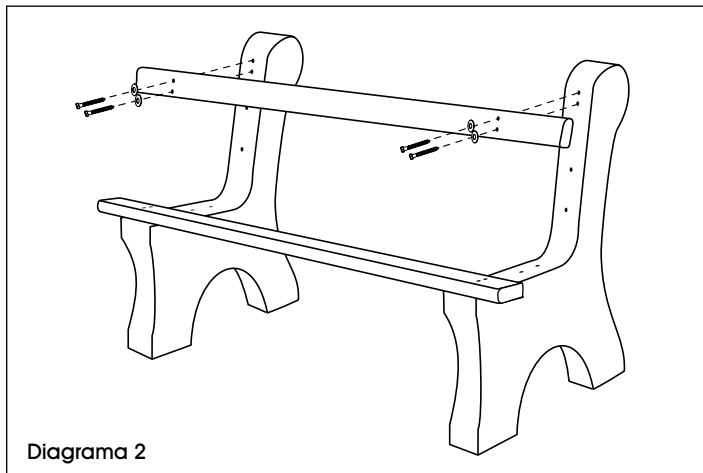

Diagrama 3

5. Alinee tres tablas con orificio sencillo en el set de orificios preperforados de la base del asiento de la banca. Acople ligeramente las tablas con orificio sencillo con los tornillos tirafondo de 3½" y rondanas usando el taladro y el dado de 7/16" (se apretarán más adelante en el paso 7). (Vea Diagrama 3)

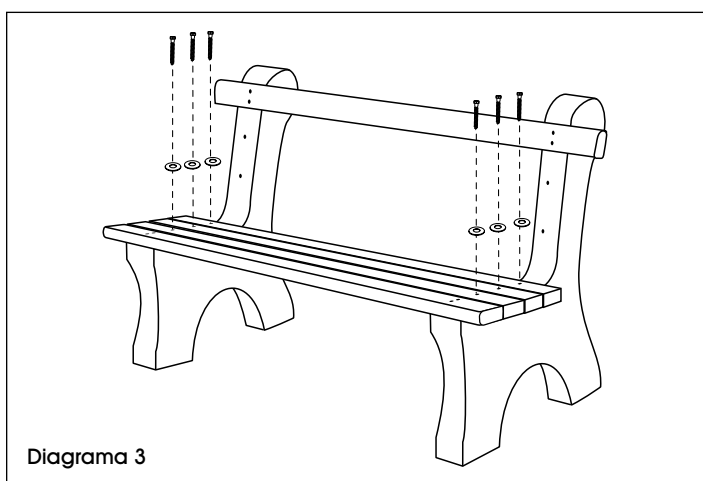

Diagrama 4

6. Alinee las tablas con orificio sencillo en los orificios preperforados de la base del respaldo de la banca. Acople ligeramente las tablas con orificio sencillo a las bases con los tornillos tirafondo de 3½" y rondanas usando el taladro y el dado de 7/16" (se apretarán más adelante en el paso 7). (Vea Diagrama 4)
7. Asegúrese de que la banca esté en escuadra y apriete todos los tornillos tirafondo.

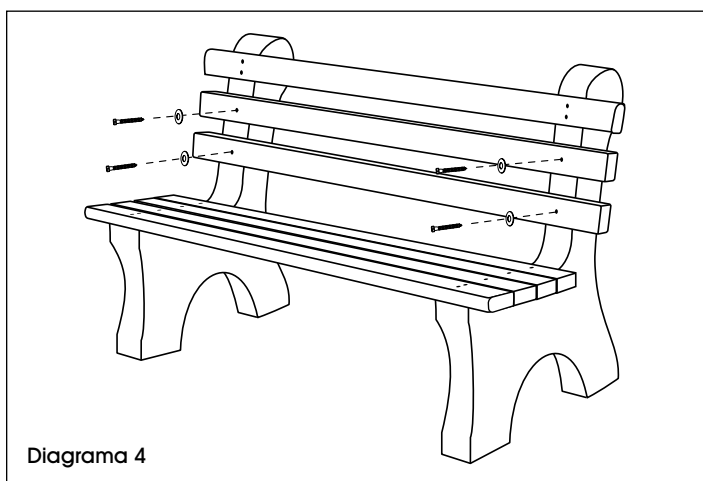

NOTA: La tornillería de instalación H-2565 se vende por separado.

ULINE

800-295-5510
uline.mx

ULINE H-7941

**BANC AVEC DOSSIER
EN PLASTIQUE
RECYCLÉ – 4 PI**

1-800-295-5510

uline.ca

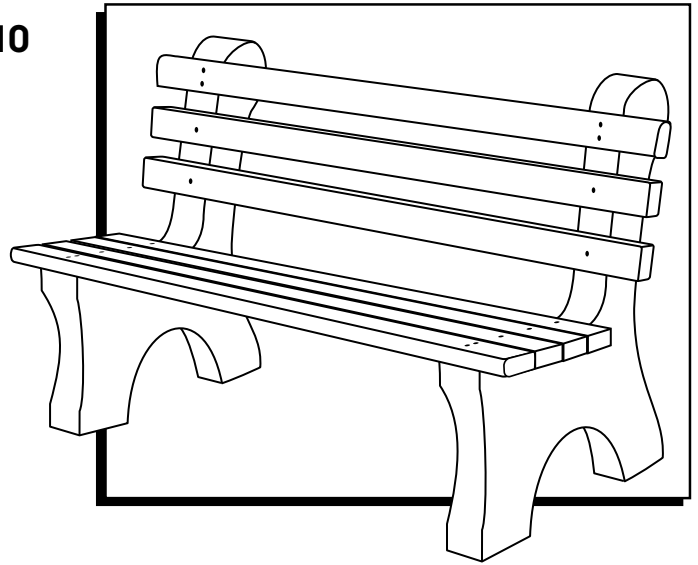

OUTILS REQUIS



Perceuse électrique



Douille tournevis
de 7/16 po

PIÈCES

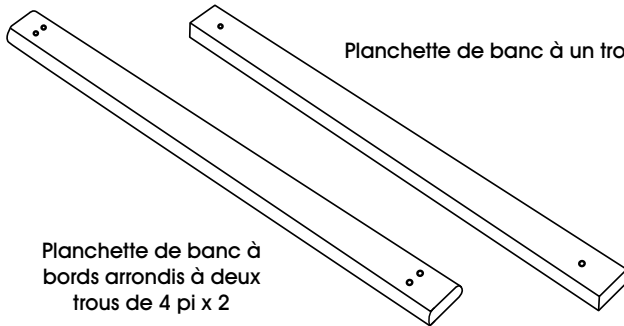

Planchette de banc à
bords arrondis à deux
trous de 4 pi x 2

Planchette de banc à un trou de 4 pi x 5

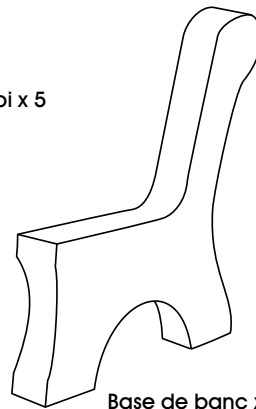

Base de banc x 2



Vis tire-fond de 3 ½ po x 18



Rondelle x 18

MONTAGE

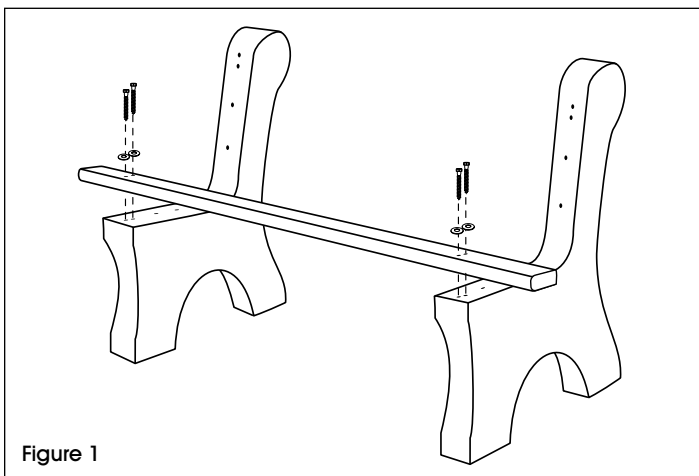

Figure 1



REMARQUE : Il est important de garder les vis desserrées pendant le montage. Serrez à l'étape 7.

1. Assurez-vous que toutes les pièces sont présentes avant de commencer.
2. Placez les deux bases de banc sur une surface plane et nivelée.
3. Alignez une des planchettes à bords arrondis sur les deux trous prépercés au devant de la partie siège des bases de banc. Fixez-la lâchement aux bases de banc à l'aide des vis tire-fonds de 3 ½ po, des rondelles, de la perceuse et de la douille tournevis de 7/16 po (Serrez les vis plus tard à l'étape 7). (Voir Figure 1)

MONTAGE SUITE

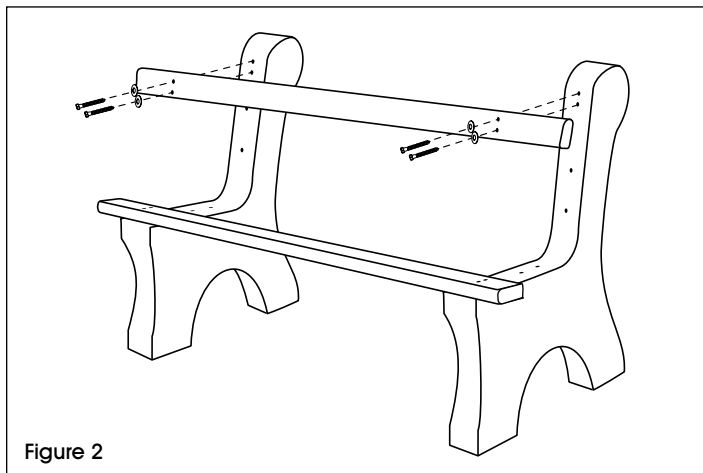

Figure 2

4. Alignez l'autre planchette à bords arrondis sur les deux trous prépercés du haut de la partie dossier des bases de banc. Fixez-la lâchement aux bases de banc à l'aide des vis tire-fonds de 3 ½ po, des rondelles, de la perceuse et de la douille tournevis de 7/16 po (Serrez les vis plus tard à l'étape 7). (Voir Figure 2)

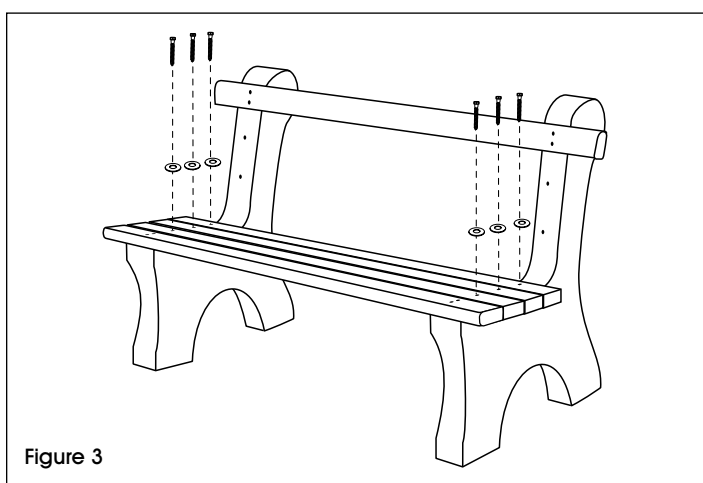

Figure 3

5. Alignez trois planchettes à un trou sur les trous prépercés de la partie siège des bases de banc. Fixez-les lâchement à l'aide des vis tire-fonds de 3 ½ po, des rondelles, de la perceuse et de la douille tournevis de 7/16 po (Serrez les vis plus tard à l'étape 7). (Voir Figure 3)

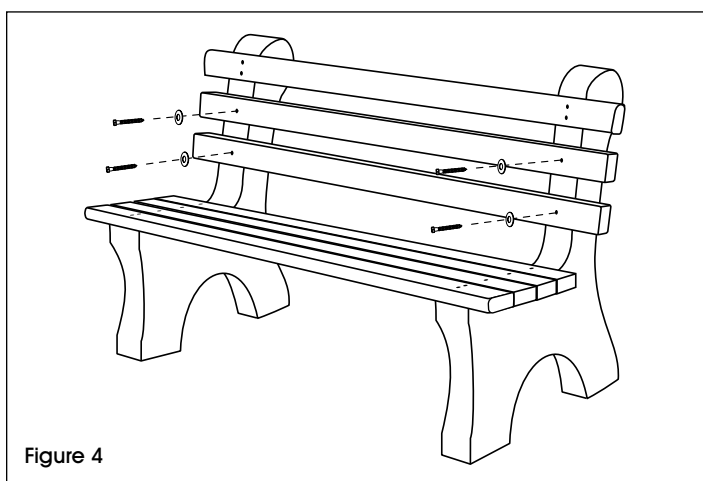

Figure 4

6. Alignez les deux planchettes à un trou restantes sur les trous prépercés de la partie dossier des bases de banc. Fixez-les lâchement à l'aide des vis tire-fonds de 3 ½ po, des rondelles, de la perceuse et de la douille tournevis de 7/16 po (Serrez les vis plus tard à l'étape 7). (Voir Figure 4)
7. Assurez-vous que le banc est bien cadré, puis serrez toutes les vis tire-fonds.



REMARQUE : Le matériel d'installation H-2565 est vendu séparément.

ULINE

1-800-295-5510
uline.ca