

PARTS



Hose



Nozzle



Female IBC Fitting

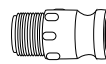

Male Nozzle Fitting



Hanging Bracket



Plumber's Tape

ASSEMBLY

1. Unscrew 2" IBC bung opening and screw on female IBC Fitting. (See Figure 1)

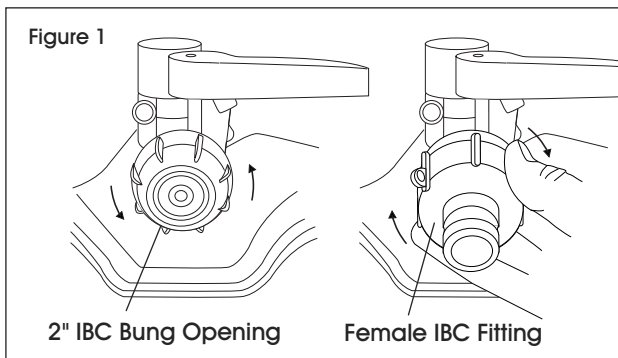

2. Connect one end of hose to female IBC fitting. (See Figure 2)

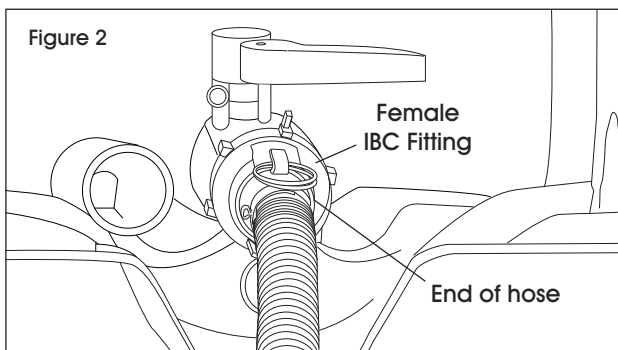

3. Apply plumber's tape on the threading of the male nozzle fitting and screw into bottom of the nozzle. (See Figure 3)

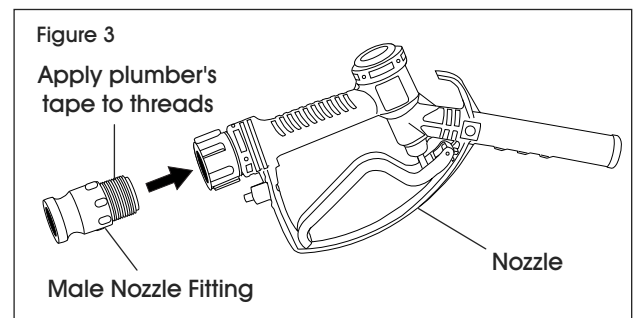

4. Connect the male nozzle fitting to the opposite end of the hose. (See Figure 4)

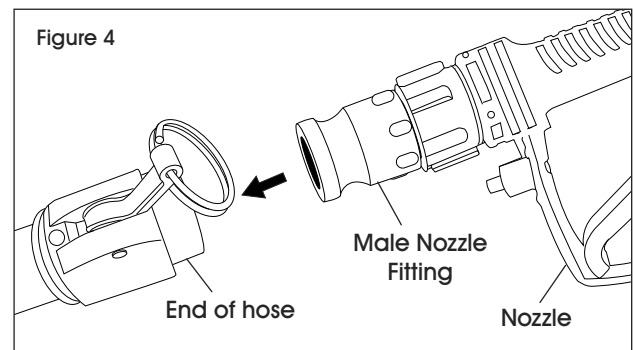

ASSEMBLY CONTINUED

5. Attach hanging bracket to IBC Cage. (See Figures 5-6)

Figure 5

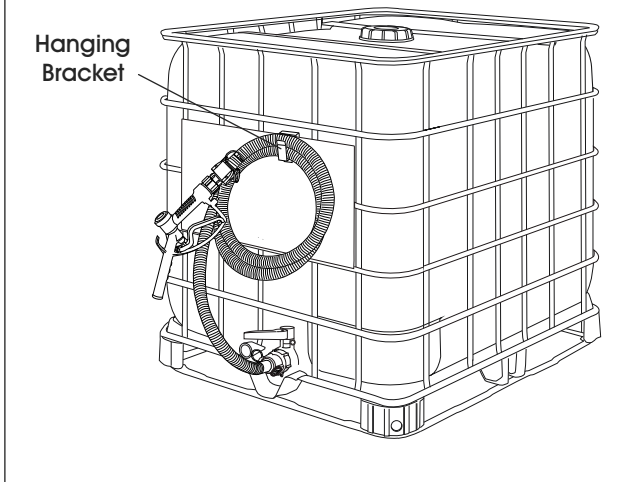
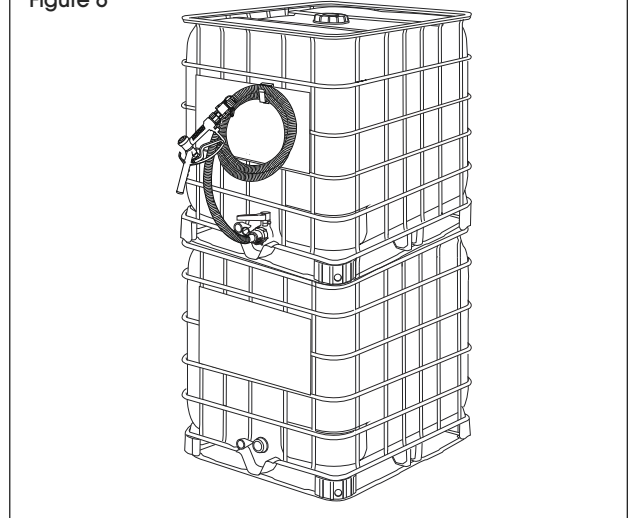

Figure 6



OPERATION

1. Once IBC hose is fully assembled, turn the bottom valve to the on position. (See Figure 7)
2. Pull handle trigger to dispense IBC contents. Nozzle trigger can be locked in the dispensing position by pressing down on the nozzle button. (See Figure 8)

Figure 7

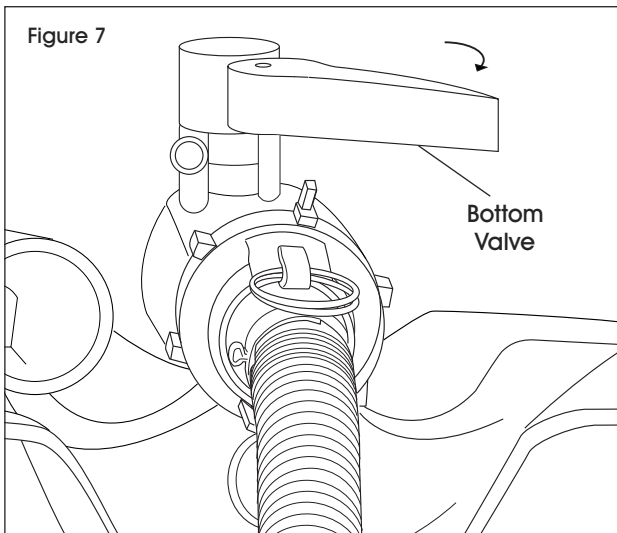
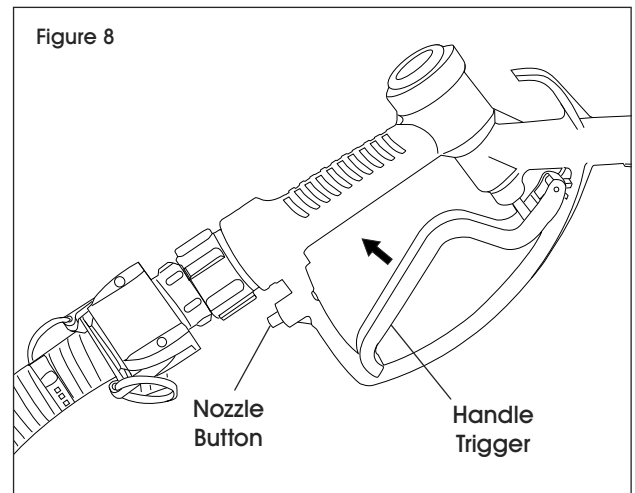





Figure 8



-  **NOTE:** Recommend using IBC hose with top IBC when stacked two high.
-  **NOTE:** Always store IBC hose on hanging bracket when not in use.
-  **NOTE:** Only use IBC hose with liquids compatible with IBC hose materials.

ULINE

1-800-295-5510
uline.com

ULINE H-8027
MANGUERA PARA IBC

800-295-5510
 uline.mx

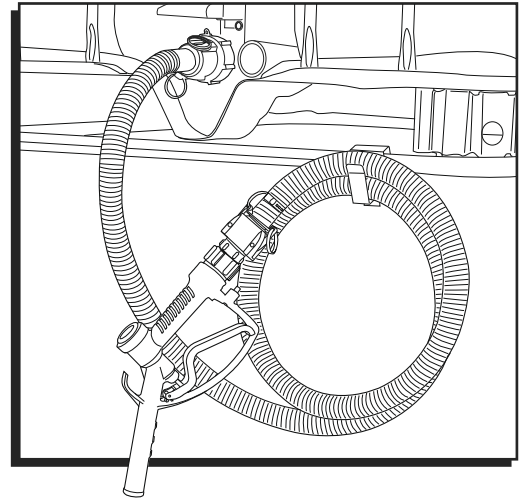

PARTES



Manguera



Boquilla



Extremo Hembra del IBC

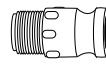

Extremo Macho de la Boquilla



Soporte para Colgar



Cinta para Plomeros

ENSAMBLE

1. Desatornille la abertura del tapón de 2" del IBC y atornille el extremo hembra del IBC. (Vea Diagrama 1)

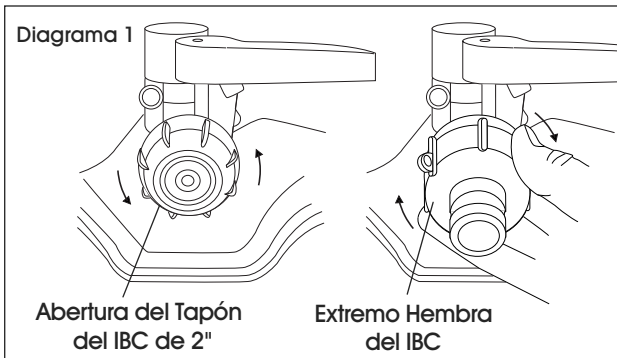

2. Conecte un extremo de la manguera al extremo hembra del IBC. (Vea Diagrama 2)

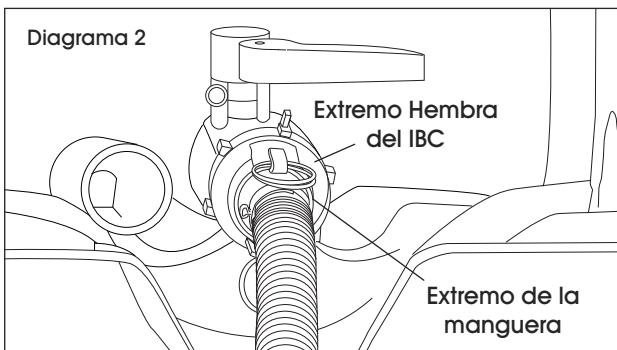

3. Aplique cinta para plomeros en la rosca del extremo macho de la boquilla y enrósquelo en la parte inferior de la boquilla. (Vea Diagrama 3)

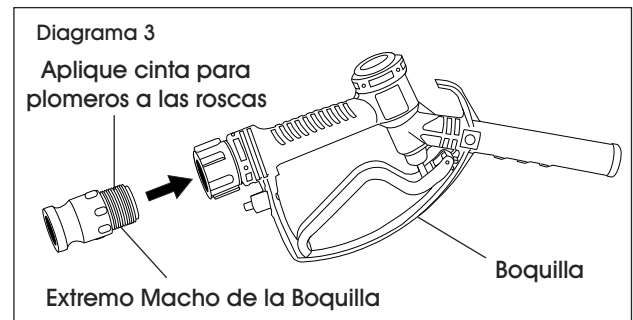

4. Conecte el extremo macho de la boquilla al extremo opuesto de la manguera. (Vea Diagrama 4)

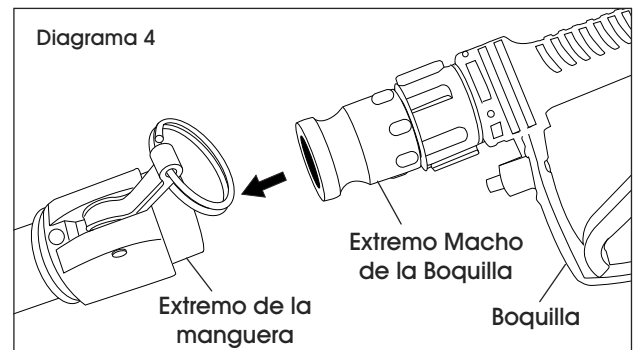

CONTINUACIÓN DEL ENSAMBLE

5. Fije el soporte para colgar a la jaula del IBC. (Vea Diagramas 5-6)

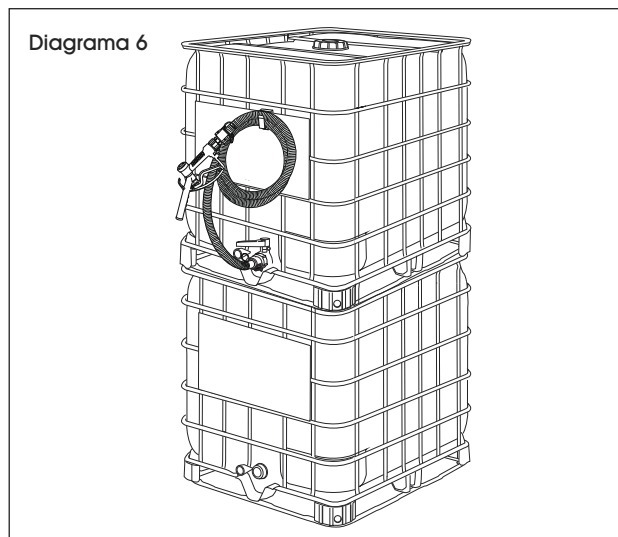
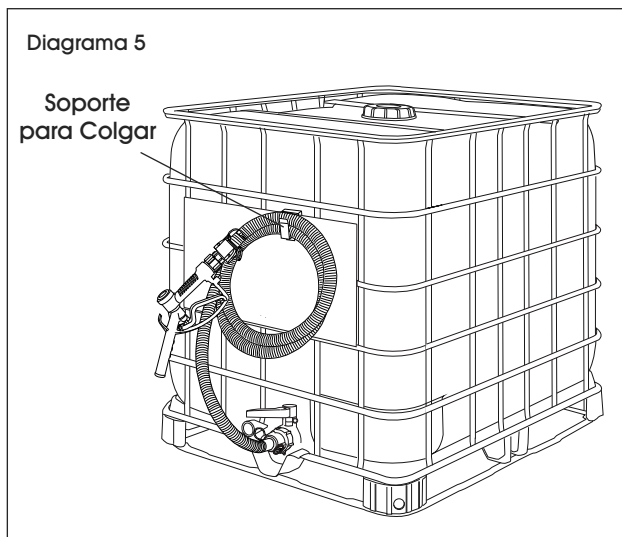

FUNCIONAMIENTO

1. Una vez que la manguera del IBC se haya ensamblado completamente, gire la válvula inferior a la posición de abierto. (Vea Diagrama 7)

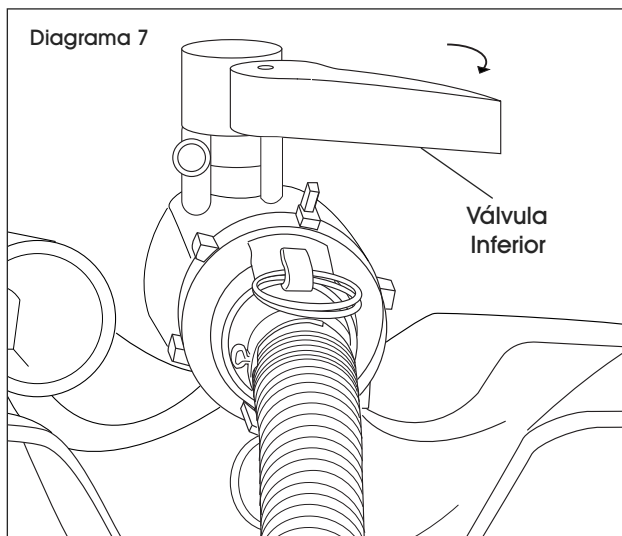

2. Jale del gatillo del mango para despachar el contenido del IBC. El gatillo de la boquilla puede bloquearse en la posición de despachar al presionar hacia abajo el botón de la boquilla. (Vea Diagrama 8)

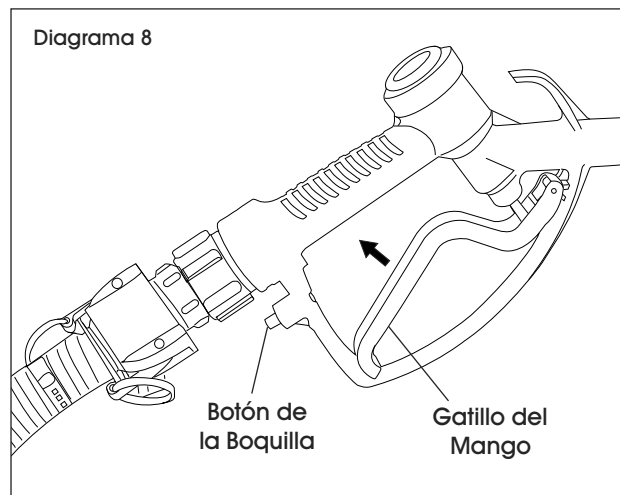

- NOTA: Se recomienda utilizar la manguera del IBC superior al estibar dos de alto.
- NOTA: Siempre almacene la manguera del IBC en el soporte para colgar cuando no la utilice.
- NOTA: Utilice solamente la manguera del IBC con líquidos compatibles con los materiales de la manguera del IBC.

ULINE

800-295-5510
uline.mx

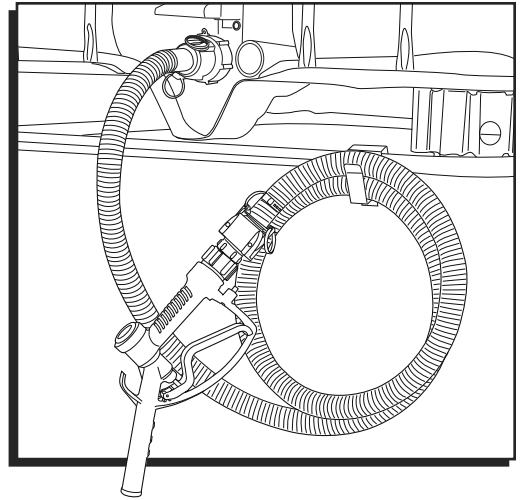

PIÈCES



Tuyau



Buse



Raccord GRV
femelle

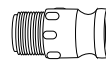

Raccord de buse
mâle



Support
d'accrochage



Ruban adhésif de
plomberie

ASSEMBLAGE

1. Dévissez l'ouverture de la bonde GRV de 2 po et vissez dessus le raccord GRV femelle. (Voir Figure 1)

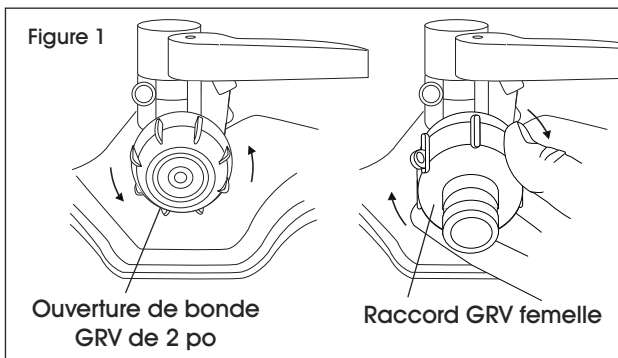

2. Reliez une des extrémités du tuyau au raccord GRV femelle. (Voir Figure 2)

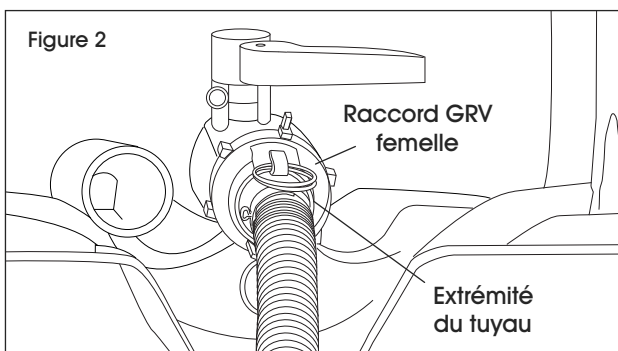

3. Appliquez du ruban adhésif de plomberie sur le filetage du raccord de buse mâle et vissez-le au bas de la buse. (Voir Figure 3)

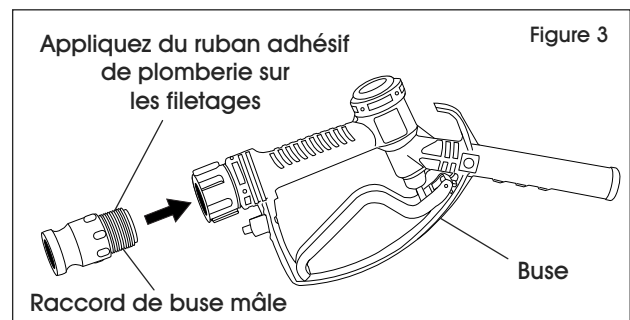

4. Reliez le raccord de buse mâle à l'extrémité opposée du tuyau. (Voir Figure 4)

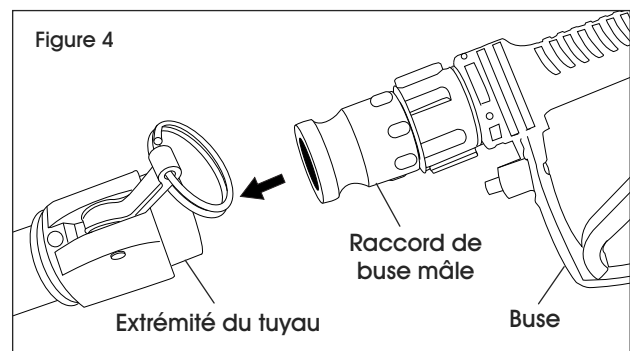

ASSEMBLAGE SUITE

5. Installez le support d'accrochage à la cage GRV. (Voir Figures 5 et 6)

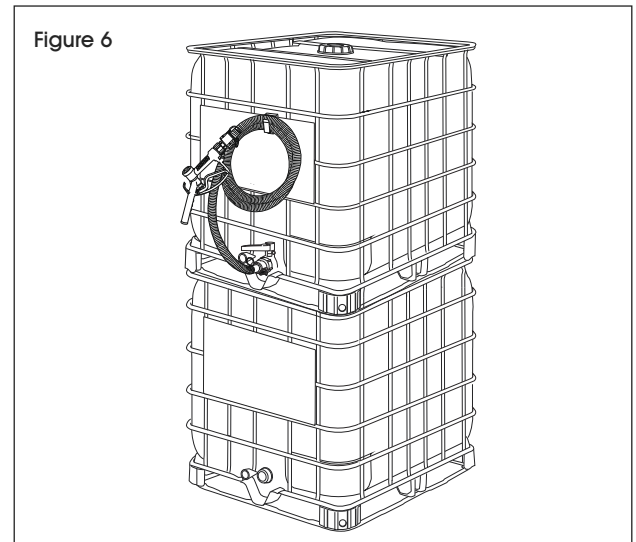
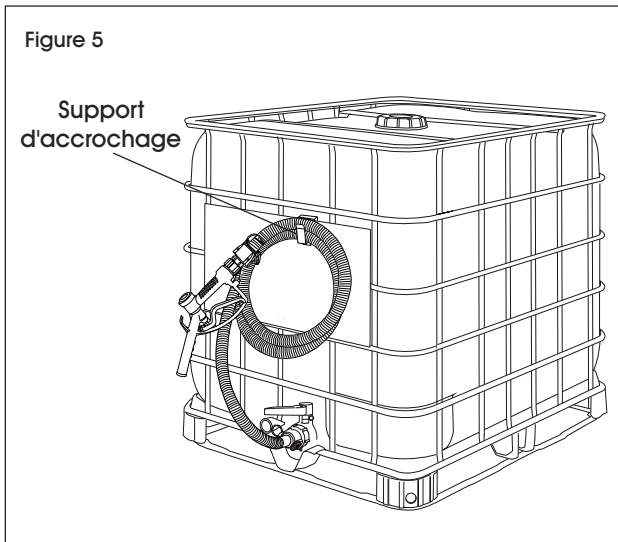



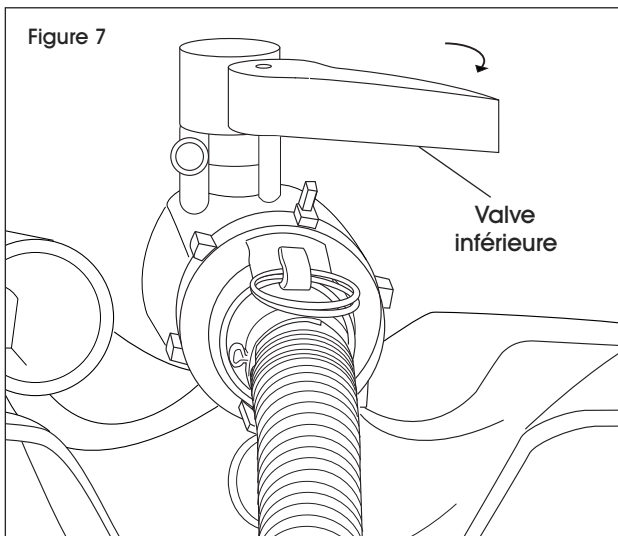

FONCTIONNEMENT

1. Une fois que le tuyau GRV est complètement assemblé, tournez la valve inférieure en position ouverte. (Voir Figure 7)

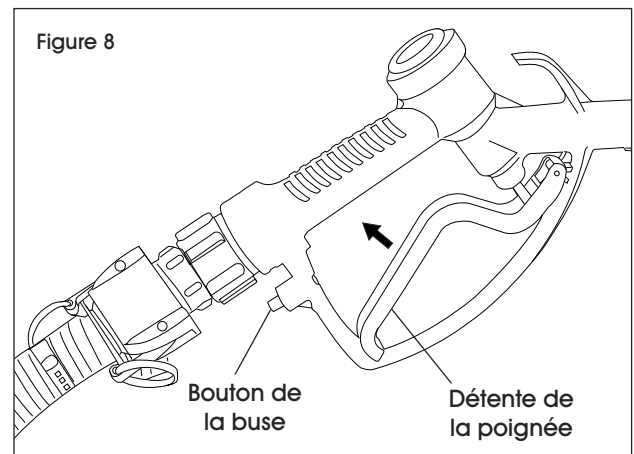

2. Tirez sur la détente de la poignée pour le transvasement du contenu du GRV. La détente de la buse peut être bloquée en position de transvasement en appuyant sur le bouton de la buse. (Voir Figure 8)



-  **REMARQUE :** L'utilisation d'un tuyau est recommandée sur le GRV se trouvant en hauteur lorsqu'ils sont empilés par deux.
-  **REMARQUE :** Placez toujours le tuyau sur le support d'accrochage lorsqu'il n'est pas utilisé.
-  **REMARQUE :** Utilisez uniquement le tuyau avec des liquides compatibles aux matériaux de tuyau GRV.

ULINE

1-800-295-5510
uline.ca