

# ULINE H-8204-R

## 66 x 72" STEEL L-DESK

WITH RIGHT-HAND RETURN

1-800-295-5510  
uline.com

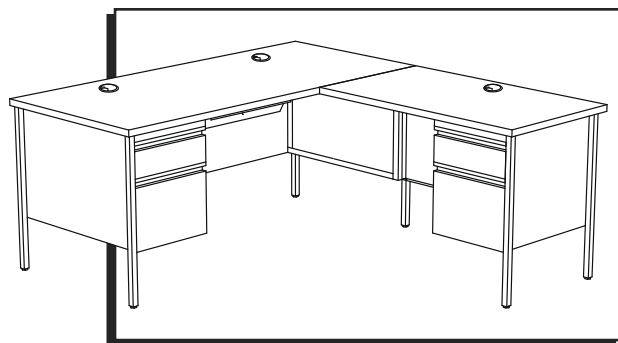

### TOOL NEEDED

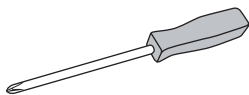

Phillips Screwdriver

 Two Person Assembly  
Recommended

## PARTS

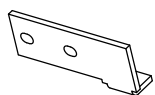

Leg Bracket x 6



Leg x 6

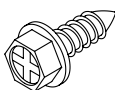

#8 x 1/2"  
Screw x 14

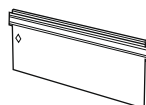

Drawer Divider x 2



Grommet x 3

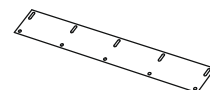

Top Connector  
Plate x 1



Bottom Connector  
Plate x 1

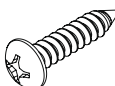

#8 x 3/4"  
Screw x 5



#8 x 1/4"  
Screw x 1



Key x 2

## ASSEMBLY



**NOTE:** Assemble on smooth, non-marring surface to avoid scratching.



**NOTE:** Check that all parts are included. Remove contents from drawer before assembling.



**WARNING!** Take care when handling metal parts. Sharp edges may cause injury.

1. With two people, turn pedestal desk upside down.
2. Place open end of leg over alignment peg on bottom of desktop at corner. (See Figure 1)

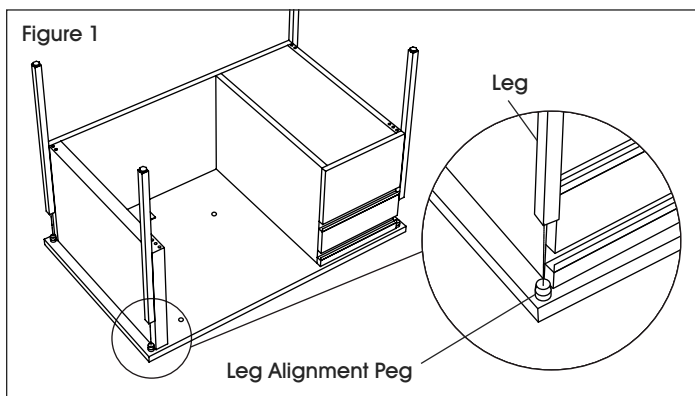

3. Insert one leg bracket into corresponding slot in leg. (See Figure 2)



**NOTE:** Bracket may flip up or down, depending on which leg user is installing.

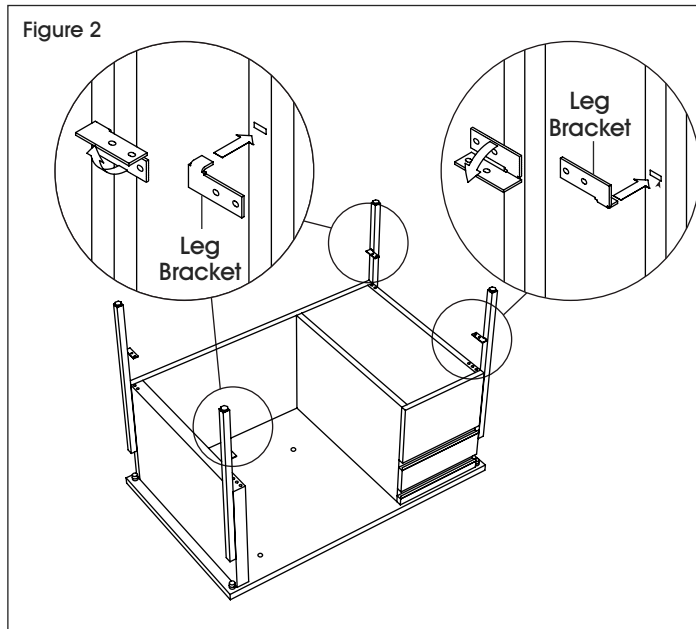

## ASSEMBLY CONTINUED

- Align leg bracket with holes in pedestal file. Use two #8 x 1/2" screws to secure. Repeat for remaining legs. (See Figure 3)

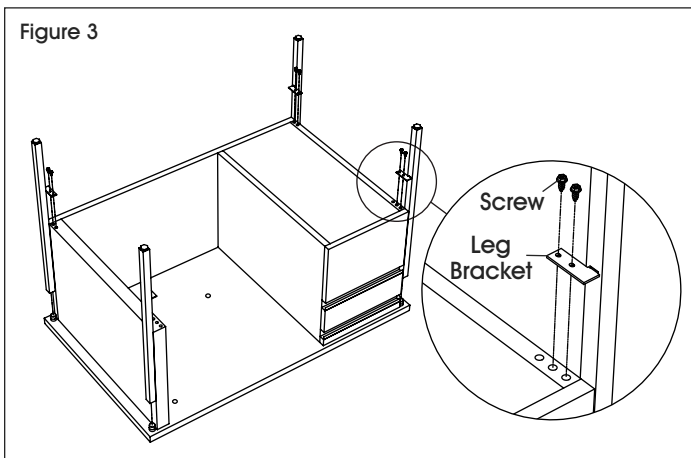

- With two people, set desk upright and position in desired location.
- With two people, turn return desk upside down.
- Remove two screws holding drawer to underside of return desktop. (See Figure 4)

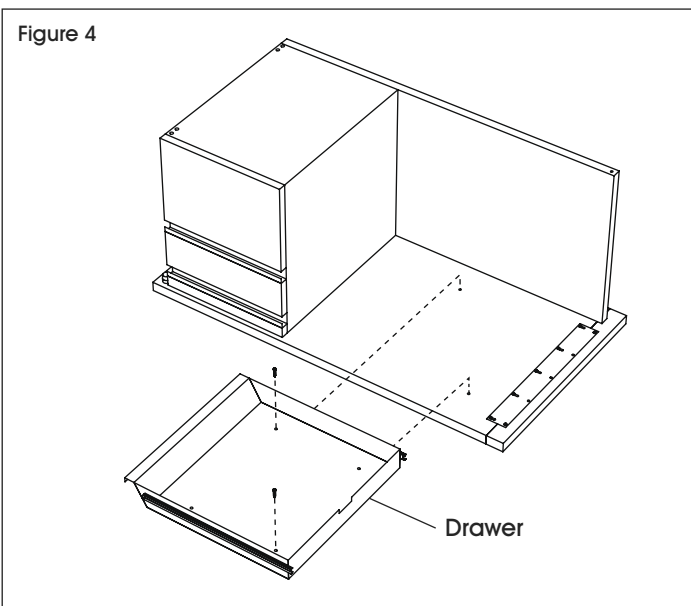

- Follow steps 2-4 to install remaining legs.

- Remove filler block and discard. (See Figure 5)

 **NOTE:** Keep filler block screws for next step.

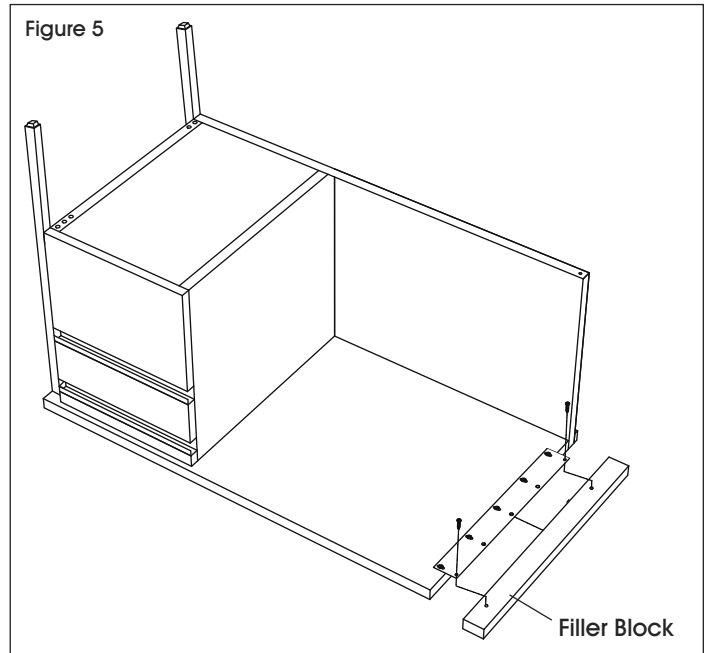

- With two people, set return desk upright and position with top connector plate under assembled 30 x 66" pedestal desk. Align holes and use five #8 x 3/4" screws to secure. (See Figure 6)

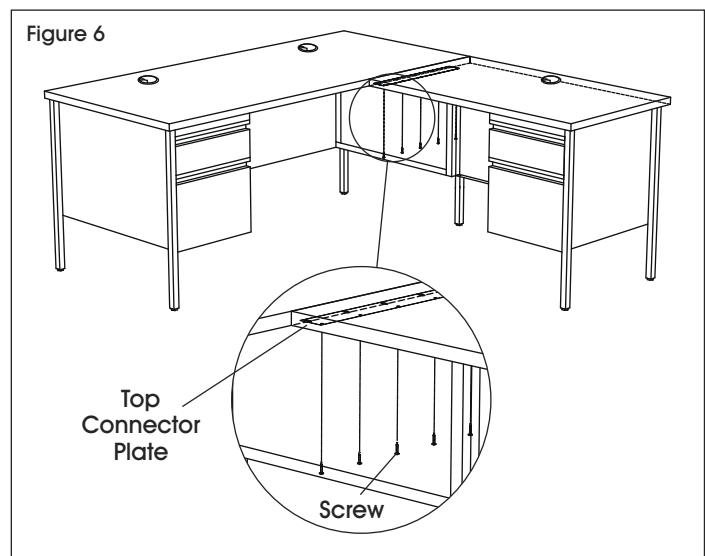

## ASSEMBLY CONTINUED

11. Align bottom connector plate with holes in pedestal desk and return desk. Use two #8 x 1/2" screws and one #8 x 1/4" screw to secure. (See Figure 7)



**NOTE:** Remove #8 x 1/4" screw from bottom connector plate before you install it. Once bottom connector plate is aligned, use same #8 x 1/4" screw to secure plate.

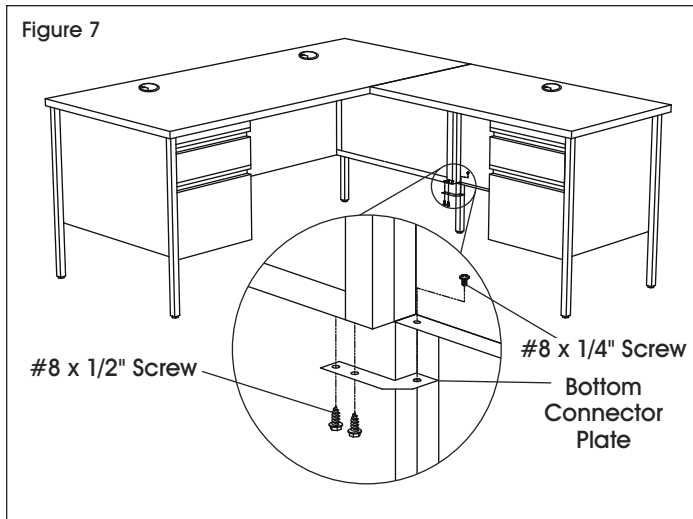

12. Extend drawer slides on underside of desk top. Pull ball bearing carrier forward and install center drawer into the extended slides. (See Figure 8)

Figure 8

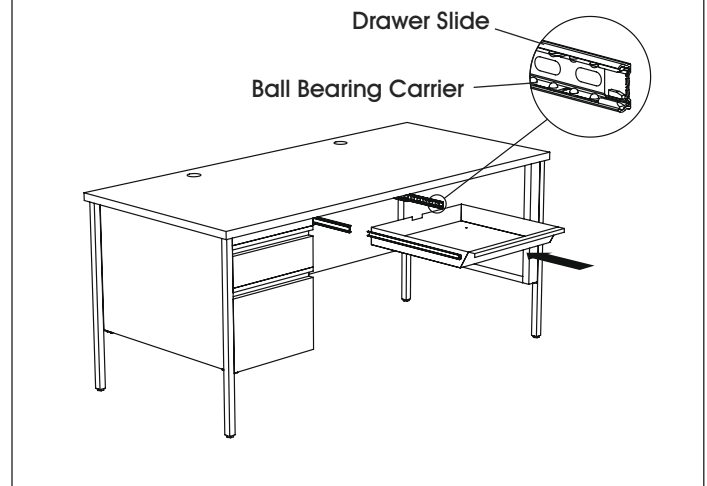

13. Adjust floor glides to compensate for uneven floors.
14. Place drawer dividers at desired locations in top drawers and insert grommets into desktop.

**ULINE**

1-800-295-5510  
uline.com

# ULINE H-8204-R

## ESCRITORIO EN L DE ACERO – 66 x 72"

CON RETORNO A LA DERECHA

800-295-5510  
uline.mx

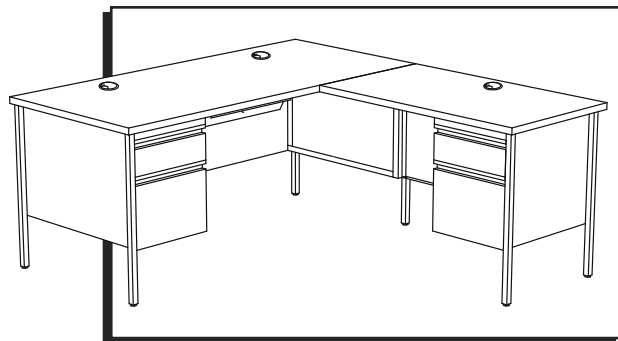

### HERRAMIENTA NECESARIA

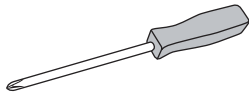

Desarmador de Cruz



Se recomienda Armar  
Entre Dos Personas

## PARTES

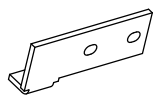

6 Soportes para Patas



6 Patas

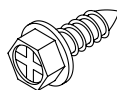

14 Tornillos #8 x 1/2"

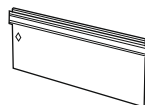

2 Divisores de Cajón



3 Ojales

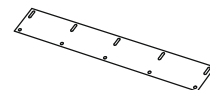

1 Placa de Conector Superior



1 Placa de Conector Inferior



5 Tornillos #8 x 3/4"



1 Tornillo #8 x 1/4"



2 Llaves

## ENSAMBLE



**NOTA:** Ensamble sobre una superficie lisa que no deje marcas para evitar rayones.



**NOTA:** Revise que todas las partes estén incluidas. Retire el contenido del cajón antes de ensamblar.



**¡ADVERTENCIA!** Debe tener cuidado cuando manipule piezas de metal. Los bordes filosos pueden causar lesiones.

1. Con la ayuda de dos personas, voltee el escritorio de pedestal boca abajo.
2. Coloque el extremo abierto de la pata sobre la clavija de alineamiento en la esquina de la parte inferior de la cubierta del escritorio. (Vea Diagrama 1)

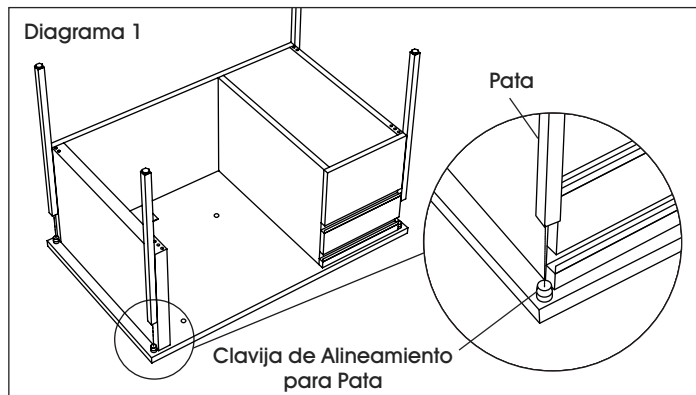

3. Inserte un soporte para pata en la ranura correspondiente de la pata. (Vea Diagrama 2)



**NOTA:** El soporte podría voltearse hacia arriba o abajo dependiendo de la pata que el usuario utilice.

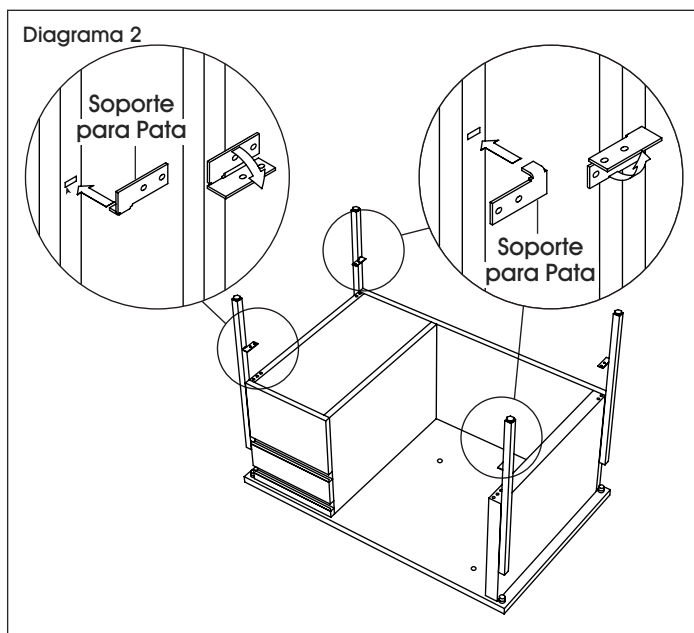

## CONTINUACIÓN DEL ENSAMBLE

4. Alinee el soporte para pata con los orificios del archivero de pedestal. Utilice dos tornillos #8 x 1/2" para asegurarlo. Repita la operación con las patas restantes. (Vea Diagrama 3)

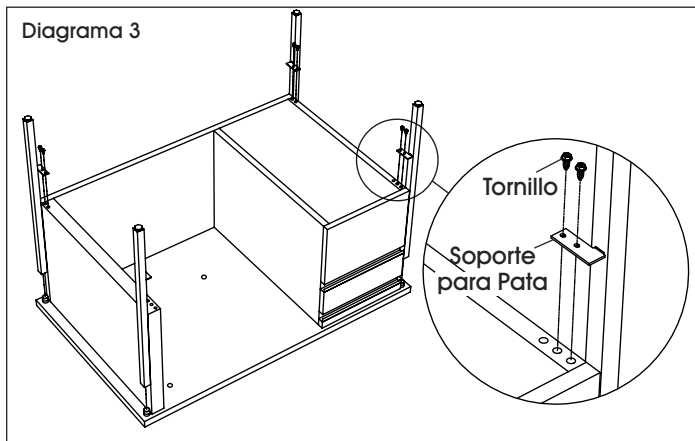

5. Con la ayuda de dos personas, enderece el escritorio y colóquelo en la ubicación deseada.
6. Con la ayuda de dos personas, voltee el escritorio de retorno boca abajo.
7. Retire los dos tornillos que fijan el cajón a la parte inferior de la cubierta de retorno. (Vea Diagrama 4)

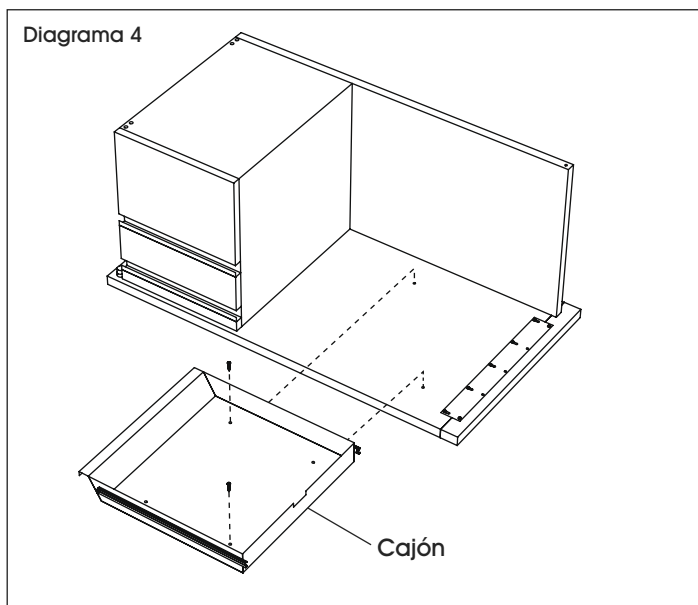

8. Siga los pasos 2-4 para instalar las patas restantes.

9. Quite el bloque de relleno y deséchelo. (Vea Diagrama 5)



**NOTA:** Guarde los tornillos del bloque de relleno para el próximo paso.

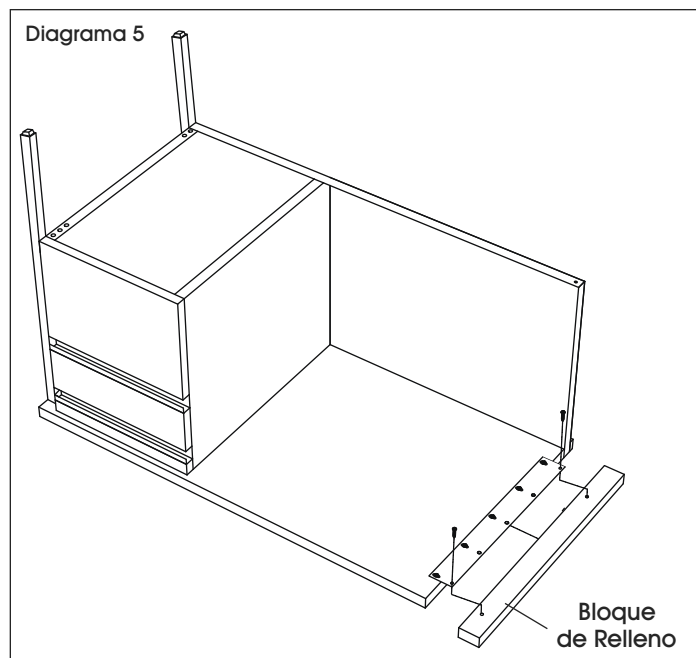

10. Con la ayuda de dos personas, enderece el escritorio de retorno y colóquelo con la placa del conector superior debajo del escritorio de pedestal de 30 x 66" ensamblado. Alinee los orificios y use cinco tornillos #8 x 3/4" para asegurarlo. (Vea Diagrama 6)

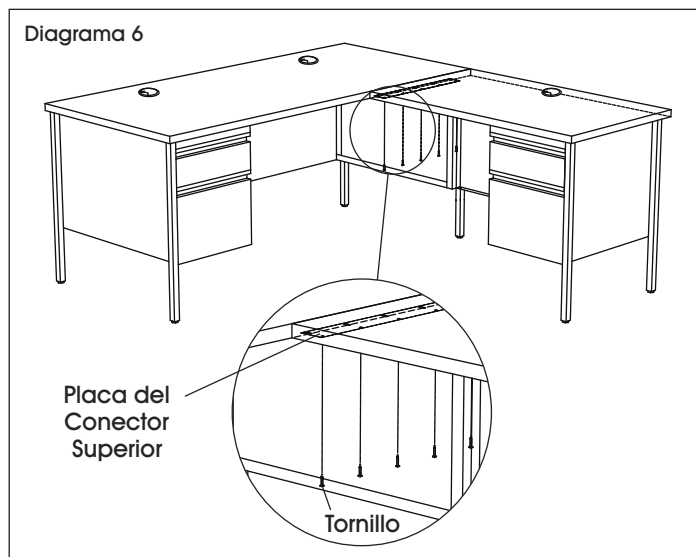

## CONTINUACIÓN DEL ENSAMBLE

11. Alinee la placa del conector inferior con los orificios del escritorio de pedestal y el escritorio de retorno. Use dos tornillos #8 x 1/2" y un tornillo #8 x 1/4" para asegurarla. (Vea Diagrama 7)

 **NOTA:** Retire el tornillo #8 x 1/4" de la placa del conector inferior antes de instalarla. Una vez que la placa del conector inferior quede alineada use el mismo tornillo #8 x 1/4" para asegurar la placa.

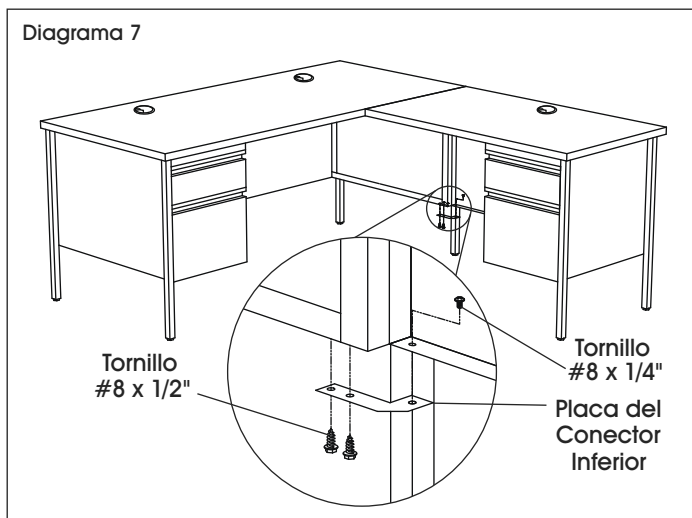

12. Extienda los rieles del cajón en la parte inferior de la cubierta del escritorio. Jale los portadores de rodamientos hacia enfrente e instale el cajón central en los rieles extendidos. (Vea Diagrama 8)

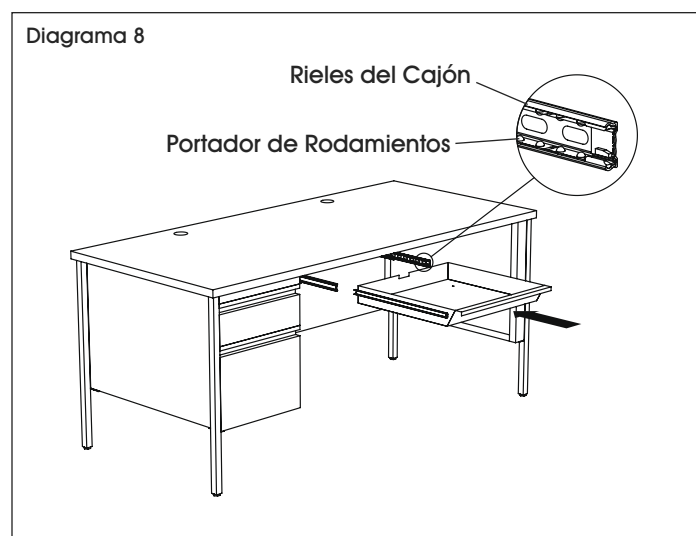

13. Ajuste los niveladores para compensar los pisos desnivelados.
14. Coloque los divisores en los cajones superiores e inserte los ojales en el escritorio.

**ULINE**

800-295-5510  
uline.mx

**ULINE** H-8204-R

**BUREAU EN L EN ACIER –  
66 x 72 po**

CONFIGURATION DE RETOUR À DROITE

**OUTIL REQUIS**

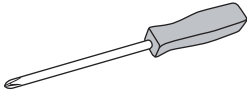

Tournevis cruciforme

1 800 295-5510

uline.ca

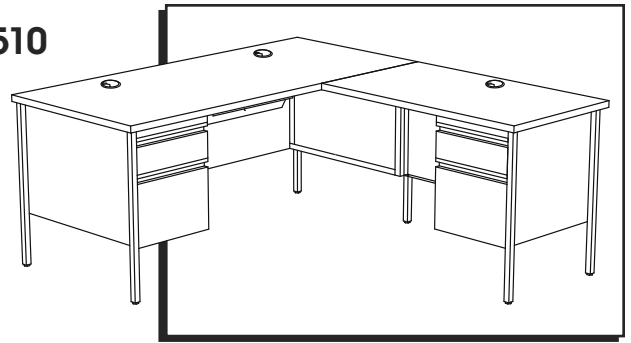

Montage à deux  
personnes recommandé

**PIÈCES**

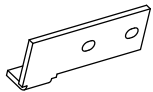

Support de  
pied x 6



Pied x 6

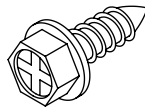

Vis n° 8 x 1/2 po  
x 14

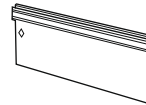

Séparateur de  
tiroir x 2

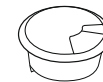

Passe-fil x 3

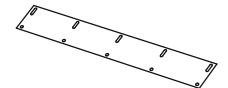

Plaque de connexion  
supérieure x 1

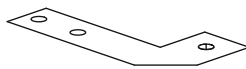

Plaque de connexion  
inférieure x 1

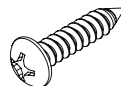

Vis n° 8 x 3/4 po  
x 5



Vis n° 8 x 1/4 po  
x 1



Clé x 2

**MONTAGE**



**REMARQUE :** Montez le bureau sur une surface lisse qui ne marque pas afin d'éviter les rayures.



**REMARQUE :** Vérifiez que toutes les pièces sont incluses. Retirez le contenu du tiroir avant le montage.



**AVERTISSEMENT!** Faites preuve de vigilance lors de la manipulation de pièces métalliques. Les bords tranchants peuvent causer des blessures.

1. À deux personnes, tournez le bureau à caisson à l'envers.
2. Placez l'extrémité ouverte d'un pied sur le taquet d'alignement dans l'un des coins sous le bureau. (Voir Figure 1)

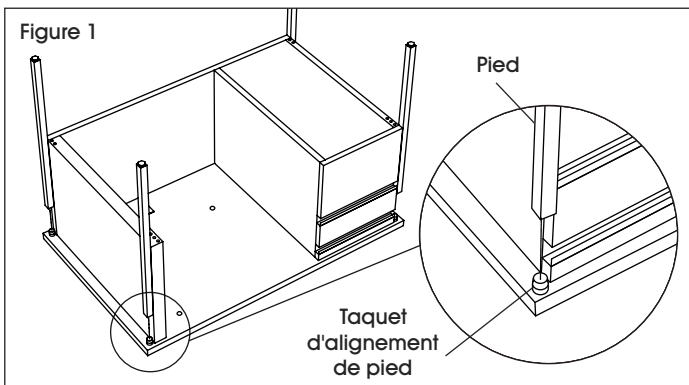

3. Insérez un support de pied dans la fente correspondante du pied. (Voir Figure 2)



**REMARQUE :** Le support peut basculer vers le haut ou vers le bas, selon le pied installé par l'utilisateur.

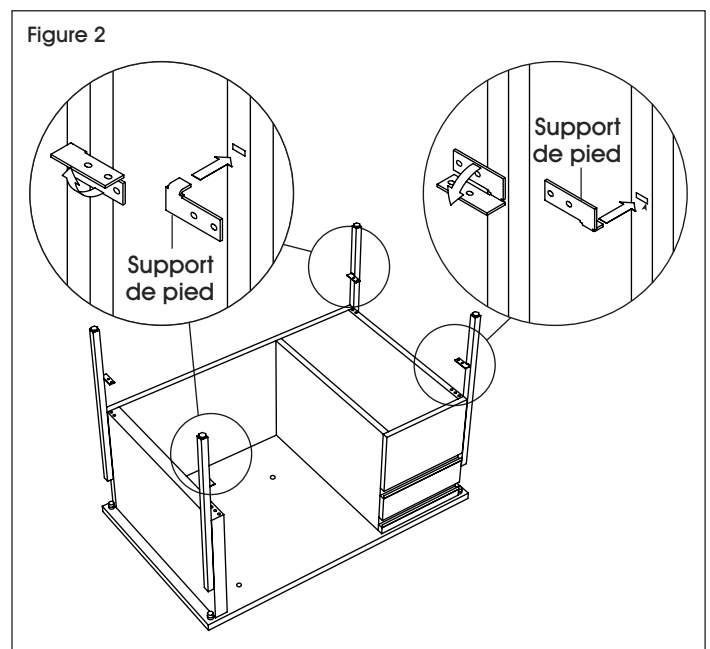

## MONTAGE SUITE

4. Alignez un support de pied sur les trous du classeur à caisson. Fixez avec deux vis n° 8 x 1/2 po. Répétez cette étape pour les autres pieds. (Voir Figure 3)

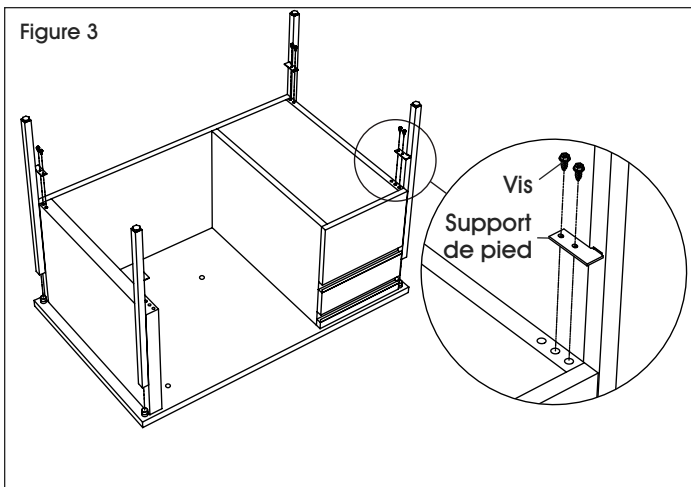

5. À deux, mettez le bureau à l'endroit et placez-le à l'emplacement souhaité.  
6. À deux, tournez le retour de bureau à l'envers.  
7. Retirez les deux vis qui relient le tiroir au dessous du retour de bureau. (Voir Figure 4)

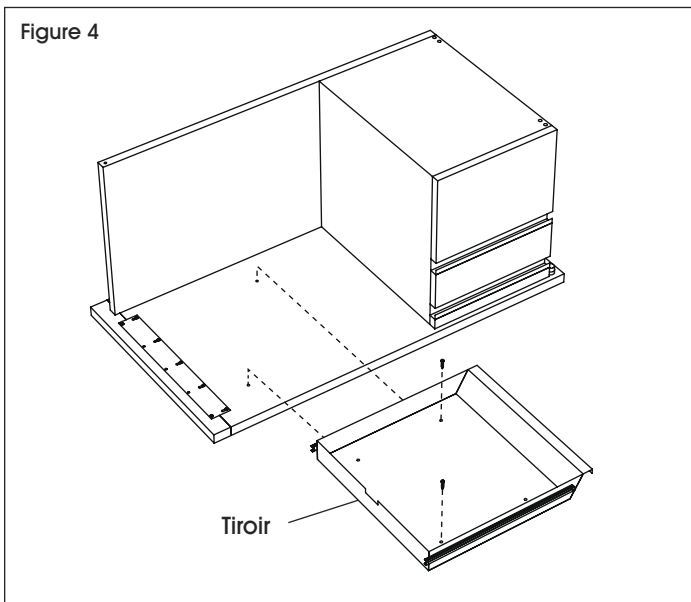

8. Suivez les étapes 2 à 4 pour installer les pieds restants.

9. Retirez l'entretoise d'assemblage et jetez-la. (Voir Figure 5)

 **REMARQUE :** Gardez les vis de l'entretoise d'assemblage pour la prochaine étape.

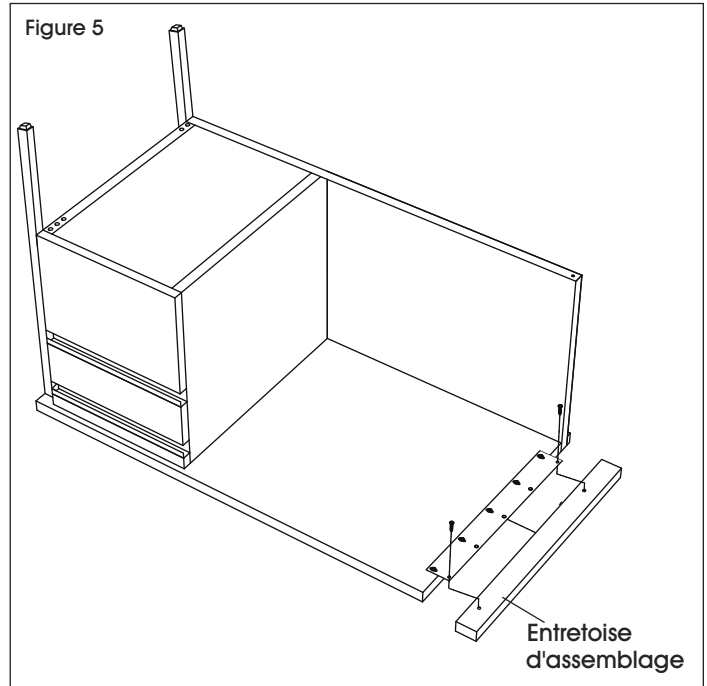

10. À deux, mettez le retour de bureau à l'endroit et positionnez la plaque de connexion supérieure sous l'ensemble du bureau à caisson de 30 x 66 po. Alignez les trous et fixez avec cinq vis n° 8 x 3/4 po. (Voir Figure 6)

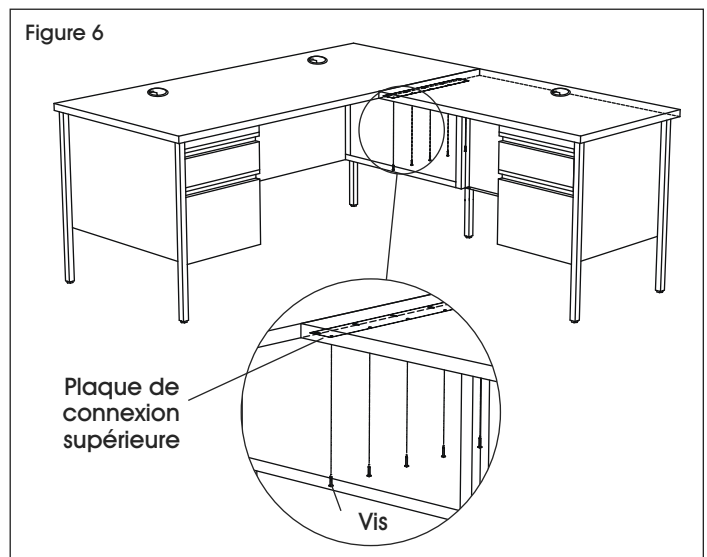

## MONTAGE SUITE

11. Alignez la plaque de connexion inférieure sur les trous du bureau à caisson et du retour. Fixez avec deux vis n° 8 x 1/2 po et une vis n° 8 x 1/4 po. (Voir Figure 7)

 **REMARQUE :** Retirez la vis n° 8 x 1/4 po de la plaque de connexion inférieure avant de l'installer. Utilisez cette même vis n° 8 x 1/4 po pour fixer la plaque de connexion dès que celle-ci est alignée.

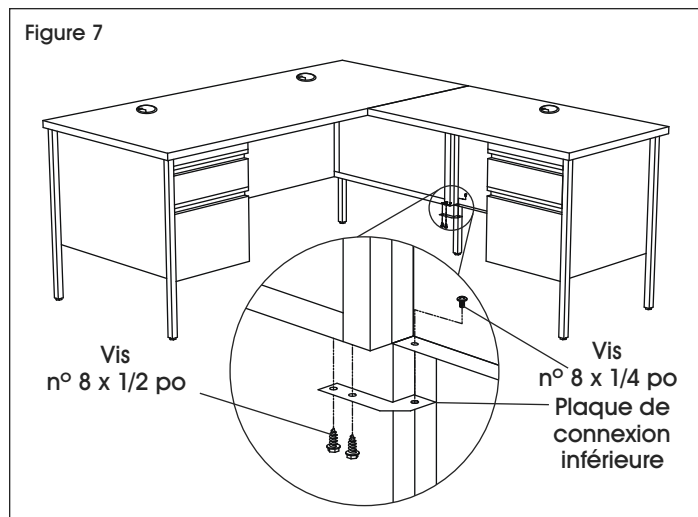

12. Déployez les glissières des tiroirs du dessous du bureau. Tirez le support de roulement à billes vers l'avant et installez le tiroir central dans les glissières déployées. (Voir Figure 8)

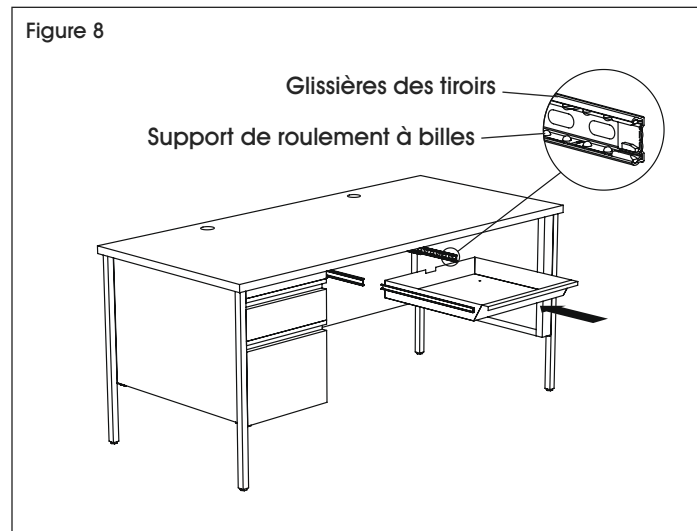

13. Ajustez les patins pour compenser les inégalités du sol.
14. Placez les séparateurs de tiroir aux endroits souhaités dans les tiroirs supérieurs et insérez les passe-fils dans le bureau.

**ULINE**

1 800 295-5510  
uline.ca