

ULINE H-8204

66 X 72" STEEL L-DESK

1-800-295-5510
uline.com

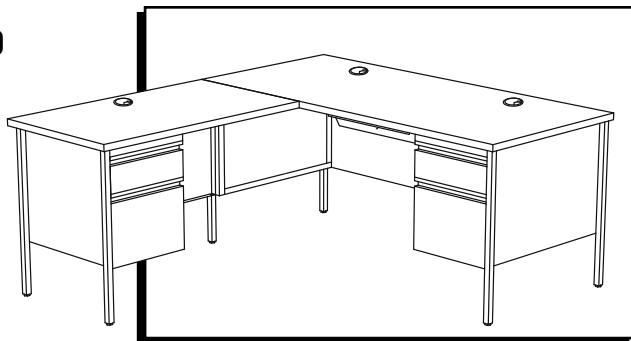

TOOL NEEDED

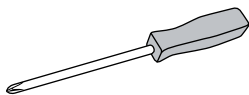

Phillips Screwdriver



Two Person Assembly
Recommended

PARTS

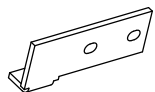

Leg Bracket x 6



Leg x 6

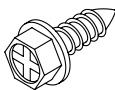

Screw x 14
#8 x 1/2"

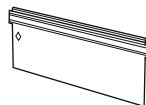

Drawer Divider x 2



Grommet x 3

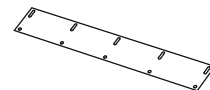

Top Connector
Plate x 1

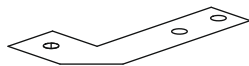

Bottom Connector
Plate x 1



Screw x 5
#8 x 3/4"



Screw x 1
#8 x 1/4"



Key x 2

ASSEMBLY



NOTE: Assemble on smooth, non-marring surface to avoid scratching.



NOTE: Check that all parts are included. Remove contents from drawer before assembling.



WARNING! Take care when handling metal parts. Sharp edges may cause injury.

1. With two people, turn pedestal desk upside down.
2. Place open end of leg over alignment peg on bottom of desktop at corner. (See Figure 1)

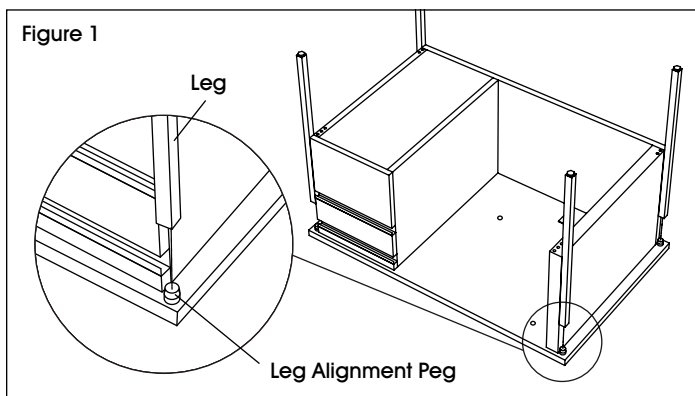

3. Insert one leg bracket into corresponding slot in leg. (See Figure 2)



NOTE: Bracket may flip up or down, depending on which leg user is installing.

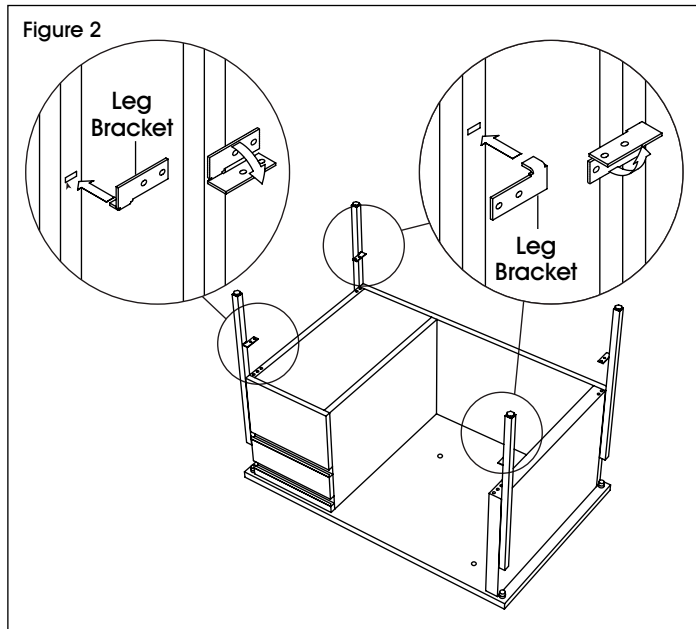

ASSEMBLY CONTINUED

- Align leg bracket with holes in pedestal file. Use two #8 x 1/2" screws to secure. Repeat for remaining legs. (See Figure 3)

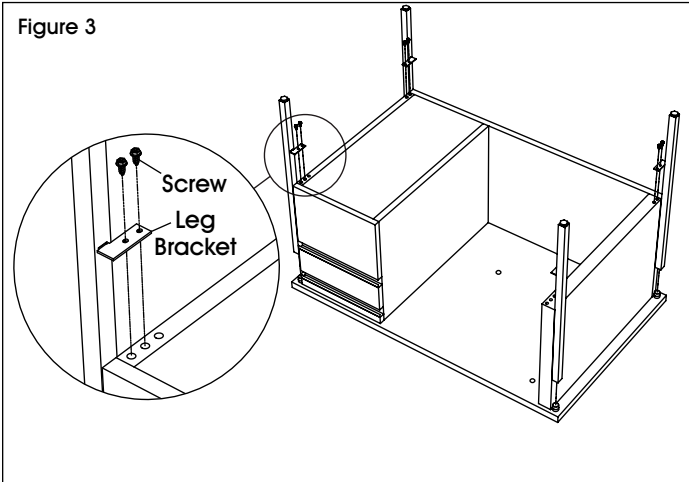

- With two people, set desk upright and position in desired location.
- With two people, turn return desk upside down.
- Remove two screws holding drawer to underside of return desktop. (See Figure 4)

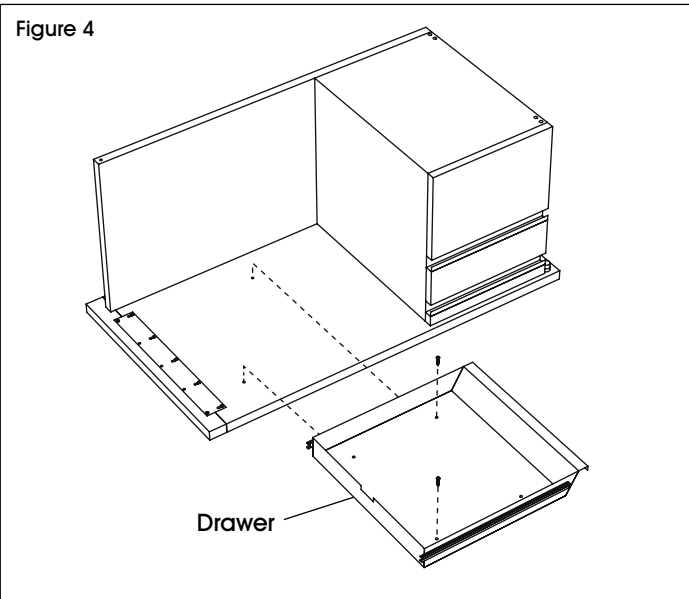

- Follow steps 2-4 to install remaining legs.

- Remove filler block and discard. (See Figure 5)

 **NOTE:** Keep filler block screws for next step.

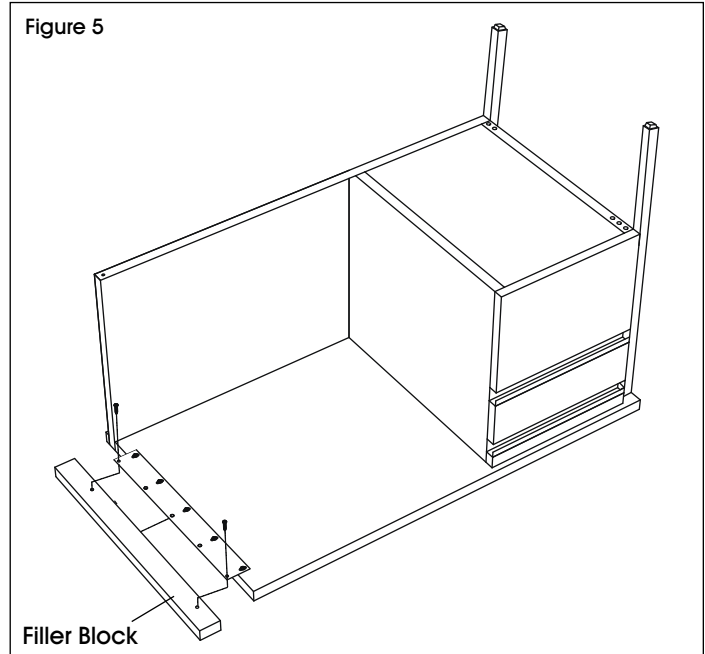

- With two people, set return desk upright and position with top connector plate under assembled 30 x 66" pedestal desk. Align holes and use five #8 x 3/4" screws to secure. (See Figure 6)

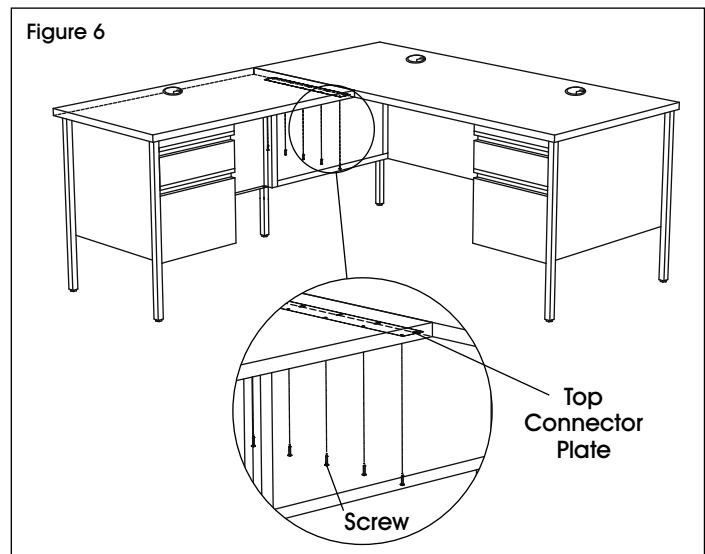

ASSEMBLY CONTINUED

11. Align bottom connector plate with holes in pedestal desk and return desk. Use two #8 x 1/2" screws and one #8 x 1/4" screw to secure. (See Figure 7)



NOTE: Remove #8 x 1/4" screw from bottom connector plate before you install it. Once bottom connector plate is aligned, use same #8 x 1/4" screw to secure plate.

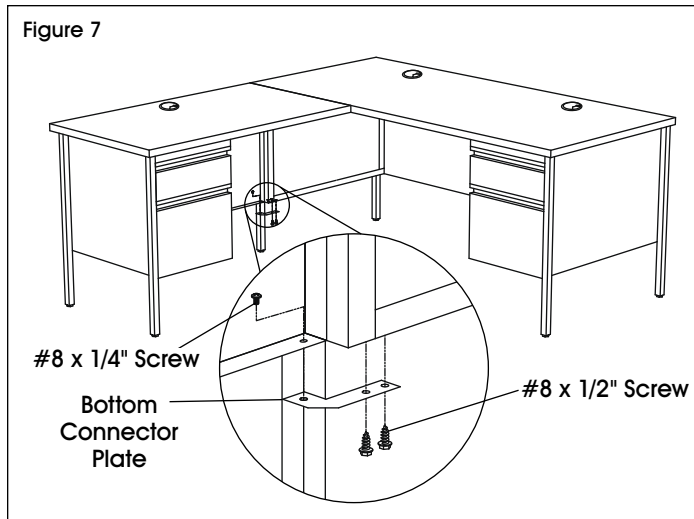

12. Extend drawer slides on underside of desk top. Pull ball bearing carrier forward and install center drawer into the extended slides. (See Figure 8)

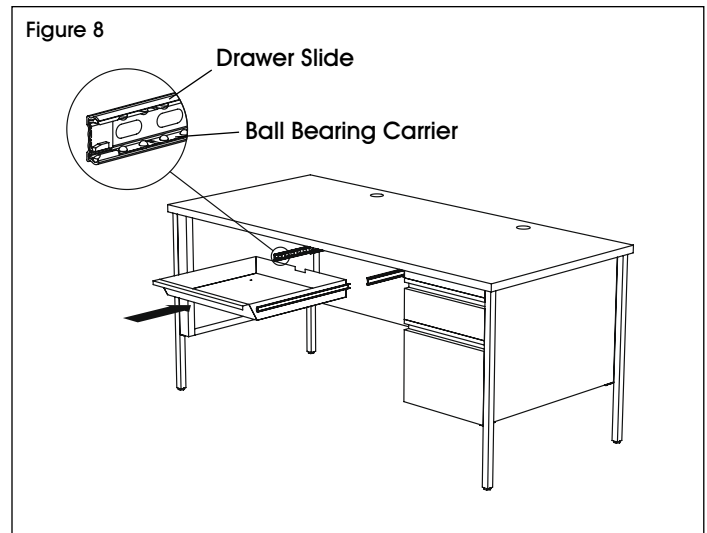

13. Adjust floor glides to compensate for uneven floors.
14. Place drawer dividers at desired locations in top drawers and insert grommets into desktop.

ULINE

1-800-295-5510
uline.com

ULINE H-8204

ESCRITORIO DE ACERO EN L DE 66 X 72"

800-295-5510

uline.mx

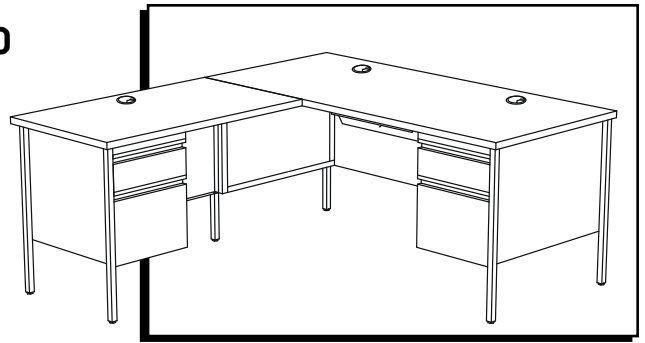

HERRAMIENTA NECESARIA

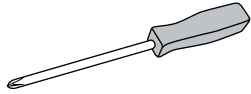

Desarmador de Cruz



Se recomienda Armar
Entre Dos Personas

PARTES

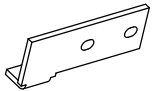

6 Soportes
para Patas



6 Patas

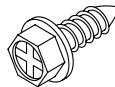

14 Tornillos
#8 x 1/2"

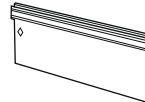

2 Divisores de
Cajón



3 Ojales

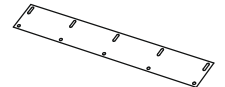

1 Placa de
Conector Superior

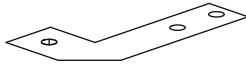

1 Placa de
Conector Inferior

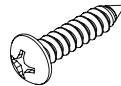

5 Tornillos
#8 x 3/4"



1 Tornillo
#8 x 1/4"



2 Llaves

ENSAMBLE



NOTA: Ensamble sobre una superficie lisa que no deje marcas para evitar rayones.



NOTA: Vérifiez que toutes les pièces sont incluses. Retirez le contenu du tiroir avant le montage.



¡ADVERTENCIA! Debe tener cuidado cuando manipule piezas de metal. Los bordes filosos pueden causar lesiones.

1. Con la ayuda de dos personas, voltee el escritorio de pedestal boca abajo.
2. Coloque el extremo abierto de la pata sobre la clavija de alineamiento en la esquina de la parte inferior de la cubierta del escritorio. (Vea Diagrama 1)

Diagrama 1

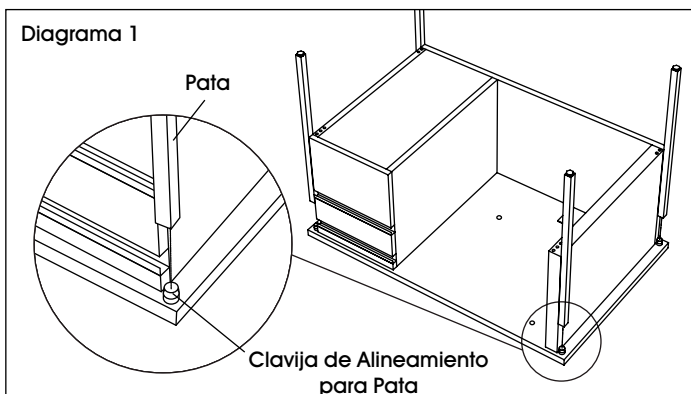

3. Inserte un soporte para pata en la ranura correspondiente de la pata. (Vea Diagrama 2)



NOTA: El soporte podría voltearse hacia arriba o abajo dependiendo de la pata que el usuario utilice.

Diagrama 2

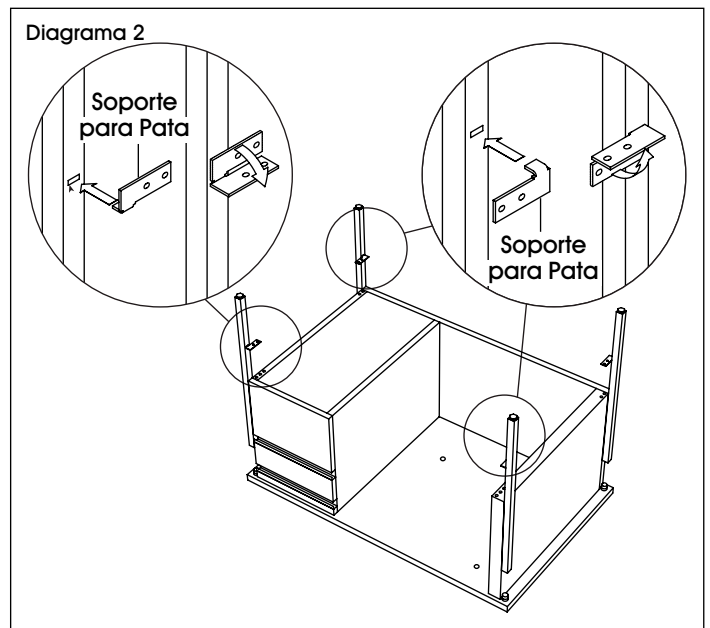

CONTINUACIÓN DEL ENSAMBLE

4. Alinee el soporte para pata con los orificios del archivero de pedestal. Utilice dos tornillos #8 x 1/2" para asegurarlo. Repita la operación con las patas restantes. (Vea Diagrama 3)

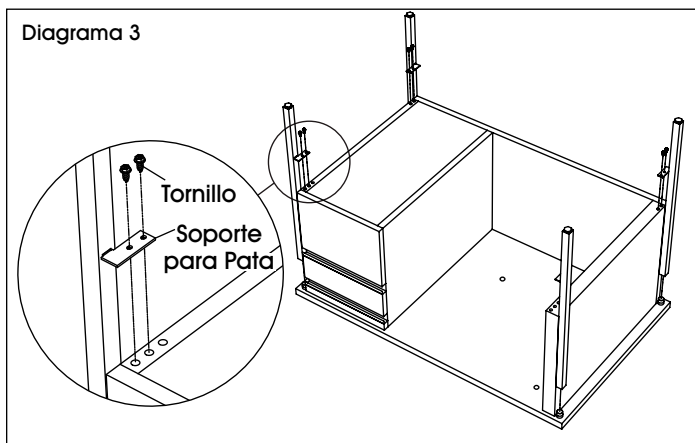

5. Con la ayuda de dos personas, enderece el escritorio y colóquelo en la ubicación deseada.
6. Con la ayuda de dos personas, voltee el escritorio de retorno boca abajo.
7. Retire los dos tornillos que fijan el cajón a la parte inferior de la cubierta de retorno. (Vea Diagrama 4)

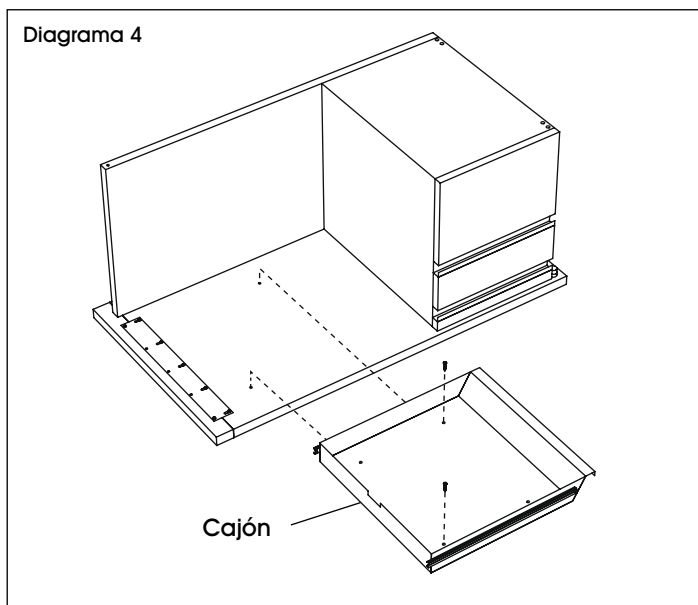

8. Siga los pasos 2-4 para instalar las patas restantes.

9. Quite el bloque de relleno y deséchelo. (Vea Diagrama 5)

 **NOTA:** Guarde los tornillos del bloque de relleno para el próximo paso.

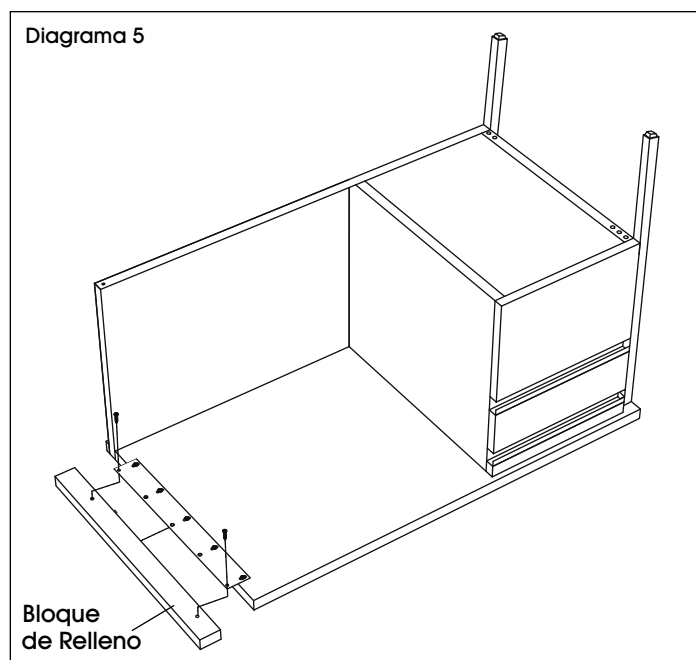

10. Con la ayuda de dos personas, enderece el escritorio de retorno y colóquelo con la placa del conector superior debajo del escritorio de pedestal de 30 x 66" ensamblado. Alinee los orificios y use cinco tornillos #8 x 3/4" para asegurarlo. (Vea Diagrama 6)

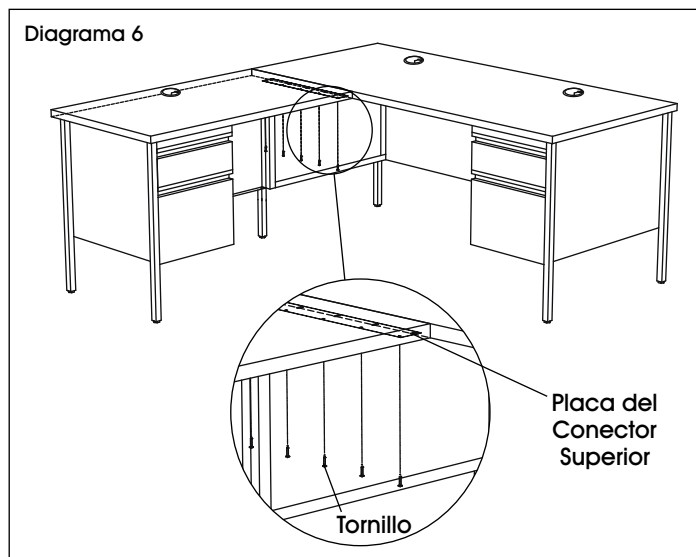

CONTINUACIÓN DEL ENSAMBLE

11. Alinee la placa del conector inferior con los orificios del escritorio de pedestal y el escritorio de retorno. Use dos tornillos #8 x 1/2" y un tornillo #8 x 1/4" para asegurarla. (Vea Diagrama 7)

 **NOTA:** Retire el tornillo #8 x 1/4" de la placa del conector inferior antes de instalarla. Una vez que la placa del conector inferior quede alineada use el mismo tornillo #8 x 1/4" para asegurar la placa.

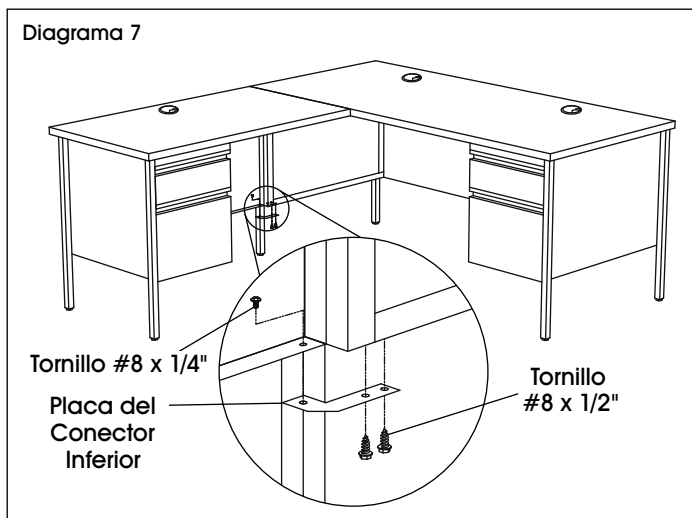

12. Extienda los rieles del cajón en la parte inferior de la cubierta del escritorio. Jale los portadores de rodamientos hacia enfrente e instale el cajón central en los rieles extendidos. (Vea Diagrama 8)

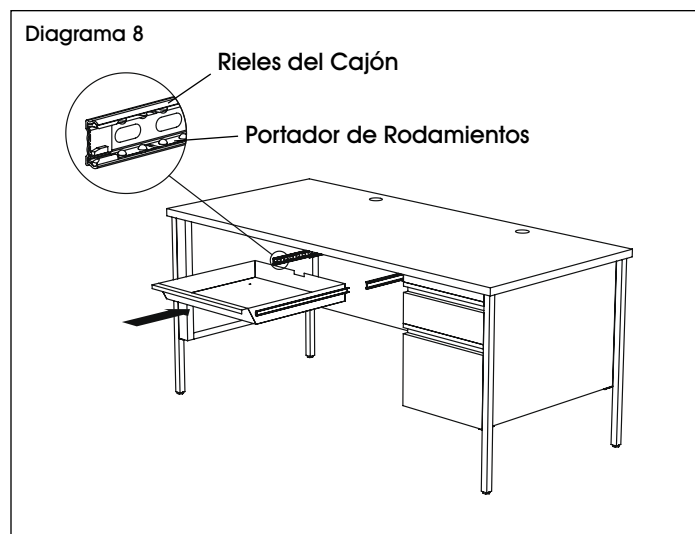

13. Ajuste los niveladores para compensar los pisos desnivelados.
14. Coloque los divisores en los cajones superiores e inserte los ojales en el escritorio.

ULINE

800-295-5510
uline.mx

ULINE H-8204

**BUREAU EN L EN ACIER –
66 X 72 PO**

1-800-295-5510

uline.ca

OUTIL REQUIS

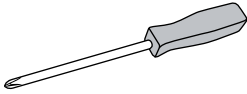

Tournevis cruciforme



Montage à deux
personnes recommandé

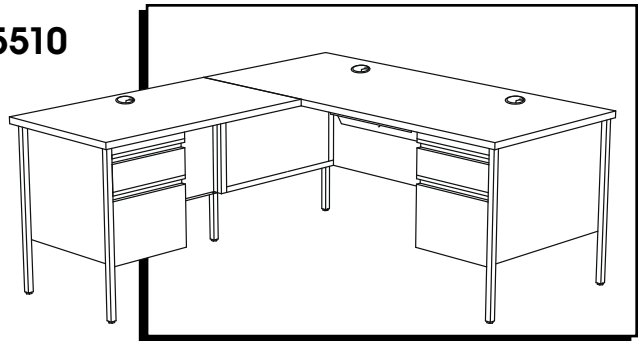

PIÈCES

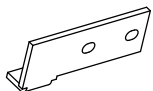

Support de pied x 6



Pied x 6

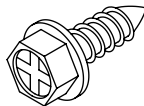

Vis x 14
N° 8 x 1/2 po

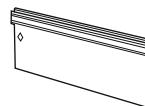

Séparateur de
tiroir x 2



Passe-fil x 3

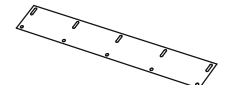

Plaque de connexion
supérieure x 1

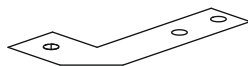

Plaque de connexion
inférieure x 1

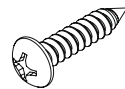

Vis x 5
N° 8 x 3/4 po



Vis x 1
N° 8 x 1/4 po



Clé x 2

MONTAGE



REMARQUE : Montez le bureau sur une surface lisse qui ne marque pas afin d'éviter les rayures.



REMARQUE : Vérifiez que toutes les pièces sont incluses. Retire el contenido del cajón antes de ensamblar.



AVERTISSEMENT! Faites preuve de vigilance lors de la manipulation de pièces métalliques. Les bords tranchants peuvent causer des blessures.

1. À deux personnes, tournez le bureau à caisson à l'envers.
2. Placez l'extrémité ouverte d'un pied sur le taquet d'alignement dans l'un des coins sous le bureau. (Voir Figure 1)

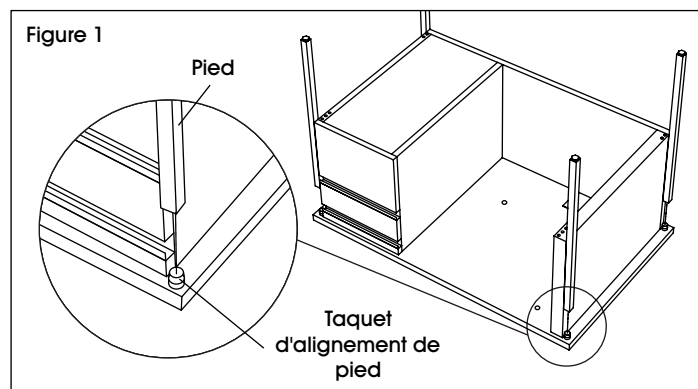

3. Insérez un support de pied dans la fente correspondante du pied. (Voir Figure 2)



REMARQUE : Le support peut basculer vers le haut ou vers le bas, selon le pied installé par l'utilisateur.

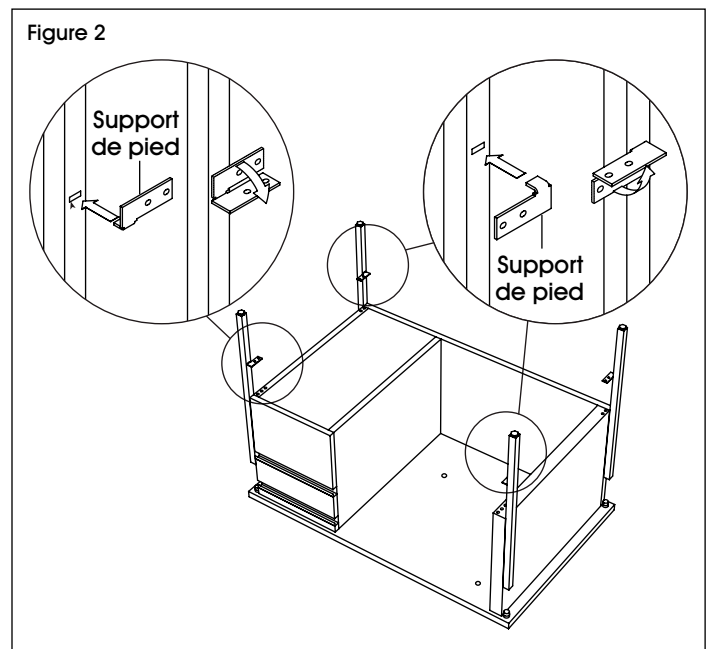

MONTAGE SUITE

4. Alignez un support de pied sur les trous du classeur à caisson. Fixez avec deux vis n° 8 x 1/2 po. Répétez cette étape pour les autres pieds. (Voir Figure 3)

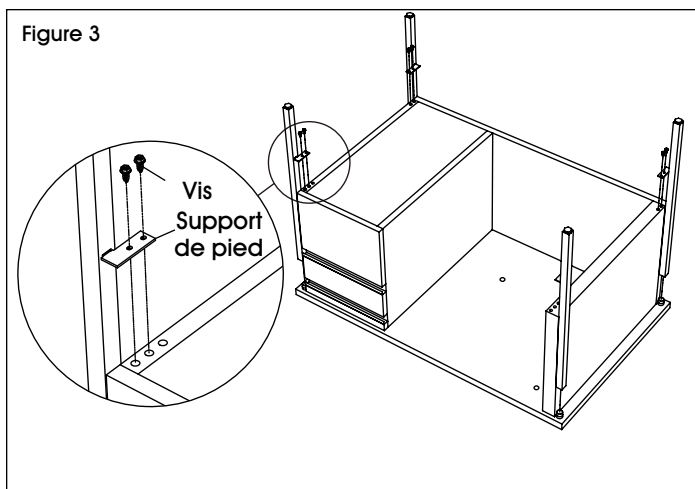

5. À deux, mettez le bureau à l'endroit et placez-le à l'emplacement souhaité.
6. À deux, tournez le bureau de retour à l'envers.
7. Retirer les deux vis qui relient le tiroir au dessous du bureau de retour. (Voir Figure 4)

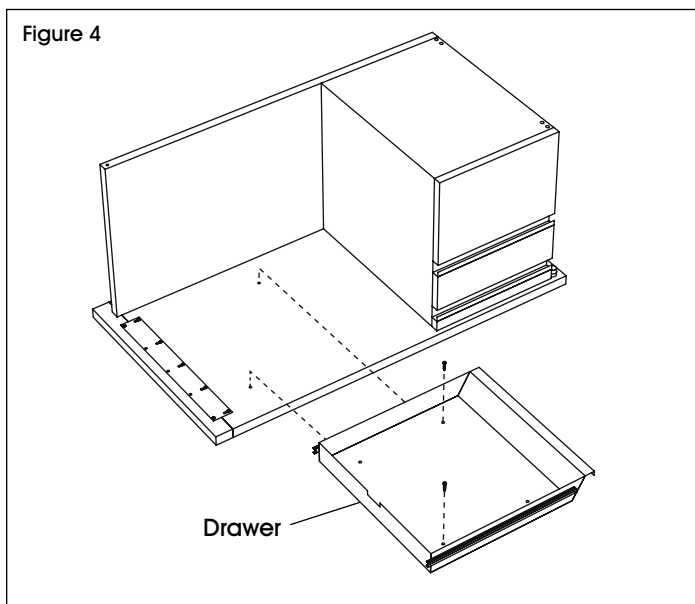

8. Suivez les étapes 2 à 4 pour installer les pieds restants.

9. Retirez l'entretoise d'assemblage et jetez-la. (Voir Figure 5)

 **REMARQUE :** Gardez les vis de l'entretoise d'assemblage pour la prochaine étape.

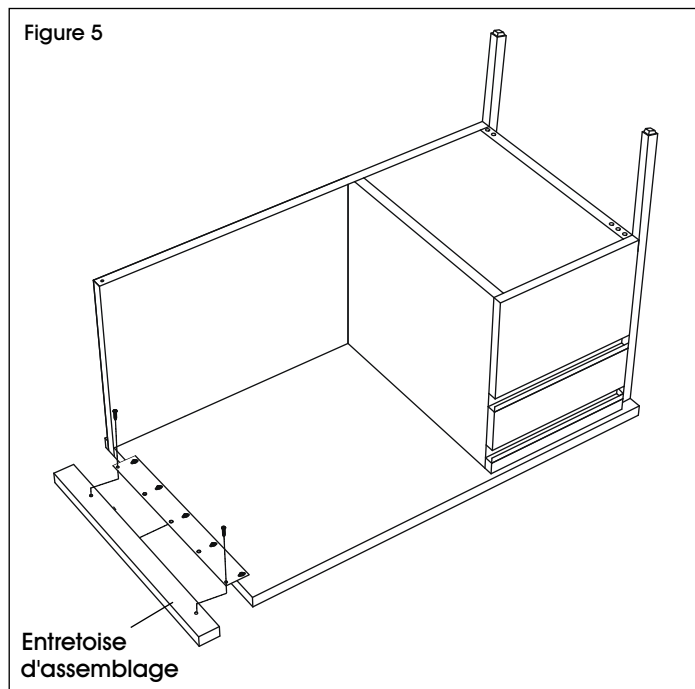

10. À deux, mettez le bureau de retour à l'endroit et positionnez la plaque de connexion supérieure sous l'ensemble du bureau à caisson de 30 x 66 po. Alignez les trous et fixez avec cinq vis n° 8 x 3/4 po. (Voir Figure 6)

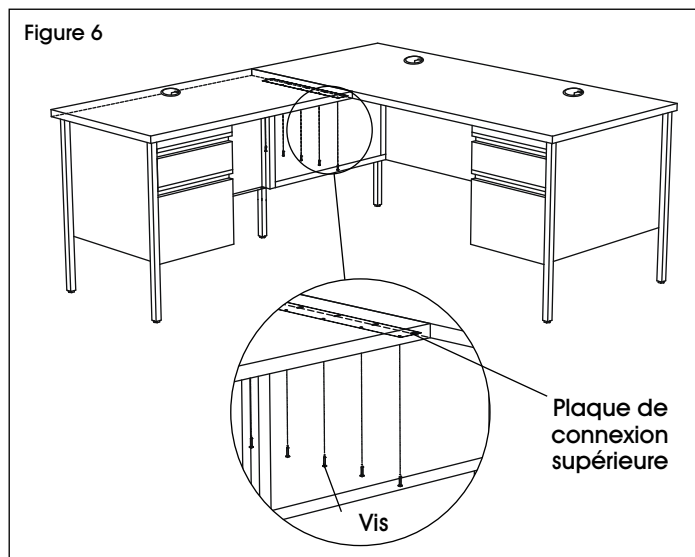

MONTAGE SUITE

11. Alignez la plaque de connexion inférieure sur les trous des bureaux à caisson et de retour. Fixez avec deux vis n° 8 x 1/2 po et une vis n° 8 x 1/4 po. (Voir Figure 7)



REMARQUE : Retirez la vis n° 8 x 1/4 po de la plaque de connexion inférieure avant de l'installer. Utilisez cette même vis n° 8 x 1/4 po pour fixer la plaque de connexion inférieure dès que celle-ci est alignée.

Figure 7

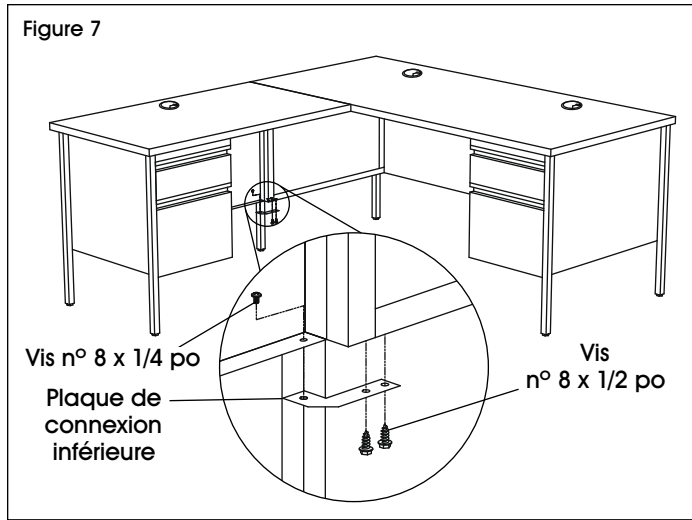

12. Déployer les glissières des tiroirs du dessous du bureau. Tirez le support de roulement à billes vers l'avant et installez le tiroir central dans les glissières déployées. (Voir Figure 8)

Figure 8

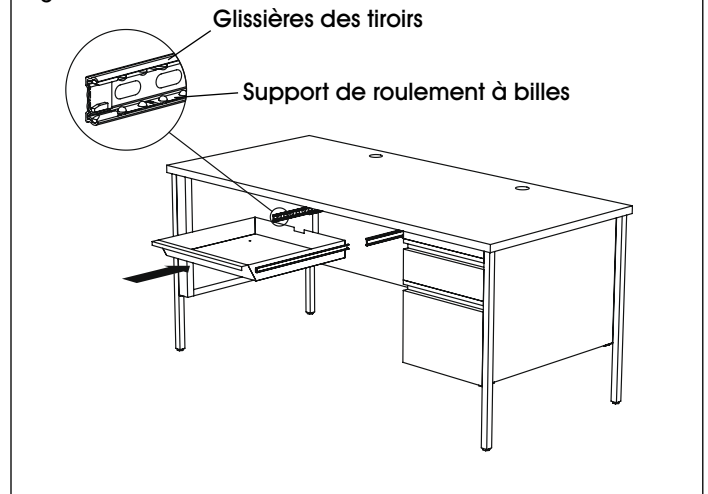

13. Ajustez les patins pour compenser les inégalités du sol.
14. Placez les séparateurs de tiroir aux endroits souhaités dans les tiroirs supérieurs et insérez les passe-fils dans le bureau.

ULINE

1-800-295-5510
uline.ca