

ULINE H-8263

96 x 48" MEDIA CONFERENCE TABLE

1-800-295-5510
uline.com

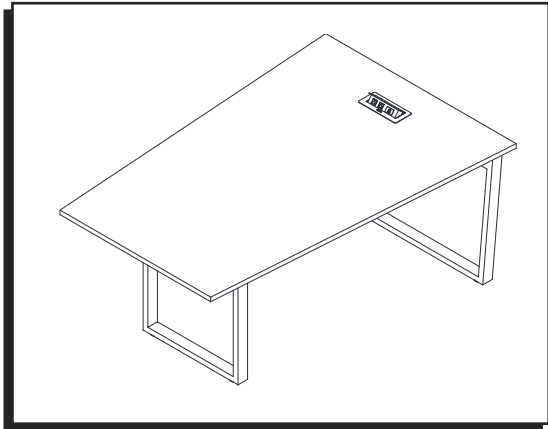

TOOLS NEEDED



Allen Wrench
(Included)

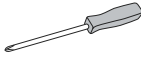

Phillips
Screwdriver



Three Person Assembly
Recommended

PARTS

- | | | | | | | |
|------------------------|-------------------------|-------------------------|-------------------------|------------------|---------------------------|-----------------------------------|
| A | B | C | D | E | F | G |
| | | | | | | |
| Bolt x 5 M6 x 45 mm | Bolt x 12 M6 x 15 mm | Bolt x 20 M6 x 60 mm | Bolt x 32 M6 x 12 mm | Flat Bracket x 1 | Screw x 4 M3.5 x 10 mm | Adhesive-Backed Cable Clip x 4 |

ASSEMBLY

NOTE: Check that all parts are included. The four M3.5 x 10 mm screws (F) come packaged with the power center.

NOTE: Table also includes flat bracket and six extra M6 x 15 mm bolts for the option to connect two tables.

1. Fit support rail (1) over corresponding bracket on narrow leg (2). Secure using four M6 x 12 mm bolts (D). Repeat to attach three remaining support rails. (See Figure 1)
2. Attach all support rails (1) to wide leg (3) using four M6 x 12 mm bolts (D) per rail. (See Figure 1)

NOTE: Do not fully tighten bolts until tabletop is attached.

3. Place tabletop (4) on assembled frame. Attach tabletop (4) to narrow leg (2) using two M6 x 45 mm bolts (A). Secure wide leg (3) using three M6 x 45 mm bolts (A). (See Figure 2)
4. Attach tabletop (4) to brackets on legs using two M6 x 15 mm bolts (B) per bracket. (See Figure 2)
5. Secure tabletop (4) to support rails (1) using five M6 x 60 mm bolts (C) per rail. (See Figure 2)

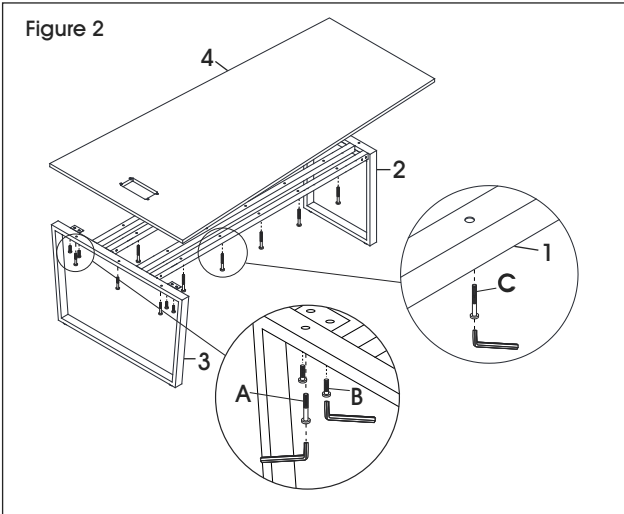
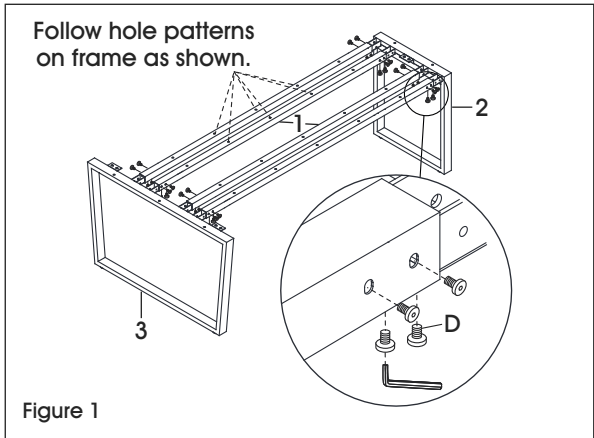

6. Tighten bolts (D) installed in Steps 1 and 2 with Allen wrench.

ASSEMBLY CONTINUED

7. Remove pop up outlets from power center casing by turning screws counterclockwise. (See Figure 3)

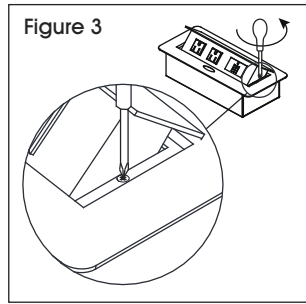

8. Insert power center casing in corresponding hole in tabletop (4). (See Figure 4)

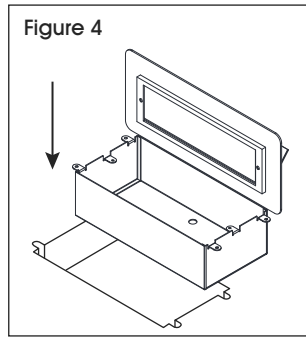

9. Secure power center to tabletop (4) using four M3.5 x 10 mm screws (F) packaged with power center. (See Figure 5)

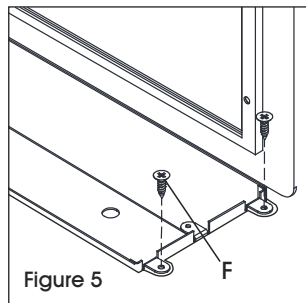

10. Attach pop up outlets to power center casing by turning screws clockwise. (See Figure 6)

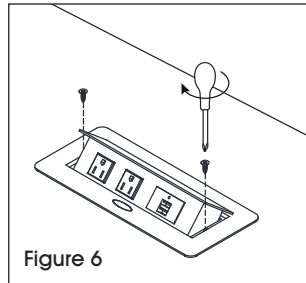

11. Stick adhesive-backed cable clips (G) under tabletop (4) to secure and route cables. (See Figure 7)

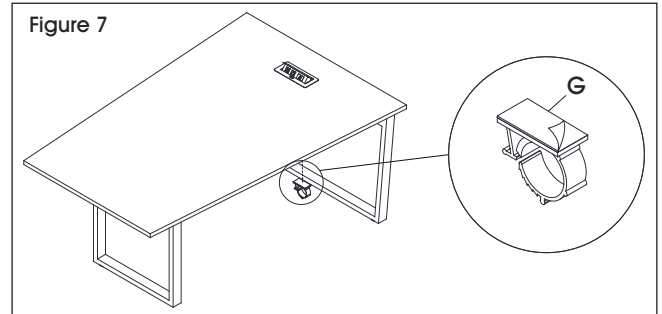

CONNECTING TWO TABLES (OPTIONAL)

1. Place wide legs of two tables together.
2. Align two flat brackets (E) with pre-drilled holes on underside of tables. (See Figure 8)
3. Secure each flat bracket (E) using six M6 x 15 mm bolts (B). (See Figures 8-9)

 **NOTE:** Tables do not need to be flipped over to connect together. Figure 8 is shown for reference only.

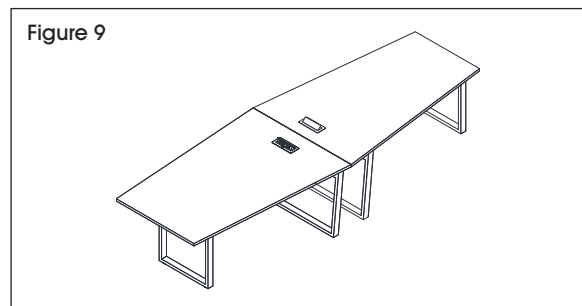
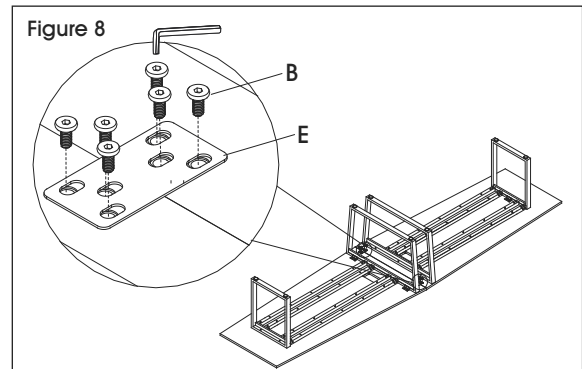

ULINE

1-800-295-5510

uline.com

ULINE H-8263

MESA PARA VIDEOCONFERENCIAS DE 96 x 48"

800-295-5510
uline.mx

HERRAMIENTAS NECESARIAS



Llave Allen (Incluida)

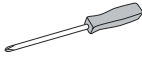

Desarmador de Cruz



Se recomienda Armar Entre Tres Personas

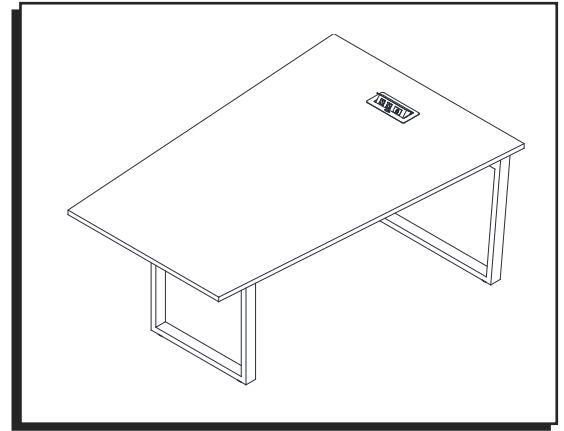

PARTES

A

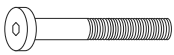

5 Pernos M6 x 45 mm

B

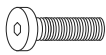

12 Pernos M6 x 15 mm

C

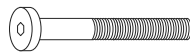

20 Pernos M6 x 60 mm

D



32 Pernos M6 x 12 mm

E

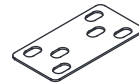

1 Soporte Plano

F



4 Tornillos M3.5 x 10 mm

G

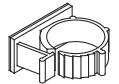

4 Clips con Respaldo Adhesivo para Cable

ENSAMBLE



NOTA: Verifique que todas las partes estén incluidas. Los cuatro tornillos M3.5 x 10 mm (F) vienen empacados con el multicontactos.



NOTA: La mesa también incluye un soporte plano y seis pernos adicionales M6 x 15 mm para la opción de conectar dos mesas.

1. Acomode el riel (1) sobre su soporte correspondiente en la pata angosta (2). Asegure usando cuatro pernos M6 x 12 mm (D). Repita para fijar los tres rieles restantes. (Vea Diagrama 1)
2. Fije todos los rieles (1) a la pata ancha (3) usando cuatro pernos M6 x 12 mm (D) por riel. (Vea Diagrama 1)



NOTA: No apriete por completo los pernos hasta que fije la cubierta.

Siga el patrón de orificios en el armazón como se muestra.



Diagrama 1

3. Coloque la cubierta (4) en el armazón ensamblado. Fije la cubierta (4) a la pata angosta (2) usando dos pernos M6 x 45 mm (A). Asegure la pata ancha (3) usando tres pernos M6 x 45 mm (A). (Vea Diagrama 2)
4. Fije la cubierta (4) a los soportes en las patas usando dos pernos M6 x 15 mm (B) por soporte. (Vea Diagrama 2)
5. Asegure la cubierta (4) a los rieles (1) usando cinco pernos M6 x 60 mm (C) por riel. (Vea Diagrama 2)

Diagrama 2

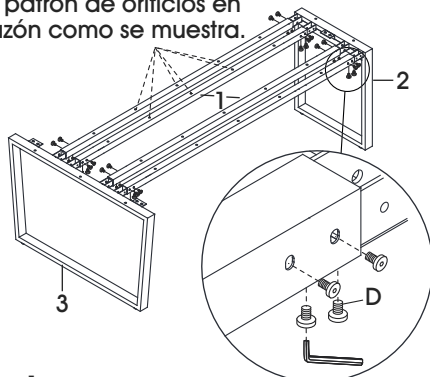
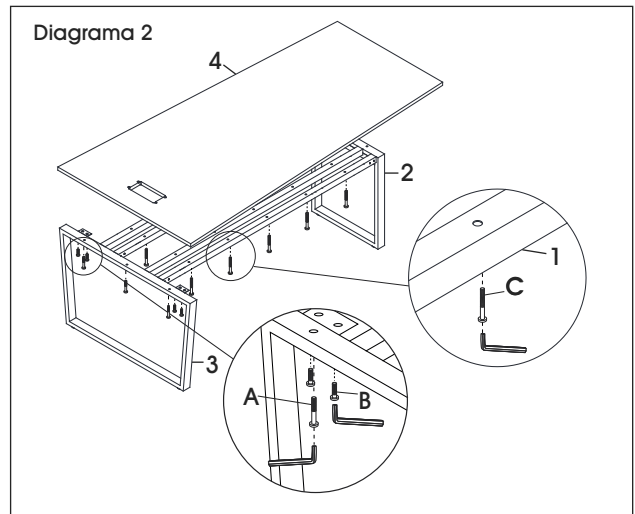

6. Apriete los pernos (D) instalados en los Pasos 1 y 2 con la llave Allen.

CONTINUACIÓN DEL ENSAMBLE

7. Retire el multicontactos abatible de la caja girando los tornillos en sentido contrario a las manecillas del reloj. (Vea Diagrama 3)

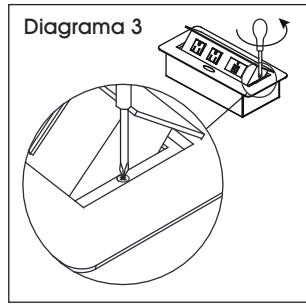

8. Inserte la caja del multicontactos en el orificio correspondiente de la cubierta (4). (Vea Diagrama 4)

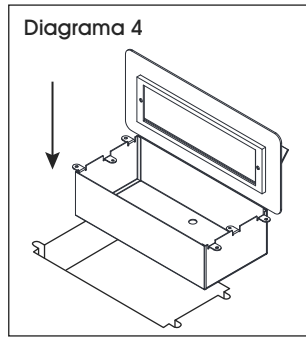

9. Asegure el multicontactos a la cubierta (4) usando cuatro tornillos M3.5 x 10 mm (F) empacados con el multicontactos. (Vea Diagrama 5)

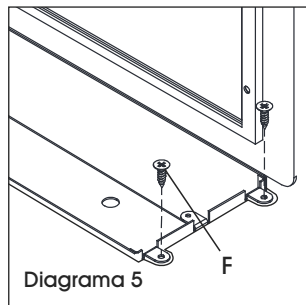

10. Fije el multicontactos abatible a la caja girando los tornillos en sentido de las manecillas del reloj. (Vea Diagrama 6)

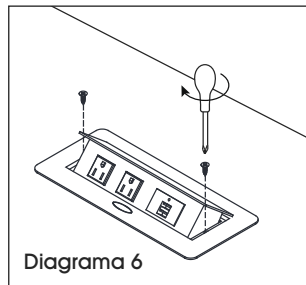

11. Pegue los clips con respaldo adhesivo (G) debajo de la cubierta (4) para asegurar y dirigir los cables. (Vea Diagrama 7)

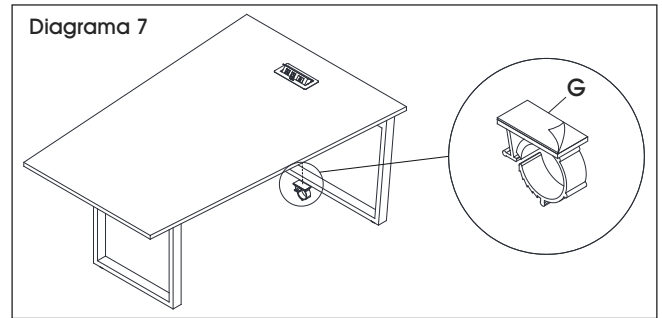

CONEXIÓN DE DOS MESAS (OPCIONAL)

1. Junte las patas anchas de las dos mesas.
2. Alinee dos soportes planos (E) con los orificios preperforados que están debajo de las mesas. (Vea Diagrama 8)
3. Asegure cada soporte plano (E) usando seis pernos M6 x 15 mm (B). (Vea Diagramas 8-9)

 **NOTA:** No se necesitan voltear las mesas al revés para conectarlas. El Diagrama 8 solo se muestra como referencia.

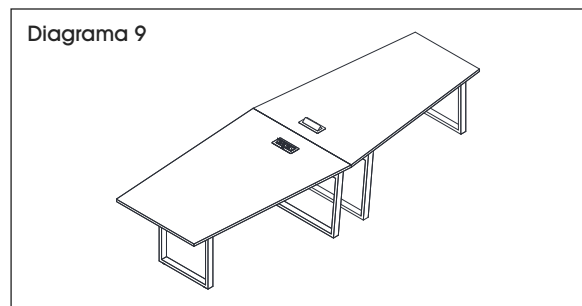
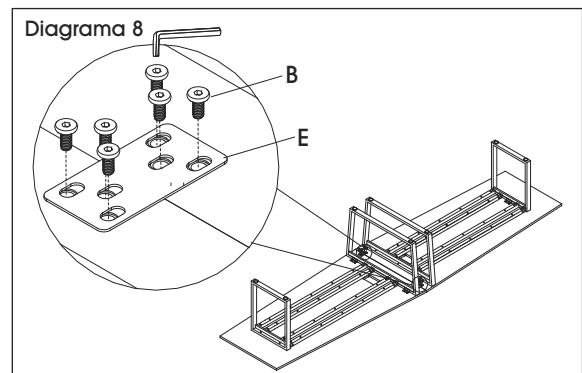

ULINE

800-295-5510

uline.mx

ULINE H-8263

TABLE DE CONFÉRENCE À MÉDIAS – 96 x 48 po

1-800-295-5510
uline.ca

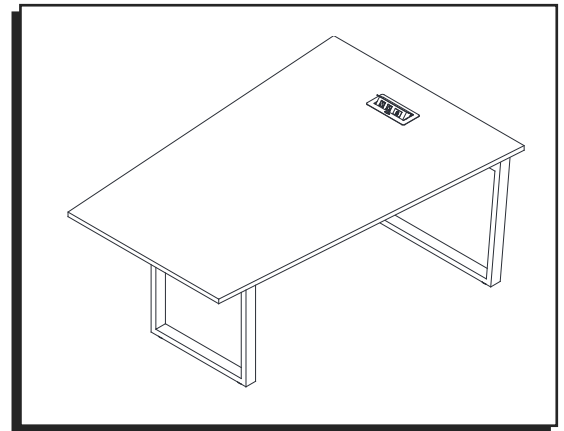

OUTILS REQUIS

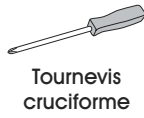

Montage à trois personnes recommandé

PIÈCES

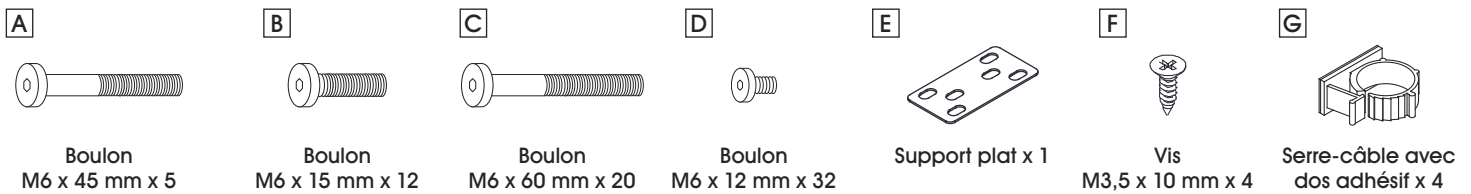

MONTAGE

REMARQUE : Vérifiez que toutes les pièces sont incluses. Les quatre vis M3,5 x 10 mm (F) sont livrées emballées avec le système d'alimentation.

REMARQUE : La table comprend aussi un support plat et six boulons M6 x 15 mm supplémentaires si vous optez de rattacher deux tables.

- Placez la barre de soutien (1) sur le support correspondant situé sur le pied étroit (2). Fixez le tout avec quatre boulons M6 x 12 mm (D). Répétez l'opération pour les trois autres barres de soutien. (Voir Figure 1)
- Fixez toutes les barres de soutien (1) au pied large (3) avec quatre boulons M6 x 12 mm (D) par barre. (Voir Figure 1)

REMARQUE : Ne serrez pas les boulons avant le montage complet de la surface de table.

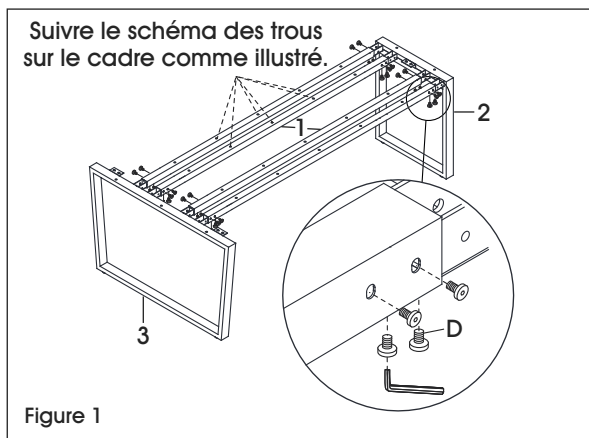

- Placez la surface de table (4) sur le cadre assemblé. Fixez la surface de table (4) au pied étroit (2) avec deux boulons M6 x 45 mm (A). Fixez le pied large (3) avec trois boulons M6 x 45 mm (A). (Voir Figure 2)
- Fixez la surface de table (4) aux supports des pieds avec deux boulons M6 x 15 mm (B) par support. (Voir Figure 2)
- Fixez la surface de table (4) aux barres de soutien (1) avec cinq boulons M6 x 60 mm (C) par barre. (Voir Figure 2)

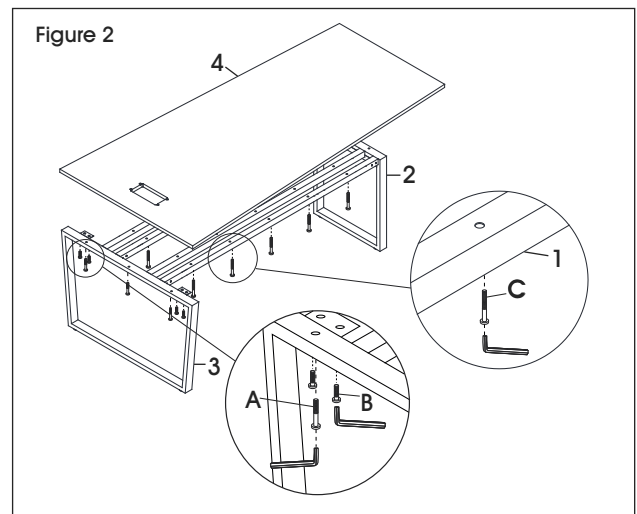

- Serrez avec une clé Allen les boulons (D) installés aux étapes 1 et 2.

MONTAGE SUITE

7. Retirez les prises rabattables du boîtier du système d'alimentation en dévissant les vis dans le sens antihoraire. (Voir Figure 3)

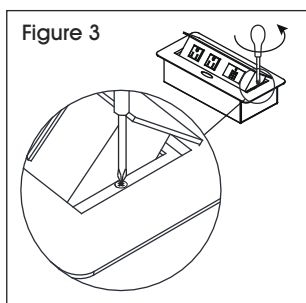

8. Insérez le boîtier du système d'alimentation dans le trou prévu à cet effet sur la surface de table (4). (Voir Figure 4)

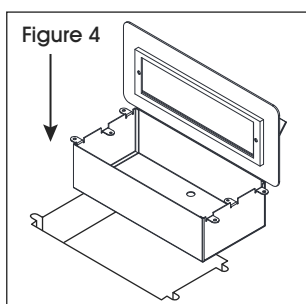

9. Fixez le système d'alimentation à la surface de table (4) avec les quatre vis M3,5 x 10 mm (F) livrées avec l'emballage. (Voir Figure 5)

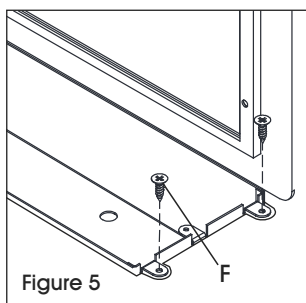

10. Fixez les prises rabattables au système d'alimentation en serrant les vis dans le sens horaire. (Voir Figure 6)

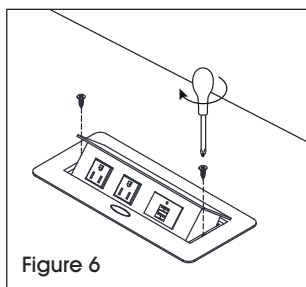

11. Collez les serre-câbles avec dos adhésif (G) sous la surface de table (4) pour acheminer et maintenir les câbles. (Voir Figure 7)

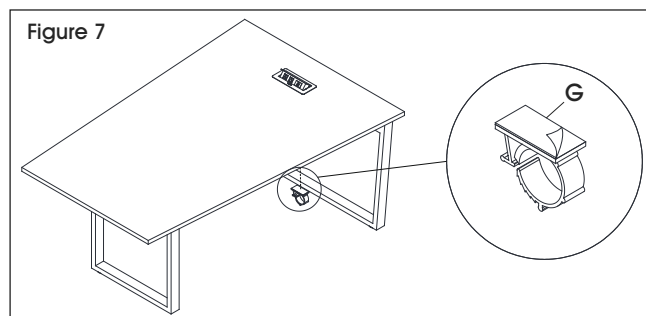

RATTACHER DEUX TABLES (OPTIONNEL)

1. Placez deux pieds larges côte à côte.
2. Alignez deux supports plats (E) sur les trous prépercés situés sous les tables. (Voir Figure 8)
3. Fixez chaque support plat (E) avec six boulons M6 x 15 mm (B). (Voir Figures 8 et 9)

 **REMARQUE :** Les tables n'ont pas besoin d'être retournées pour être rattachées ensemble. La figure 8 est présentée à titre indicatif uniquement.

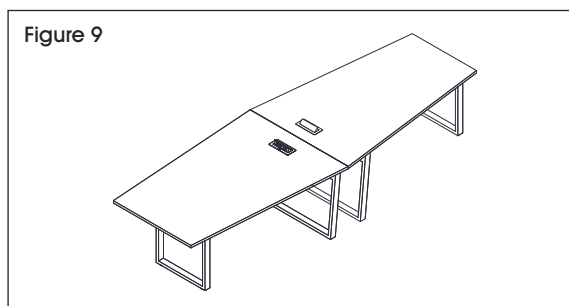
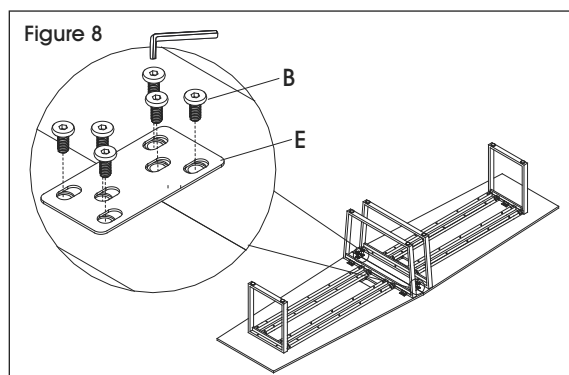

ULINE

1-800-295-5510
uline.ca